



# NOTICE D'EMPLOI

---

## Motoculteur

### KS650

---

Essence



Yvan Béal - 21, av. de l'Agriculture - B.P. 16  
Z.I. du Brézet - 63014 Clermont-Ferrand Cedex 2  
Tél : 04 73 91 93 51 - Télécopie : 04 73 90 23 11  
www.yvanbeal.fr - E-mail : info@yvanbeal.fr  
R.C.S. Clermont-Fd B 304 973 886 S.A.S. au capital de 612 000 €

1300-098-0120-2

**03-000157-050215**



## CONTENTS

ENGINE	( K F 6 4            f o r K S 6 5 0 )	PAGE
Fig. 1	ENGINE ..... Moteur	1
Fig. 2	AIR CLEANER ..... Filtre a air	6
Fig. 3	MAGNETO ..... Decanteur	7
Fig. 4	CARBURETOR ..... Carburateur	8
<b>CHASSIS</b>		
Fig. 5	BONNET AND FUEL TANK ..... Reservoir & capot	11
Fig. 6	FRAME AND FENDER ..... Longeron & garde-boue	15
Fig. 7	MAIN GEAR CASE ..... Boitier de reducteur	19
Fig. 8	TRANSMISSION GEAR ..... Reducteur	23
Fig. 9	SHIFTER ..... Fourchettes	27
Fig. 10	SUB TRANSMISSION ..... Boite de vitesses sub.	29
Fig. 11	TENSION AND BRAKE SYSTEM ..... Embrayage & frein	33
Fig. 12	HANDLE FRAME ..... Mancherons	39
Fig. 13	CONTROL LEVER ..... Commandes	45
Fig. 14	RECOIL STARTER ..... Lanceur	51
Fig. 15	WHEEL ..... Roues	53
Fig. 16	COUNTER CHAIN CASE ..... Chaine intermediaire	55

		PAGE
Fig. 17	ROTARY CHAIN CASE ..... Transmission de rotobineuse	57
Fig. 18	ROTARY FRAME ..... Enveloppe de rotobineuses	61
Fig. 19	ROTARY PIPE ..... Fraise	65
Fig. 20	REAR WHEEL ..... Roue de profondeur	67
Fig. 21	TOOLS ..... Outils	69
Fig. 22	ROTARY BELT DRIVE ..... Courroie intermediaire	73
Fig. 23	BACKPROOF DEVICE ..... Mechanisme de securite	75
Fig. 24	ROTARY CHAIN CASE ..... Transmission de rotobineuse	77
Fig. 25	ROTARY SHIFTER ..... Embrayage de rotobineuse	79
Fig. 26	ROTARY PIPE ..... Fraise	81
Fig. 27	ROTARY FRAME ..... Enveloppe de rotobineuses	83

M O T E U R - K F 64

( P O U R K S 650 )

\*\*\*\*

Fig. 1 ENGINE  
Moteur

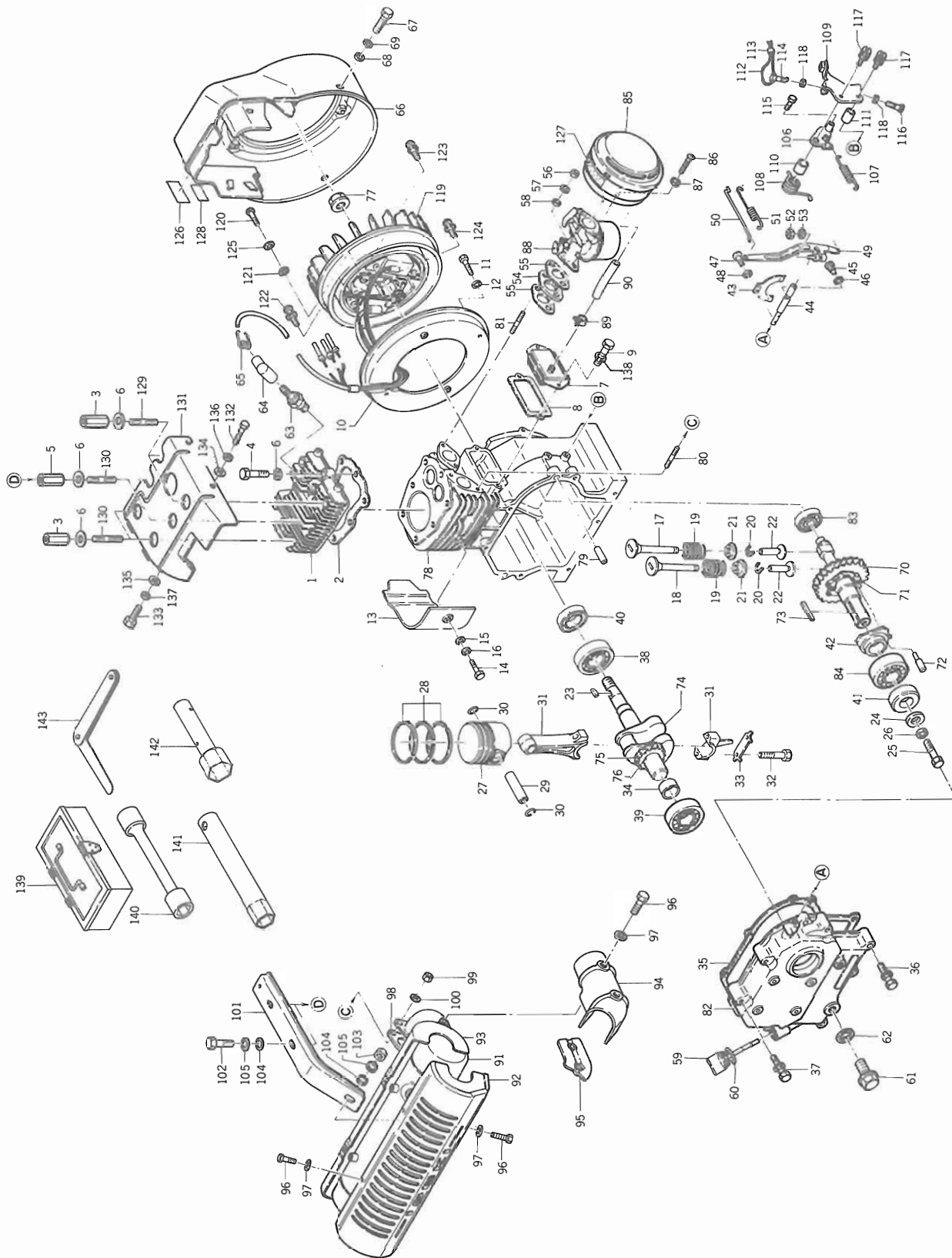

Ref No. Réf N°.	Parts No. Pièces N°.	Description Désignation	Model & Qty Modél & Quant	Remarks Remarques
1- 1	5164-701-1110-0	HEAD, CYLINDER Culasse	1	316470-1111-00
1- 2	5164-701-1210-0	GASKET, HEAD Joint	1	316470-1121-00
1- 3	5182-911-1830-0	NUT, LONG Ecrou	4	318291-1183-00
1- 4	5110-G10-45XX-X	BOLT Vis	1	110G 1045
1- 5	5164-911-1830-0	NUT, LONG Ecrou colonne	2	316491-1183-00
1- 6	5410-B10-00XX-X	WASHER Rondelle	7	410B 1000
1- 7	5164-701-2310-4	COVER, INSPECTION Porte de visite	1	316470-1231-04
1- 8	5164-701-2320-0	GASKET Joint	1	316470-1232-00
1- 9	5110-B06-12XX-X	BOLT Vis	2	110B 0612
1-10	5164-931-6120-1	CASE, SPIRAL Flasque de volant	1	316493-1612-01
1-11	5110-B06-12XX-X	BOLT Vis	4	110B 0612
1-12	5461-F06-00AX-X	WASHER, SPRING Rondelle frein	4	461F 0600A
1-13	5164-931-6320-1	COVER, CYLINDER Couvre cyl.	1	316493-1632-01
1-14	5110-B06-12XX-X	BOLT Vis	1	110B 0612
1-15	5410-B06-00XX-X	WASHER Rondelle	1	410B 0600
1-16	5461-F06-00AX-X	WASHER, SPRING Rondelle frein	1	461F 0600A
1-17	5164-702-1110-0	VALVE, INLET Soupape adm.	1	316470-2111-00
1-18	5164-702-1120-1	VALVE, EXHAUST Soupape ech.	1	316470-2112-01
1-19	5152-502-1130-0	SPRING, VALVE Ressort	2	315250-2113-00
1-20	5164-702-1150-0	COLLET Collet	2	316470-2115-00
1-21	5164-702-1160-0	SEAT, SPRING Cuvette	2	316470-2116-00
1-22	5164-702-2110-0	TAPPET Poussoir	2	316470-2211-00
1-23	5136-502-3710-0	KEY Clavette	1	313650-2371-00
1-24	5164-913-2740-0	WASHER Rondelle	1	316491-3274-00
1-25	5110-B08-25AX-X	BOLT Vis	1	110B 0825A
1-26	5461-F08-00XX-X	WASHER, SPRING Rondelle frein	1	461F 0800
1-27	5164-703-1110-2	PISTON Piston	1	316470-3111-02
1-28	5164-703-0100-0	PISTON RING SET Segmentation	1	316470-3010-00
1-29	5164-703-1210-0	PIN, PISTON Axe de piston	1	316470-3121-00
1-30	5164-703-1220-0	RING, SNAP Collet d'axe	2	316470-3122-00
1-31	5164-703-2400-0	CONNECTING ROD ASSY Bielle	1	316470-3240-00
1-32	5164-703-2450-0	BOLT, CONNECTING ROD Vis	2	316470-3245-00
1-33	5164-703-2480-0	PLATE, LOCK Rondelle	1	316470-3248-00
1-34	5164-703-2610-0	COLLAR Entretoise	1	316470-3261-00
1-35	5164-704-1240-0	GASKET Joint	1	316470-4124-00
1-36	5181-B08-43XX-X	BOLT Vis	5	181B 0843
1-37	5181-B08-40XX-X	BOLT Vis	2	181B 0840
1-38	5601-A63-06XX-X	BEARING, BALL Roulement	1	601A 6306

Ref No. Réf N°.	Parts No. Pièces N°.	Description Désignation	Model & Q'ty Modél & Quant	Remarks Remarques
1-39	5601-A62-06XX-0	BEARING, BALL Roulement	1	601A 6206
1-40	5146-704-2310-0	SEAL, OIL Bague d'étancheite	1	316470-4231-00
1-41	5152-504-2350-0	SEAL, OIL Bague d'étancheite	1	315250-4235-00
1-42	5164-705-1210-0	SLEEVE, GOVERNOR Manchon	1	316470-5121-00
1-43	5164-705-1220-0	TIP, GOVERNOR Doigt	1	316470-5122-00
1-44	5164-705-1230-0	SHAFT, GOVERNOR Axe	1	316470-5123-00
1-45	5162-905-1240-0	STOPPER Vis	1	316290-5124-00
1-46	5151-921-2330-0	GASKET Joint	1	315192-1233-00
1-47	5214-B04-06AX-0	SCREW Vis	2	214B 0406A
1-48	5461-F04-00XX-0	WASHER, SPRING Rondelle frein	2	461F 0400
1-49	5164-705-2110-0	ARM, GOVERNOR Bras	1	316470-5211-00
1-50	5135-505-2310-0	LINK, GOVERNOR Biellette	1	313550-5231-00
1-51	5135-505-2320-0	SPRING, LINK Ressort	1	313550-5232-00
1-52	5311-B06-00AX-X	NUT Ecrou	1	311B 0600
1-53	5461-F06-00AX-X	WASHER, SPRING Rondelle frein	1	461F 0600A
1-54	5151-926-1810-0	INSULATOR Isolant	1	315192-6181-00
1-55	5151-926-1840-0	GASKET Joint	2	315192-6184-00
1-56	5312-B06-00XX-X	NUT Ecrou	2	312B 0600
1-57	5461-F06-00AX-X	WASHER, SPRING Rondelle frein	2	461F 0600A
1-58	5410-B06-00XX-X	WASHER Rondelle	2	410B 0600
1-59	5164-707-4110-0	GAUGE, OIL Jauge	1	316470-7411-00
1-60	5151-927-4320-0	O-RING Joint torique	1	315192-7432-00
1-61	5182-947-4410-0	PLUG, DRAIN Bouchon	1	318294-7441-00
1-62	5312-017-2140-0	GASKET Joint	1	331201-7214-00
1-63	5123-018-4100-6	PLUG, SPARK Bougie	1	312301-8410-06
1-64	5172-708-418A-X	CAP, PLUG Capuchon	1	317270-8418A
1-65	5172-708-419A-X	SPRING Ressort	1	317270-8419A
1-66	5164-911-6110-7	CASE, SPIRAL Volute	1	316491-1611-07
1-67	5110-B06-12XX-X	BOLT Vis	4	110B 0612
1-68	5410-B06-00XX-X	WASHER Rondelle	4	410B 0600
1-69	5461-F06-00AX-X	WASHER, SPRING Rondelle frein	4	461F 0600A
1-70	5164-702-3100-2	CAM SHAFT ASSY A - C	1	316470-2310-02
1-71	5164-705-1100-0	GOVERNOR ASSY Regulateur	1	316470-5110-00
1-72	5135-015-1150-0	PIN, GUIDE Palpeur	1	313501-5115-00
1-73	5511-A07-35XX-X	KEY Clavette	1	511A 0735
1-74	5164-703-2100-1	CRANK SHAFT ASSY Vilebrequin	1	316470-3210-01
1-75	5164-703-2170-1	GEAR, CRANK GEAR Pignon	1	316470-3217-01
1-76	5132-522-3710-0	KEY, CRANK GEAR Clavette	1	313252-2371-00



Ref No. Réf N°.	Parts No. Pièces N°.	Description Désignation	Model & Q'ty Modél & Quant	Remarks Remarques	
1- 77	5132-523-4810-0	NUT Ecrou	1	313252-3481-00	
1- 78	5164-914-110B-X	CRANK CASE ASSY Carter	1	316491-4110B	
1- 79	5551-A08-16XX-X	·PIN, DOWEL Pion	2	551A 0816	
1- 80	5171-G08-18XX-X	·STUD Goujon	2	171G 0818	
1- 81	5171-G06-25XX-X	·STUD Goujon	2	171G 0625	
1- 82	5164-914-1210-4	SIDE BASE Joue de carter	1	316491-4121-04	
1- 83	5601-A62-02XX-X	BEARING, BALL Roulement	1	601A 6202	
1- 84	5601-A62-06XX-X	BEARING, BALL Roulement	1	601A 6206	
1- 85	5164-911-3100-0	AIR CLEANER ASSY Filtre a air	1	316491-1310-00	See Fig. 2 Voir Fig. 2
1- 86	5214-B05-10AX-X	SCREW Vis	2	214B 0510A	
1- 87	5461-F05-00AX-X	WASHER, SPRING Rondelle frein	2	461F 0500A	
1- 88	5164-916-1000-0	CARBURETOR ASSY Carburateur	1	316491-6100-00	See Fig. 4 Voir Fig. 4
1- 89	5136-791-5320-0	CLAMP Collier	1	313679-1532-00	
1- 90	5700-S71-000X-X	PIPE (L=96mm) Conduit	1	700S 71000	
1- 91	5164-801-4000-0	MUFFLER ASSY Silencieux	1	316480-1400-00	
1- 92	5164-801-4310-0	·COVER, MUFFLER Protecteur	1	316480-1431-00	
1- 93	5164-801-4320-0	·COVER, MUFFLER Protecteur	1	316480-1432-00	
1- 94	5164-801-4330-0	·COVER Protege pipe	1	316480-1433-00	
1- 95	5164-801-4340-0	·COVER Protege pipe	1	316480-1434-00	
1- 96	5110-B06-10XX-X	·BOLT Vis	8	110B 0610	
1- 97	5461-F06-00AX-X	·WASHER, SPRING Rondelle frein	8	461F 0600A	
1- 98	5164-701-4420-0	GASKET Joint	1	316470-1442-00	
1- 99	5311-R08-00AX-X	NUT Ecrou	2	311R 0800A	
1-100	5461-F08-00XX-X	WASHER, SPRING Rondelle frein	2	461F 0800	
1-101	5164-911-4450-0	STAY Bride	1	316491-1445-00	
1-102	5110-B10-20XX-X	BOLT Vis	2	110B 1020	
1-103	5311-B10-00XX-X	NUT Ecrou	1	311B 1000	
1-104	5411-B10-00XX-X	WASHER Rondelle	3	411B 1000	
1-105	5461-F10-00AX-X	WASHER, SPRING Rondelle frein	3	461F 1000A	
1-106	5164-915-3100-0	LEVER ASSY Lever	1	316491-5310-00	
1-107	5164-705-3140-0	SPRING, GOVERNOR Ressort	1	316470-5314-00	
1-108	5136-905-3170-0	SPRING Ressort	1	313690-5317-00	
1-109	5136-905-3310-6	PLATE, CONTROL Plaque	1	313690-5331-06	
1-110	5182-905-3320-0	COLLAR Coussinet	1	318290-5332-00	
1-111	5182-905-3330-0	COLLAR Coussinet	1	318290-5333-00	
1-112	5342-905-3510-0	WIRE Fil	1	334290-5351-00	
1-113	5322-015-3520-0	CLAMP Arretoir	1	332201-5352-00	
1-114	5136-905-3820-0	BOLT Vis	1	313690-5382-00	

Ref No. Réf N°.	Parts No. Pièces N°.	Description Désignation	Model & Q'ty Modél & Quant	Remarks Remarques
1-115	5110-B05-08AX-X	BOLT Vis	1	110B 0508A
1-116	5136-405-3820-0	BOLT Vis	1	313640-5382-00
1-117	5234-B06-28XX-X	SCREW Vis	2	234B 0628
1-118	5312-B06-00XX-X	NUT Ecrou	2	312B 0600
1-119	5164-918-1100-5	MAGNETO ASSY Volant magn.	1	316491-8110-05 See Fig. 3 Voir Fig. 3
1-120	5214-B04-10AX-X	SCREW Vis	1	214B 0410A
1-121	5410-B04-00XX-X	WASHER Rondelle	1	410B 0400
1-122	5180-B06-25XX-X	SCREW Vis	2	180B 0625
1-123	5180-B06-30XX-X	SCREW Vis	2	180B 0630
1-124	5229-B04-12AX-X	SCREW Vis	2	229B 0412A
1-125	5461-F04-00XX-X	WASHER, SPRING Rondelle frein	1	461F 0400
1-126	5164-910-8130-0	LABEL, HORSE POWER Etiquettes	1	316491-0813-00
1-127	5164-970-8270-0	LABEL, AIR CLEANER Etiquettes	1	316497-0827-00
1-128	5136-930-8510-0	LABEL, CAUTION Etiquettes	1	313693-0851-00
1-129	5164-911-1850-0	STUD Goujon	2	316491-1185-00
1-130	5172-G10-35XX-X	STUD Goujon	4	172G 1035
1-131	5164-911-6310-7	COVER, CYLINDER HEAD Couvre culasse	1	316491-1631-07
1-132	5110-B06-12XX-X	BOLT Vis	1	110B 0612
1-133	5110-B08-14XX-X	BOLT Vis	2	110B 0814
1-134	5410-B06-00XX-X	WASHER Rondelle	1	410B 0600
1-135	5410-B08-00XX-X	WASHER Rondelle	2	410B 0800
1-136	5461-F06-00AX-X	WASHER, SPRING Rondelle frein	1	461F 0600A
1-137	5461-F08-00XX-X	WASHER, SPRING Rondelle frein	2	461F 0800
1-138	5461-F06-00AX-X	WASHER, SPRING Rondelle frein	2	461F 0600A
ACCESSORY				
1-139	5164-910-9000-0	TOOL ASSY Outils	1	316491-0900-00
1-140	5182-900-9310-0	·WRENCH, SOCKET Cle tube	1	318290-0931-00
1-141	5131-220-9420-1	·WRENCH, PLUG Cle a boue	1	313122-0942-01
1-142	5184-010-9440-0	·WRENCH, SOCKET Cle tube	1	318401-0944-00
1-143	5112-200-9720-0	·GAUGE, THICKNESS Jauge d'épaisseur	1	311220-0972-00

Fig. 2 AIR CLEANER  
Filtre a air

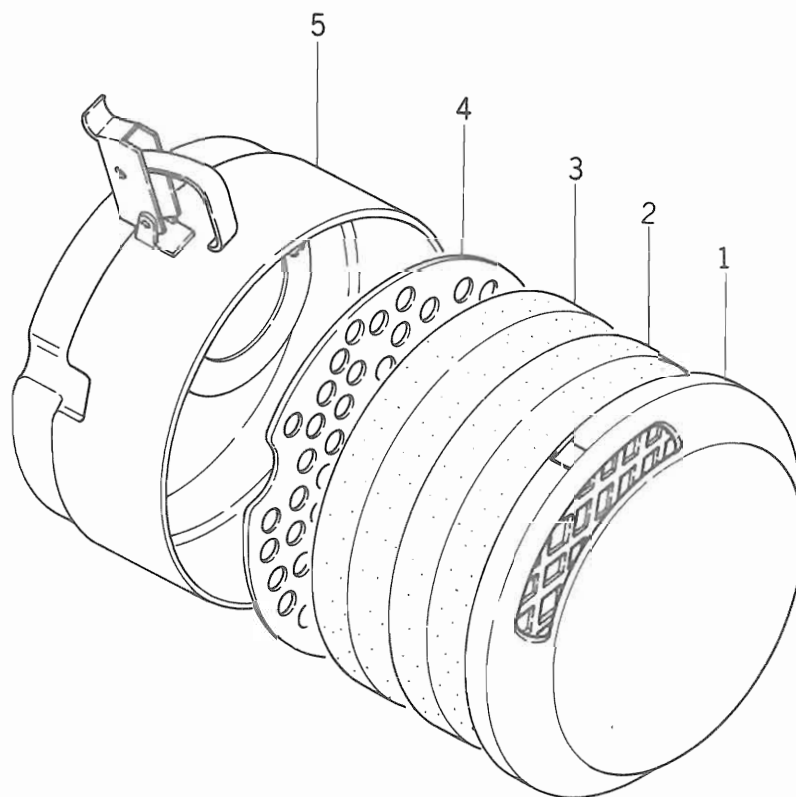

**No. 2**

Ref No. Réf N°.	Parts No. Pièces N°.	Description Désignation	Model & Q'ty Modél & Quant	Remarks Remarques
2- 0-1	5164-911-3100-0	AIR CLEANER ASSY Filtre a air	1	316491-1310-00
2- 1	5164-911-3130-0	·COVER Cloche	1	316491-1313-00
2- 2	5164-911-3120-0	·ELEMENT T=20 Cartouche	1	316491-1312-00
2- 3	5164-911-3140-0	·ELEMENT T=15 Cartouche	1	316491-1314-00
2- 4	5152-501-3270-0	·PLATE Grille	1	315250-1327-00
2- 5	5164-911-3110-0	·CASE Cuve	1	316491-1311-00

Fig. 3 MAGNETO  
Decanteur

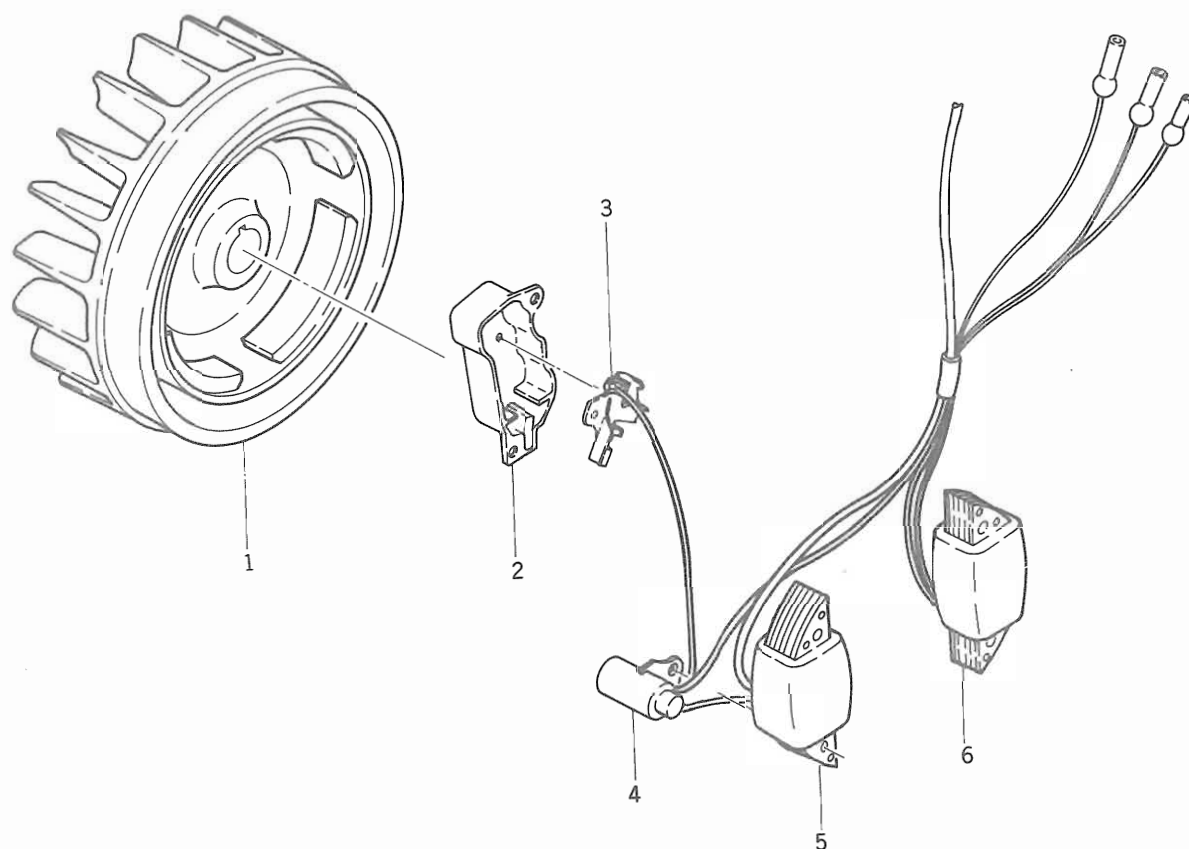

**No. 3**

Ref No. Réf N°.	Parts No. Pièces N°.	Description Désignation	Model & Q'ty Model & Quant	Remarks Remarques
3- 0- 1	5164-918-1100-5	MAGNETO ASSY Volant magnetique	1	316491-8110-05
3- 1	5164-908-1110-0	·FLYWHEEL Rotor	1	316490-8111-00
3- 2	5164-708-4390-0	·COVER Couvercle	1	316470-8439-00
3- 3	5136-018-4400-0	·BREAKER Rupteur	1	313601-8440-00
3- 4	5164-708-4360-0	·CONDENSER Condensateur	1	316470-8436-00
3- 5	5164-918-1230-2	·COIL, IGNITION Bobine d'allum.	1	316491-8123-02
3- 6	5153-728-1240-0	·COIL, LIGHTING Bobine d'eclairage	1	315372-8124-00

Fig. 4 CARBURETOR  
Carburateur

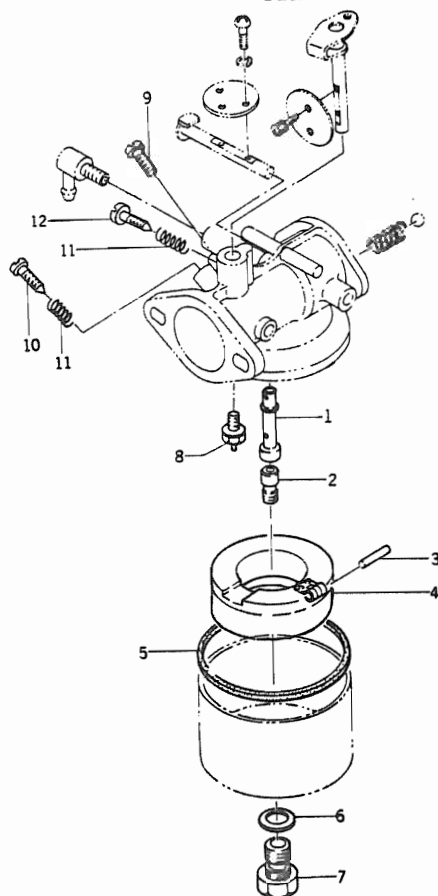

No. 4

Ref No. Réf N°.	Parts No. Pièces N°.	Description Désignation	Model & Q'ty Modél & Quant	Remarks Remarques
4- 0-1	5164-916-1000-0	CARBURETOR ASSY Carburateur	1	316491-6100-00
4- 1	5164-706-1290-0	·NOZZLE, MAIN (#13A) Emulseur	1	316470-6129-00
4- 2	5164-706-1320-0	·JET, MAIN (#87.5) Gicleur princ.	1	316470-6132-00
4- 3	5164-706-1270-0	·PIN, FLOAT Axe	1	316470-6127-00
4- 4	5164-706-1260-0	·FLOAT Flotteur	1	316470-6126-00
4- 5	5131-226-1280-0	·GASKET Joint	1	313122-6128-00
4- 6	5131-226-1800-0	·GASKET Joint	1	313122-6118-00
4- 7	5164-706-1430-0	·HOLDER, MAIN JET Vis	1	316470-6143-00
4- 8	5164-706-1200-0	·VALVE SEAT ASSY Clapet	1	316470-6120-00
4- 9	5136-506-1120-0	·JET, PILOT (#45) Gicleur ralenti	1	313650-6112-00
4-10	5136-506-1140-0	·SCREW, PILOT Vis ralenti	1	313650-6114-00
4-11	5131-226-1160-0	·SPRING Resort	2	313122-6116-00
4-12	5135-506-1151-0	·SCREW Vis	1	313550-6115-10

# CHASSIS

\*\*\*

Fig. 5 BONNET AND FUEL TANK  
Reservoir & capot

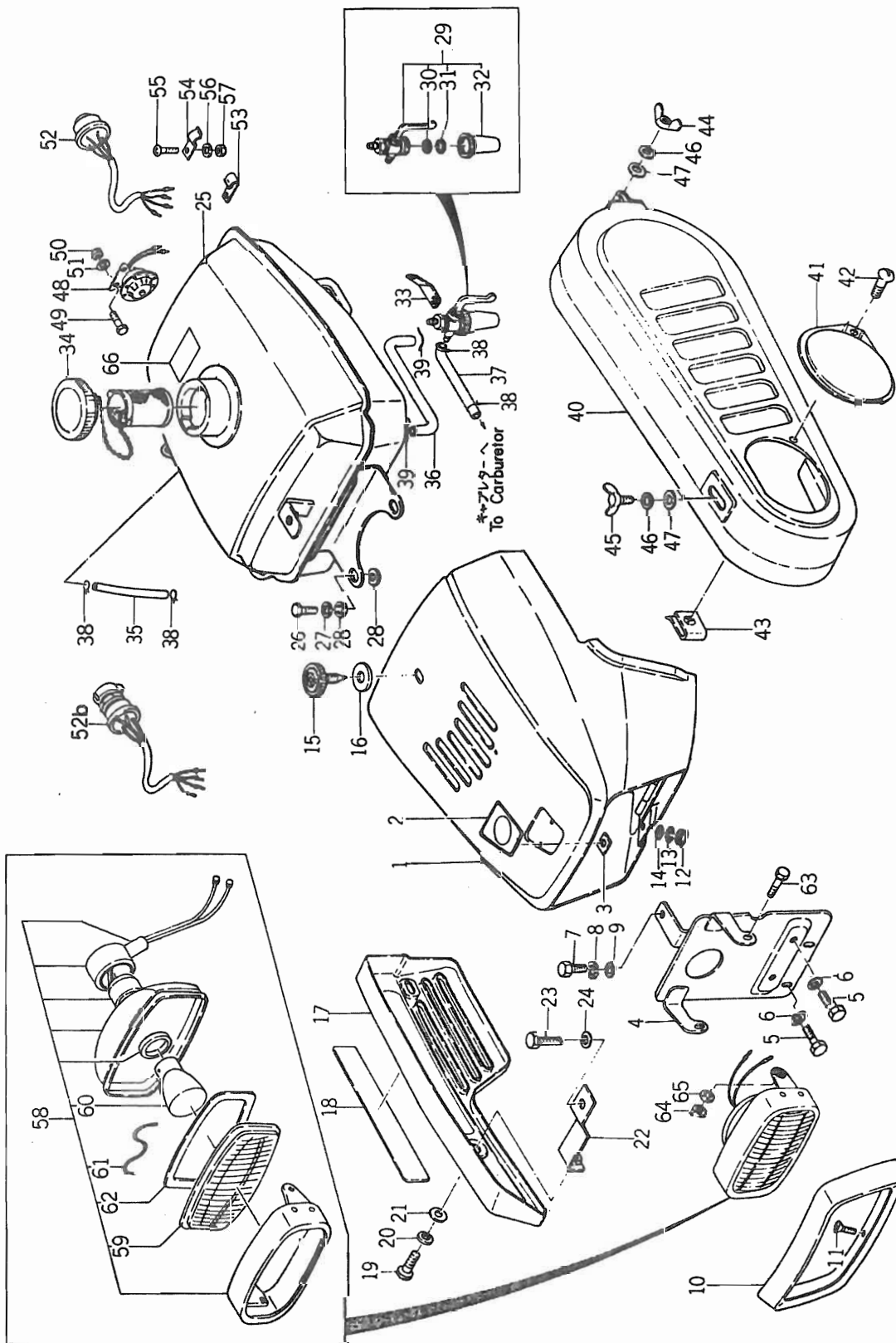

Ref No. Réf N°.	Parts No. Pièces N°.	Description Désignation	Model & Q'ty Modél & Quant			Remarks Remarques
			KS 650	KS 650D	KS 650E	
5- 1	1365-601-1000-1	BONNET Capot	1			
5- 2	1352-901-0040-0	MARK, F-GEAR Etiquette	1			
5- 3	1317-901-0050-0	NUT, SPEED Ecrou rapid	2			
5- 4	1365-601-2000-0	STAY, BONNET Calandre	1			
5- 5	V20126-080160	BOLT/M8×16 Vis	4			
5- 6	V40116-000800	WASHER, SP/M8 Rondelle frein	4			
5- 7	V20126-100160	BOLT/M10×16 Vis	1			
5- 8	V40116-001000	WASHER, SP/M10 Rondelle frein	1			
5- 9	V41316-000800	WASHER, PL/M8 Rondelle	1			
5-10	1352-601-0010-0	GRILLE, LIGHT Porte de phare	1			
5-11	V10415-600160	SCREW/M6×16 Vis	2			
5-12	V30026-000600	NUT/M6 Ecrou	2			
5-13	V40116-000600	WASHER, SP/M6 Rondelle frein	2			
5-14	V41316-000600	WASHER, PL/M6 Rondelle	2			
5-15	1352-601-0020-0	KNOB, SET Bouton de capot	1			
5-16	1352-601-0030-0	SUPPORT Rondelle d'arrêt	1			
5-17	1365-601-0010-0	COVER, SIDE Capot lateral	1			
5-18	1365-902-0010-0	MARK, SIDE Etiquette	1			
5-19	V11115-600120	SCREW/M6×12 Vis	2			
5-20	V40116-000600	WASHER, SP/M6 Rondelle frein	2			
5-21	V41115-000600	WASHER, PL/M6 Rondelle	2			
5-22	1365-601-3000-0	STAY Support capot	1			
5-23	V20126-080160	BOLT/M8×16 Vis	1			
5-24	V40116-000800	WASHER, SP/M8 Rondelle frein	1			
5-25	1365-606-1000-1	TANK, FUEL Reservoir	1			
5-26	V20126-100200	BOLT/M10×20 Vis	2			
5-27	V40116-001000	WASHER, SP/M10 Rondelle frein	2			
5-28	V41326-001000	WASHER, PL/M10 Rondelle	4			
5-29	1343-600-0510-0	STRAINER ASSY Robinet decanteur	1			
5-30	1337-606-0130-0	·STRAINER Filtre	1			
5-31	1337-606-0140-0	·PACKING, BOWL Joint	1			
5-32	1337-606-0150-0	·BOWL Bol	1			
5-33	1365-606-0011-0	STAY, STRAINER Support	1			
5-34	1338-606-4000-0	CAP, TANK Bouchon de reservoir	1			No. 1-9270
5-34a	1352-600-0531-0	CAP, TANK Bouchon de reservoir	1			No. 9271-
5-35	V73505-080800	PIPE, A/VINYL Conduit	1			For gauge Pour jaugl
5-36	1365-606-0030-0	PIPE, FUEL/200 Conduit	1			Tank to strainer
5-37	1365-606-0040-0	PIPE, FUEL/170 Conduit	1			Strainer to carburetor





Ref No. Réf N°.	Parts No. Pièces N°.	Description Désignation	Model & Q'ty Modél & Quant			Remarks Remarques	
			KS 650	KS 650D	KS 650E		
5-38	1317-606-0100-0	RING, SNAP PIPE Collet d'axe	4				
5-39	V59013-090900	WIRE/0.9×90 Fil	2				
5-40	1365-611-1000-1	COVER, BELT Carter de courroies	1			No. 1-14971	
5-41	1365-611-0010-0	CAP, COVER Carter de courroies	1				
5-42	V10016-600100	SCREW/M6×10 Vis	1				
5-43	1365-611-0020-0	NUT, SPEED/M6 Ecroû rapide	1				
5-44	V37016-000800	NUT, WING/M8 Ecroû a oreilles	1				
5-45	V27016-080150	BOLT, WING/M8×15 Vis a oreilles	1				
5-46	V40116-000800	WASHER, SP/M8 Rondelle frein	2				
5-47	V41316-000800	WASHER, PL/M8 Rondelle	2				
5-48	1317-621-0011-0	HORN UNIT Avertisseur	1				No. 1-3240
5-49	V20026-060120	BOLT/M6×12 Vis	2				No. 1-3240
5-50	V30026-000600	NUT/M6 Ecroû	2				
5-51	V40116-000600	WASHER, SP/M6 Rondelle frein	2				
5-52	1365-600-0510-0	SWITCH, MAIN ASSY Contacteur	1			No. 1-3240	
5-52a	1365-600-0511-0	SWITCH, MAIN ASSY Contacteur	1			No. 3241-6470	
5-52b	1365-600-0512-0	SWITCH, MAIN ASSY Contacteur	1			No. 6471-	
5-53	1317-621-0020-0	CLIP, LEAD WIRE Agrafe	3				
5-54	1352-621-0010-0	CLAMP Agrafe	1				
5-55	V11116-600120	SCREW/M6×12 Vis	1				
5-56	V40116-000600	WASHER, SP/M6 Rondelle frein	1				
5-57	V30026-000600	NUT/M6 Ecroû	1				
5-58	1324-600-0520-0	LAMP, HEAD Phare	1				
5-59	1317-621-0090-0	·LENS, HEAD LAMP Glace	1				
5-60	1306-621-0010-0	·BULB/6V-15/15W Ampoule	1				
5-61	1317-621-0110-0	·SPRING, CLAMP Ressort	4				
5-62	1317-621-0120-0	·PACKING, LENS Joint	1				
5-63	V20026-060160	BOLT/M6×16 Vis	2				
5-64	V30026-000600	NUT/M6 Ecroû	2				
5-65	V40116-000600	WASHER, SP/M6 Rondelle frein	2				
5-66	2706-701-0140-0	MARK Etiquette	1			No. 12771-	

Fig. 6 FRAME AND FENDER  
Longeron & garde-boue

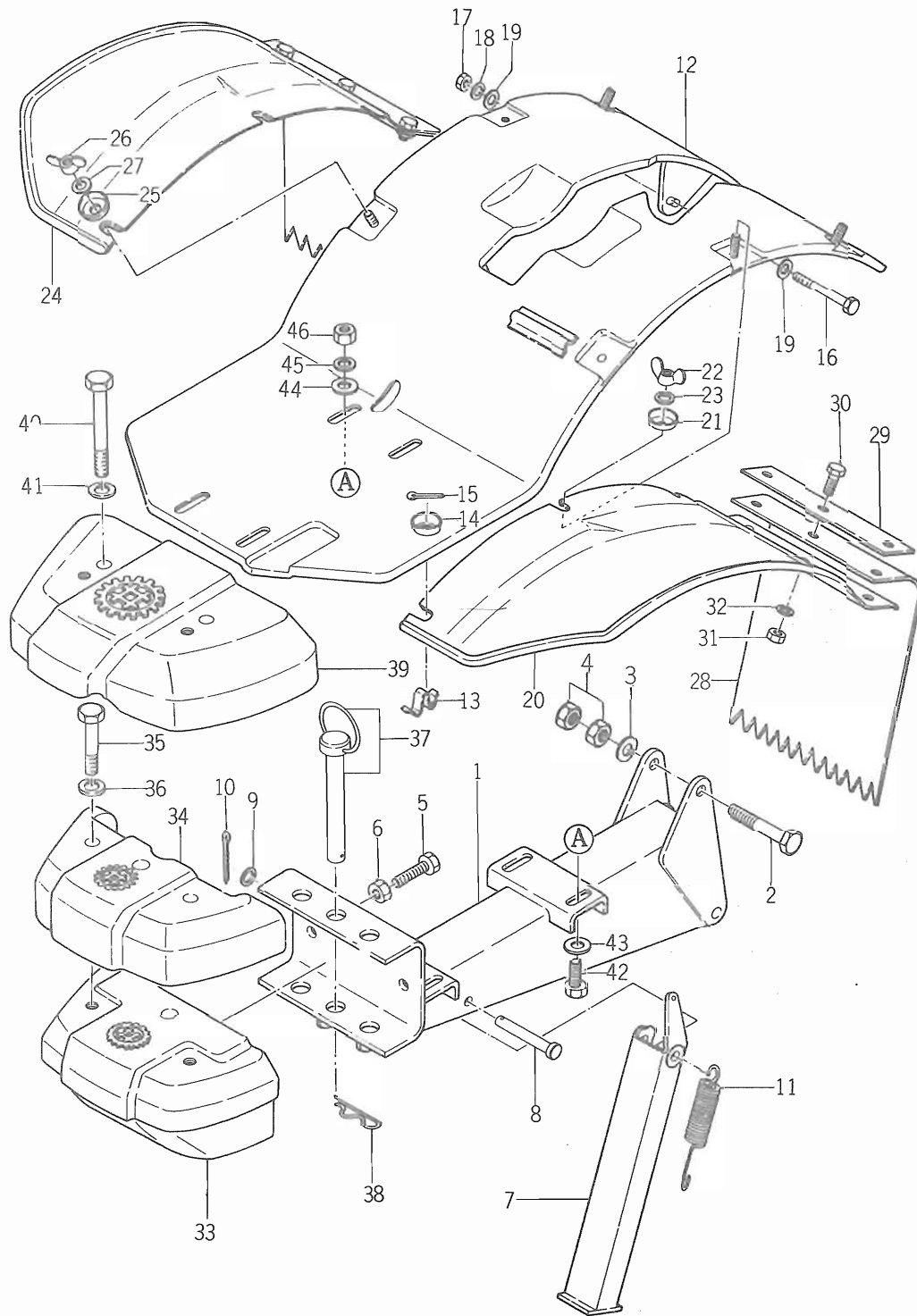
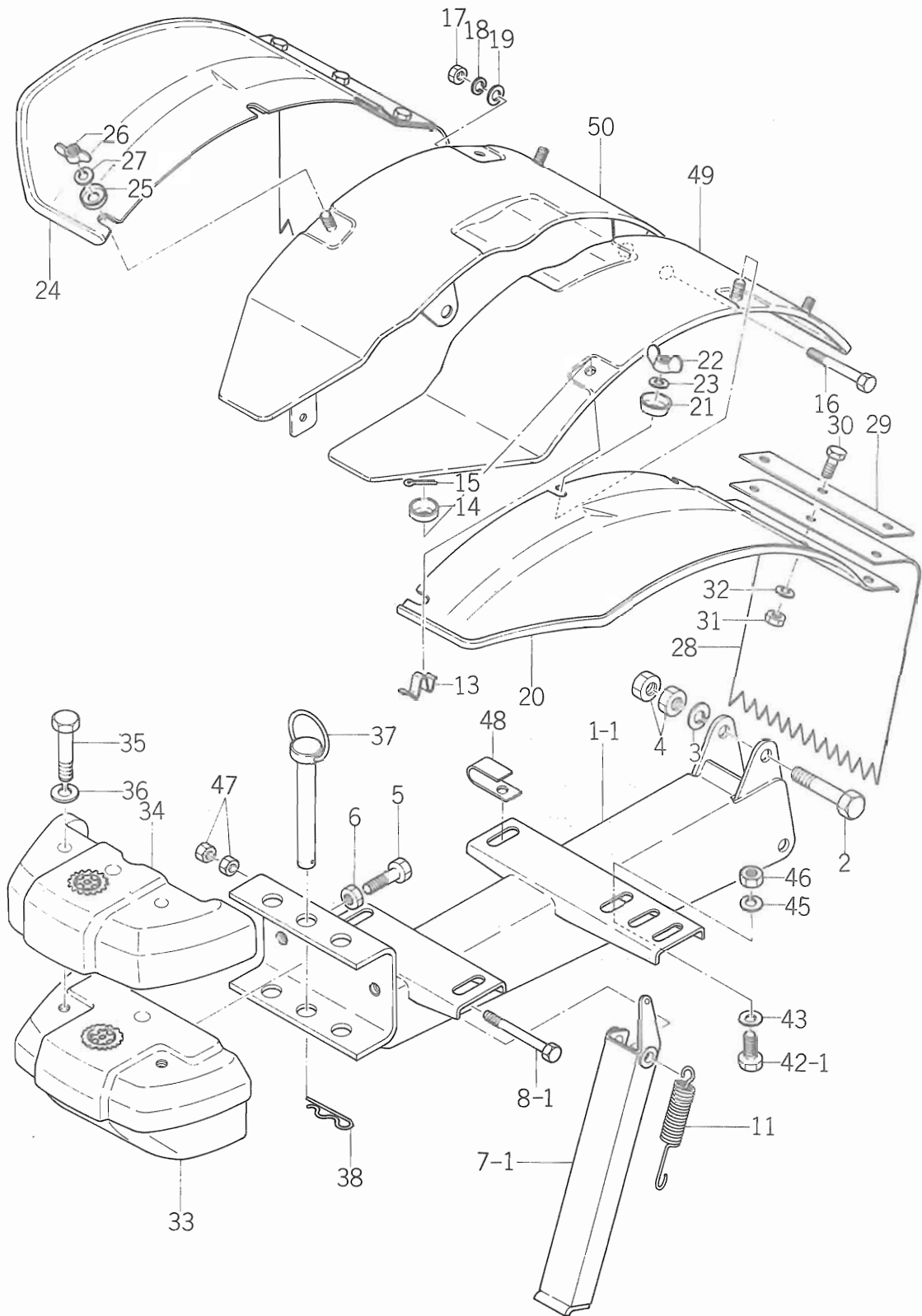

Fig. 6 FRAME AND FENDER  
Longeron & garde-boue



# No. 6

Ref No. Réf N°.	Parts No. Pièces N°.	Description Désignation	Model & Qty Modél & Quant			Remarks Remarques
			KS 650	KS 650D	KS 650E	
6- 1	1365-101-1000-0	FRAME, F. Longeron	1			
6- 1-1	1368-101-1000-0	FRAME, F. Longeron		1	1	
6- 2	V20126-120850	BOLT/M12×85 Vis	2	2	2	
6- 3	V40116-001200	WASHER, SP/M12 Rondelle frein	2	2	2	
6- 4	V30226-001200	NUT/M12 Ecrou	4	4	4	
6- 5	W20126-100350	BOLT/M10×35 S=35 Vis	2	2	2	
6- 6	V30026-001000	NUT/M10 Ecrou	2	2	2	
6- 7	1352-106-1000-2	STAND Bequille	1			
6- 7-1	1368-106-1000-0	STAND Bequille		1	1	
6- 8	1352-106-0010-0	PIN/10×59 Axe de bequille	1			
6- 8-1	V20126-100800	BOLT/M10×80 Vis		1	1	
6- 9	V41316-001000	WASHER, PL/M10 Rondelle	1			
6-10	V50015-250200	PIN, SPLIT/2.5×20 Goupille fendue	1			
6-11	1352-106-0020-0	SPRING, STAND Resort	1	1	1	
6-12	1365-616-1000-1	FENDER Garde-boue	1			No. 1-15800
6-12a	1365-616-1001-1	FENDER Garde-boue	1			No. 15801-
6-13	1352-616-0010-0	SPRING, PLATE Clip	2	2	2	
6-14	1352-616-0020-0	WASHER, CONE Rondelle	2	2	2	
6-15	V50015-300150	PIN, SPLIT/3×15 Goupille fendue	2	2	2	
6-16	V20126-080800	BOLT/M8×80 Vis	1	2	2	
6-17	V30026-000800	NUT/M8 Ecrou	1	2	2	
6-18	V40116-000800	WASHER, SP/M8 Rondelle frein	1	2	2	
6-19	V41316-000800	WASHER, PL/M8 Rondelle	2	2	2	
6-20	1365-616-2000-1	FENDER, SUB LH Garde-boue aux G.	1	1	1	
6-21	1352-616-0020-0	WASHER, CONE Rondelle	2	2	2	
6-22	V37116-000800	NUT, WING/M8 Ecrou a oreilles	2	2	2	
6-23	V40116-000800	WASHER, SP/M8 Rondelle frein	2	2	2	
6-24	1365-616-3000-1	FENDER, SUB RH Garde-boue aux D.	1	1	1	
6-25	1352-616-0020-0	WASHER, CONE Rondelle	2	2	2	
6-26	V37116-000800	NUT, WING/M8 Ecrou a oreilles	2	2	2	
6-27	V40116-000800	WASHER, SP/M8 Rondelle frein	2	2	2	
6-28	1352-616-0030-0	GUARD, MUD Bavette	2	2	2	
6-29	1352-616-0040-0	PLATE, SET Barrette	2	2	2	
6-30	V20026-060120	BOLT/M6×12 Vis	6	6	6	
6-31	V30026-000600	NUT/M6 Ecrou	6	6	6	
6-32	V40116-000600	WASHER, SP/M6 Rondelle frein	6	6	6	
6-33	1352-931-0010-0	WEIGHT, F·A Contrepoids	1	1	1	} DE, DHE ..... ★ E, EE, EHE ... ★
6-34	1352-931-0020-0	WEIGHT, F·B Contrepoids	1	1	1	

Ref No. Réf N°.	Parts No. Pièces N°.	Description Désignation	Model & Q'ty Modél & Quant			Remarks Remarques
			KS 650	KS 650D	KS 650E	
6-35	V20126-120600	BOLT/M12×60 Vis	2	2	2	} DE, DHE ..... ★ E, EE, EHE ... ★
6-36	V40116-001200	WASHER, SP Rondelle frein	2	2	2	
6-37	1301-100-9010-0	PIN, KING ASSY Broche	1	1	1	
6-38	1305-931-0030-0	PIN, HAIR Attache beta	1	1	1	
6-39	1352-931-0030-0	WEIGHT, F·C Contrepoids	1			★
6-40	V20126-120950	BOLT/M12×95 Vis	2			★
6-41	V40116-001200	WASHER, SP/M12 Rondelle frein	2			★
6-42	V20126-100450	BOLT/M10×45 Vis	4			
6-42-1	V20126-100350	BOLT/M10×35 Vis		4	4	
6-43	1365-121-0050-0	WASHER/10×20×2 Rondelle	4	4	4	
6-44	V41316-001000	WASHER, PL/M10 Rondelle	4			
6-45	V40116-001000	WASHER, SP/M10 Rondelle frein	4	4	4	
6-46	V30026-001000	NUT/M10 Erou	4	4	4	
6-47	V30226-001000	NUT/M10 Erou		2	2	
6-48	1404-621-0280-0	CLAMP, WIRE HARNESS C Attache		1	1	ENo. 1-14970
6-48a	1317-621-0020-0	CLIP, LEAD WIRE Agrafe			1	ENo. 14971 -
6-49	1368-616-1001-1	FENDER LH Garde boue		1	1	
6-50	1368-616-2001-1	FENDER RH Garde boue		1	1	

Fig. 7

# MAIN GEAR CASE

Boitier de reducteur

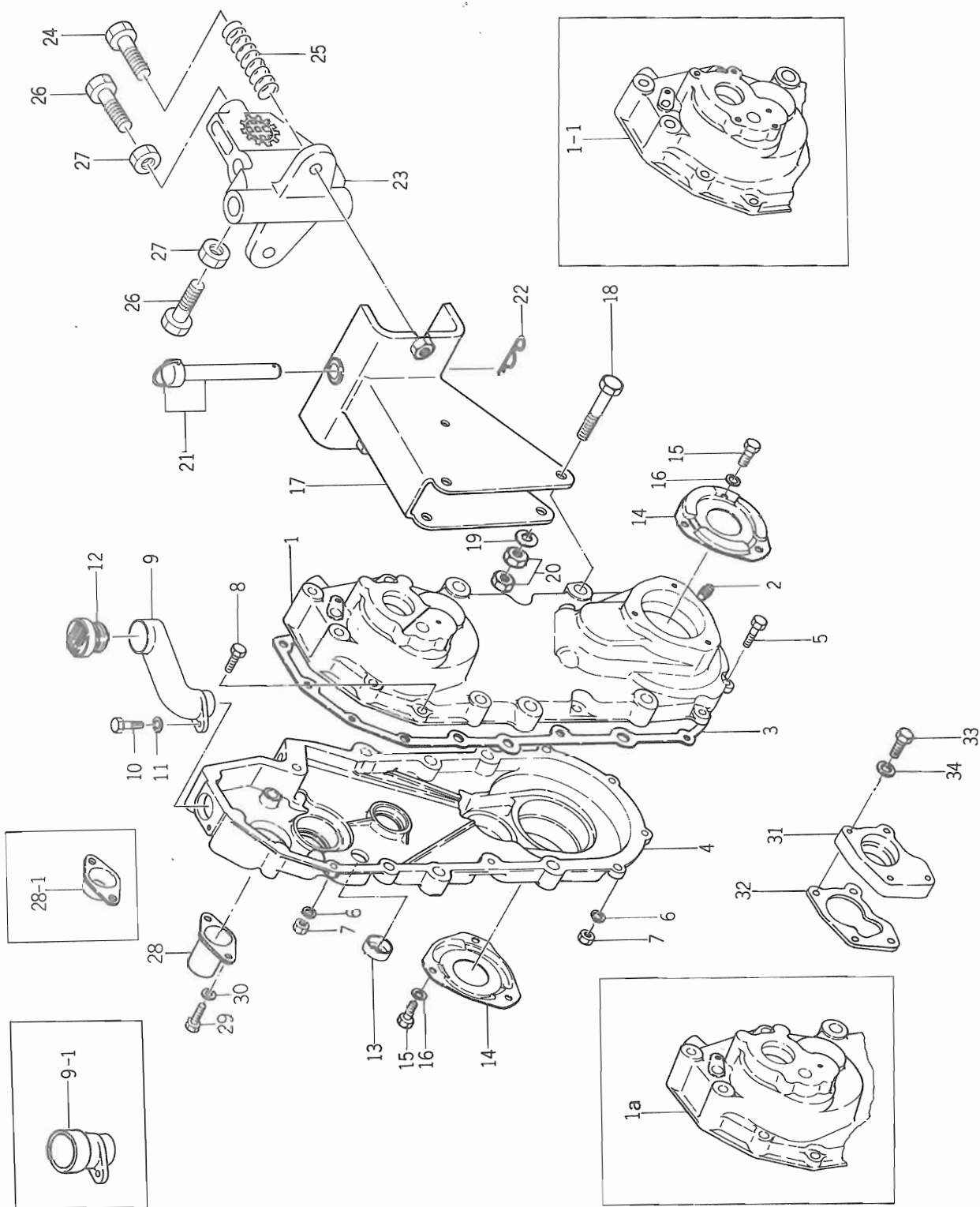

Ref No. Réf N°.	Parts No. Pièces N°.	Description Désignation	Model & Q'ty Modél & Quant			Remarks Remarques
			KS 650	KS 650D	KS 650E	
7- 1	1365-216-0010-0	CASE, MAIN GEAR LH Coquille G.	1		1	{ No. 1-3200 ENo. 1-7370
7- 1a	1365-216-0011-0	CASE, MAIN GEAR LH Coquille G.	1		1	{ No. 3201-15800 ENo. 7371- 51. 10. 1
7- 1b	1365-216-0012-0	CASE, MAIN GEAR LH Coquille G.	1			No. 15801-
7- 1-1	1371-216-0010-0	CASE, MAIN GEAR LH Coquille G.		1		For KS650-D DNo. 1-103900
7- 1-1a	1371-216-0011-0	CASE, MAIN GEAR LH Coquille G.		1	1	DNo. 103901- E51. 10. 1
7- 2	V78130-000060	PLUG / PT3/8 Bouchon	1	1	1	
7- 3	1352-216-0020-0	PACKING, GEAR CASE Joint	1	1	1	{ No. 1-15800 DNo. 1-103900 E51. 10. 1
7- 3a	1365-216-0050-0	PACKING, GEAR CASE Joint	1	1	1	{ No. 15801- DNo. 103901- E51. 10. 1
7- 4	1365-216-0020-0	CASE, MAIN GEAR RH Coquille D.	1		1	{ No. 1-3200 ENo. 1-7370
7- 4a	1365-216-0021-0	CASE, MAIN GEAR RH Coquille D.	1	1	1	{ No. 3201-15800 DNo. 1-103900 ENo. 7371- 51. 10. 1
7- 4b	1365-216-0022-0	CASE, MAIN GEAR RH Coquille D.	1	1	1	{ No. 15801- DNo. 103901- E51. 10. 1
7- 5	V20126-080250	BOLT/M8×25 Vis	6	6	6	
7- 6	V40116-000800	WASHER, SP/M8 Rondelle frein	7	7	7	
7- 7	V30026-000800	NUT/M8 Ecrou	7	7	7	
7- 8	V20126-080350	BOLT/M8×35 Vis	1	1	1	
7- 9	1352-216-0040-1	PIPE, OIL Goulot	1			
7- 9-1	1368-216-0010-0	PIPE, OIL Goulot		1	1	
7-10	V20026-060160	BOLT/M6×16 Vis	1	1	1	
7-11	V40116-000600	WASHER, SP/M6 Rondelle frein	1	1	1	
7-12	7951-103-1010-0	CAP, OIL/30 Bouchon	1		1	{ No. 1-4540 ENo. 1-4540
7-12a	7954-205-1010-0	CAP, OIL/30 Bouchon	1	1	1	{ No. 4541- DNo. 1- ENo. 4541-
7-13	1352-216-0050-0	LEVEL, OIL Mouchard	1	1	1	
7-14	1365-216-0030-0	METAL, WHEEL Flasque	2	2	2	
7-15	V20026-060120	BOLT/M6×12 Vis	6	6	6	
7-16	V40116-000600	WASHER, SP/M6 Rondelle frein	6	6	6	
7-17	1365-930-1000-0	HITCH, R. Attelage AR	1	1	1	
7-18	V20146-120750	BOLT/M12×75 Vis	2	2	2	
7-19	V40116-001200	WASHER, SP/M12 Rondelle frein	2	2	2	
7-20	V30226-001200	NUT/M12 Ecrou	4	4	4	GE, GHE, R
7-21	1301-100-9010-0	PIN, KING ASSY Broche	1	1	1	
7-22	1305-931-0030-0	PIN, HAIR Attache beta	1	1	1	
7- 0-1	8057-006-0000-0	HITCH, CULTI ASSY Attache culti ensemble	1	1	1	{ GE, GHE, R ... ★ 650D ... ★ E ..... ★
7-23	8057-006-0010-0	·HITCH, CULTI Attache culti	1	1	1	
7-24	8057-006-0020-0	·BOLT Vis	2	2	2	GE, GHE R .....★ 650D .....★ E .....★
7-25	8057-006-0030-0	·SPRING, LOCK Amortisseur	2	2	2	
7-26	V20126-120400	·BOLT/M12×40 S=35 Vis	2	2	2	
7-27	V30226-001200	·NUT/M12 Ecrou	2	2	2	
7-28	1365-216-0040-0	CAP, SHAFT/30×50 Embout	1	1	1	{ No. 8971- DNo. 1- ENo. 7371-

Fig. 7

MAIN GEAR CASE  
Boitier de reducteur

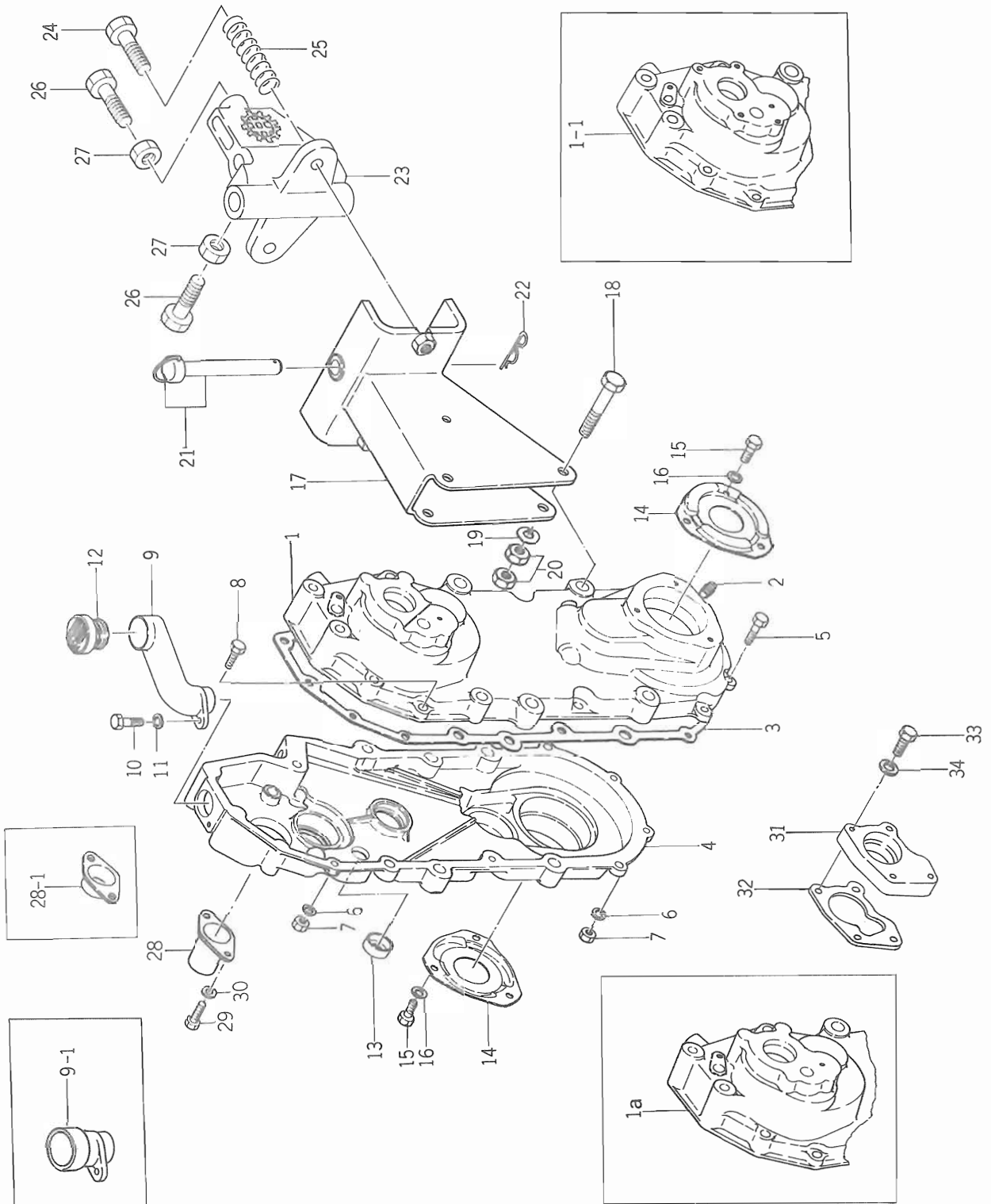



Ref No. Réf N°	Parts No. Pièces N°	Description Désignation	Model & Q'ty Modél & Quant			Remarks Remarques
			K S 6 5 0	K S 6 5 0 D	K S 6 5 0 E	
7-28-1	1365-701-0050-0	COVER, SHAFT Embout	1	1		No. 14971-
7-29	V20026-060100	BOLT/M6×10 Vis	2	2	2	} No. 8971- DNo. 1- ENo. 7371-
7-30	V40116-000600	WASHER, SP/M6 Rondelle frein	2	2	2	
7-31	1368-216-0020-0	METAL, MAIN SHAFT Flasque			1	} No. 15801-
7-32	1371-211-0021-0	PACKING, CASE Joint			1	
7-33	V20126-080250	BOLT/M8×25 Vis			4	
7-34	V40116-000800	WASHER, SP/M8 Rondelle frein			4	

Fig. 8 TRANSMISSION GEAR  
Reducteur

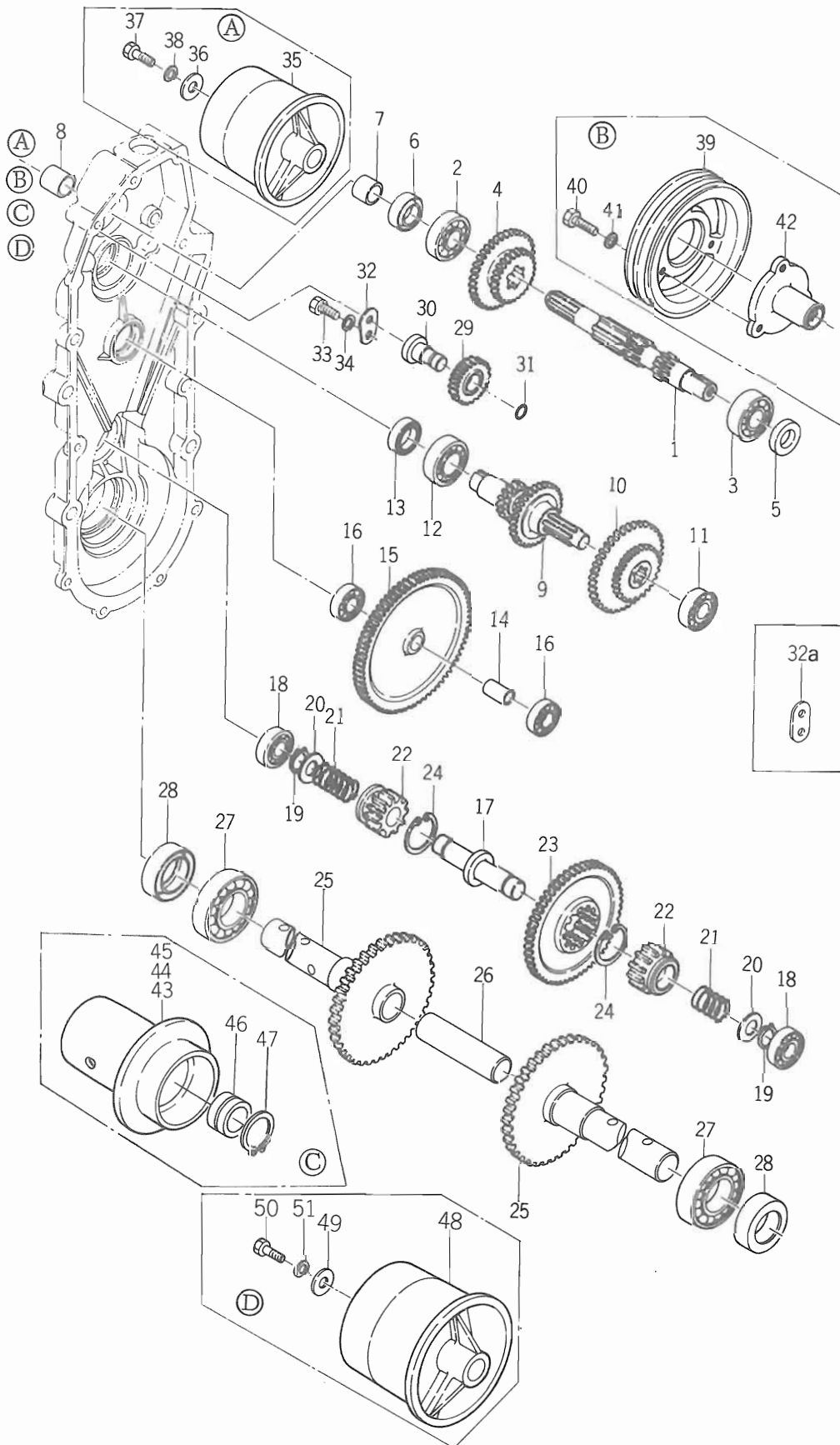

Ref No. Réf N°.	Parts No. Pièces N°.	Description Désignation	Model & Q'ty Modél & Quant			Remarks Remarques
			K S 6 5 0	K S 6 5 0 D	K S 6 5 0 E	
8- 1	1352-217-0010-0	SHAFT, MAIN Arbre primaire	1	1	1	
8- 2	V60011-063040	BEARING, RB/6304 Roulement	1	1	1	
8- 3	V60011-620450	BEARING, RB/6204 Roulement	1	1	1	
8- 4	1352-217-0020-0	GEAR, MAIN SHIFT/25-39T Baladeur	1	1	1	
8- 5	1340-217-0040-0	SEAL, OIL/TC22357 Bague d'étanchéité	1	1	1	
8- 6	1352-217-0030-0	SEAL, OIL/TC25358 Bague d'étanchéité	1	1	1	
8- 7	1352-217-0040-0	BUSH, SEAL Cousinet	1	1	1	
8- 8	V73519-230420	PIPE/VINYL Cousinet	1		1	{ No. 1-8970 ENo. 1-7370
8- 9	1352-219-1000-0	SHAFT, SHIFT Arbre secondaire	1	1	1	
8-10	1352-219-0010-0	GEAR, SHIFT/26-45T Baladeur	1		1	No. 1-15800
8-10a	1365-219-0010-0	GEAR, SHIFT/36-45T Baladeur	1	1	1	No. 15801-
8-11	V60011-062030	BEARING, RB/6203 Roulement	1	1	1	
8-12	V60011-620450	BEARING, RB/6204 Roulement	1	1	1	
8-13	1340-217-0040-0	SEAL, OIL/TC22357 Bague d'étanchéité	1	1	1	
8-14	1352-222-0010-0	PIN, COUNTER GEAR Axe de pignon fou	1	1	1	
8-15	1352-222-0020-0	GEAR, IDLE/72T Pignon fou	1	1	1	
8-16	V60011-062020	BEARING, RB/6202 Roulement	2	2	2	
8-17	1365-224-0010-0	SHAFT, WHEEL PINION Arbre de clabots	1	1	1	
8-18	V60011-063040	BEARING, RB/6304 Roulement	2	2	2	
8-19	V70414-002000	RING, SNAP/C 20 Collet d'axe	2	2	2	
8-20	1365-224-0020-0	WASHER Rondelle	4	4	4	2 pieces use for No. 1-3200
8-21	1352-224-0020-0	SPRING, PRESS/35 Ressort de pression	2	2	2	
8-22	1365-224-0030-0	PINION, WHEEL/11T Clabot	2	2	2	
8-23	1352-224-0040-0	GEAR, SIDE CLUTCH/62T Roue de clabotage	1	1	1	
8-24	V70514-003500	RING, SNAP/C 35 Collet d'axe	2	2	2	
8-25	1365-225-1000-0	SHAFT, WHEEL Fusse	2	2	2	
8-26	1310-225-0050-0	PIN, WHEEL SHAFT Arbre de roues	1	1	1	
8-27	V60011-062080	BEARING, RB/6208 Roulement	2	2	2	
8-28	1365-225-0010-0	SEAL, OIL/AQ6952E Bague d'étanchéité	2	2	2	
8-29	1352-226-1000-0	GEAR, BACK/22T Pignon de M AR	1	1	1	
8-30	1352-226-0010-0	PIN, BACK GEAR Axe de M AR	1	1	1	
8-31	V72010-240100	O-RING/P10A Joint torique	1	1	1	
8-32	1338-216-0070-0	PLATE, LOCK B Plaque arretoir	1		1	No. 1-15800
8-32a	1365-226-0010-0	PLATE, LOCK Plaque arretoir	1	1	1	No. 15801-
8-33	V20026-060120	BOLT/M6×12 Vis	2	2	2	
8-34	V40116-000600	WASHER, SP/M6 Rondelle frein	2	2	2	
8-35	1352-917-0010-0	PULLEY/100 Poulie	1	1	1	
8-36	1324-205-0020-0	WASHER Rondelle	1	1	1	

Fig. 8

TRANSMISSION GEAR  
Reducteur

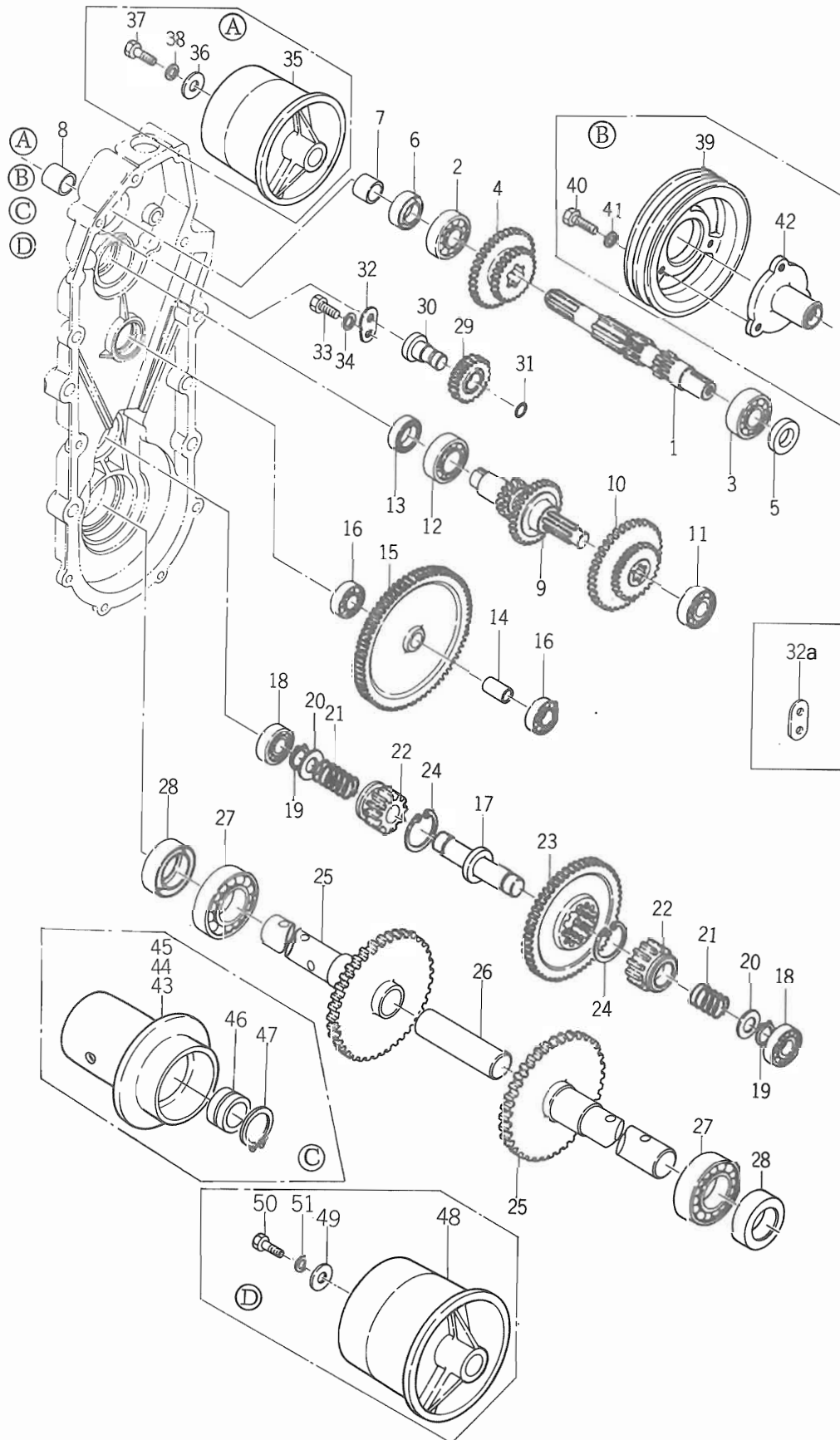

Ref No. Réf N°.	Parts No. Pièces N°.	Description Désignation	Model & Q'ty Modél & Quant			Remarks Remarques
			KS 650	KS 650D	KS 650E	
8-37	V20126-080200	BOLT/M8×20 Vis	1	1	1	
8-38	V40116-000800	WASHER, SP/M8 Rondelle frein	1	1	1	
8-39	1352-917-0030-0	PULLEY, V/2-140 Poulie trapezoidale	1	1		
8-40	V20126-080200	BOLT/M8×20 Vis	3	3		
8-41	V40116-000800	WASHER, SP/M8 Rondelle frein	3	3		
8-42	1352-917-0040-0	BOSS, PULLEY Moyeu de poulie	1	1		
8-43	1366-917-0010-0	PULLEY/75 Poulie	1	1		
8-44	1366-917-0020-0	PULLEY/90 Poulie	1	1		
8-45	1366-917-0030-0	PULLEY/100 Poulie	1	1		
8-46	1371-217-0010-0	COLLAR Collier	1	1		
8-47	1371-217-0020-0	RING, SNAP/C WR47 Collet d'axe	1	1		
8-48	1352-917-0050-0	PULLEY/140 Poulie	1			
8-49	1324-205-0020-0	WASHER Rondelle	1			
8-50	V20126-080200	BOLT/M8×20 Vis	1			
8-51	V40116-000800	WASHER, SP/M8 Rondelle frein	1			

Fig. 9

SHIFTER  
Fourchettes

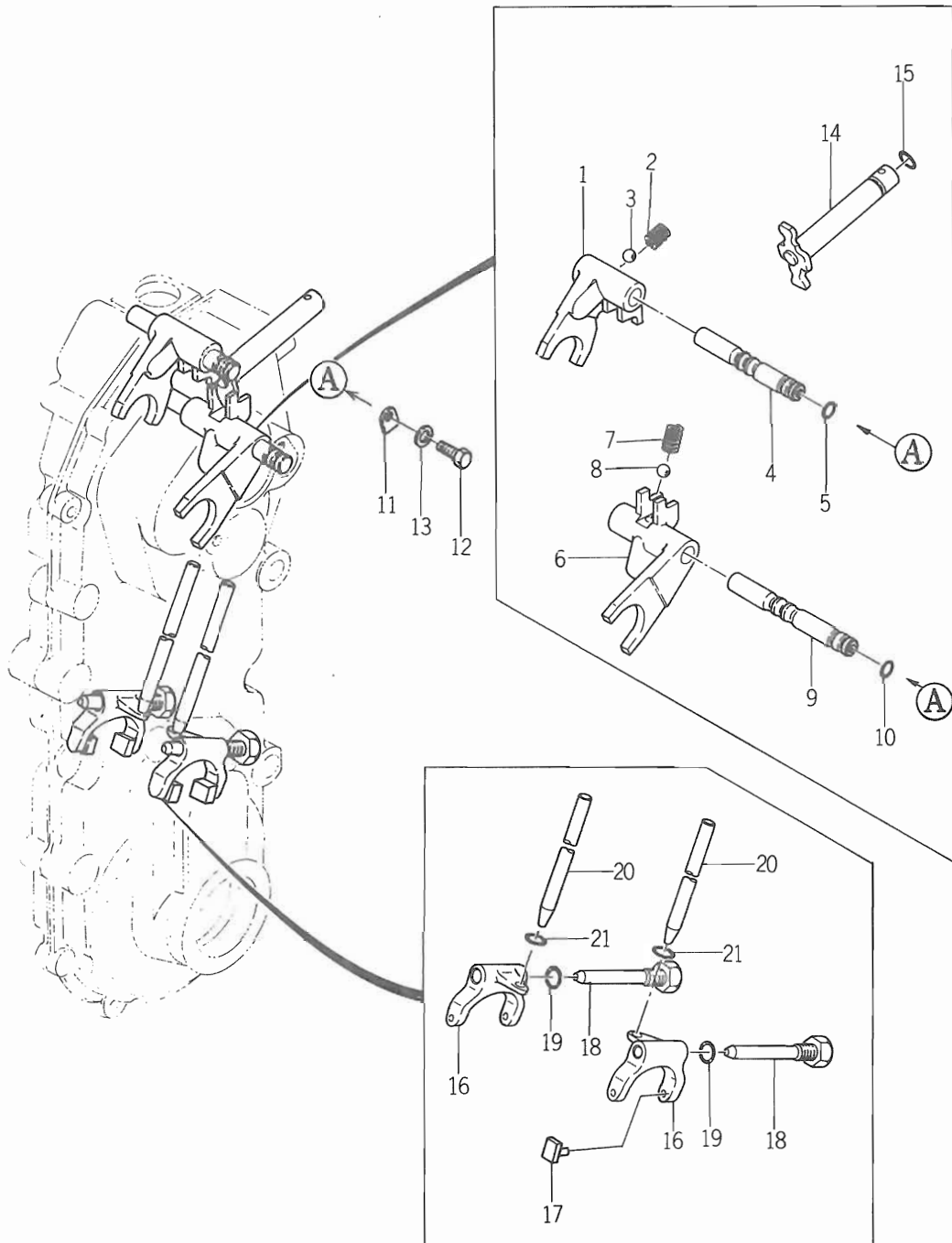

Ref No. Réf N°.	Parts No. Pièces N°.	Description Désignation	Model & Q'ty Modél & Quant			Remarks Remarques
			KS 650	KS 650D	KS 650E	
9- 1	1352-229-0010-0	SHIFTER, MAIN SHIFT Fourchette de M AV	1	1	1	
9- 2	1302-225-0030-0	SPRING, SHIFTER Ressort de verrouillage	1	1	1	
9- 3	V68010-000100	BALL, STEEL Bille de verrouillage	1	1	1	
9- 4	1352-229-0020-0	STAY, MAIN SHIFTER Axe de fourchette	1	1	1	
9- 5	V72010-190090	O-RING/P9 Joint torique	1	1	1	
9- 6	1352-229-0030-0	SHIFTER, BACK Fourchette de M AR	1	1		{ No. 1-15800 DNo. 1-103900 { No. 15801- DNo. 103901-
9- 6a	1352-229-0031-0	SHIFTER, BACK Fourchette de M AR	1	1	1	
9- 7	1302-225-0030-0	SPRING, SHIFTER Ressort de verrouillage	1	1	1	
9- 8	V68010-000100	BALL, STEEL Bille de verrouillage	1	1	1	
9- 9	1352-229-0040-0	STAY, BACK SHIFTER Axe de fourchette	1	1	1	
9-10	V72010-190090	O-RING/P9 Joint torique	1	1	1	
9-11	1352-229-0050-0	PLATE, STAY SET Butée	2	2	2	
9-12	V20026-060120	BOLT/M6×12 Vis	2	2	2	
9-13	V40116-000600	WASHER, SP/M6 Rondelle frein	2	2	2	
9-14	1352-229-1000-0	ARM, SHIFT Selecteur	1	1	1	
9-15	V72010-240160	O-RING/P16 Joint torique	1	1	1	
9-16	1365-229-0010-0	SHIFTER, SIDE CLUTCH Fourchette de clabotage	2	2	2	
9-17	2703-101-0200-0	COLLAR, SHIFTER Griffe de frottement	4	4	4	
9-18	1352-229-0060-0	PIN, SIDE CLUTCH Pivot	2	2	2	
9-19	V72010-240100	O-RING/P10A Joint torique	2	2	2	
9-20	1352-229-0070-0	ROD, SIDE CLUTCH Doigt	2	2	2	
9-21	V72010-190100	O-RING/P10 Joint torique	2	2	2	

Fig. 10

SUB TRANSMISSION  
Boîte de vitesses sub.

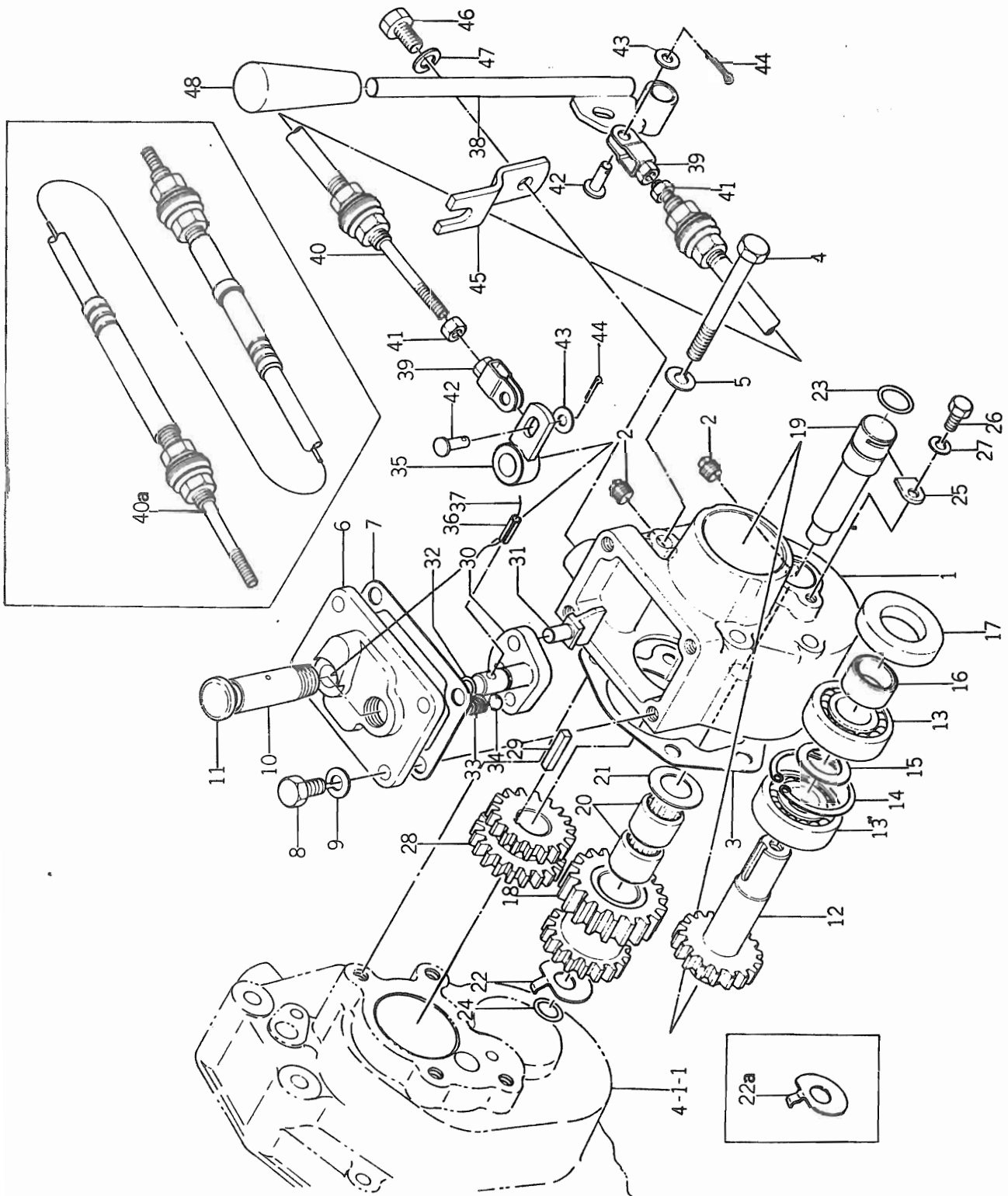



Ref No. Réf No.	Parts No. Pièces No.	Description Désignation	Model & Q'ty Modél & Quant			Remarks Remarques
			KS 650	KS 650D	KS 650E	
10- 1	1371-211-0010-0	CASE, SUB TRANSMISSION Coquille		1		DNo. 1-15800
10- 1a	1371-211-0011-0	CASE, SUB TRANSMISSION Coquille		1		DNo. 15801-
10- 2	V78130-000020	PLUG Bouchon		2		
10- 3	1371-211-0020-0	PACKING, CASE Joint		1		DNo. 1-15800
10- 3a	1371-211-0021-0	PACKING, CASE Joint		1		DNo. 15801-
10- 4	V20126-080750	BOLT/M8 × 75 Vis		4		
10- 5	V40116-000800	WASHER, SP/M8 Rondelle frein		4		
10- 6	1371-211-0030-0	COVER, SUB CASE Sous-cathe		1		
10- 7	1371-211-0040-0	PACKING, COVER Joint		1		
10- 8	V20126-080200	BOLT/M8 × 20 Vis		4		
10- 9	V40126-000800	WASHER, SP/M8 Rondelle frein		4		
10-10	1371-211-0050-0	PIPE, BREATHER Tubulure		1		
10-11	1340-211-0051-0	CAP, OIL Bouchon		1		
10-12	1371-211-0060-0	SHAFT, PULLEY Arbre		1		
10-13	V60011-062040	BEARING, RB/6204 Roulement		2		
10-14	V70310-004700	RING, SNAP/B 47 Collet d'axe		1		
10-15	1371-211-0070-0	WASHER/21 × 30 × 2 Rondelle		1		
10-16	1352-217-0040-0	BUSH, SEAL Cousinnet		1		
10-17	V74412-547080	SEAL, OIL/TC25478 Bague d'étanchéité		1		
10-18	1371-211-0080-0	GEAR, SUB COUNTER/17-20T Pignon		1		
10-19	1371-211-0090-0	SHAFT, SUB COUNTER Arbre		1		
10-20	V65341-624200	BEARING, NR/TA1620 Roulement		2		
10-21	1371-211-0100-0	WASHER/17 × 30 × 2 Rondelle		1		
10-22	1371-211-0110-0	WASHER, LOCK Rondelle		1		DNo. 1-15800
10-22a	1371-211-0111-0	WASHER, LOCK Rondelle		1		DNo. 15801-
10-23	V72010-240160	O-RING Joint torique		1		
10-24	1371-211-0150-0	O-RING/S12 Joint torique		1		
10-25	1371-211-0120-0	PLATE, SET Plaque		1		
10-26	V20026-060120	BOLT/M6 × 12 Vis		1		
10-27	V40116-000600	WASHER, SP/M6 Rondelle frein		1		
10-28	1371-211-0130-0	GEAR, SUB SHIFT/17-19T Pignon		1		
10-29	1317-201-0040-0	KEY, PULLEY Clavette		1		
10-30	1371-211-1000-0	ARM, SUB SHIFT Selecteur		1		
10-31	1371-211-0140-0	SHIFTER, SUB Fourchette		1		
10-32	V72010-190090	O-RING/P9 Joint torique		1		
10-33	1302-225-0030-0	SPRING, SHIFTER Ressort de verrouillage		1		
10-34	V68010-000100	BALL, STEEL Bille de verrouillage		1		
10-35	1371-211-2000-0	ARM, SUB		1		

Fig. 10 SUB TRANSMISSION  
Boite de vitesses sub.

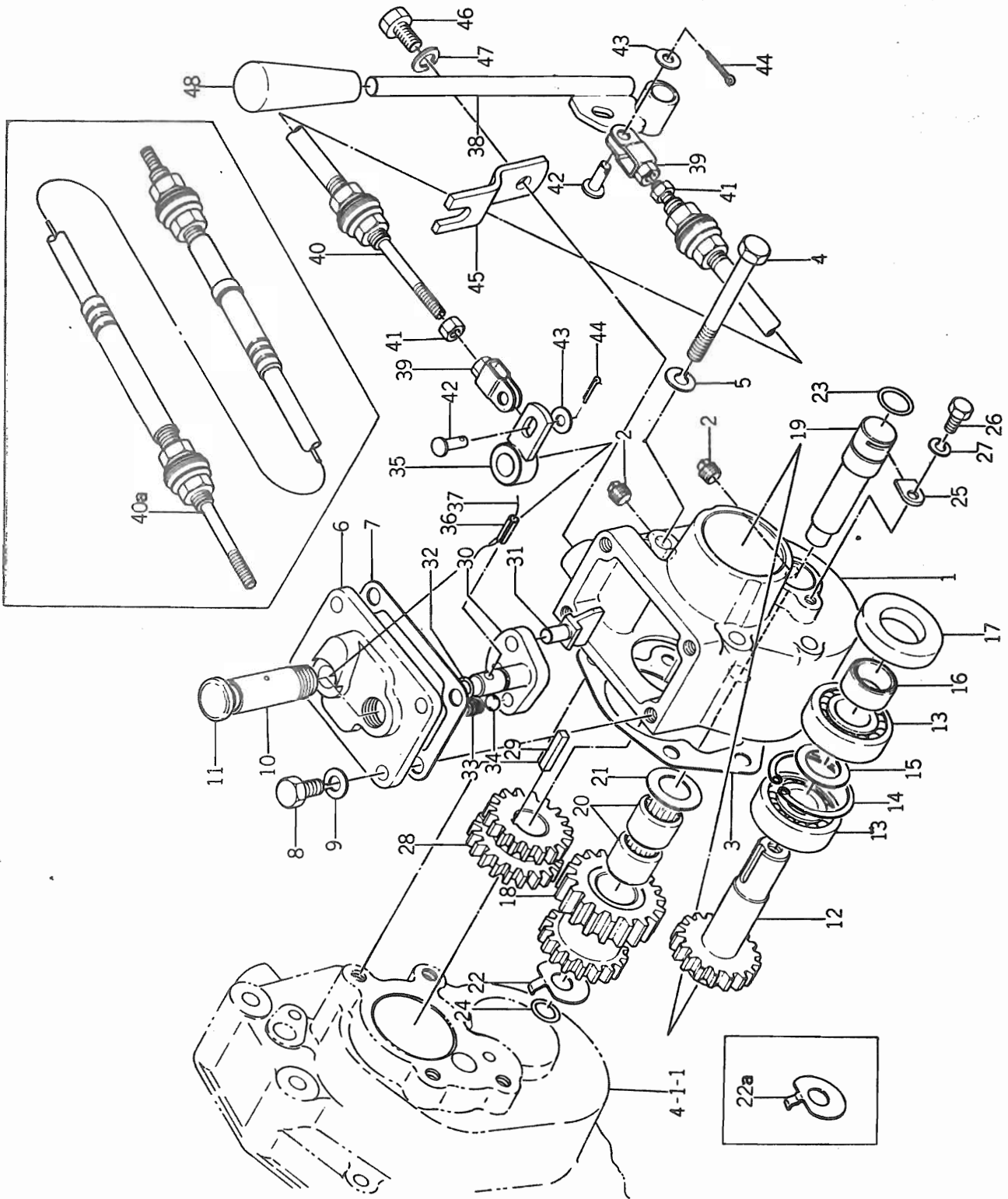

Ref No. Réf N°	Parts No. Pièces N°	Description Désignation	Model & Q'ty Modél & Quant			Remarks Remarques
			Ks 650	Ks 650D	Ks 650E	
10-36	V58014-050240	PIN, SPRING/5×24 Goupille elastique			1	
10-37	V59013-090700	WIRE/0.9×70 Fil			1	
10-38	1371-401-2000-0	LEVER, SUB SHIFT Lever			1	
10-39	1371-401-3000-0	YOKE Chape			2	
10-40	1371-401-0010-0	WIRE, SUB SHIFT ASSY Cable			1	DNo. 1-114150
10-40a	1371-401-0011-0	WIRE, SUB SHIFT ASSY Cable			1	DNo. 114151-
10-41	V30026-000600	NUT/M6 Erou			2	
10-42	3502-201-0040-0	PIN, JOINT Goupille			2	
10-43	V41316-000600	WASHER, PL/M6 Rondelle			2	
10-44	V50015-200150	PIN, SPLIT/2×15 Goupille fendue			2	
10-45	1371-401-0020-0	ARM, WIRE Equerre d'arret			1	
10-46	V20126-080200	BOLT/M8×20 Vis			1	
10-47	V40116-000800	WASHER, SP/M8 Rondelle frein			1	
10-48	4106-105-3030-0	GRIP Poignee			1	
10-48a	2101-230-0010-0	GRIP Poignee			1	Ⓐ

Fig. 11

TENSION AND BRAKE SYSTEM  
Embrayage & frein

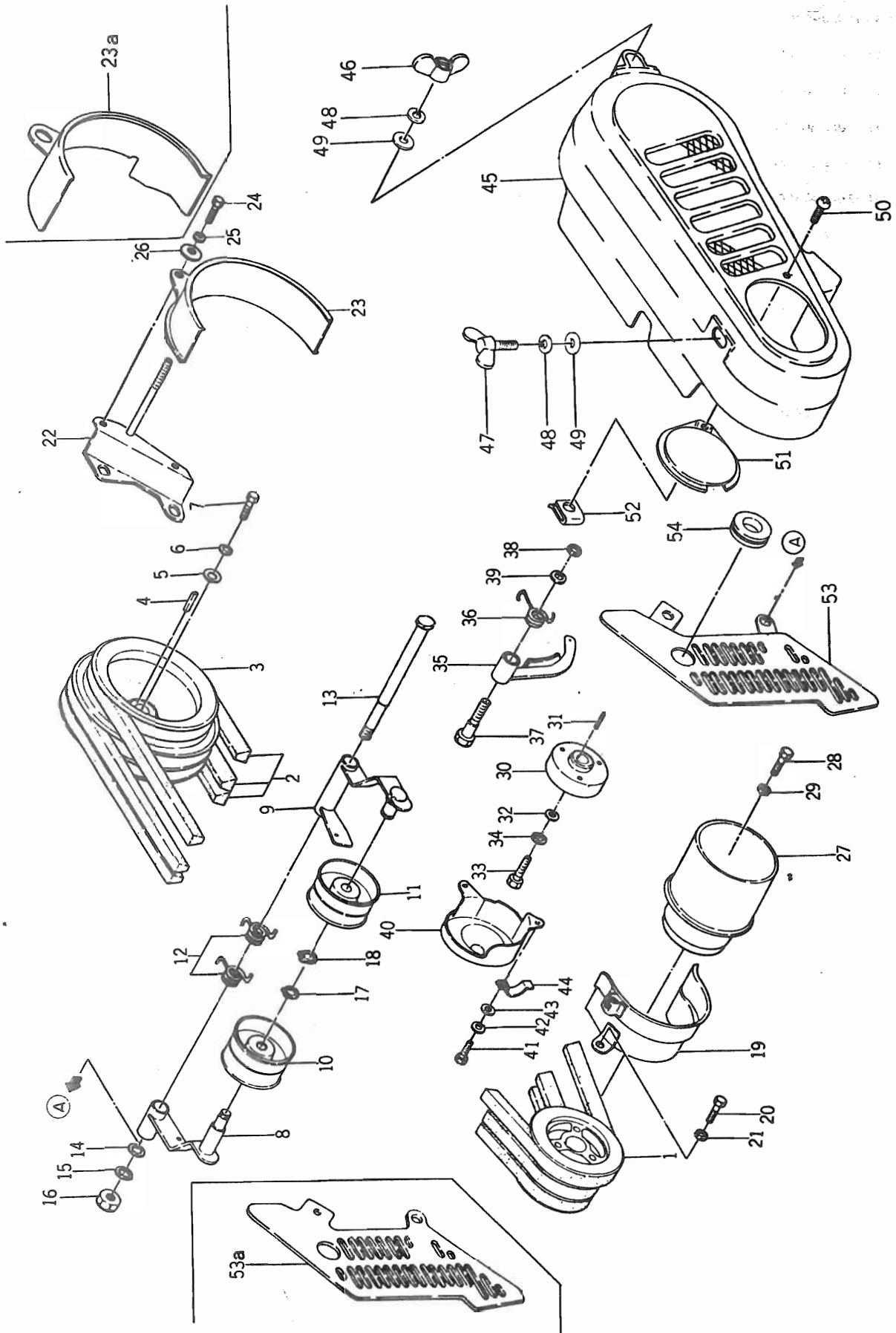

Fig. 11 TENSION AND BRAKE SYSTEM  
Embrayage & frein

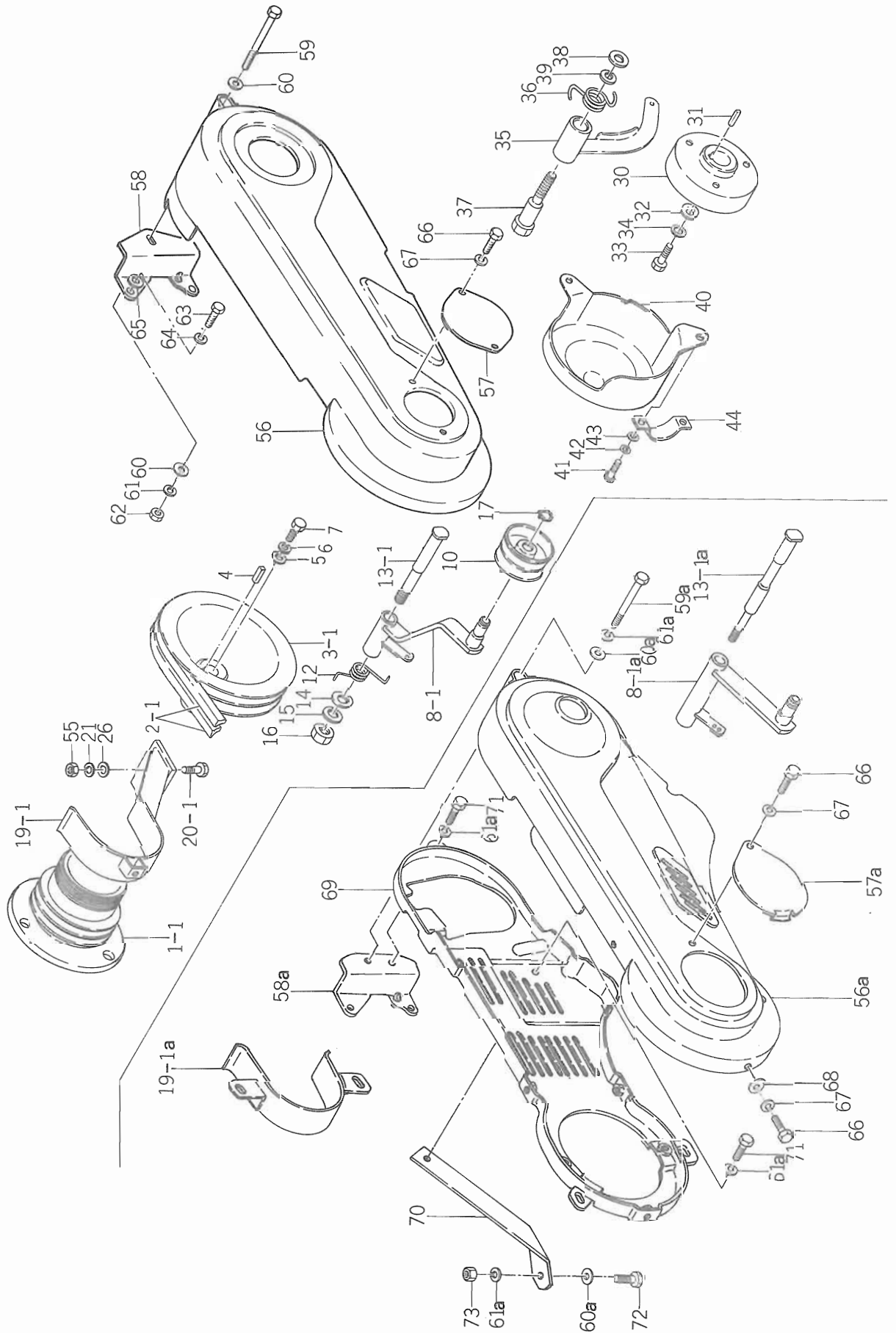
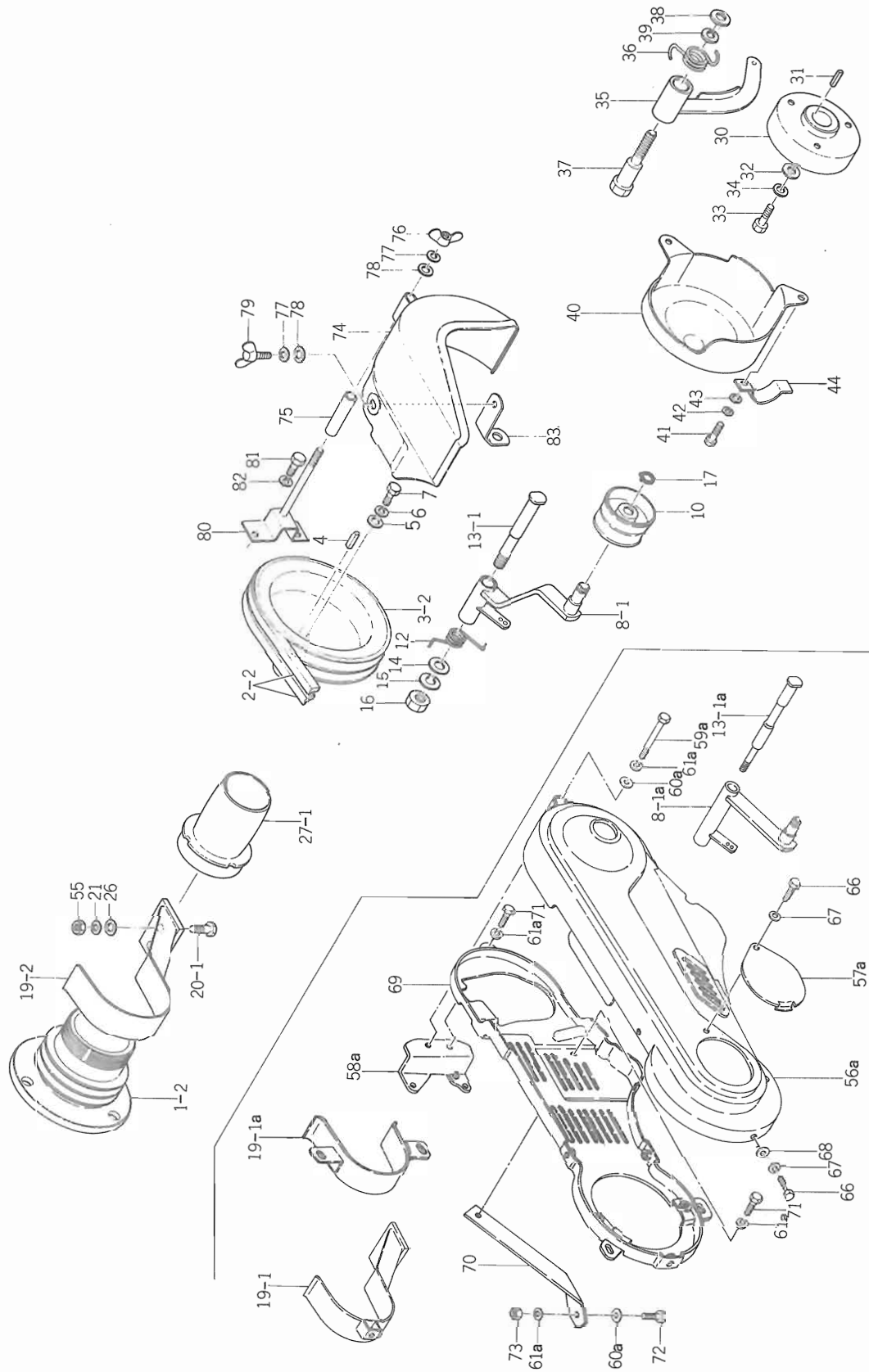

Fig. 11

TENSION AND BRAKE SYSTEM  
Embrayage & frein



Ref No. Réf No.	Parts No. Pièces No.	Description Désignation	Model & Q'ty Modél & Quant			Remarks Remarques
			KS 650	KS 650D	KS 650E	
11- 1	1365-201-0010-0	PULLEY, ENGINE/98 Poulie motrice	1			
11- 1-1	1371-202-0010-0	PULLEY, ENGINE/80 Poulie motrice		1		
11- 1-2	1368-202-0010-0	PULLEY, ENGINE/74 Poulie motrice			1	
11- 2	1365-201-0030-0	BELT, V/SB39 Courroie trapezoidale	3			
11- 2-1	V81720-005300	BELT, V/SP53 Courroie trapezoidale		2		
11- 2-2	V81720-005200	BELT, V/SB52 Courroie trapezoidale			2	
11- 3	1365-201-0020-0	PULLEY, V/146-162 Poulie menee	1			
11- 3-1	1371-202-0020-0	PULLEY, V/162 Poulie menee		1		
11- 3-2	1368-202-0020-0	PULLEY, V/162 Poulie menee			1	
11- 4	1317-201-0040-0	KEY, PULLEY Clavette	1	1	1	
11- 5	1324-205-0020-0	WASHER Rondelle	1	1	1	
11- 6	V40116-000800	WASHER, SP/M8 Rondelle frein	1	1	1	
11- 7	V20126-080200	BOLT/M8×20 Vis	1	1	1	
11- 8	1365-202-1000-0	ARM, TENSION A Bras de tension	1			
11- 8-1	1368-203-1000-0	ARM, TENSION A Bras de tension		1	1	{ DNo. 1-103900 E No. 1-14970
11- 8-1a	1371-203-2000-0	ARM, TENSION A Bras de tension		1	1	{ DNo. 103901- E No. 14971-
11- 9	1365-202-2000-0	ARM, TENSION B Bras de tension	1			
11-10	1365-202-3000-0	PULLEY, TENSION A Galet tendeur	1	1	1	
11-11	1340-203-5000-0	PULLEY, TENSION Galet tendeur	1			
11-12	1352-202-0010-0	SPRING, TORQUE/28 Ressort	2	1	1	
11-13	1365-202-0020-0	BOLT, TENSION Axe de tendeur	1			
11-13-1	1368-203-0010-0	BOLT, TENSION Axe de tendeur		1	1	{ DNo. 1-103900 E No. 1-14970
11-13-1a	1371-203-0010-0	BOLT, TENSION Axe de tendeur		1	1	{ DNo. 103901- E No. 14971-
11-14	V41015-001200	WASHER, PL/M12 Rondelle	1	1	1	
11-15	V40116-001200	WASHER, SP/M12 Rondelle frein	1	1	1	
11-16	V30026-001200	NUT/M12 Erou	1	1	1	
11-17	V70414-001200	RING, SNAP/C 12 Collet d'axe	1	1	1	
11-18	V70414-001700	RING, SNAP/C 17 Collet d'axe	1			
11-19	1365-204-1000-0	STOPPER, BELT A Garde-courroies	1			
11-19-1	1371-204-1000-0	STOPPER, BELT Garde-courroies		1	1	DNo. 1-103900
11-19-1a	1371-204-2000-0	STOPPER, BELT Garde-courroies		1	1	{ DNo. 103901- EE, EHE No. 114151-
11-19-2	1368-204-1000-0	STOPPER, BELT Garde-courroies			1	For E-type
11-20	V20126-080160	BOLT/M8×16 Vis	2			
11-20-1	V20126-080140	BOLT/M8×14 Vis		2	2	EE, EHE No. 114151-
11-21	V40116-000800	WASHER, SP/M8 Rondelle frein	2	2	2	
11-22	1365-204-2000-0	STAY, STOPPER Appui	1			
11-23	1365-204-0010-0	STOPPER, BELT B Garde-courroies	1			No. 1-14970
11-23a	1365-204-0011-0	STOPPER, BELT B Garde-courroies	1			No. 14971-

# No. 11

Ref No. Réf N°	Parts No. Pièces N°	Description Désignation	Model & Q'ty Modél & Quant			Remarks Remarques
			KS 650	KS 650D	KS 650E	
11-24	V20126-080160	BOLT/M8×16 Vis	2			
11-25	V40116-000800	WASHER, SP/M8 Rondelle frein	2			
11-26	V41316-000800	WASHER, PL/M8 Rondelle	2	2	2	
11-27	1365-917-0010-0	PULLEY/100 Poulie motrice	1			★
11-27-1	1326-917-0010-0	PULLEY/68 Poulie motrice			1	★
11-28	V20126-080250	BOLT/M8×25 Vis	3			★
11-29	V40116-000800	WASHER, SP Rondelle frein	3			★
11-30	1352-209-0010-0	DRUM, BRAKE Tambour de frein	1	1	1	
11-31	1352-209-0020-0	KEY Clavette	1	1	1	
11-32	1324-205-0020-0	WASHER Rondelle	1	1	1	
11-33	V20126-080200	BOLT/M8×20 Vis	1	1	1	
11-34	V40116-000800	WASHER, SP/M8 Rondelle frein	1	1	1	
11-35	1352-209-1000-0	SHOE, BRAKE Machoire complete	1	1	1	
11-36	1352-209-0030-0	SPRING, TORQUE/25 Ressort de torsion	1	1	1	
11-37	1352-209-0040-0	BOLT, BRAKE Pivot de frein	1	1	1	
11-38	V41316-001000	WASHER, PL/M10 Rondelle	1	1	1	
11-39	V40116-001000	WASHER, SP/M10 Rondelle frein	1	1	1	
11-40	1352-209-0051-0	COVER, BRAKE Cloche de frein	1	1	1	
11-41	V20026-060120	BOLT/M6×12 Vis	2	2	2	
11-42	V40116-000600	WASHER, SP Rondelle frein	2	2	2	
11-43	V41316-000600	WASHER, PL Rondelle	2	2	2	
11-44	1352-621-0010-0	CLAMP Bride	1	1	1	
11-45	1365-612-2000-0	COVER, BELT Carter de courroies	1			
11-46	V37016-000800	NUT, WING/M8 Ecrou a oreilles	1			
11-47	V27016-080150	BOLT, WING/M8×15 Vis a oreilles	1			
11-48	V40116-000800	WASHER, SP/M8 Rondelle frein	2			No. 14971-
11-49	V41316-000800	WASHER, PL/M8 Rondelle	2			
11-50	V11116-600100	SCREW/M6×10 Vis	1			
11-51	1365-611-0010-0	CAP, COVER Opercule	1			
11-52	1365-611-0020-0	NUT, SPEED/M6 Ecrou	1			
11-53	1365-612-2100-0	COVER, BELT SUB Grille	1			No. 1-14970
11-53a	1365-612-0010-0	COVER, BELT SUB Grille	1			No. 14971-
11-54	1338-701-0050-0	COVER/RUBBER Opercule	1			
11-55	V30026-000800	NUT/M8 Ecrou		2	2	
11-56	1371-611-1000-0	COVER, BELT Carter courroies		1		DNo. 1-103900
11-56a	1371-612-2000-0	COVER, BELT A Carter de courroies		1	1	DNo. 103901- EE, EHE No. 114151-
11-57	1338-612-0010-0	COVER, PULLEY Carter de courroies		1		DNo. 1-103900
11-57a	1371-612-0010-0	COVER, PULLEY Carter de courroies		1	1	DNo. 103901-



Ref No. Réf No.	Parts No. Pièces No.	Description Désignation	Model & Qty Modél & Quant			Remarks Remarques
			KS 650	KS 650D	KS 650E	
11-58	1371-611-0010-0	STAY, COVER Support			1	DNo. 1-103900
11-58a	1371-612-2200-0	STAY, COVER A Support			1	{ DNo. 103901- EE, EHE No. 114151-
11-59	V20126-081300	BOLT/M8×130 Vis			1	
11-59a	V20126-080900	BOLT/M8×90 Vis			1	DNo. 103901- EE, EHE No. 114151-
11-60	V41316-000800	WASHER, PL/M8 Rondelle			2	DNo. 1-103900
11-60a	V41316-000800	WASHER, PL/M8 Rondelle			4	{ DNo. 103901- EE, EHE No. 114151-
11-61	V40116-000800	WASHER, SP/M8 Rondelle frein			1	
11-61a	V40116-000800	WASHER, SP/M8 Rondelle frein			6	DNo. 1-103900
11-62	V30026-000800	NUT/M8 Ecrou			1	DNo. 103901- EE, EHE No. 114151-
11-63	V20126-100200	BOLT/M10×20 Vis			1	DNo. 1-103900
11-64	V40116-001000	WASHER, SP/M10 Rondelle frein			1	{ DNo. 1-103900
11-65	V41316-001000	WASHER, PL/M10 Rondelle			1	
11-66	V20026-060100	BOLT/M6×10 Vis			4	{
11-67	V40116-000600	WASHER, SP/M6 Rondelle frein			4	
11-68	V41316-000600	WASHER, PL/M6 Rondelle			3	
11-69	1371-612-2100-0	COVER, BELT B Carter de courroies			1	{ DNo. 103901- EE, EHE No. 114151-
11-70	1371-612-0020-0	STAY, COVER B Support			1	
11-71	V20126-080140	BOLT/M8×14 Vis			4	{
11-72	V20126-080250	BOLT/M8×25 Vis			1	
11-73	V30026-000800	NUT/M8 Ecrou			1	
11-74	1368-611-1000-0	COVER, BELT Carter de courroies			1	{
11-75	1368-611-0010-0	PIPE/58 Tubulure			1	
11-76	V37016-000800	NUT, WING/M8 Ecrou a oreilles			1	{ For E-type
11-77	V40116-000800	WASHER, SP/M8 Rondelle frein			2	
11-78	V41316-000800	WASHER, PL/M8 Rondelle			2	
11-79	V27016-080140	BOLT, WING/M8×14 Vis a oreilles			1	
11-80	1368-611-2000-0	STAY, COVER A Support			1	
11-81	V20126-080160	BOLT/M8×16 Vis			2	
11-82	V40116-000800	WASHER, SP/M8 Rondelle frein			2	
11-83	1368-611-3000-0	STAY, COVER B Support			1	

Fig. 12

HANDLE FRAME  
Mancherons

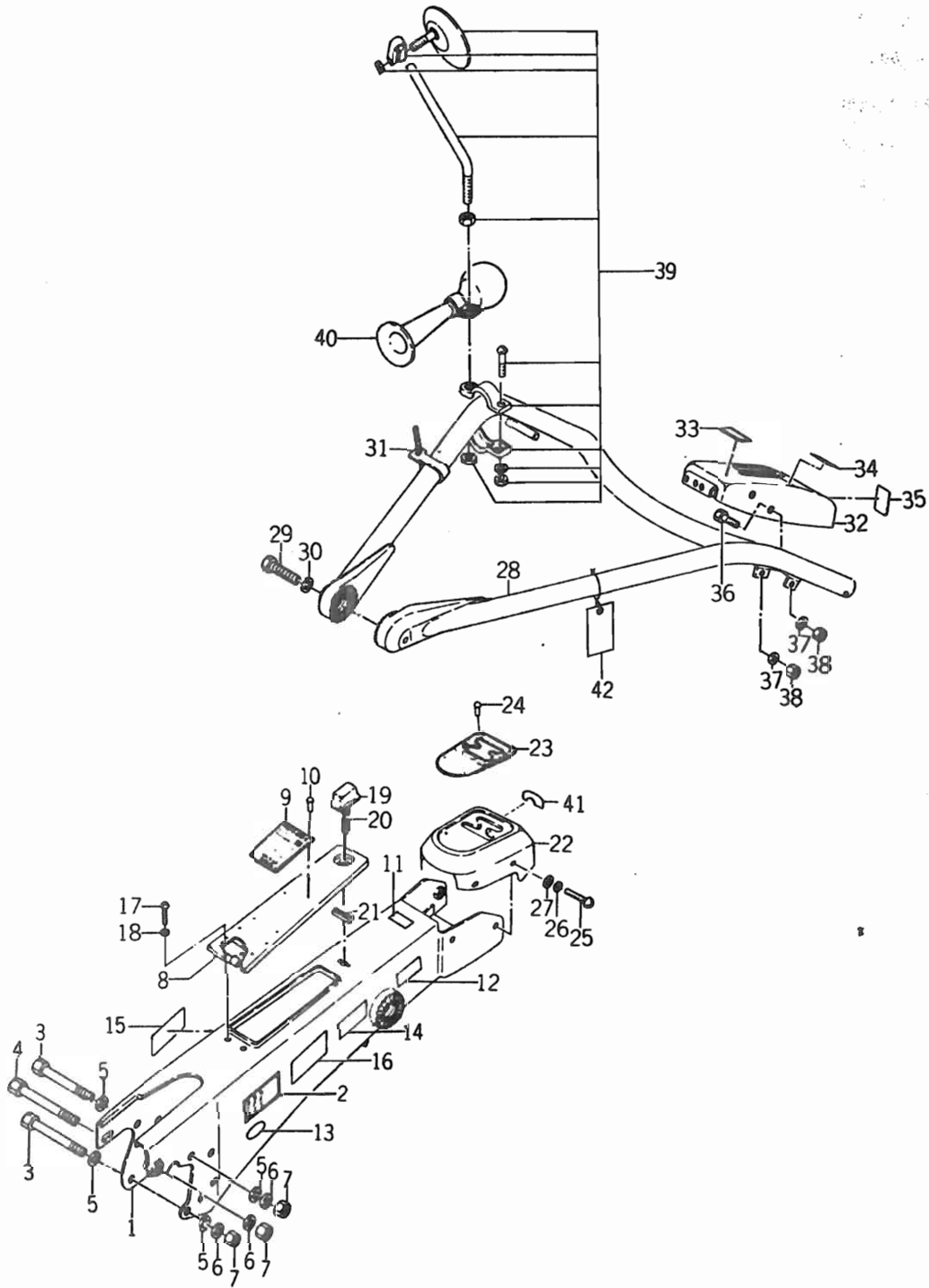

Fig. 12

HANDLE FRAME

Mancherons

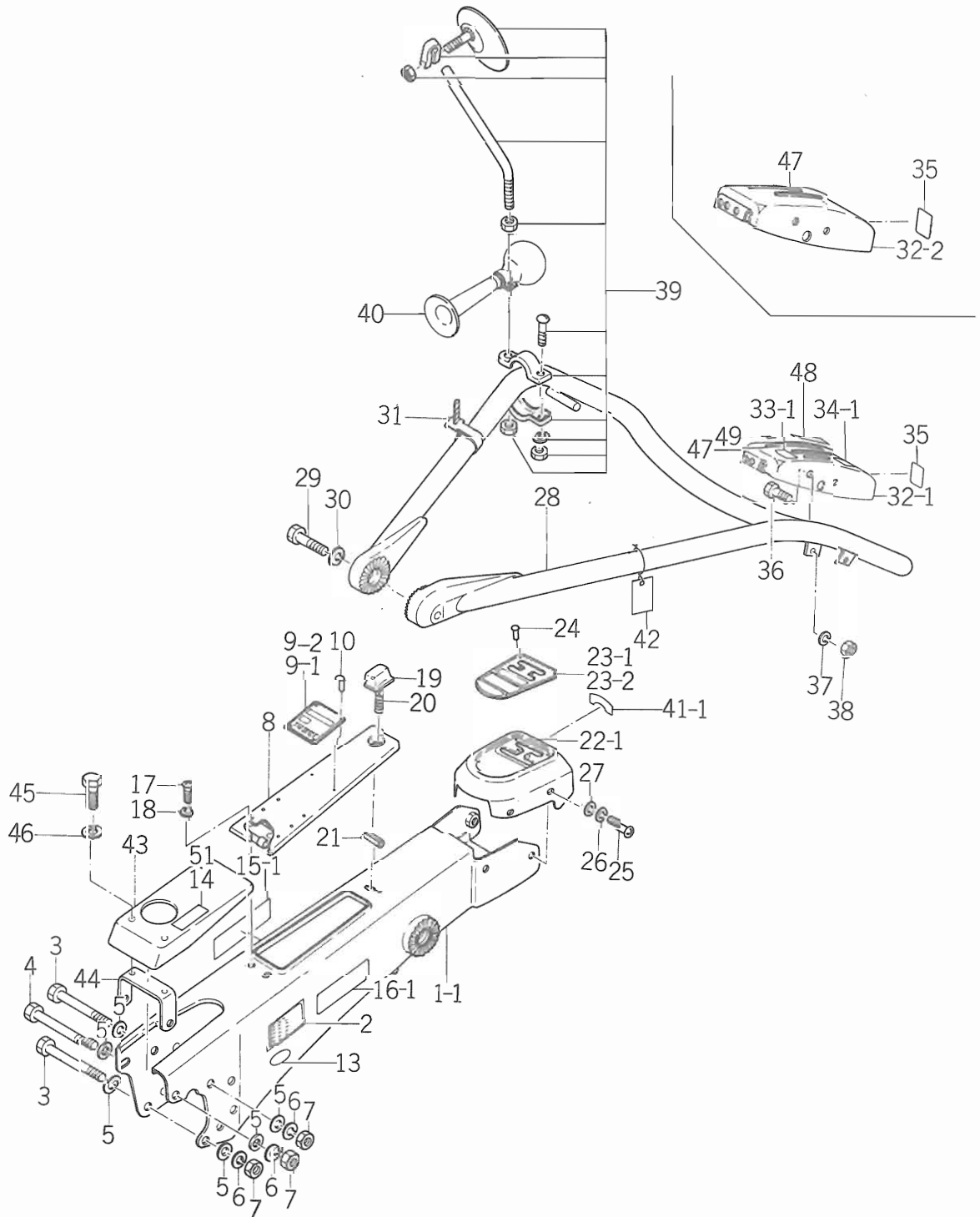
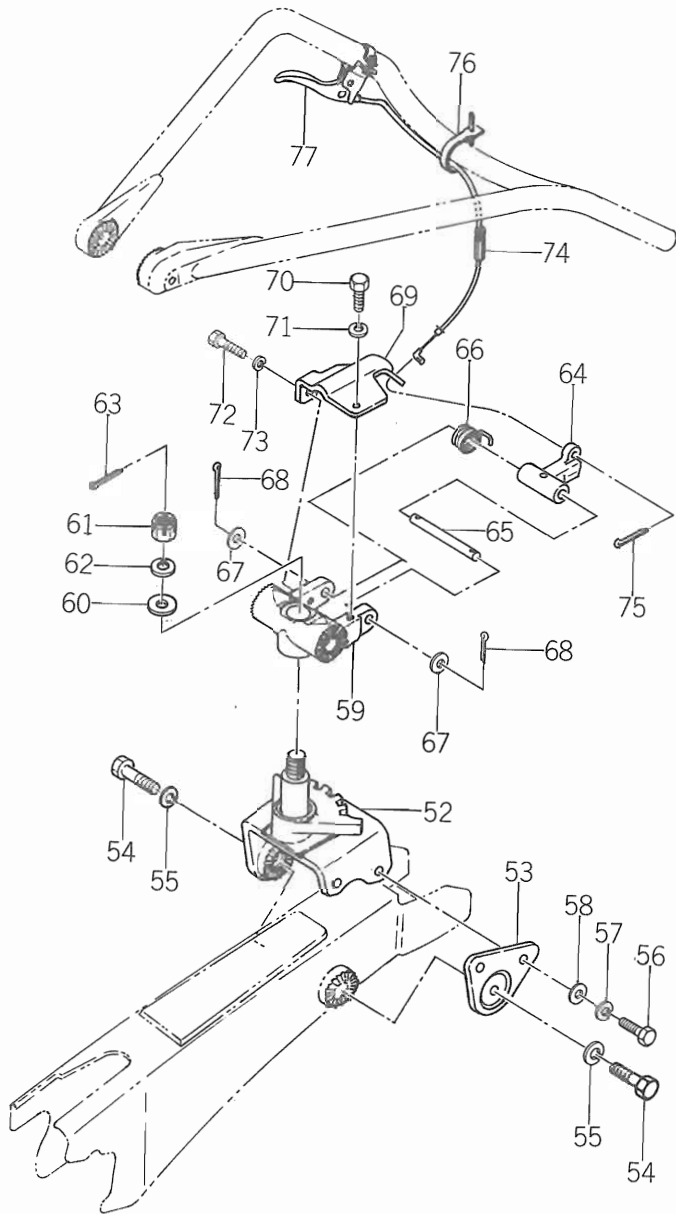

Fig. 12 HANDLE FRAME  
Mancherons



Ref No. Réf No.	Parts No. Pièces No.	Description Désignation	Model & Q'ty Model & Quant			Remarks Remarques
			KS 650	KS 650D	KS 650E	
12- 1	1365-301-1001-0	FRAME, HANDLE Age	1			
12- 1-1	1368-301-1000-0	FRAME, HANDLE Age		1	1	{ DNo. 1-1000 ENo. 1-14970
12- 1-1a	1368-301-1001-0	FRAME, HANDLE Age		1	1	{ DNo. 1001- ENo. 14971-
12- 2	1352-925-0040-0	MARK, BELT ADJ Etiquette	1	1	1	
12- 3	V20126-101200	BOLT/M10×12 Vis	2	2	2	
12- 4	V20126-101250	BOLT/M10×125 Vis	1	1	1	
12- 5	V41316-001000	WASHER, PL/M10×125 Rondelle	4	4	6	
12- 6	V40116-001000	WASHER, SP/M10 Rondelle frein	3	3	3	
12- 7	V30026-001000	NUT/M10 Erou	3	3	3	
12- 8	1365-301-2000-0	COVER, TOOL BOX Portillon	1	1	1	
12- 9	1365-951-0012-0	MARK, MODEL A Plaquette	1			
12- 9-1	1371-951-0011-0	MARK, MODEL A Plaquette		1		
12- 9-2	1368-951-0010-0	MARK, MODEL A Plaquette			1	ENo. 1-14970
12- 9-2a	1368-951-0013-0	MARK, MODEL A Plaquette			1	ENo. 14971-
12- 9-3	1365-953-0010-0	MARK, MODEL B Etiquette	1			★
12-10	V29110-200040	RIVET/2×4 Rivet	4	4	4	Ⓣ
12-11	1324-957-0120-0	MARK Etiquette	1			
12-12	1331-954-0060-0	MARK Etiquette	1			★
12-13	4114-606-0030-0	MARK, ISO Etiquette	1	1	1	{ DNo. 1301- ENo. 14971-
12-14	1368-952-0010-0	MARK Etiquette	1	1		HE No. 1-
12-15	1372-952-0010-0	MARK, CAUTION A Etiquette	1			
12-15-1	1368-953-0010-0	MARK, CAUTION A Etiquette	1	1		No. 14971-
12-16	1372-952-0020-0	MARK, CAUTION B Etiquette	1			
12-16-1	1368-953-0020-0	MARK, CAUTION B Etiquette	1	1		No. 14971-
12-17	V11116-500120	SCREW/M5×12 Vis	2	2	2	
12-18	V40116-000500	WASHER, SP/M5 Rondelle frein	2	2	2	
12-19	1352-301-0010-0	KNOB, SET Fermeture	1	1	1	
12-20	1352-301-0020-0	SPRING, PRESS Ressort	1	1	1	
12-21	V58014-030180	PIN, SPRING/3×18 Goupille elastique	1	1	1	
12-22	1352-301-3000-0	PANEL, HANDLE Grille de vitesses	1			
12-22-1	1368-301-2000-0	PANEL, HANDLE Grille de vitesses		1	1	
12-23	1365-951-0020-0	MARK, MAIN SHIFT Etiquette	1			
12-23-1	1371-951-0020-0	MARK, MAIN SHIFT Etiquette		1		
12-23-2	1368-951-0020-0	MARK, MAIN SHIFT Etiquette			1	ENo. 1-14970
12-23-2a	1368-951-0021-0	MARK, MAIN SHIFT Etiquette			1	ENo. 14971-
12-24	V29110-200060	RIVET/2×6 Rivet	6	6	6	
12-25	V11116-600120	SCREW/M6×12 Vis	4	4	4	
12-26	V40116-000600	WASHER, SP/M6 Rondelle frein	4	4	4	

# No. 12

Ref No. Réf No.	Parts No. Pièces No.	Description Désignation	Model & Q'ty Modél & Quant			Remarks Remarques
			Ks 650	Ks 650D	Ks 650E	
12-27	V41316-000600	WASHER, PL/M6 Rondelle	4	4	4	
12-28	1352-311-1000-0	PIPE, HANDLE Mancheron delta	1	1	1	
12-29	V20146-120450	BOLT/M12×45 8T Vis	2	2	2	
12-30	V40116-001200	WASHER, SP/M12 Rondelle frein	2	2	2	
12-31	1427-621-0260-0	CLAMP, HARNESS/150 Bracelet	2	2	2	
12-32	1352-404-1002-0	BOX, CLUTCH Guide d'embrayage	1			
12-32-1	1371-401-1000-0	BOX, CLUTCH Guide d'embrayage		1		
12-32-2	1368-401-1000-0	BOX, CLUTCH Guide d'embrayage			1	
12-33	1352-952-0010-0	MARK, CLUTCH A Etiquette	1			
12-33-1	1371-902-0010-0	MARK, CLUTCH A Etiquette		1		
12-34	1352-952-0020-0	MARK, CLUTCH B Etiquette	1			
12-34-1	1371-902-0020-0	MARK, CLUTCH B Etiquette		1		
12-35	1352-952-0030-0	MARK, BRAKE Etiquette	1	1	1	
12-36	V20126-080160	BOLT/M8×16 Vis	2	2	2	
12-37	V40116-000800	WASHER, SP/M8 Rondelle frein	2	2	2	
12-38	V30026-000800	NUT/M8 Ecrou	2	2	2	
12-39	1324-300-0510-0	MIRROR, R.VIEW SET Retroviseur	1	1	1	
12-40	1352-600-0520-0	HORN ASSY Corne	1	1		No. 3241;
12-41	1352-902-0070-0	MARK, SWITCH A Etiquette	1			
12-41-1	1366-902-0180-0	MARK, SWITCH Etiquette		1		
12-42	1364-902-0090-0	TAG, CAUTION Etiquette	1	1	1	
12-43	1368-301-0010-0	COVER, HANDLE Couvercle		1	1	
12-44	1368-301-3000-0	HOLDER, COVER Support		1	1	
12-45	V20026-060120	BOLT/M6×12 Vis		2	2	
12-46	V40116-000600	WASHER, SP/M6 Rondelle frein		2	2	
12-47	1351-952-0020-0	MARK, CLUTCH Etiquette		1	1	
12-48	1371-952-0010-0	MARK, SUB SHIFT A Etiquette		1		HE No. 1-
12-49	1371-952-0020-0	MARK, SUB SHIFT B Etiquette		1		
12-50	1315-621-0140-0	BAND, WIRE Sangle			2	ENo. 1-14970
12-51	1338-953-0070-0	MARK, OIL Etiquette			1	
12-0-1	1372-351-0000-0	HANDLE REVOLUTION ASSY Mancheron ensemble	1	1	1	No. 114151- ENo. 114151-
12-52	1372-351-2001-0	BRACKET Support	1	1	1	
12-53	1372-351-2100-0	PLATE, SET Plaque	1	1	1	
12-54	V20146-120450	BOLT/M12×45 9T Vis	2	2	2	
12-55	V40116-001200	WASHER, SP/M12 Rondelle frein	2	2	2	
12-56	V20146-100250	BOLT/M10×25 9T Vis	2	2	2	
12-57	V40116-001000	WASHER, SP/M10 Rondelle frein	2	2	2	
12-58	V41316-001000	WASHER, PL/M10 Rondelle	2	2	2	

Ref No. Réf No.	Parts No. Pièces No.	Description Désignation	Model & Qty Modél & Quant			Remarks Remarques
			KS 650	KS 650D	KS 650E	
12-59	1372-351-0010-0	·METAL, HANDLE BRACKET Coquille	1	1	1	
12-60	1372-351-0020-0	·WASHER/17×40×5 Rondelle	1	1	1	
12-61	V32126-001600	·NUT, SLOTTED Ecrou a creneux	1	1	1	
12-62	V40116-001600	·WASHER, SP/M16 Rondelle frein	1	1	1	
12-63	V50015-400350	·PIN, SPLIT Goupille fendue	1	1	1	
12-64	1372-351-0031-0	·METAL, LOCK Coquille arretoir	1	1	1	
12-65	1324-353-0040-0	·PIN Axe	1	1	1	
12-66	1324-353-0050-0	·SPRING, TORQUE/36 Ressort	1	1	1	
12-67	V41316-001200	·WASHER, PL/M12 Rondelle	2	2	2	
12-68	V50015-300200	·PIN, SPLIT/3×20 Goupille fendue	2	2	2	
12-69	1372-351-0040-0	·HOLDER, WIRE Cable pivot	1	1	1	
12-70	V20126-080160	·BOLT/M8×16 Vis	1	1	1	
12-71	V40116-000800	·WASHER, SP/M8 Rondelle frein	1	1	1	
12-72	V20026-060350	·BOLT/M6×35 Vis	1	1	1	
12-73	V40116-000600	·WASHER, SP/M6 Rondelle frein	1	1	1	
12-74	1372-351-0050-0	·WIRE, HANDLE LOCK Cable	1	1	1	
12-75	V50015-250150	·PIN, SPLIT/2.5×15 Goupille fendue	1	1	1	
12-76	1427-621-0260-0	·CLAMP, HANESS/150 Attache faisceau	2	2	2	
12-77	1372-351-2200-0	·LEVER, LOCK ASSY Lever	1	1	1	

**Fig. 13 CONTROL LEVER**  
**Commandes**

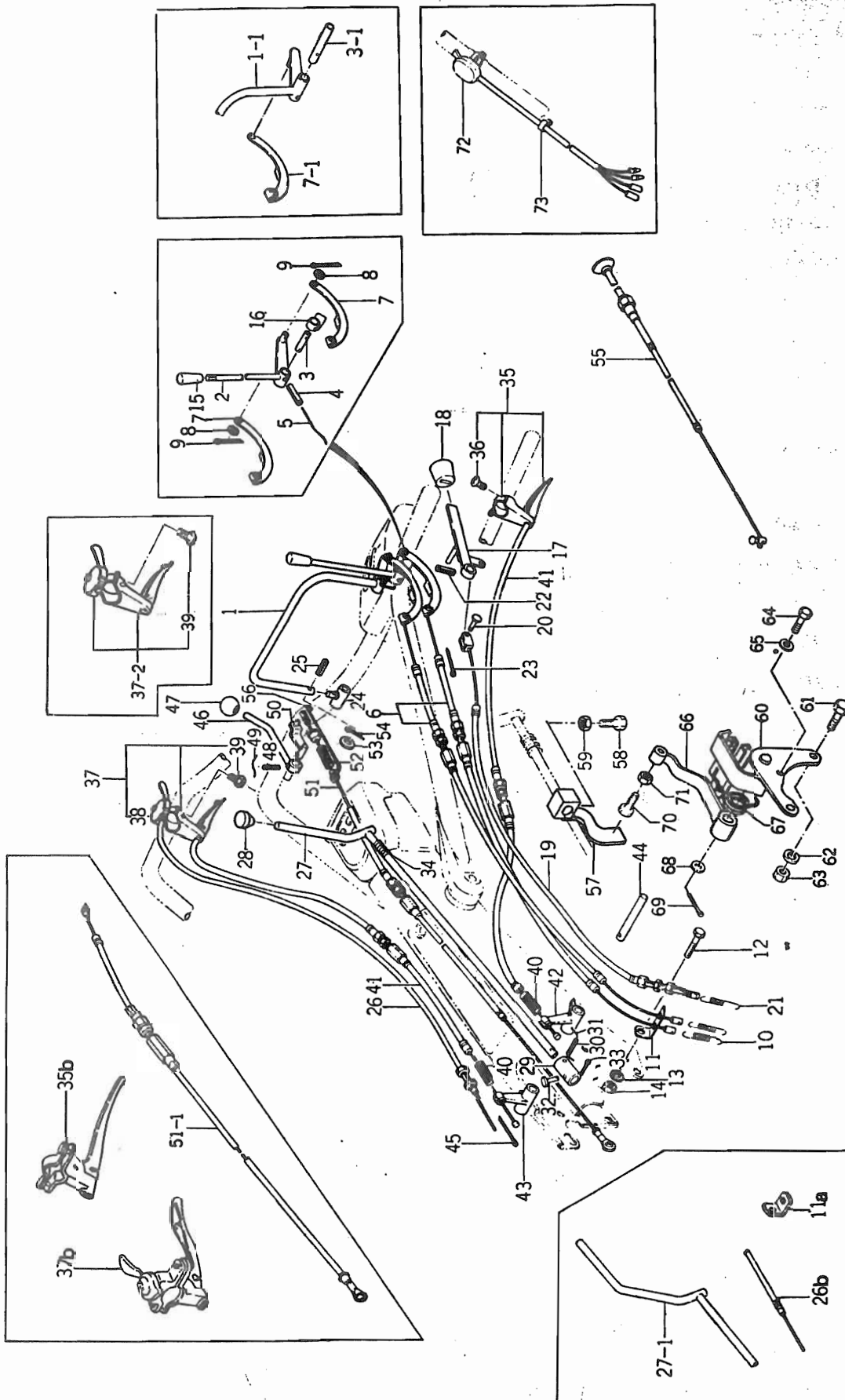



Ref No. Réf No.	Parts No. Pièces No.	Description Désignation	Model & Q'ty Modél & Quant			Remarks Remarques
			KS 650	KS 650D	KS 650E	
13- 1	1352-404-2001-0	LEVER, ARCH Arceau d'embrayage	1			
13- 1-1	1368-401-2000-0	LEVER, ARCH Arceau d'embrayage		1	1	
13- 2	1352-404-3001-0	LEVER, CLUTCH Lever d'embrayage	1			
13- 3	1352-404-0011-0	PIN, CLUTCH Axe d'embrayage	1			
13- 3-1	1368-401-0010-0	PIN, CLUTCH Axe d'embrayage		1	1	
13- 4	V58014-040220	PIN, SPRING Goupille elastique	2	1	1	
13- 5	V59013-091000	WIRE/0.9×100 Fil	2	1	1	
13- 6	1352-404-0020-0	WIRE, CLUTCH Cable d'embrayage	2	1	1	No. 1-114150
13- 6a	1372-401-0010-0	WIRE, CLUTCH Cable d'embrayage	2	1	1	No. 114151-
13- 7	1352-405-1000-0	TRIGGER, WIRE Main de cable	2			
13- 7-1	1352-405-1010-0	TRIGGER, WIRE Main de cable		1	1	
13- 8	V41316-000800	WASHER, PL/M8 Rondelle	2	1	1	
13- 9	V50016-200150	PIN, SPLIT/2×15 Goupille fendue	2	1	1	
13-10	1352-404-0040-0	SPRING, CLUTCH Ressort	2	1	1	
13-11	1352-404-0050-0	STOPPER, WIRE Equerre d'arrêt	1	1	1	{ DNo. 1-104300 { ENo. 1-19750 { DNo. 104301- { ENo. 19751-
13-11a	1371-401-0030-0	STOPPER, WIRE Equerre d'arrêt		1	1	
13-12	V20120-080750	BOLT/M8×75 Vis	1	1	1	
13-13	V40116-000800	WASHER, SP/M8 Rondelle frein	1	1	1	
13-14	V30026-000800	NUT/M8 Ecrou	1	1	1	
13-15	4106-105-3030-0	GRIP Poignee	1			
13-16	1352-404-4002-0	ARM, SHIFT A Fourchette	1			
13-17	1352-404-6002-0	LEVER, BRAKE Lever de frein	1	1	1	
13-18	1352-404-0070-0	KNOB, LEVER/24 Embout	1	1	1	
13-19	1352-404-0080-0	WIRE, BRAKE Cable de frein	1	1	1	No. 1-114150
13-19a	1372-401-0020-0	WIRE, BRAKE Cable de frein	1	1	1	No. 114151-
13-20	1352-404-0090-0	PIN/6×10 Axe	1	1	1	
13-21	1352-404-0100-0	SPRING, BRAKE Ressort	1	1	1	
13-22	V58014-030280	PIN, SPRING/3×28 Goupille elastique	1			
13-23	V50016-200150	PIN, SPLIT/2×14 Goupille fendue	1	1	1	
13-24	1352-404-8000-0	HOLDER, CLUTCH LEVER Pivot d'arceau	1	1	1	
13-25	V58014-030150	PIN, SPRING/3×15 Goupille elastique	1	1	1	
13-26	1340-402-0010-0	WIRE, THROTTLE Cable d'accelerateur	1			Engine No. 1-690 Moteur
13-26a	1365-402-0010-0	WIRE, THROTTLE Cable d'accelerateur	1			Engine No. 691- Moteur
13-26b	1326-402-0020-0	WIRE, THROTTLE Cable d'accelerateur	1			No. 114151-
13-26-1	1365-402-0020-0	WIRE, THROTTLE Cable d'accelerateur	1	1	1	
13-27	1352-403-1001-0	LEVER, SHIFT Lever de changement	1	1	1	{ GE, GE-R No. 1-14070 { DE, DE-R No. 1-103600 { E, EE No. 1-14970
13-27a	1352-403-1002-0	LEVER, SHIFT Lever de changement	1	1	1	{ GE, GE-R No. 14071- { DE, DE-R No. 103601- { E, EE No. 14971-

Fig. 13 CONTROL LEVER  
Commandes

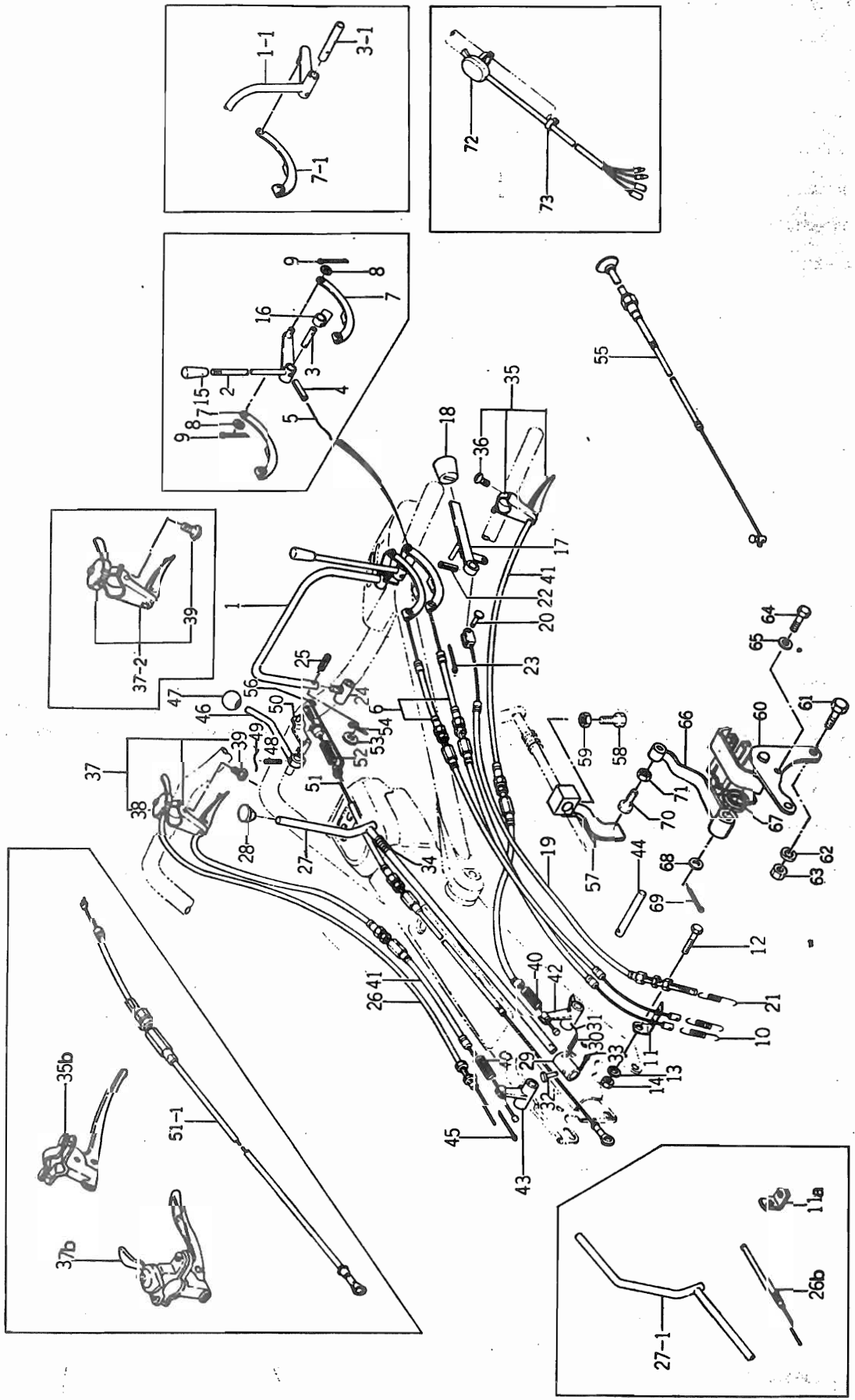

Ref No. Réf No.	Parts No. Pièces No.	Description Désignation	Model & Q'ty Modél & Quant			Remarks Remarques
			KS 650	KS 650D	KS 650E	
13-27-1	1372-451-2000-0	LEVER, SHIFT Levier de changement	1	1	1	GHE, GHE-R, EHE No. 114151- DHE, DHE-R No. 114151-
13-28	3563-102-0020-0	GRIP, SHIFT LEVER Pommeau	1	1	1	
13-29	1352-403-0010-0	JOINT Accouplement	1	1	1	GE, GE-R No. 1-14070 DE, DE-R No. 1-103600 E, EE No. 1-14970
13-29a	1352-403-0011-0	JOINT Accouplement	1	1	1	GE, GE-R No. 14071- DE, DER No. 103601- GHE, GHE-R No. 114151- E, EE No. 14971-
13-30	V58014-040280	PIN, SPRING/W 4×28 Goupille elastique	1	1	1	GE, GE-R No. 1-14070 E, EE No. 1-14970
13-30a	V58014-050280	PIN, SPRING/W 5×28 Goupille elastique	1	1	1	GE, GE-R No. 14071- GHE, GHE-R No. 114151- E, EE No. 14971-
13-31	V59013-090800	WIRE/0.9×80 Fil	1		1	GE, GE-R No. 114151- GHE, GHE-R
13-32	1352-403-0020-0	PIN/5×28 Axe	1	1	1	
13-33	V50015-160120	PIN, SPLIT/1.6×12 Goupille fendue	1	1	1	No. 1-14070 DNo. 1-101300 ENo. 1-14970 No. 14071- DNo. 101301- } 選択使用 ENo. 14971- } 13-35a can be interchangeable with 13-35b
13-34	1352-403-0030-0	SPRING, PRESS/65 Ressort de rappel	1	1	1	
13-35	1324-400-0510-0	LEVER, SIDE LH ASSY Direction G.	1	1	1	No. 1-14070 DNo. 1-101300 ENo. 1-14970 No. 14071- DNo. 101301- } 選択使用 ENo. 14971- } 13-35a can be interchangeable with 13-35b
13-35a	1352-400-0520-0	LEVER, SIDE LH ASSY Direction G.	1	1	1	
13-35b	1352-406-2000-0	LEVER, SIDE LH ASSY Direction G.	1	1	1	No. 1-6470
13-36	V10015-600250	·SCREW/M6×25 Vis	2	2	2	
13-37	1324-400-0520-0	LEVER, SIDE RH ASSY Direction D.	1			No. 6471- } 選択使用 13-37a can be interchangeable with 13-37b
13-37a	1352-400-0510-0	LEVER, SIDE RH ASSY Direction D.	1			
13-37b	1352-406-2100-0	LEVER, SIDE RH ASSY Direction D.	1			No. 1-6470
13-37-1	1371-406-2000-0	LEVER, SIDE RH ASSY Direction D.		1		
13-37-2	1368-400-0510-0	LEVER, SIDE RH ASSY Direction D.			1	No. 1-6470
13-38	1324-400-9010-0	·LEVER, THROTTLE ASSY Manettes des gaz	1			
13-39	V10015-600250	·SCREW/M6×25 Vis	2	2	2	No. 1-114150
13-40	1317-406-0020-0	SPRING, PRESS/120 Ressort	2	2	2	
13-41	1352-406-0010-0	WIRE, SIDE CLUTCH Cable de clabotage	2	2	2	No. 114151-
13-41a	1372-406-0010-0	WIRE, SIDE CLUTCH Cable de clabotage	2	2	2	
13-42	1352-406-0020-0	ARM, SIDE CLUTCH LH Etrier G.	1	1	1	No. 1-114151-
13-43	1352-406-0030-0	ARM, SIDE CLUTCH RH Etrier D.	1	1	1	
13-44	1352-406-0040-0	PIN, SIDE CLUTCH Axe d'etrier	1	1	1	No. 1-114151-
13-45	V50015-300180	PIN, SPLIT/3×18 Goupille fendue	1	1	1	
13-46	1352-416-1001-0	LEVER, STAND Lever de bequille	1	1	1	No. 1-114151-
13-47	1414-117-0040-0	KNOB, LEVER/30 Pommeau	1	1	1	
13-48	V58014-040220	PIN, SPRING/4×22 Goupille elastique	1	1	1	No. 1-114151-
13-49	V59013-090700	WIRE/0.9×70 Fil	1	1	1	
13-50	1352-416-2000-0	ARM, WIRE Bras de rappel	1	1	1	No. 1-114151-
13-51	1352-416-0011-0	WIRE, STAND Cable de bequille	1			
13-51-1	1368-416-0010-0	WIRE, STAND Cable de bequille		1	1	No. 1-114151-
13-52	1352-416-0021-0	SPRING, TENSION/63 Ressort	1	1	1	
13-53	V41016-000800	WASHER, PL/IM8 Rondelette	2	2	2	

**Fig. 13 CONTROL LEVER**  
Commandes

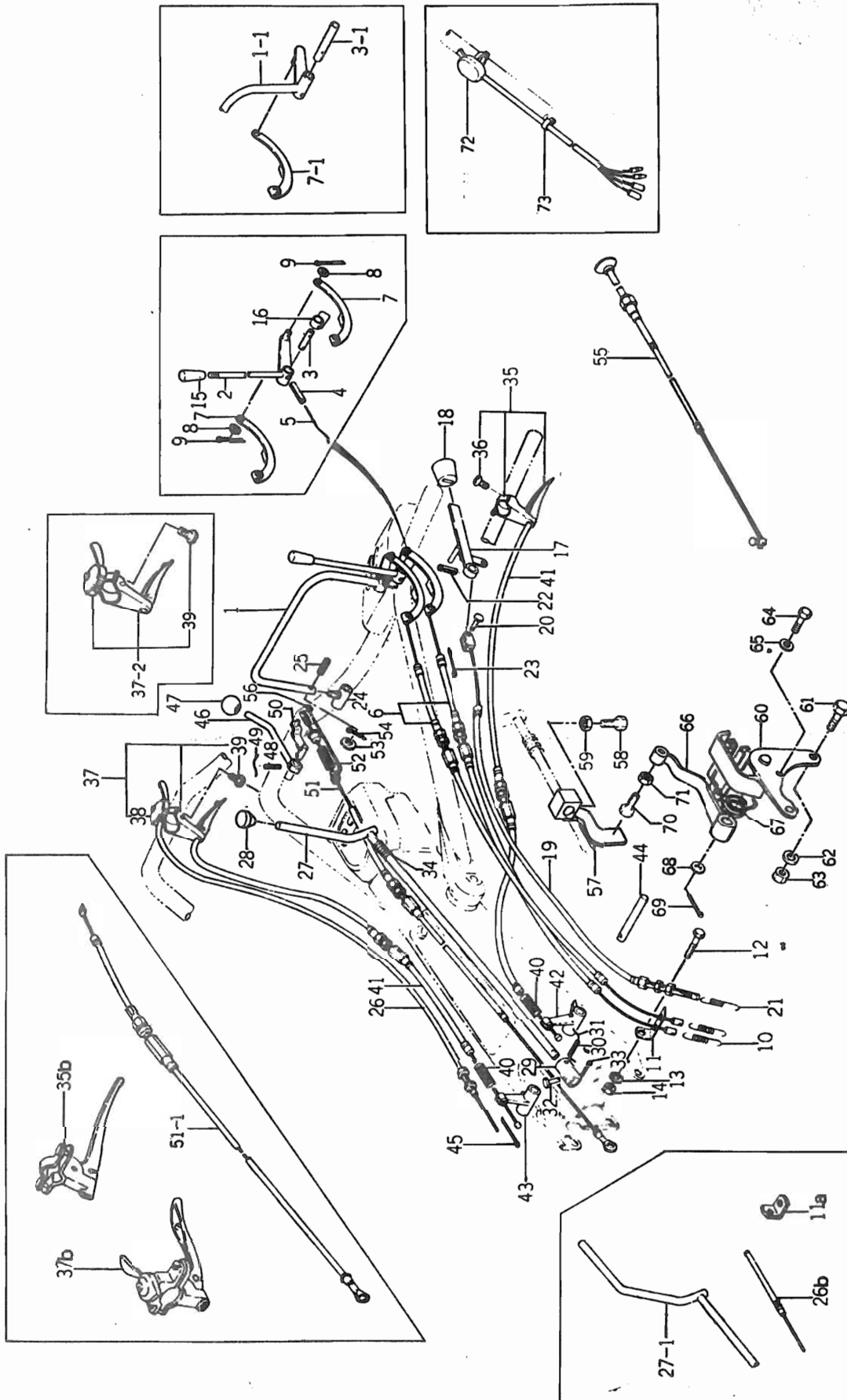

Ref No. Réf N°.	Parts No. Pièces N°.	Description Désignation	Model & Q'ty Modél & Quant			Remarks Remarques
			KS 650	KS 650D	KS 650E	
13-54	V50016-200150	PIN, SPLIT/2×15 Goupille fendue	2	2	2	
13-55	1352-402-0010-0	WIRE, CHOKE Cable de starter	1			
13-56	1352-416-0030-0	SPRING, STOPPER Limiteur	1	1	1	
13-57	1352-712-1000-0	ARM, BACKPROOF Bras de selecteur	1	1		
13-58	V20126-080200	BOLT/M8×20 Vis	1	1		
13-59	V30226-000800	NUT/M8 Erou	1	1		
13-60	1365-712-1000-0	BRACKET, LEVER Support de levier	1	1		
13-61	V20026-060200	BOLT/M6×20 Vis	1	1		
13-62	V40116-000600	WASHER, SP/M6 Rondelle frein	1	1		
13-63	V30026-000600	NUT/M6 Erou	1	1		
13-64	V20126-080200	BOLT/M8×20 Vis	2	2		No. 6471- For R-type Pour R
13-65	V40116-000800	WASHER, SP/M8 Rondelle frein	2	2		
13-66	1365-712-2000-0	LEVER, BACKPROOF Levier	1	1		
13-67	1352-712-0010-0	SPRING, TORQUE Ressort de torsion	1	1		
13-68	V41316-001200	WASHER, PL/M12 Rondelle	1	1		
13-69	V50015-300200	PIN, SPLIT/3×20 Goupille fendue	1	1		
13-70	W20126-080350	BOLT/M8×35 Vis	1	1		
13-71	V30226-000800	NUT/M8 Erou	1	1		
13-72	1366-600-0510-0	SWITCH, LIGHT ASSY Interrupteur		1	1	
13-73	1404-621-0270-0	CLAMP, WIRE HARNESS B Attache faisceau		1	1	

**Fig. 14 RECOIL STARTER**  
Lanceur

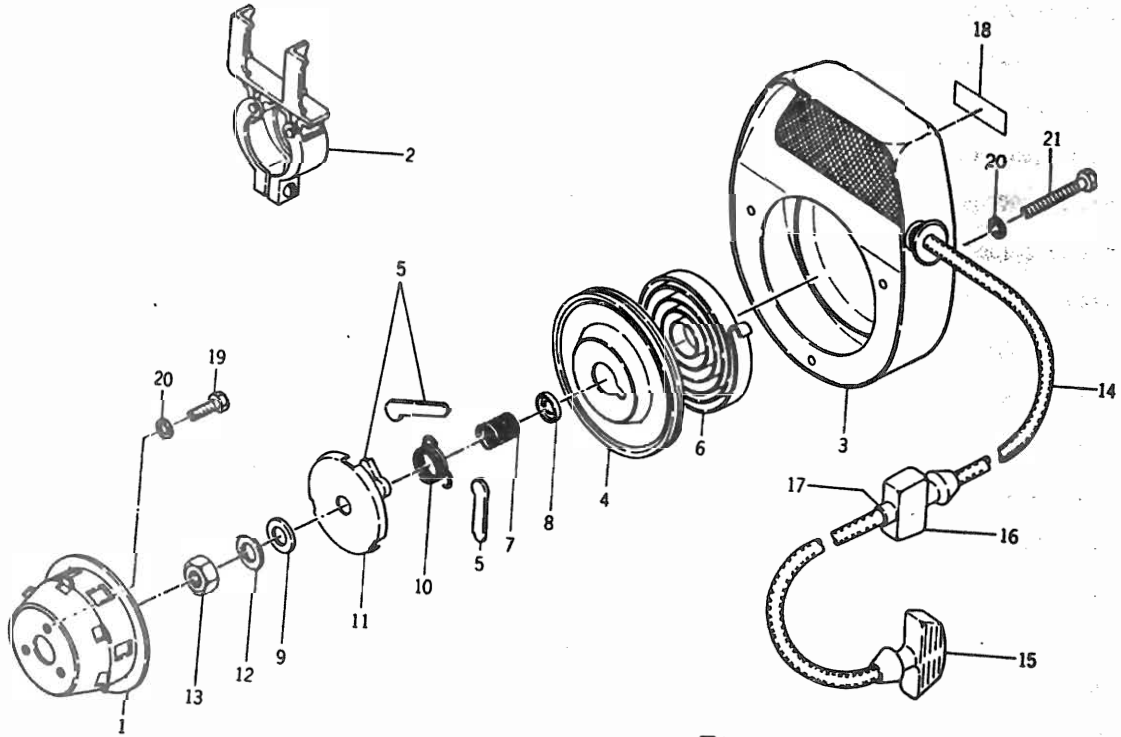

**Three ratchet type**

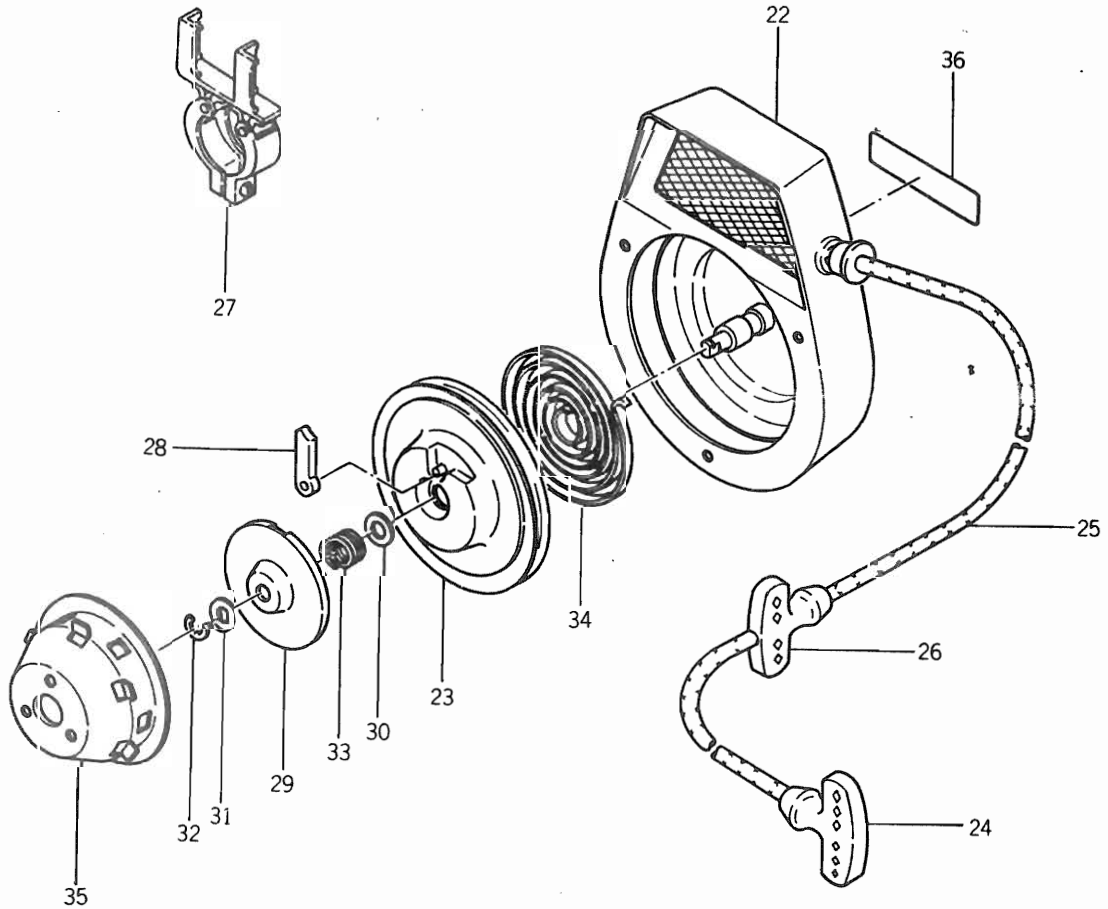

**One ratchet type**

Ref No. Réf N°.	Parts No. Pièces N°.	Description Désignation	Model & Q'ty Modél & Quant			Remarks Remarques
			KS 650	KS 650D	KS 650E	
14- 0-1	1365-100-0520-0	STARTER, RECOIL ASSY Lanceur complet	1			
14- 1	1365-121-0030-0	•PULLEY Poulie	1			
14- 2	1352-121-0080-0	•HOOK, WIRE Crochet de poignée	1			
14- 3	1365-121-0060-0	•CASE, STARTER Carter de lanceur	1			
14- 4	1365-121-0070-0	•REEL Bobine de renvidage	1			
14- 5	1365-121-0080-0	•RATCHET Cliquet	3			
14- 6	1365-121-0090-0	•SPRING, SPIRAL Ressort spirale	1			
14- 7	1374-121-0060-0	•SPRING, FRICTION Ressort de frottement	1			
14- 8	1374-121-0080-0	•WASHER Rondelle	1			
14- 9	1365-121-0120-0	•WASHER, THRUST Rondelle d'appui	1			
14-10	1374-121-0130-0	•SPRING, RETURN Ressort de rappel	1			
14-11	1365-121-0140-0	•PLATE, FRICTION Disque d'encliquetage	1			
14-12	V40116-000800	•WASHER, SP/M8 Rondelle frein	1			
14-13	V30226-000800	•NUT/M8 Erou	1			
14-14	1352-121-0050-0	•ROPE, STARTER Cordon	1			
14-15	1329-121-0140-0	•HANDLE Poignée	1			
14-16	1352-121-0060-0	•DAMPER Amortisseur de renvidage	1			
14-17	1352-121-0070-0	•PIECE, DAMPER Coupelle d'arrêt	1			
14-18	1352-151-0010-0	•MARK Etiquette	1			
14-19	V20046-060120	BOLT/M6 x 12 8T Vis	3			
14-20	V40116-000600	WASHER, SP/M6 Rondelle frein	6			
14-21	V20026-060650	BOLT/M6 x 65 Vis	3			
14- 0-1a	1365-151-2100-0	STARTER, RECOIL ASSY Lanceur complet	1			
14-22	1365-121-2110-0	•CASE, SUB: Carter de lanceur	1			
14-23	1365-121-2120-0	•REEL, SUB Bobine de renvidage	1			
14-24	1372-121-2140-0	•HANDLE, B Poignée	1			
14-25	1365-121-2130-0	•ROPE Cordon	1			
14-26	1372-121-2240-0	•HANDLE, A	1			
14-27	1372-121-2150-0	•HOOK, WIRE Crochet de poignée	1			
14-28	1372-121-2160-0	•RATCHET Cliquet	1			#25043-
14-29	1372-121-2170-0	•GUIDE, RATCHET Palier primaire	1			
14-30	1372-121-2180-0	•WASHER Rondelle	1			
14-31	1372-121-2190-0	•WASHER Rondelle	1			
14-32	1372-121-2210-0	•RING, SNAP/E Collet d'axe	1			
14-33	1372-121-2220-0	•SPRING, COIL	1			
14-34	1365-121-2140-0	•SPRING, FLAT Ressort	1			
14-35	1365-121-2150-0	•PULLEY, ENGINE Poulie motrice	1			
14-36	1372-121-2110-0	•MARK, TRADE Etiquette	1			

Fig. 15 WHEEL  
Roues

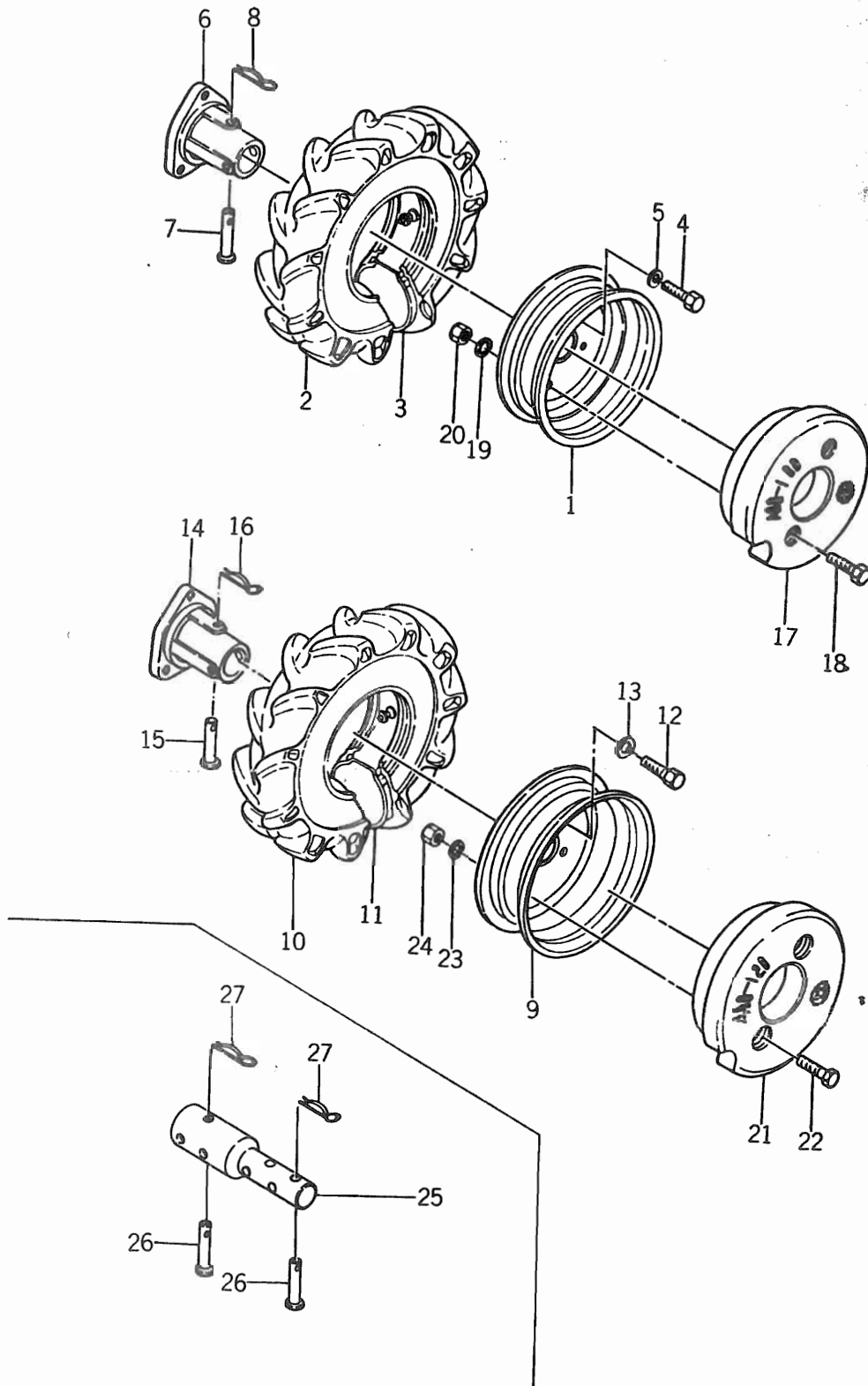



Ref No. Réf N°	Parts No. Pièces N°	Description Désignation	Model & Q'ty Modél & Quant			Remarks Remarques
			Kg 650	Kg 650D	Kg 650E	
15- 0-1	1365-024-2000-0	TIRE, LH ASSY/400-10 Roue G.	1	1	1	} EE, EHE ..... *
15- 0-2	1365-024-2100-0	TIRE, RH ASSY/400-10 Roue D.	1	1	1	
15- 1	1365-241-0010-1	·DRUM, WHEEL Jante	2	2	2	
15- 2	V88202-400100	·TIRE/400-10 Pneu	2	2	2	
15- 3	V88300-400100	·TUBE/400-10 Chambre a air	2	2	2	
15- 4	V20126-120200	BOLT/M12×20 Vis	6	6	6	
15- 5	V40116-001200	WASHER, SP/M12 Rondelle frein	6	6	6	
15- 6	1340-241-0010-0	BOSS, WHEEL Moyeu	2	2	2	
15- 7	1365-241-0020-0	PIN, HEADED Goupille	4	4	4	
15- 8	1305-241-0011-0	PIN, HAIR Attache beta	4	4	4	
15- 0-3	1365-024-3000-0	TIRE, LH ASSY/400-12 Roue G.	1	1	1	
15- 0-4	1365-024-3100-0	TIRE, RH ASSY/400-12 Roue D.	1	1	1	
15- 9	1365-242-0010-1	·DRUM, WHEEL Jante	2	2	2	
15-10	V88202-400120	·TIRE/400-12 Pneu	2	2	2	
15-11	V88300-400120	·TUBE/400-12 Chambre a air	2	2	2	
15-12	V20126-120200	BOLT/M12×20 Vis	6	6	6	
15-13	V40116-001200	WASHER, SP/M12 Rondelle frein	6	6	6	
15-14	1340-241-0010-0	BOSS, WHEEL Moyeu	2	2	2	
15-15	1365-241-0020-0	PIN, HEADED Goupille	4	4	4	
15-16	1305-241-0010-0	PIN, HAIR Attache beta	4	4	4	
15-17	1365-931-0010-0	WEIGHT, WHEEL/400-10D Masse pour roue	2	2	2	
15-18	V20126-121000	BOLT/M12×100 Vis	4	4	4	
15-19	V40116-001200	WASHER, SP/M12 Rondelle frein	4	4	4	
15-20	V30026-001200	NUT/M12 Ecrou	4	4	4	
15-21	1365-931-0020-0	WEIGHT, WHEEL/400-12D Masse pour roue	2	2	2	
15-22	V20126-121000	BOLT/M12×100 Vis	4	4	4	
15-23	V40116-001200	WASHER, SP/M12 Rondelle frein	4	4	4	
15-24	V30026-001200	NUT/M12 Ecrou	4	4	4	
15-25	1365-225-0020-0	SHAFT, SUB WHEEL Arbre	2	2	2	
15-26	1365-241-0020-0	PIN, HEADED Goupille	4	4	4	
15-27	1305-241-0010-0	PIN, HAIR Attache beta	4	4	4	

Fig. 16

COUNTER CHAIN CASE  
Chaîne intermédiaire

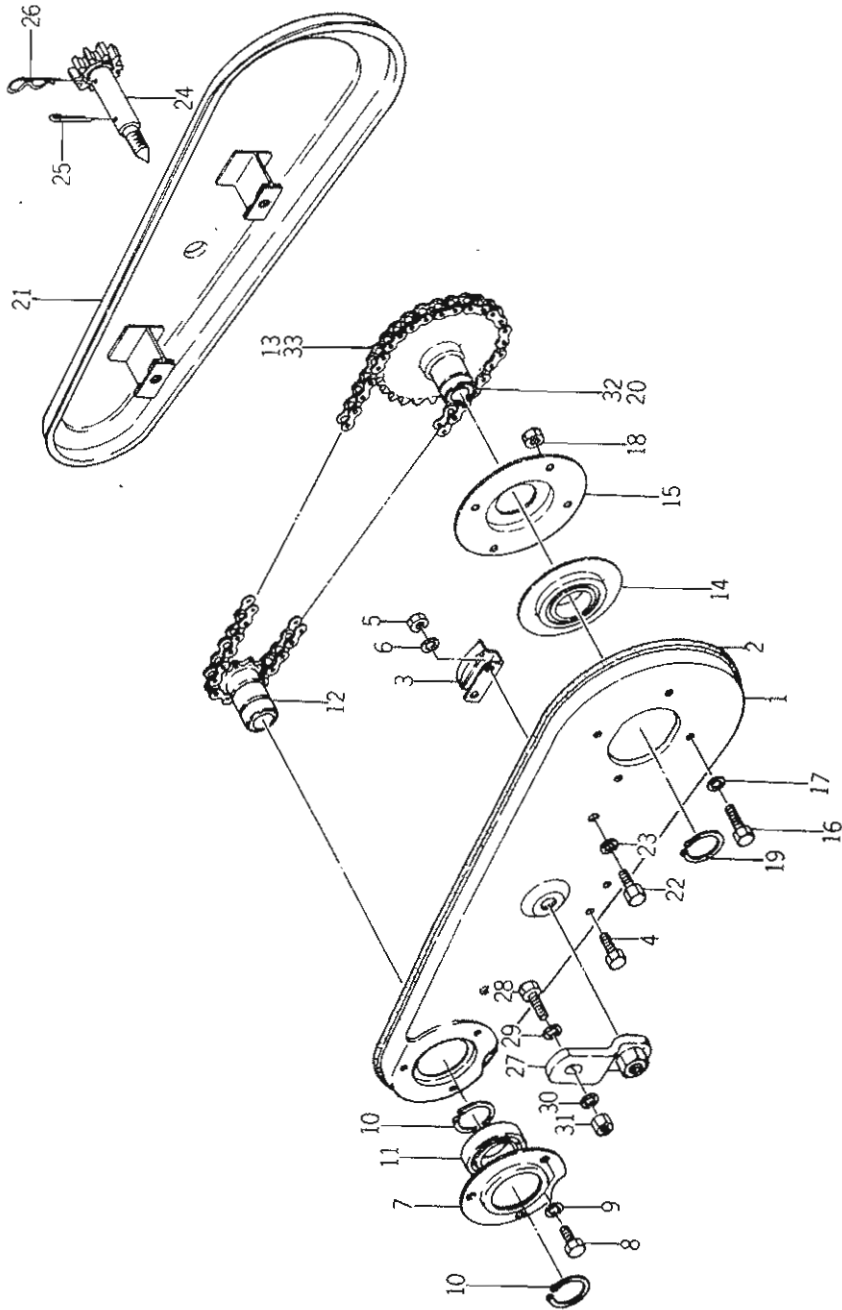

Ref No. Réf N°.	Parts No. Pièces N°.	Description Désignation	Model & Q'ty Modél & Quant			Remarks Remarques
			Ks 650	Ks 650D	Ks 650E	
16- 0-1	1365-070-2100-0	CASE, CHAIN ASSY Carter ensemble	1	1		
16- 1	1365-701-1000-0	·CASE, COUNTER CHAIN Carter de chaîne	1	1		
16- 2	1352-701-0010-0	·PACKING/RUBBER Joint caoutchouc	1	1		
16- 3	1352-701-0020-0	·GUIDE, CHAIN Guide chaîne	1	1		
16- 4	V20046-060100	·BOLT/M6×10 8T Vis	2	2		
16- 5	V30026-000600	·NUT/M6 Ecroû	2	2		
16- 6	V40126-000600	·WASHER, SP/M6 Rondelle frein	2	2		
16- 7	1352-701-0080-2	·GUIDE, BEARING Palier primaire	1	1		
16- 8	V20026-060120	·BOLT/M6×12 Vis	3	3		
16- 9	V40116-000600	·WASHER, SP/M6 Rondelle frein	3	3		
16-10	V70414-003000	·RING, SNAP/30 Collet d'axe	2	2		
16-11	V60012-060060	·BEARING, RB/6006Z Roulement	1	1		
16-12	1365-701-0010-0	·SPROCKET/11T Pignon	1	1		
16-13	1340-701-0030-0	·CHAIN, ROLLER Chaîne	1	1		
16-14	1340-701-3000-0	·METAL, CHAIN CASE B Palier secondaire	1	1		
16-15	1340-701-0040-0	·GUIDE, METAL Flasque de palier	1	1		
16-16	V20026-060120	·BOLT/M6×12 Vis	4	4		
16-17	V40116-000600	·WASHER, SP/M6 Rondelle frein	4	4		
16-18	V30026-000600	·NUT/M6 Ecroû	4	4		
16-19	V70414-003000	·RING, SNAP/C 30 Collet d'axe	1	1		
16-20	1365-701-0020-0	·SPROCKET/20T Pignon	1	1		
16-21	1365-701-2000-0	·COVER, CHAIN CASE Couvercle de carter	1	1		
16-22	V20126-080160	·BOLT/M8×16 Vis	2	2		
16-23	V40126-000800	·WASHER, SP/M8 Rondelle frein	2	2		
16-24	1352-701-5000-0	·KNOB, SET Bouton de fermeture	1	1		
16-25	V50015-300280	·PIN, SPLIT/3×28 Goupille fendue	1	1		
16-26	1352-701-0070-0	·PIN, HAIR Attache beta	1	1		
16-27	1352-701-4001-0	HOLDER, CHAIN CASE Patte de fixation	1	1		
16-28	V20126-100250	BOLT/M10×25 Vis	1	1		
16-29	V41326-001000	WASHER, PL/M10 Rondelle	2	2		
16-30	V40116-001000	WASHER, SP/M10 Rondelle frein	1	1		
16-31	V30026-001000	NUT/M10 Ecroû	1	1		
16-32	1365-701-0030-0	SPROCKET/15T Pignon	1	1		★
16-33	1365-701-0040-0	CHAIN, ROLLER Chaîne	1	1		★

Fig. 17

ROTARY CHAIN CASE  
Transmission de rotobineuse

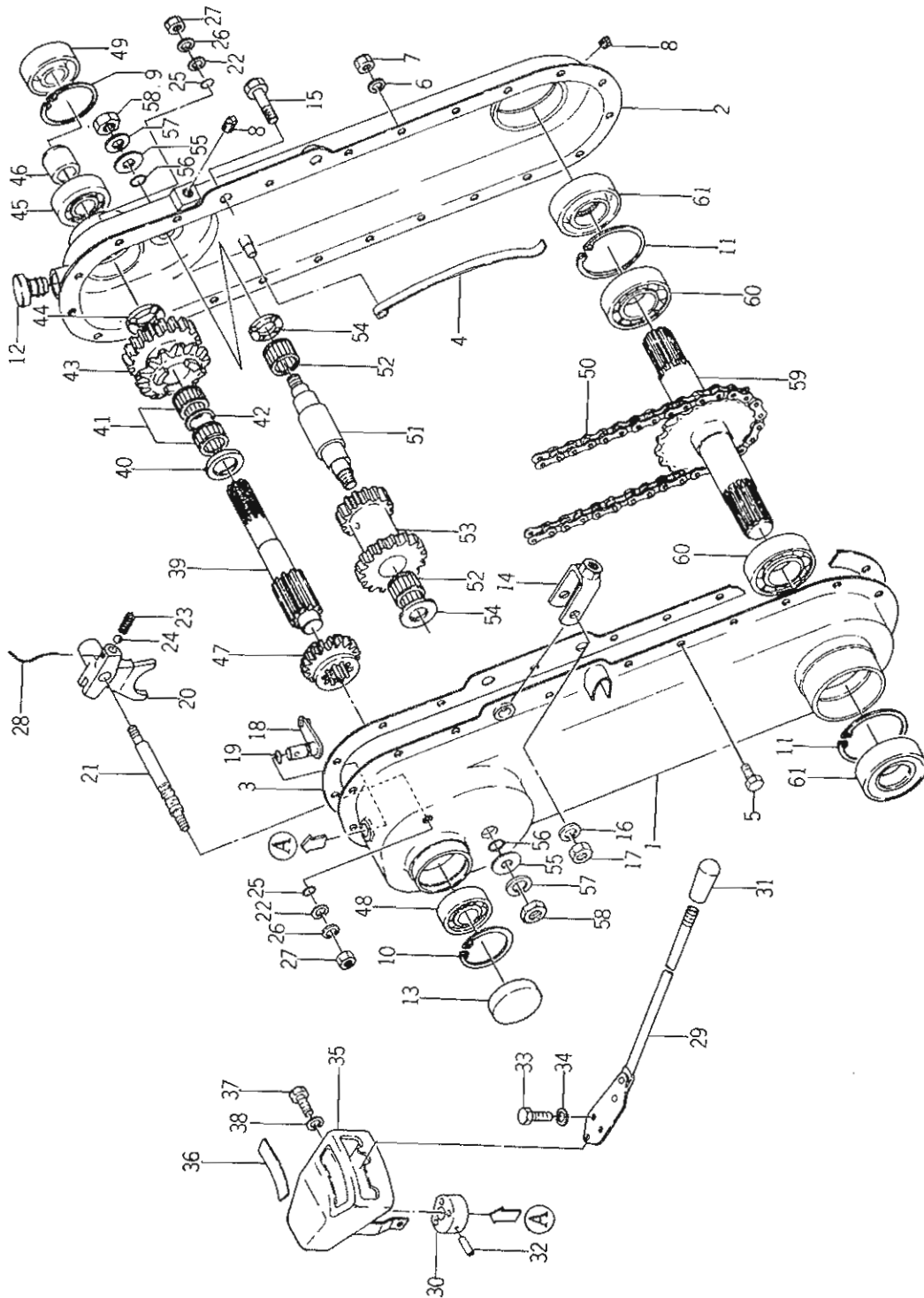

Ref No. Réf N°.	Parts No. Pièces N°.	Description Désignation	Model & Q'ty Modél & Quant			Remarks Remarques
			K S 650	K S 650D	K S 650E	
17- 1	1365-706-1000-1	CASE, ROTARY CHAIN LH Demi carter G.	1	1		
17- 2	1365-706-2000-1	CASE, ROTARY CHAIN RH Demi carter D.	1	1		
17- 3	1365-706-0010-0	PACKING, CHAIN CASE Joint de carter	1	1		
17- 4	1365-706-0020-0	TENSIONER Lingvet tendeur	1	1		
17- 5	V20026-060120	BOLT/M6 × 12 Vis	22	22		
17- 6	V40116-000600	WASHER, SP/M6 Rondelle frein	22	22		
17- 7	V30026-000600	NUT/M6 Ecrou	22	22		
17- 8	1326-706-0020-0	PLUG, DRAIN/PT 1/8 Bouchon de vidange	2	2		
17- 9	V70514-005200	RING, SNAP/C 52 Collet d'axe	1	1		
17-10	V70514-004700	RING, SNAP/C 47 Collet d'axe	1	1		
17-11	V70514-006200	RING, SNAP/C 62 Collet d'axe	2	2		
17-12	1340-216-0040-0	CAP, OIL/24 Bouchon	1			650R No. 1-4540
17-12a	1366-706-0010-0	CAP, OIL/23 Bouchon	1	1		{ 650R No. 4541- 650DR No. 1-
17-13	1340-706-0050-0	SEAL Opércule	1	1		
17-14	1337-706-3000-0	YOKE Chape	1	1		
17-15	V20126-100400	BOLT/M10 × 40 Vis	1	1		
17-16	V40116-001000	WASHER, SP/M10 Rondelle frein	1	1		
17-17	V30026-001000	NUT/M10 Ecrou	1	1		
17-18	1365-710-1000-0	ARM, SHIFT Selecteur	1			650R No. 1-8520
17-18a	1365-710-1001-0	ARM, SHIFT Selecteur	1	1		{ 650R No. 8521- 650DR No. 1-
17-19	V72010-190090	O-RING/P9 Joint torique	1	1		
17-20	1365-710-0010-0	SHIFTER, ROTARY Fourchette	1	1		
17-21	1365-710-0020-0	STAY, SHIFTER Axe de fourchette	1	1		
17-22	1365-710-0030-0	COLLAR/8 × 16 × 5 Collier	2	2		
17-23	1302-225-0030-0	SPRING, SHIFTER Ressort	1	1		
17-24	V68010-000100	BALL, STEEL Bille	1	1		
17-25	V72010-190080	O-RING/P8 Joint torique	2	2		
17-26	V40116-000800	WASHER, SP/M8 Rondelle frein	2	2		
17-27	V30026-000800	NUT/M8 Ecrou	2	2		
17-28	V59013-160300	WIRE/1.6 × 30 Fil	1	1		
17-29	1365-710-2000-0	LEVER, SHIFT Lever	1	1		
17-30	1365-710-0040-0	BOSS Bossage	1			650R No. 1-8520
17-30a	1365-710-0041-0	BOSS Bossage	1	1		{ 650R No. 8521- 650DR No. 1-
17-31	4106-105-3030-0	GRIP Poignée	1	1		
17-32	V58014-050320	PIN, SPRING/5 × 32 Goupille elastique	1	1		
17-33	V20026-060100	BOLT/M6 × 10 Vis	3	3		
17-34	V40116-000600	WASHER, SP/M6 Rondelle frein	3	3		
17-35	1365-710-3000-0	GUIDE, SHIFT LEVER Guide de commande	1	1		

Fig. 17

ROTARY CHAIN CASE

Transmission de rotobineuse

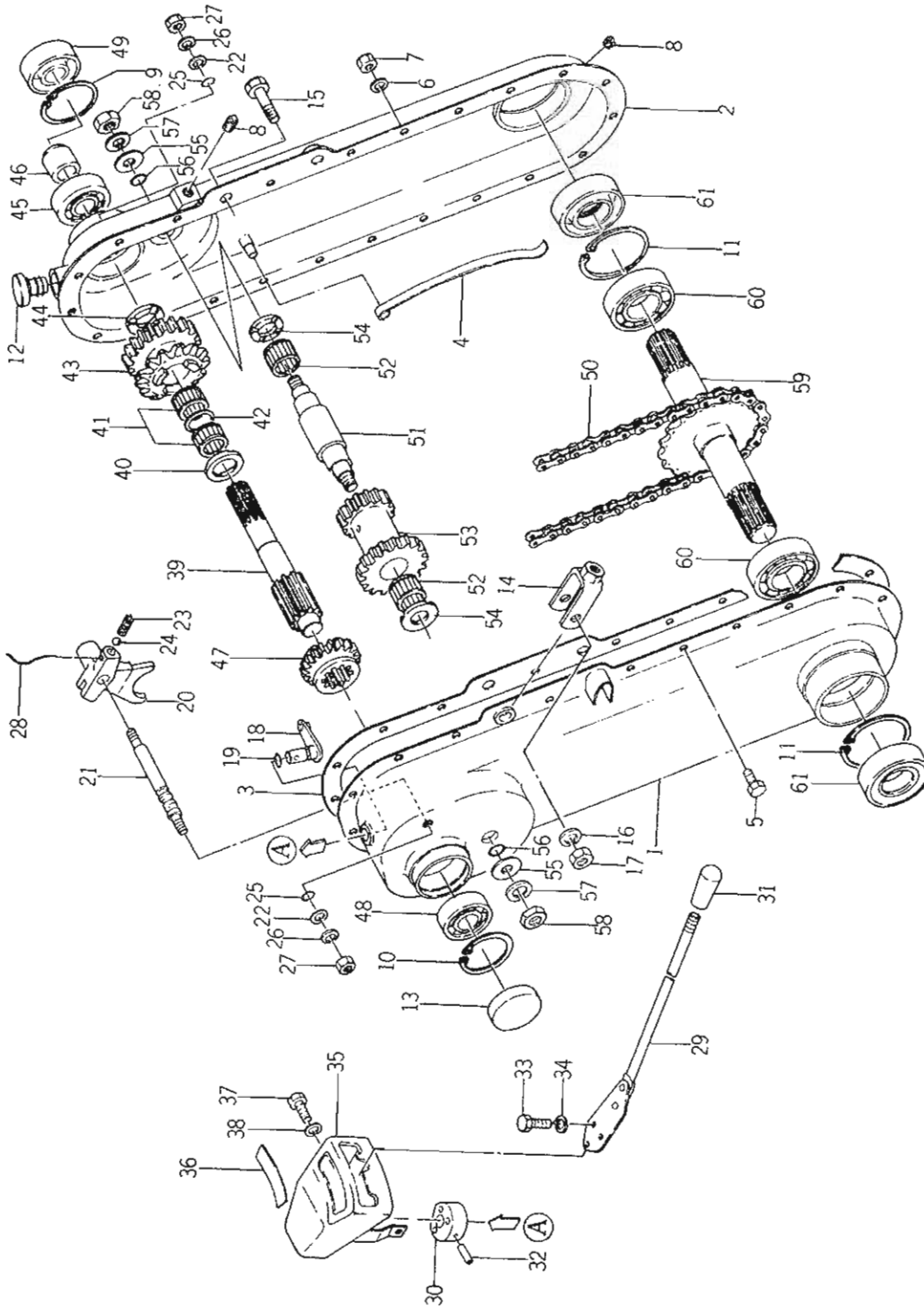

Ref No. Réf N°.	Parts No. Pièces N°.	Description Désignation	Model & Q'ty Modél & Quant			Remarks Remarques
			K S 650	K S 650D	K S 650E	
17-36	1365-956-0020-0	MARK, ROTARY SHIFT Repere	1	1		
17-37	V20126-080150	BOLT/M8×15 Vis	2	2		} 650R No. 1-6470
17-38	V40116-000800	WASHER, SP/M8 Rondelle frein	2	2		
17-39	1365-707-0010-0	SHAFT, TOP Arbre supérieur	1	1		
17-40	1365-707-0040-0	COLLAR/23×34×3 Collier	1	1		
17-41	1365-707-0070-0	BEARING, NR/KT233016 Roulement	2	2		
17-42	1365-707-0080-0	COLLAR/23×28×9 Collier	1	1		
17-43	1365-707-0020-0	SPROCKET/13T Pignon	1	1		
17-44	1365-707-0030-0	COLLAR/20×34×3 Collier	1	1		
17-45	V60011-063040	BEARING, RB/6304 Roulement	1	1		
17-46	1352-217-0040-0	BUSH, SEAL Cousinnet	1	1		
17-47	1365-707-0050-0	GEAR, SHIFT/17T Pignon	1	1		
17-48	V60011-062040	BEARING, RB/6204 Roulement	1	1		
17-49	V74112-552100	SEAL, OIL/SB255210 Bague d'étanchéité	1	1		
17-50	1365-707-0060-0	CHAIN, ROLLER Chaîne	1	1		
17-51	1365-708-0010-0	SHAFT, COUNTER Arbre intermédiaire	1	1		
17-52	1365-708-0040-0	BEARING, NR/KT222720 Roulement	2	2		
17-53	1365-708-0020-0	GEAR, COUNTER/20-15T Pignon	1	1		
17-54	1365-708-0030-0	COLLAR/16×34×3 Collier	2	2		
17-55	1365-708-0050-0	COLLAR/16×28×6 Collier	2	2		
17-56	V72010-240160	O-RING/P16 Collet d'axe	2	2		
17-57	V40116-001200	WASHER, SP/M12 Rondelle frein	2	2		
17-58	V30026-001200	NUT/M12 Écrou	2	2		
17-59	1365-709-1000-0	SHAFT, ROTARY Arbre de fraises	1	1		
17-60	V60011-062060	BEARING, RB/6206 Roulement	2	2		
17-61	1365-709-0010-0	SEAL, OIL Bague d'étanchéité	2	2		

Fig. 18

ROTARY FRAME  
Enveloppe de rotobineuses

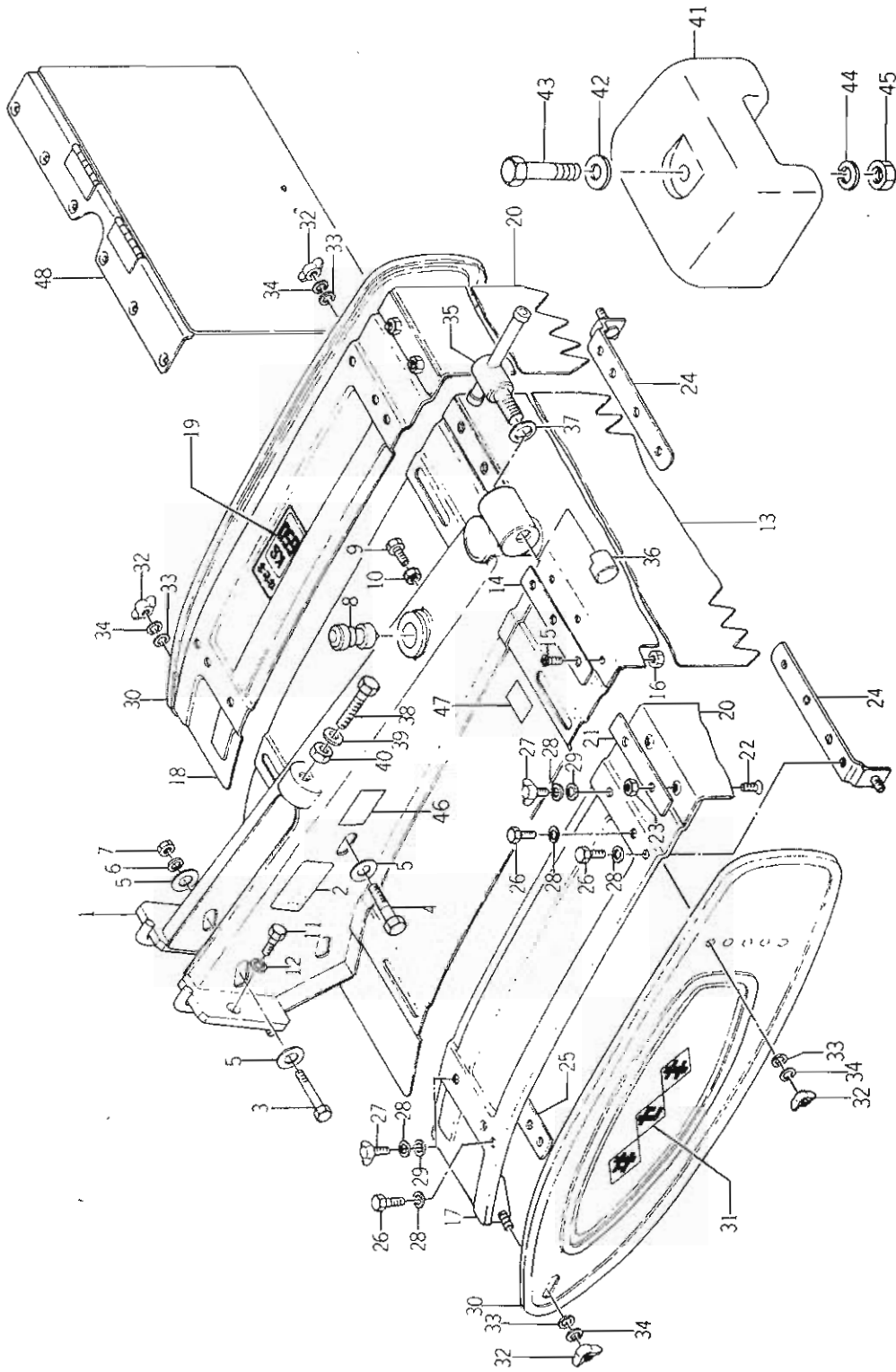



Ref No. Réf N°.	Parts No. Pièces N°.	Description Désignation	Model & Q'ty Modél & Quant			Remarks Remarques
			KS 650	KS 650D	KS 650E	
18- 1	1365-721-1000-1	FRAME, ROTARY Chassis	1	1		
18- 2	1349-956-0060-0	MARK, ROTARY OIL Etiquette	1	1		
18- 3	V20126-101300	BOLT/M10×130 Vis	2	2		
18- 4	V20126-101250	BOLT/M10×125 Vis	1	1		
18- 5	1340-101-1080-0	WASHER Rondelle	6	6		
18- 6	V40116-001000	WASHER, SP/M10 Rondelle frein	3	3		
18- 7	V30026-001000	NUT/M10 Erou	3	3		
18- 8	1323-721-0030-0	CAP, PIPE Bouchon	1			
18- 9	W20126-140550	BOLT/M14×55 S=55 Vis	1	1		
18-10	V30526-001400	NUT/M14 Erou	1	1		
18-11	V20126-120750	BOLT/M12×75 Vis	2	2		
18-12	V40116-001200	WASHER, SP/M12 Rondelle frein	2	2		
18-13	1365-721-0010-0	GUARD, MUD Bavette	1	1		
18-14	1365-721-0020-0	PLATE, SET Barrette	2	2		650R No. 1-14970
18-15	V11216-500100	SCREW/M5×10 Vis	6	6		
18-16	V30026-000500	NUT/M5 Erou	6	6		
18-17	1352-721-2000-1	COVER, ADJ LH Rallonge réglable G	1	1		
18-18	1352-721-3000-1	COVER, ADJ RH Rallonge réglable D.	1	1		
18-19	1365-956-0010-0	MARK, ROTARY MODEL Etiquette	1	1		
18-20	1337-721-0060-0	GUARD, MUD SUB Bavette aux.	2	2		
18-21	1337-721-0070-0	PLATE, SET SUB Bavette aux.	2	2		
18-22	V11216-500100	SCREW/M5×10 Vis	4	4		
18-23	V30026-000500	NUT/M5 Erou	4	4		
18-24	1352-721-4000-0	PLATE, COVER SET A Bride de bavolet	2	2		
18-25	1352-721-5000-0	PLATE, COVER SET B Bride de bavolet	2	2		
18-26	V20126-080160	BOLT/M8×16 Vis	4	4		
18-27	V27016-080180	BOLT, WING/M8×18 Vis a oreilles	8	8		
18-28	V40116-000800	WASHER, SP/M8 Rondelle frein	12	12		
18-29	V41326-000800	WASHER, PL/M8 Rondelle	8	8		
18-30	1352-721-6000-1	COVER, ROTARY SIDE Bavolet	2	2		
18-31	1326-953-0070-0	MARK, ISEKI Etiquette	2	2		
18-32	V37116-000800	NUT, WING/M8 Erou a oreilles	4	4		
18-33	V41316-000800	WASHER, PL/M8 Rondelle	4	4		
18-34	V40116-000800	WASHER, SP/M8 Rondelle frein	4	4		
18-35	1338-722-1000-0	HANDLE, SLEEVE SET Vis serre-jambe	1	1		
18-36	1326-721-0010-0	PLATE, SLEEVE CLAMP Coin de blocage	1	1		
18-37	V41316-001600	WASHER, PL/M16 Rondelle	1	1		
18-38	V20126-100630	BOLT/M10×63 S=43 Vis	1	1		

Fig. 18 ROTARY FRAME  
 Enveloppe de rotobineuses

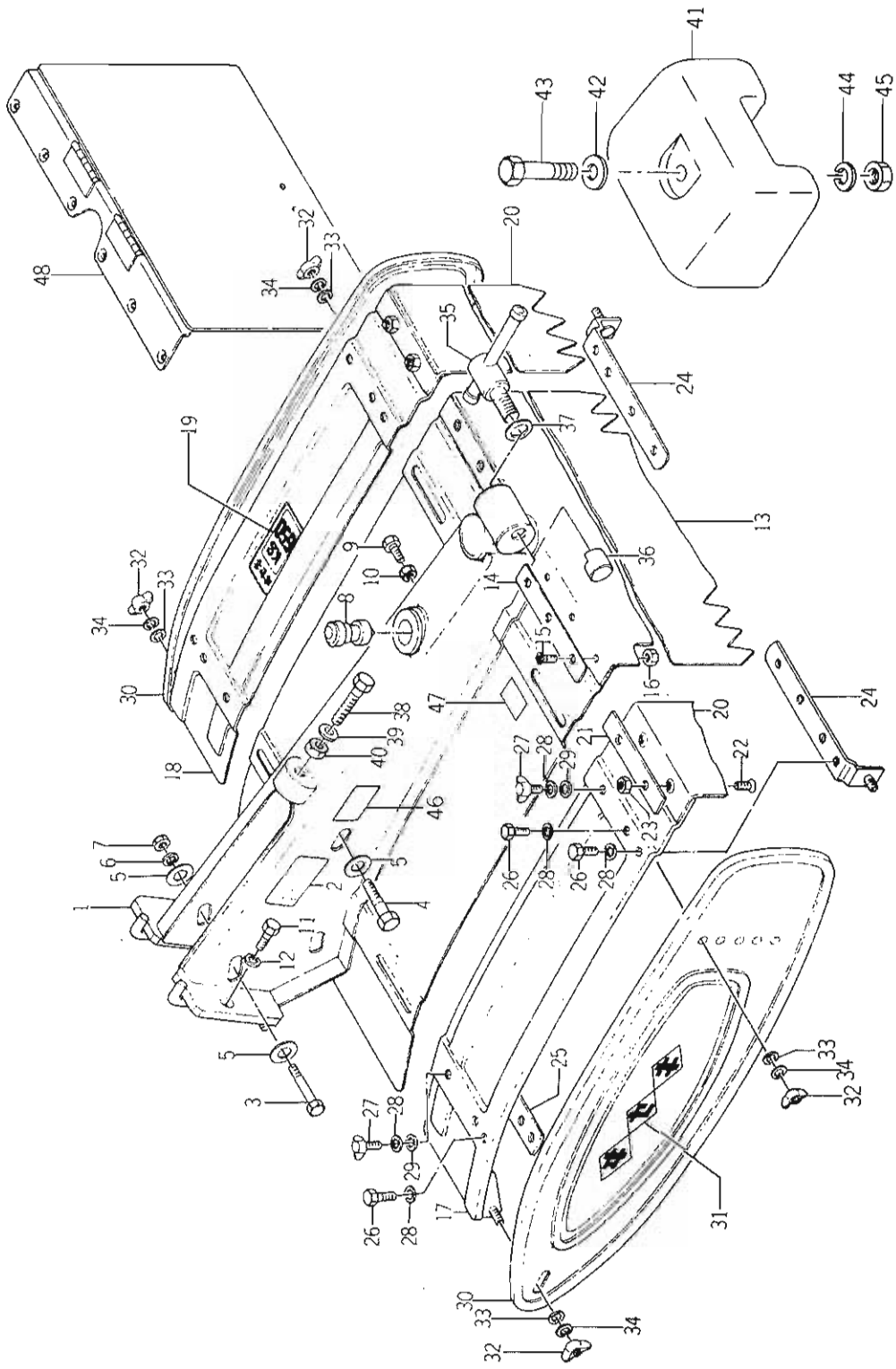

Ref No. Réf N°.	Parts No. Pièces N°.	Description Désignation	Model & Q'ty Model & Quant			Remarks Remarques
			KS 650	KS 650D	KS 650E	
18-39	V41316-001000	WASHER, PL/M10 Rondelle	1	1		
18-40	V30226-001000	NUT/M10 Erou	1	1		
18-41	1371-931-0010-0	WEIGHT, ROTARY Masse		1		} DE, DHE ... *
18-42	1332-708-0030-0	WASHER, COUPLING Rondelle		1		
18-43	V20126-101400	BOLT/M10×14 Vis		1		
18-44	V40116-001000	WASHER, SP/M10 Rondelle frein		1		
18-45	V30026-001000	NUT/M10 Erou		1		
18-46	1352-903-0030-0	MARK, BACKPROOF Etiquette	1	1		650R No. 6471-
18-47	1376-902-0060-0	MARK, CAUTION Etiquette	1	1		
18-48	1365-721-2000-0	GUARD, R. Volet AR	1	1		650R No. 14971-

Fig. 19

ROTARY PIPE  
Fraise

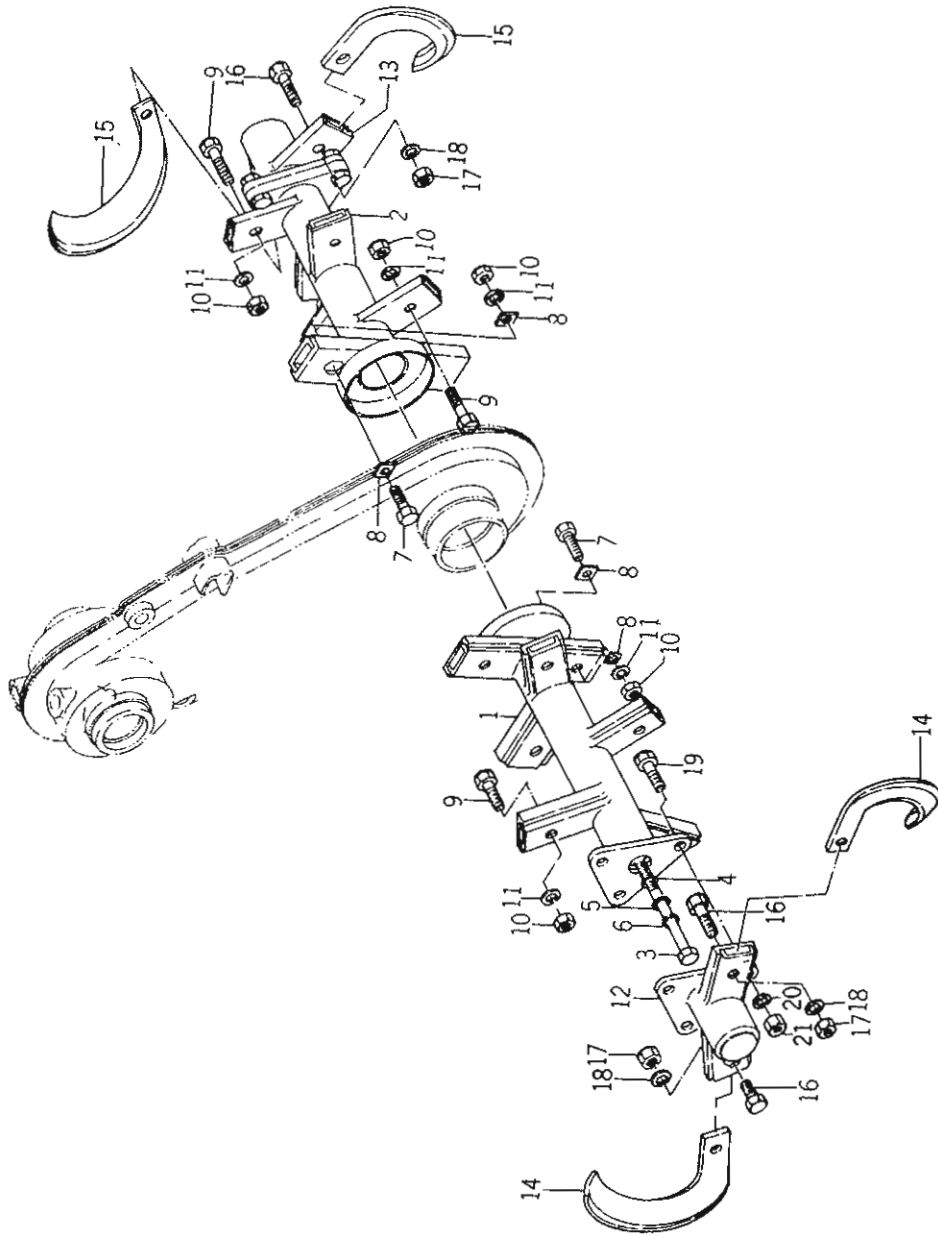

Ref No. Réf N°.	Parts No. Pièces N°.	Description Désignation	Model & Q'ty Modél & Quant			Remarks Remarques
			KS 650	KS 650D	KS 650E	
19- 1	1365-716-1000-0	PIPE, ROTARY LH Tube de fraise G.	1	1		
19- 2	1365-716-2000-0	PIPE, ROTARY RH Tube de fraise D.	1	1		
19- 3	V20126-121400	BOLT/M12×140 Vis	2	2		
19- 4	V72010-240120	O-RING/P12 Joint torique	2	2		
19- 5	V41116-001200	WASHER, PL/M12 Rondelle	2	2		
19- 6	V40116-001200	WASHER, SP/M12 Rondelle frein	2	2		
19- 7	1323-071-7000-0	BOLT, BLADE SET A Vis	4	4		Included 10,11 Compris 10,11
19- 8	1301-716-0020-0	WASHER Rondelle	8	8		
19- 9	1323-071-7100-0	BOLT, BLADE SET B Vis	10	10		Included 10,11 Compris 10,11
19-10	V30026-001000	NUT/M10 Ecrou	14	14		
19-11	V40126-001000	WASHER, SP/M10 Rondelle frein	14	14		
19-12	1365-717-1000-0	PIPE, SUB ROTARY LH Rallonge G.	1	1		★
19-13	1365-717-2000-0	PIPE, SUB ROTARY RH Rallonge D.	1	1		★
19-14	1365-716-0030-0	BLADE, CARRIED LH/C130 Couteau G.	2	2		★
19-15	1365-716-0040-0	BLADE, CARRIED RH/C130 Couteau D.	2	2		★
19-16	1323-071-7100-0	BOLT, BLADE SET B Vis	4	4		★
19-17	V30026-001000	NUT/M10 Ecrou	4	4		★
19-18	V40126-001000	WASHER, SP/M10 Rondelle frein	4	4		★
19-19	V20126-080250	BOLT/M8×25 Vis	6	6		★
19-20	V40126-000800	WASHER, SP/M8 Rondelle frein	6	6		★
19-21	V30026-000800	NUT/M8 Ecrou	6	6		★

KS650D ... standard parts

Fig. 20

REAR WHEEL

Roue de profondeur

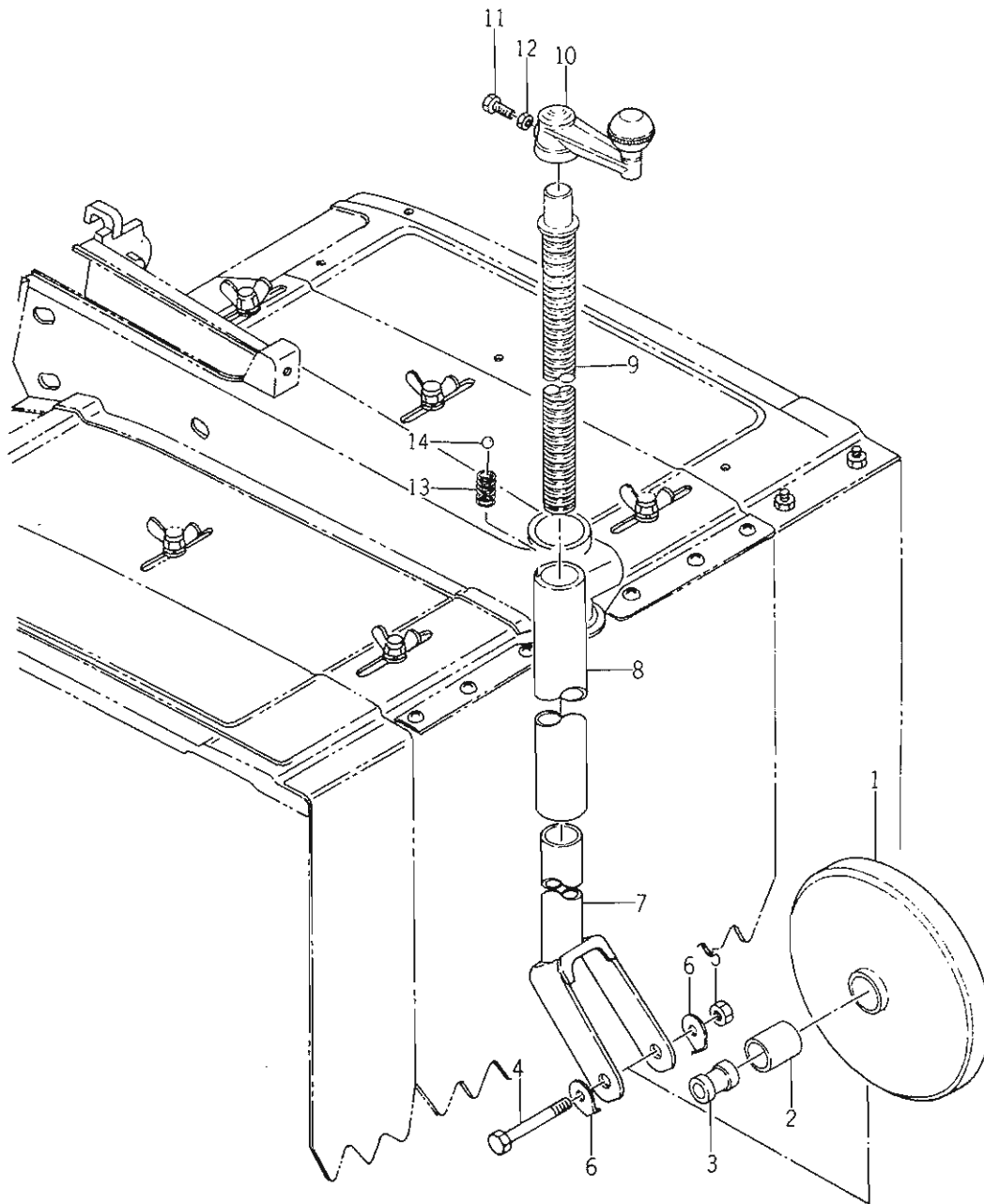

Ref No. Réf N°.	Parts No. Pièces N°.	Description Désignation	Model & Q'ty Modél & Quant			Remarks Remarques
			KS 650	KS 650D	KS 650E	
20- 1	1322-726-0010-0	WHEEL, GAUGE Roue AR	1	1		
20- 2	1322-726-0020-0	BUSH, GAUGE WHEEL Manchon	1	1		
20- 3	1322-726-0030-0	COLLAR, GAUGE WHEEL SHAFT Collier	1	1		
20- 4	1340-726-0011-0	PIN, GAUGE WHEEL Axe de roue AR	1	1		
20- 5	V30026-001200	NUT/M12 Erou	1	1		
20- 6	1322-726-0050-0	WASHER, LOCK Rondelle	2	2		
20- 7	1365-726-1000-0	FORK, GAUGE WHEEL Fourche	1	1		
20- 8	1324-726-1000-0	SLEEVE, GAUGE WHEEL Jambe	1	1		
20- 9	1308-726-3000-0	SCREW, GAUGE WHEEL ADJ Vis de profondeur	1	1		
20-10	1326-726-4000-0	HANDLE, GAUGE WHEEL ADJ Manivelle	1	1		
20-11	V20126-080240	BOLT/M8 x 24 Vis	1	1		
20-12	V30526-000800	NUT/M8 Erou	1	1		
20-13	1302-726-0060-0	SPRING, GAUGE WHEEL LOCK Ressort	1	1		
20-14	V68010-000080	BALL, STEEL Bille	1	1		

Fig. 21 TOOLS  
Outils

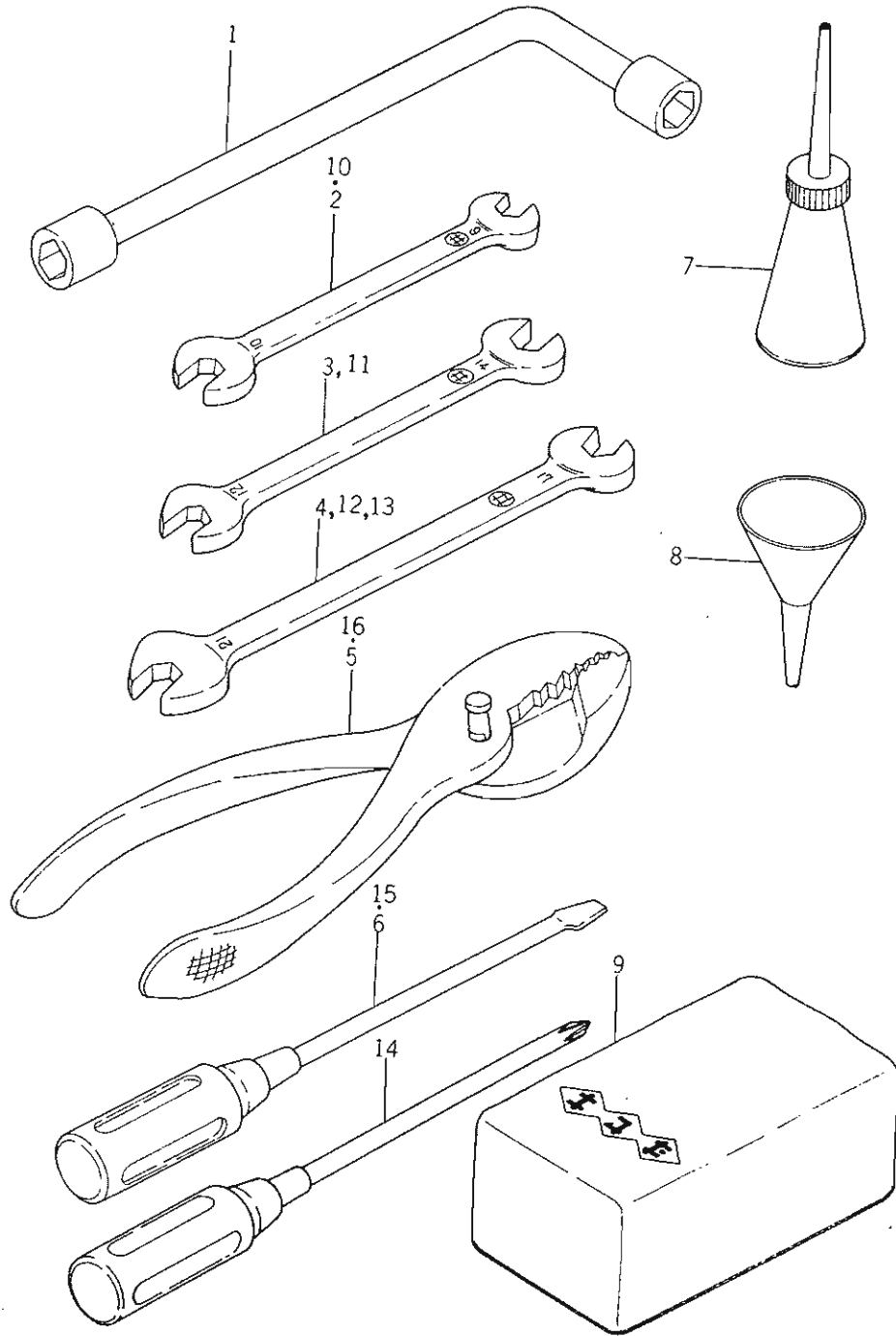



Ref No. Réf N°.	Parts No. Pièces N°.	Description Désignation	Model & Q'ty Modél & Quant			Remarks Remarques
			KS 650	KS 650D	KS 650E	
21- 1	1305-906-0010-0	WRENCH, L-TYPE Cle a pipe	1	1	1	
21- 2	V92055-090100	SPANNER/9-10 Cle plate	1	1	1	No. 1-12770 DNo. 1-1300 ENo. 1-14970
21- 3	V92055-120140	SPANNER/12-14 Cle plate	1	1	1	No. 1-12770
21- 4	V92055-170210	SPANNER/17-21 Cle plate	1	1	1	No. 1-12770 DNo. 1-1300 ENo. 1-14970
21- 5	V93615-001500	PLIERS/150 Pinces	1	1	1	No. 1-12770
21- 6	V94010-061000	SCREWDRIVER/6 x 100 Tournevis	1	1	1	No. 1-12770 DNo. 1-1300 ENo. 1-14970
21- 7	1352-906-0010-0	OILER Burette	1	1	1	
21- 8	1352-906-0020-0	FUNNEL, OIL FILLER Entonnoir	1	1	1	
21- 9	1352-906-0030-0	COVER Housse	1			
21-10	V92055-080100	SPANNER Cle plate	1			No. 12771-
21-11	V92055-120140	SPANNER Cle plate	1			
21-12	V92055-130170	SPANNER Cle plate	1			
21-13	V92055-190220	SPANNER Cle plate	1			Ⓣ
21-14	V94515-061000	SCREWDRIVER, CROSS Tournevis	1	1	1	
21-15	V94019-061000	SCREWDRIVER Tournevis				No. 12771-
21-16	V93625-001500	PLIERS/150 Pinces	1			

Fig. 22 ROTARY BELT DRIVE  
 Courroie intermediaire

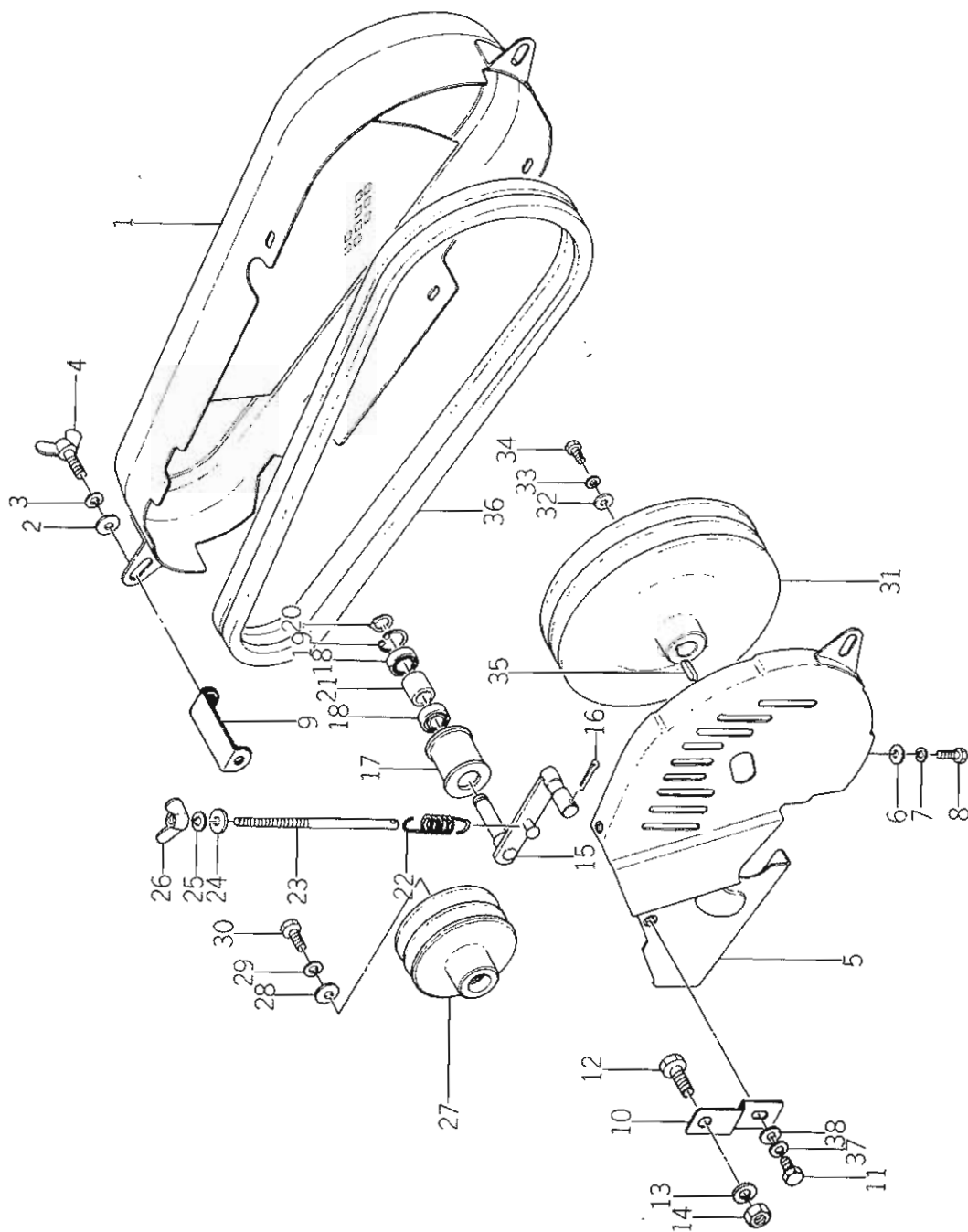

Ref N <sup>o</sup> .	Parts No.	Description	Model & Q'ty				Remarks
			Modél & Quant				
Ref N <sup>o</sup> .	Pièces No.	Désignation	F40	F60	F80	F100	Remarques
22- 1	1365-751-2001-0	COVER, BELT A Carter de courroies	1	1	1	1	★
22- 2	V41316-000800	WASHER, PL/M8 Rondelle	1	1	1	1	★
22- 3	V40116-000800	WASHER, SP/M8 Rondelle frein	1	1	1	1	★
22- 4	V27116-080200	BOLT, WING/M8 × 20 Vis a oreilles	1	1	1	1	★
22- 5	1365-751-2100-0	COVER, BELT B Carter de courroies	1	1	1	1	★
22- 6	V41316-000600	WASHER, PL/M6 Rondelle	3	3	3	3	★
22- 7	V40116-000600	WASHER, SP/M6 Rondelle frein	3	3	3	3	★
22- 8	V20026-060120	BOLT/M6 × 12 Vis	3	3	3	3	★
22- 9	1365-751-2400-0	STAY, COVER C Support	1	1	1	1	★
22-10	1365-751-0010-0	STAY, COVER B Support	1	1	1	1	★
22-11	V20126-080160	BOLT/M8 × 16 Vis	1	1	1	1	★
22-12	V20126-100200	BOLT/M10 × 20 Vis	1	1	1	1	★
22-13	V40116-001000	WASHER, SP/M10 Rondelle frein	1	1	1	1	★
22-14	V30026-001000	NUT/M10 Ecrou	1	1	1	1	★
22-15	1365-751-2300-0	ARM, TENSION Tirant	1	1	1	1	★
22-16	V50015-300250	PIN, SPLIT Goupille fendue	1	1	1	1	★
22-17	1329-202-0011-0	PULLEY, TENSION/40-43 Galet tendeur	1	1	1	1	★
22-18	V60014-062010	BEARING, RB/6201RS Roulement	2	2	2	2	★
22-19	V70514-003200	RING, SNAP/C 32 Collet d'axe	1	1	1	1	★
22-20	V70414-001200	RING, SNAP/C 12 Collet d'axe	1	1	1	1	★
22-21	1329-202-0030-0	COLLAR, TENSION Collier	1	1	1	1	★
22-22	1325-401-0090-0	SPRING, MAIN CLUTCH Ressort	1	1	1	1	★
22-23	1365-751-0020-0	BOLT, TENSION Vis	1	1	1	1	★
22-24	V41316-000800	WASHER, PL/M8 Rondelle	2	2	2	2	★
22-25	V40116-000800	WASHER, SP/M8 Rondelle frein	2	2	2	2	★
22-26	V37116-000800	NUT, WING/M8 Ecrou a oreilles	1	1	1	1	★
22-27	1365-751-0030-0	PULLEY, V/80 Rea	1	1	1	1	★
22-28	1324-205-0020-0	WASHER Rondelle	1	1	1	1	★
22-29	V40116-000800	WASHER, SP/M8 Rondelle frein	1	1	1	1	★
22-30	V20126-080160	BOLT/M8 × 16 Vis	1	1	1	1	★
22-31	1365-751-0040-0	PULLEY, V/180 Rea	1	1	1	1	★
22-32	1305-701-0060-0	WASHER Rondelle	1	1	1	1	★
22-33	V40116-000600	WASHER, SP/M6 Rondelle frein	1	1	1	1	★
22-34	V20026-060160	BOLT/M6 × 16 Vis	1	1	1	1	★
22-35	1329-917-0020-0	KEY, PULLEY Clavette	1	1	1	1	★
22-36	V81720-004800	BELT, V/SB48 Courroie de reas	2	2	2	2	★
22-37	V40116-000800	WASHER, SP/M8 Rondelle frein	1	1	1	1	★
22-38	V41316-000800	WASHER, PL/M8 Rondelle	1	1	1	1	★

Fig. 23

BACKPROOF DEVICE

Mechanisme de securite

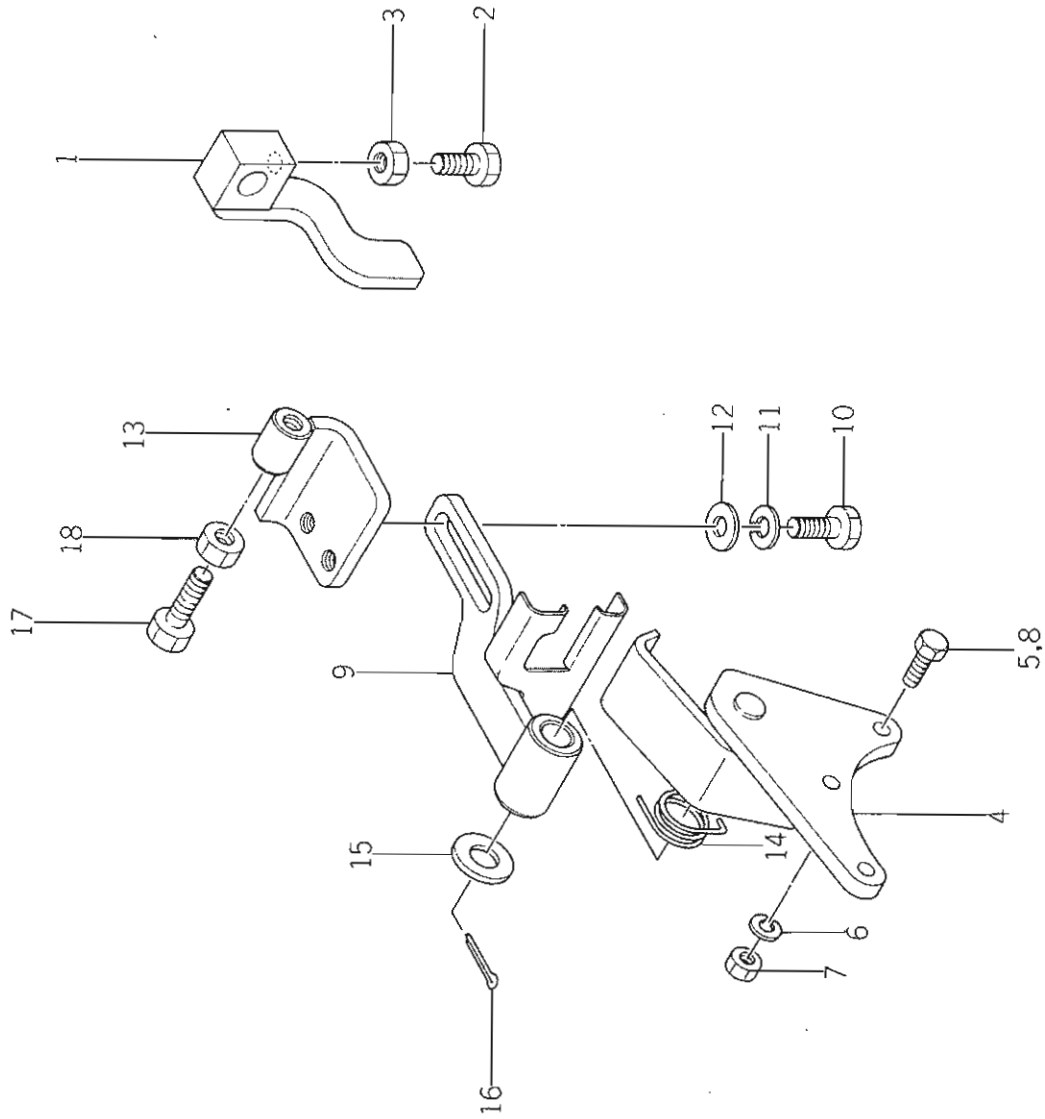

Ref N <sup>o</sup> .	Parts No.	Description	Model & Q'ty				Remarks
			Modél & Quant				
Ref N <sup>o</sup> .	Pièces No.	Désignation	F40	F60	F80	F100	Remarques
23- 0-1	1365-762-0000-0	DEVICE, BACKPROOF ASSY Mecanisme de securite	1	1	1	1	★
23- 1	1352-712-1000-0	·ARM, BACKPROOF Bras	1	1	1	1	★
23- 2	V20126-080200	·BOLT/M8 × 20 Vis	1	1	1	1	★
23- 3	V30226-000800	·NUT/M8 Ecrou	1	1	1	1	★
23- 4	1352-712-2000-0	·BRACKET, LEVER Support	1	1	1	1	★
23- 5	V20026-060200	·BOLT/M6 × 20 Vis	2	2	2	2	★
23- 6	V40116-000600	·WASHER, SP/M6 Rondelle frein	3	3	3	3	★
23- 7	V30026-000600	·NUT/M6 Ecrou	1	1	1	1	★
23- 8	V20026-060250	·BOLT/M6 × 25 Vis	1	1	1	1	★
23- 9	1365-762-2000-0	·LEVER, BACKPROOF A Lever	1	1	1	1	★
23-10	V20126-080200	·BOLT/M8 × 20 Vis	2	2	2	2	★
23-11	V40116-000800	·WASHER, SP/M8 Rondelle frein	2	2	2	2	★
23-12	V41316-000800	·WASHER, PL/M8 Rondelle	2	2	2	2	★
23-13	1365-762-2100-0	·LEVER, BACKPROOF B Lever	1	1	1	1	★
23-14	1352-712-0010-0	·SPRING, TORQUE Ressort	1	1	1	1	★
23-15	V41316-001200	·WASHER, PL/M12 Rondelle	1	1	1	1	★
23-16	V50016-300200	·PIN, SPLIT/3 × 20 Goupille fendue	1	1	1	1	★
23-17	V20126-080350	·BOLT/M8 × 35 Vis	1	1	1	1	★
23-18	V30226-000800	·NUT/M8 Ecrou	1	1	1	1	★

Fig. 24

ROTARY CHAIN CASE

Transmission de rotobineuse

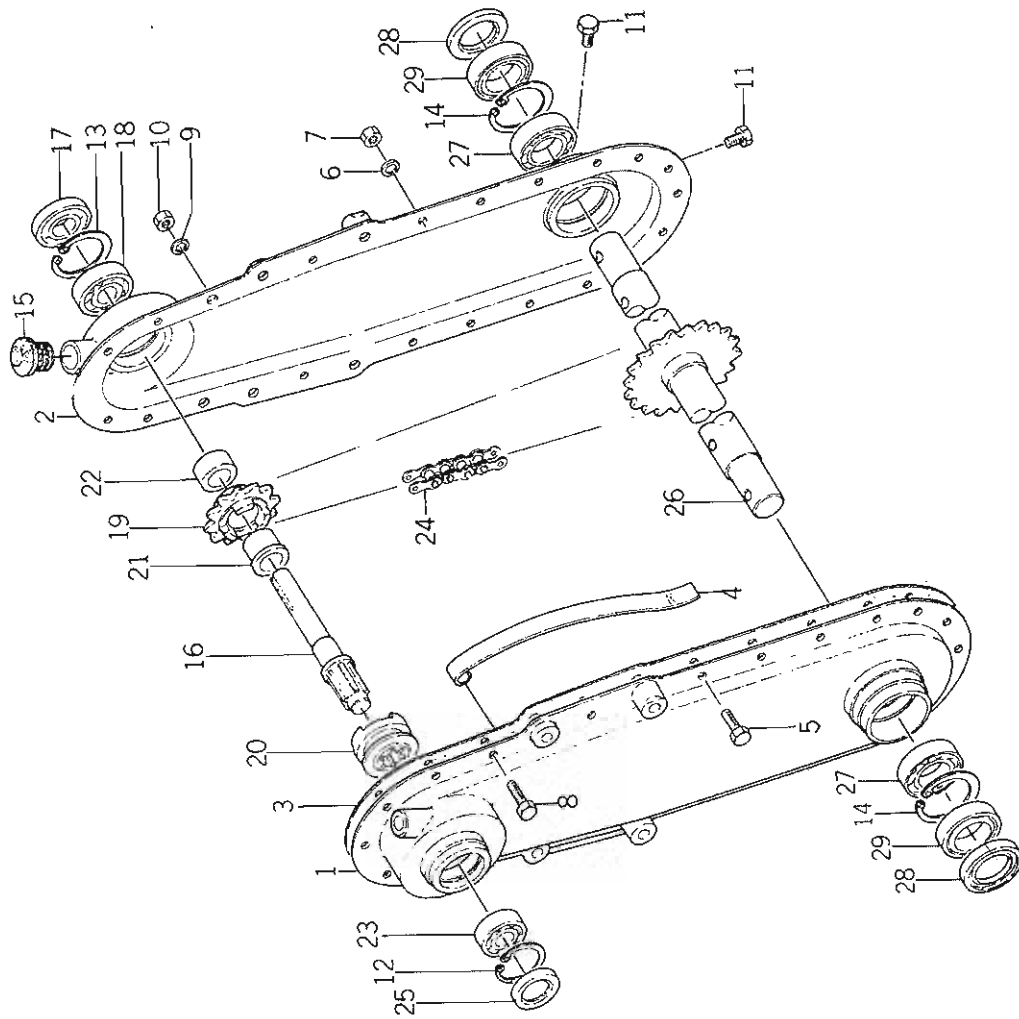

Ref No. Réf No.	Parts No. Pièces No.	Description Désignation	Model & Q'ty Modél & Quant				Remarks Remarques
			F 40	F 60	F 80	F 100	
24- 1	1349-706-1000-0	CASE, ROTARY CHAIN LH Carter de chaîne G.	1	1	1	1	★
24- 2	1349-706-2000-0	CASE, ROTARY CHAIN RH Carter de chaîne D.	1	1	1	1	★
24- 3	1349-706-0010-0	PACKING, CHAIN CASE Joint	1	1	1	1	★
24- 4	1337-706-0020-0	TENSIONER, CHAIN Tendeur	1	1	1	1	★
24- 5	V20026-060120	BOLT/M6×12 Vis	16	16	16	16	★
24- 6	V40116-000600	WASHER, SP/M6 Rondelle frein	16	16	16	16	★
24- 7	V30026-000600	NUT/M6 Ecrou	16	16	16	16	★
24- 8	V20126-080160	BOLT/M8×16 Vis	4	4	4	4	★
24- 9	V40116-000800	WASHER, SP/M8 Rondelle frein	4	4	4	4	★
24-10	V30026-000800	NUT/M8 Ecrou	4	4	4	4	★
24-11	1326-706-0020-0	PLUG, DRAIN Bouchon	2	2	2	2	★
24-12	V70514-004000	RING, SNAP/C 40 Collet d'axe	1	1	1	1	★
24-13	V70514-004700	RING, SNAP/C 47 Collet d'axe	1	1	1	1	★
24-14	V70514-005500	RING, SNAP/C 55 Collet d'axe	2	2	2	2	★
24-15	1366-706-0010-0	CAP, OIL/23 Bouchon	1	1	1	1	★
24-16	1337-708-0010-0	SHAFT, ROTARY TOP Arbre	1	1	1	1	★
24-17	V74012-047070	SEAL, OIL/SC20477 Bague d'étanchéité	1	1	1	1	★
24-18	V60011-062040	BEARING, RB/6204 Roulement	1	1	1	1	★
24-19	1349-708-0010-0	SPROCKET/12T Pignon	1	1	1	1	★
24-20	1337-708-0030-0	CLUTCH, ROTARY Embrayage	1	1	1	1	★
24-21	1337-708-0040-0	BUSH, SPROCKET Cousinet	1	1	1	1	★
24-22	1337-708-0050-0	COLLAR/21×30×9 Entretoise	1	1	1	1	★
24-23	V60011-062030	BEARING, RB/6203 Roulement	1	1	1	1	★
24-24	1337-708-0060-0	CHAIN, ROLLER Chaîne	1	1	1	1	★
24-25	1337-708-0070-0	COVER, METAL Couvercle	1	1	1	1	★
24-26	1349-709-1000-0	SHAFT, ROTARY Arbre de fraises	1	1	1	1	★
24-27	V60011-060060	BEARING, RB/6006 Roulement	2	2	2	2	★
24-28	V74213-055050	SEAL, OIL/VC30555 Bague d'étanchéité	2	2	2	2	★
24-29	V74413-055120	SEAL, OIL/TC305512 Bague d'étanchéité	2	2	2	2	★

Fig. 25

ROTARY SHIFTER

Embrayage de rotobineuse

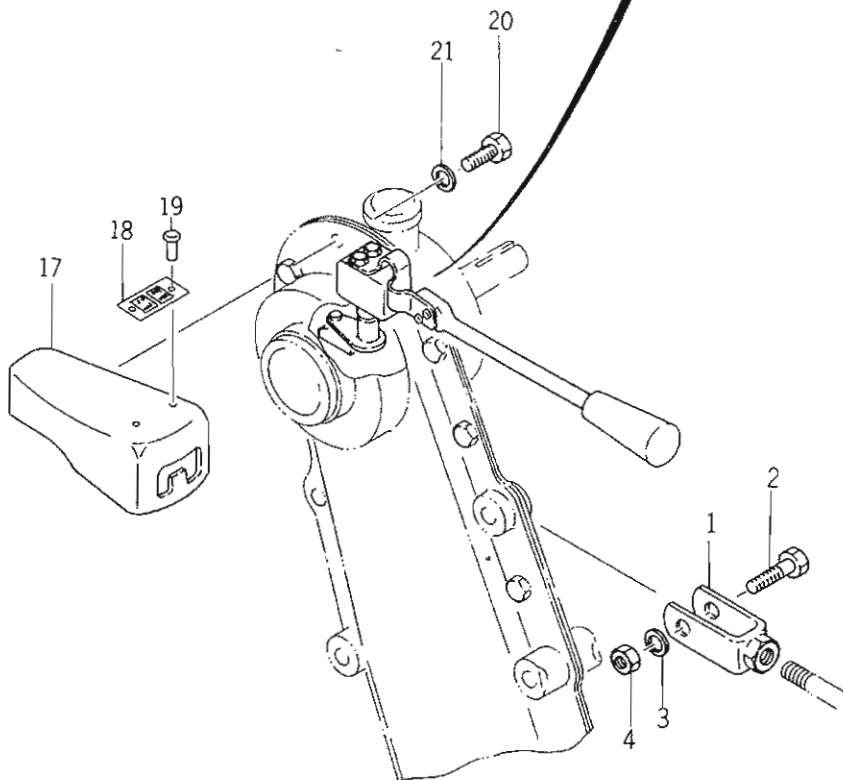
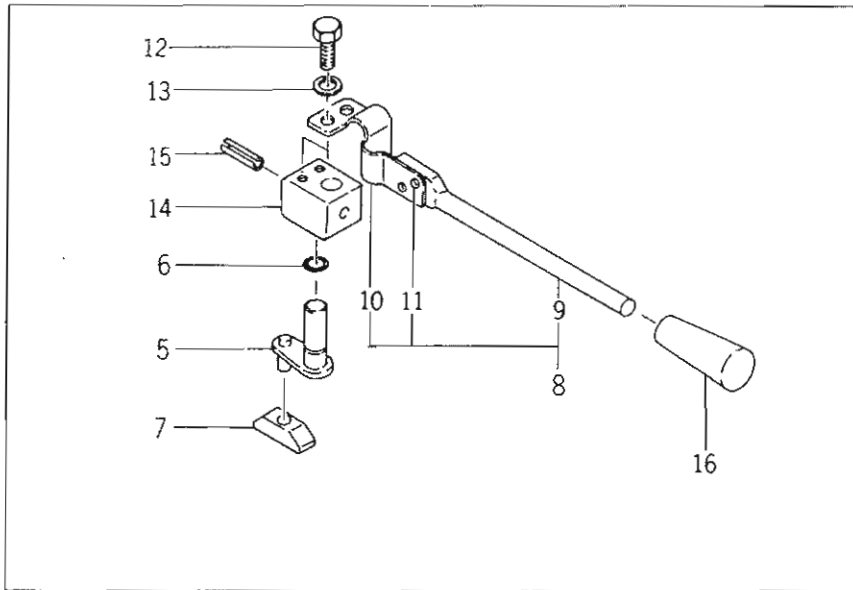



Ref N° Réf N°	Parts No. Pièces No.	Description Désignation	Model & Q'ty Modél & Quant				Remarks Remarques
			F40	F60	F80	F100	
25- 1	1337-706-3000-0	FORK Chape	1	1	1	1	*
25- 2	V20126-100360	BOLT/M10×36 Vis	1	1	1	1	*
25- 3	V40116-001000	WASHER, SP/M10 Rondelle frein	1	1	1	1	*
25- 4	V30026-001000	NUT/M10 Eccrou	1	1	1	1	*
25- 5	1337-706-4001-0	ROD, SHIFTER Selecteur	1	1	1	1	*
25- 6	V72010-190090	O-RING/P9 Joint torique	1	1	1	1	*
25- 7	1340-229-0020-0	SHIFTER, SIDE CLUTCH Flotteur	1	1	1	1	*
25- 8	1337-706-5002-0	LEVER, CLUTCH Lever d'embrayage	1	1	1	1	*
25- 9	1337-706-5051-0	LEVER (C) Lever	1	1	1	1	*
25-10	1337-706-5060-0	SPRING, PLATE Ressort	1	1	1	1	*
25-11	V29010-300090	RIVET/3×9 Rivet	2	2	2	2	*
25-12	V20126-060100	BOLT/M6×10 Vis	2	2	2	2	*
25-13	V40116-000600	WASHER, SP/M6 Rondelle frein	2	2	2	2	*
25-14	1337-706-0030-0	BOSS/25×25 Bossage	1	1	1	1	*
25-15	V58014-040250	PIN, SPRING/4×25 Coupille elastique	1	1	1	1	*
25-16	2101-230-0010-0	GRIP Poignee	1	1	1	1	*
25-17	1337-706-6001-0	GUIDE, CLUTCH Guide de commande	1	1	1	1	*
25-18	1349-955-0010-0	MARK, ROTARY CLUTCH Repere	1	1	1	1	*
25-19	V29120-200040	RIVET/2×4 Rivet	2	2	2	2	*
25-20	V20026-060140	BOLT/M6×14 Vis	2	2	2	2	*
25-21	V40126-000600	WASHER, SP/M6 Rondelle frein	2	2	2	2	*

Fig. 26 ROTARY PIPE  
Fraise

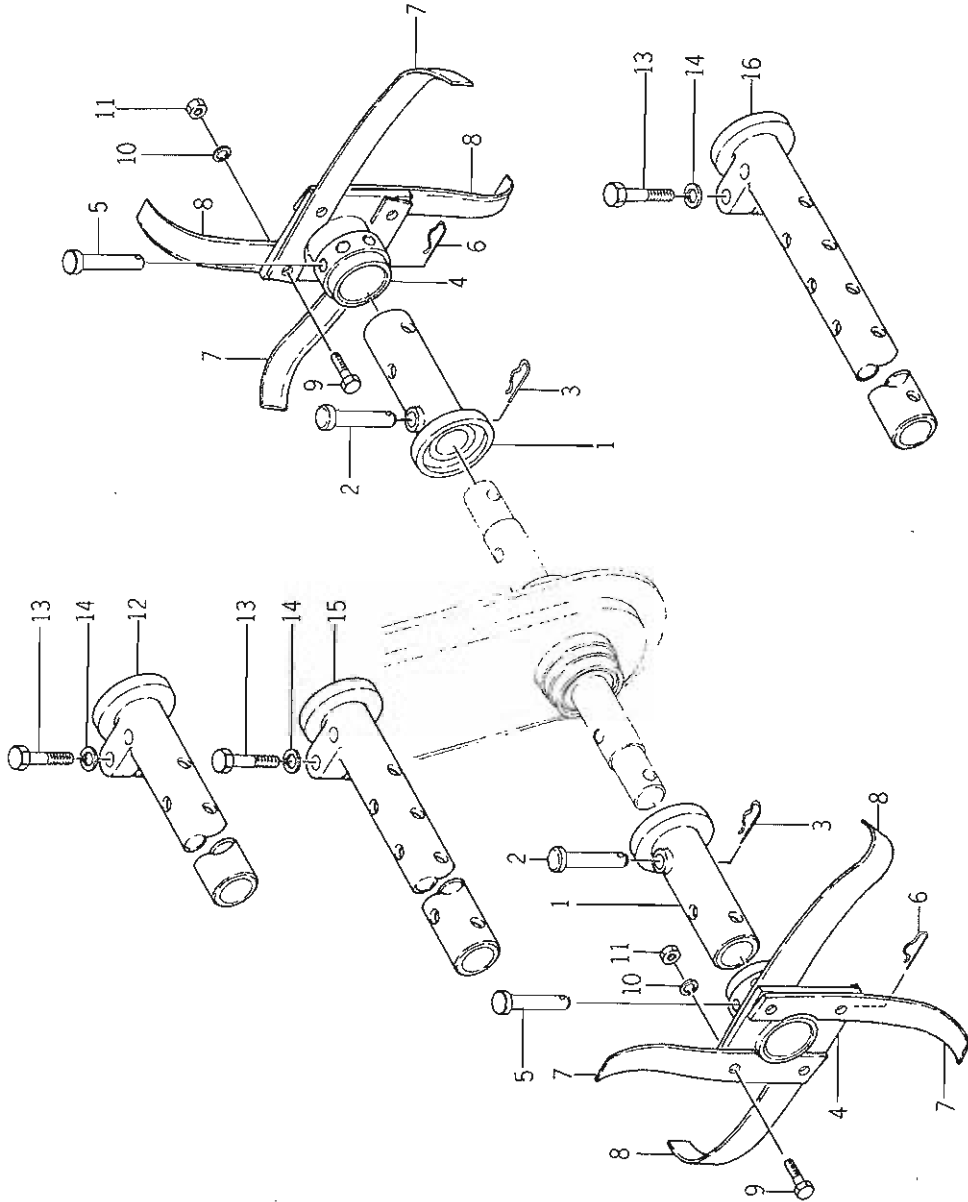

Ref N <sup>o</sup> .	Parts No.	Description	Model & Q'ty				Remarks
			Modél & Quant				
Réf N <sup>o</sup> .	Pièces No.	Désignation	F40	F60	F80	F100	Remarques
26- 1	1329-241-3000-0	PIPE, WHEEL/Z Tube rallonge	2				*
26- 2	1310-241-0030-0	PIN, HEADED A Goupille	2	2	2	2	*
26- 3	1305-241-0010-0	PIN, HAIR Attache beta	2	2	2	2	*
26- 4	1349-716-1000-0	BOSS, BLADE SET Goupille de hoyau	2	4	6	8	*
26- 5	1305-202-0060-0	PIN, HEADED Goupille	2	4	6	8	*
26- 6	1305-241-0010-0	PIN, HAIR Attache beta	2	4	6	8	*
26- 7	1349-716-0010-0	BLADE, LH/C118 Hoyau G.	4	8	12	16	*
26- 8	1349-716-0020-0	BLADE, RH/C118 Hoyau D.	4	8	12	16	*
26- 9	V20136-080250	BOLT/M8×25 Vis	8	16	24	32	*
26-10	V40116-000800	WASHER, SP/M8 Rondelle frein	8	16	24	32	*
26-11	V30026-000800	NUT/M8 Ecrou	8	16	24	32	*
26-12	1331-253-1000-0	PIPE, WHEEL/230 Tube rallonge		2			*
26-13	V20126-120500	BOLT/M12×50 Vis		2	2	2	*
26-14	V40116-001200	WASHER, SP/M12 Rondelle frein		2	2	2	*
26-15	1331-253-2000-0	PIPE, WHEEL/330 Tube rallonge			2		*
26-16	1331-253-3000-0	PIPE, WHEEL/430 Tube rallonge				2	*

Fig.27

ROTARY FRAME  
Enveloppe de rotobineuses

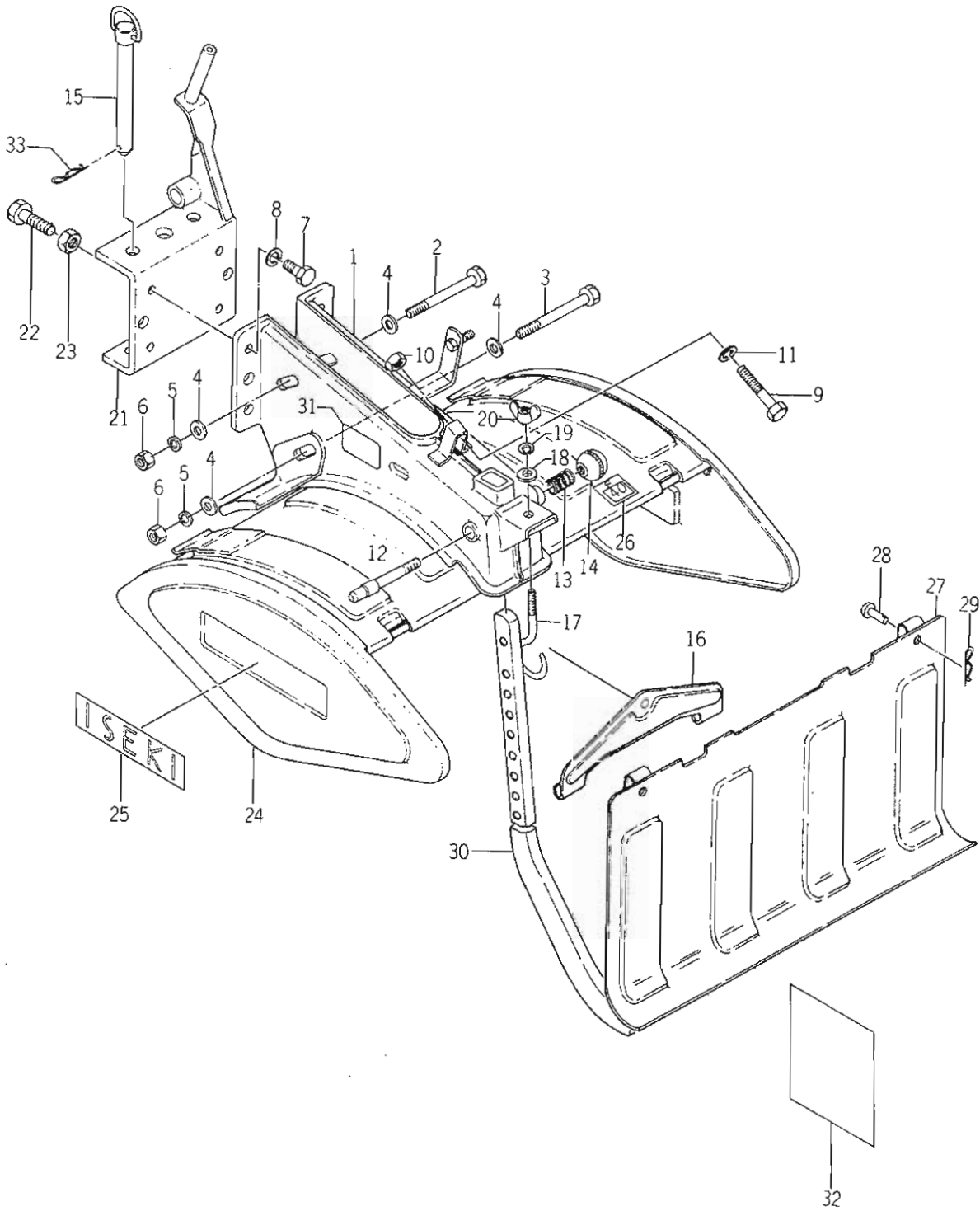

Ref N° Réf N°	Parts No. Pièces No.	Description Désignation	Model & Q'ty Modél & Quant				Remarks Remarques
			F40	F60	F80	F100	
27- 1	1349-721-1000-0	FRAME, ROTARY Chassis	1	1	1	1	★
27- 2	V20126-100900	BOLT/M10×90 Vis	2	2	2	2	★
27- 3	V20126-100950	BOLT/M10×95 Vis	1	1	1	1	★
27- 4	V41316-001000	WASHER, PL/M10 Rondelle	6	6	6	6	★
27- 5	V40116-001000	WASHER, SP/M10 Rondelle frein	3	3	3	3	★
27- 6	V30026-001000	NUT/M10 Ecrou	3	3	3	3	★
27- 7	V20126-100250	BOLT/M10×25 Vis	4	4	4	4	★
27- 8	V40116-001000	WASHER, SP/M10 Rondelle frein	4	4	4	4	★
27- 9	1349-721-0030-0	BOLT/M10×71 S=40 Vis	1	1	1	1	★
27-10	V30226-001000	NUT/M10 Ecrou	1	1	1	1	★
27-11	1337-721-0020-0	WASHER/11×24×3 Rondelle	1	1	1	1	★
27-12	1349-721-0010-0	PIN, ADJ Tenon	1	1	1	1	★
27-13	1350-311-0030-0	SPRING, PRESS/38 Resort	1	1	1	1	★
27-14	1407-117-0031-0	KNOB, LEVER/31 Pommeau	1	1	1	1	★
27-15	1349-721-3100-0	PIN Goupille	2	2	2	2	★
27-16	1349-721-3000-0	HANGER, COVER Support	1	1	1	1	★
27-17	1349-721-0020-0	HOOK Crochet	1	1	1	1	★
27-18	V41316-000800	WASHER, PL/M8 Rondelle	1	1	1	1	★
27-19	V40116-000800	WASHER, SP/M8 Rondelle frein	1	1	1	1	★
27-20	V37016-000600	NUT, WING/M8 Ecrou a oreilles	1	1	1	1	★
27-21	1365-772-2000-0	HITCH, ROTARY Attelage	1	1	1	1	★
27-22	V20026-120450	BOLT/M12×45 Vis	2	2	2	2	★
27-23	V30226-001200	NUT/M12 Ecrou	2	2	2	2	★
27-24	1349-723-1000-0	COVER, ROTARY/40 Bavolet	1				★
27-24-1	1349-756-1000-0	COVER, ROTARY/60 Bavolet		1			★
27-24-2	1349-757-1000-0	COVER, ROTARY/80 Bavolet			1		★
27-24-3	1349-758-1000-0	COVER, ROTARY/100 Bavolet				1	★
27-25	1326-953-0070-0	MARK, ISEKI Etiquette	2	2	2	2	★
27-26	1349-956-0010-0	MARK, TYPE/40 Etiquette	1				★
27-26-1	1349-956-0020-0	MARK, TYPE/60 Etiquette		1			★
27-26-2	1349-956-0030-0	MARK, TYPE/80 Etiquette			1		★
27-26-3	1349-956-0040-0	MARK, TYPE/100 Etiquette				1	★
27-27	1349-723-2000-0	GUARD, MUD/40 Bavette	1				★
27-27-1	1349-756-2000-0	GUARD, MUD/60 Bavette		1			★
27-27-2	1349-757-2000-0	GUARD, MUD/80 Bavette			1		★
27-27-3	1349-758-2000-0	GUARD, MUD/100 Bavette				1	★
27-28	1349-723-0010-0	PIN/8×22 Goupille	2	2	4	4	★
27-29	1305-241-0010-0	PIN, HAIR Attache beta	2	2	4	4	★

Fig. 27 ROTARY FRAME  
 Enveloppe de rotobineuses

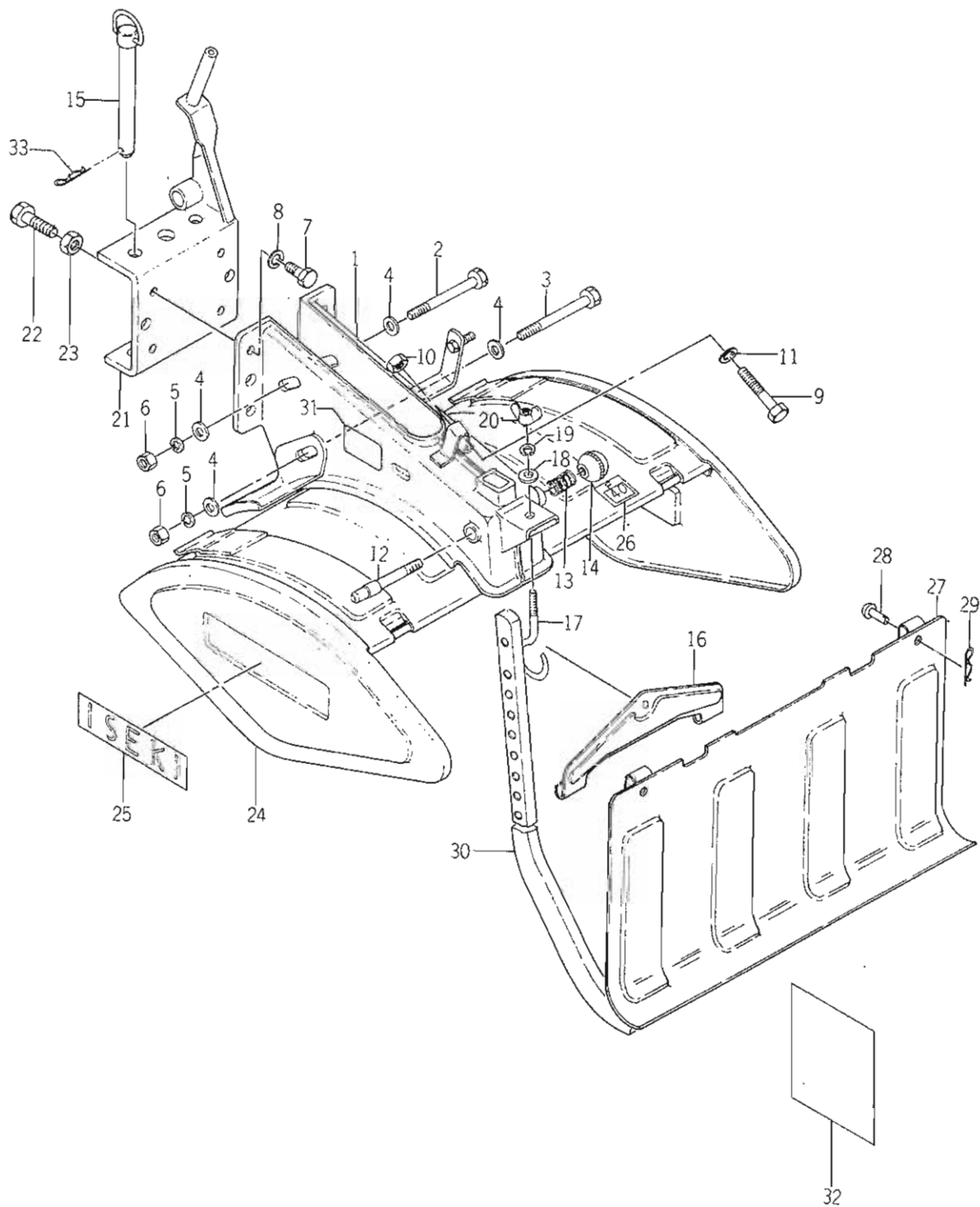

Ref N <sup>o</sup> .	Parts No.	Description	Model & Q'ty				Remarks
			Modél & Quant				
Réf N <sup>o</sup> .	Pièces No.	Désignation	F40	F60	F80	F100	Remarques
27-30	1349-726-0010-0	SKID, CENTER Barre de profondeur	1	1	1	1	*
27-31	1349-956-0060-0	MARK, ROTARY OIL Etiquette	1	1	1	1	*
27-32	1349-956-0070-0	MANUAL, ASSEMBLING Manuel	1	1	1	1	* For 650E
27-32-1	1365-966-0010-0	MANUAL, ASSEMBLING Manuel	1	1	1	1	* For 650, 650D
27-33	1305-931-0030-0	PIN, KING ASSY/134 Attache beta	2	2	2	2	*



**Yvan Béal - 21, av. de l'Agriculture - B.P. 16  
Z.I. du Brézet - 63014 Clermont-Ferrand Cedex 2  
Tél : 04 73 91 93 51 - Télécopie : 04 73 90 23 11  
[www.yvanbeal.fr](http://www.yvanbeal.fr) - E-mail : [info@yvanbeal.fr](mailto:info@yvanbeal.fr)  
R.C.S. Clermont-Fd B 304 973 886 - S.A.S. au capital de 612 000 €**