

Pièces de rechange

Spare parts list

Roto

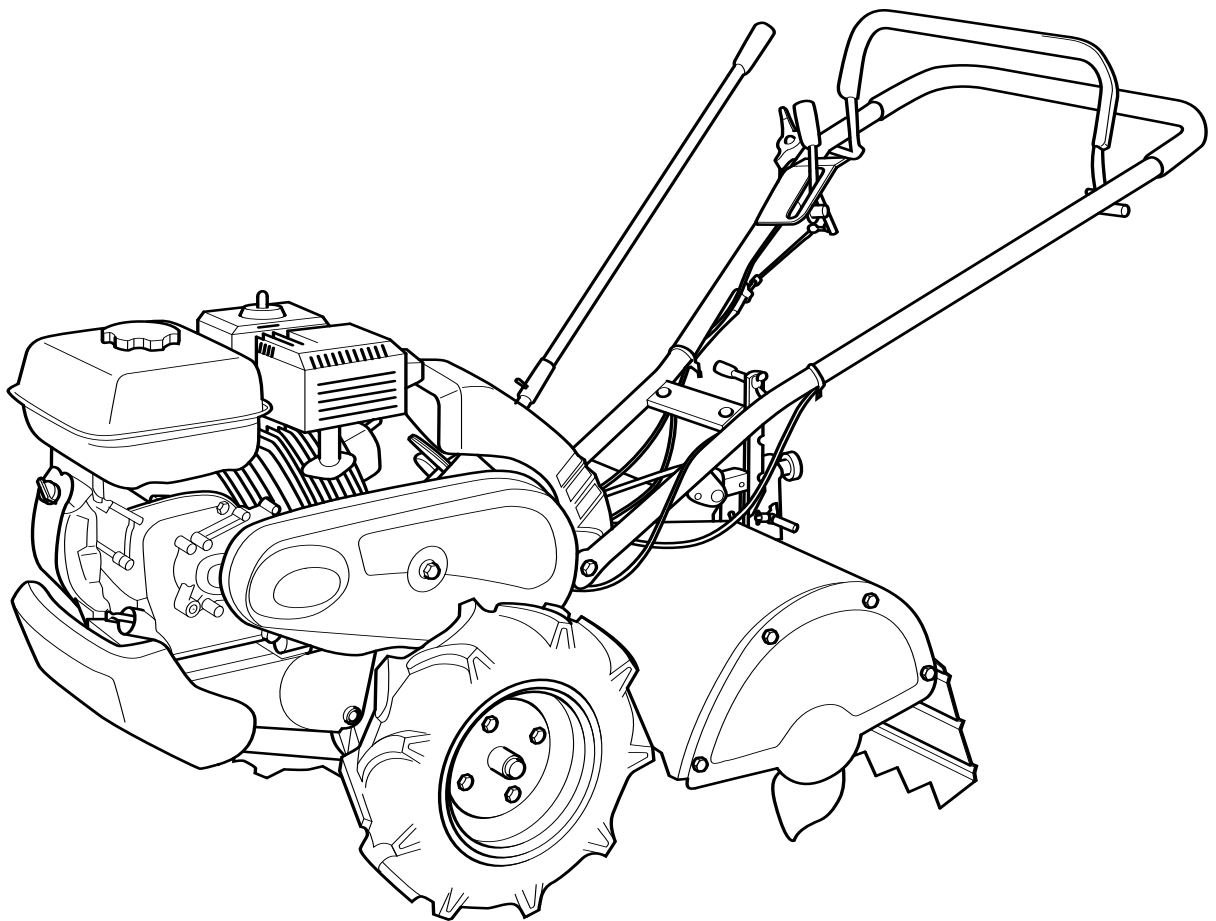

MONTAGE MOTEUR ENGINE CONSTRUCTION

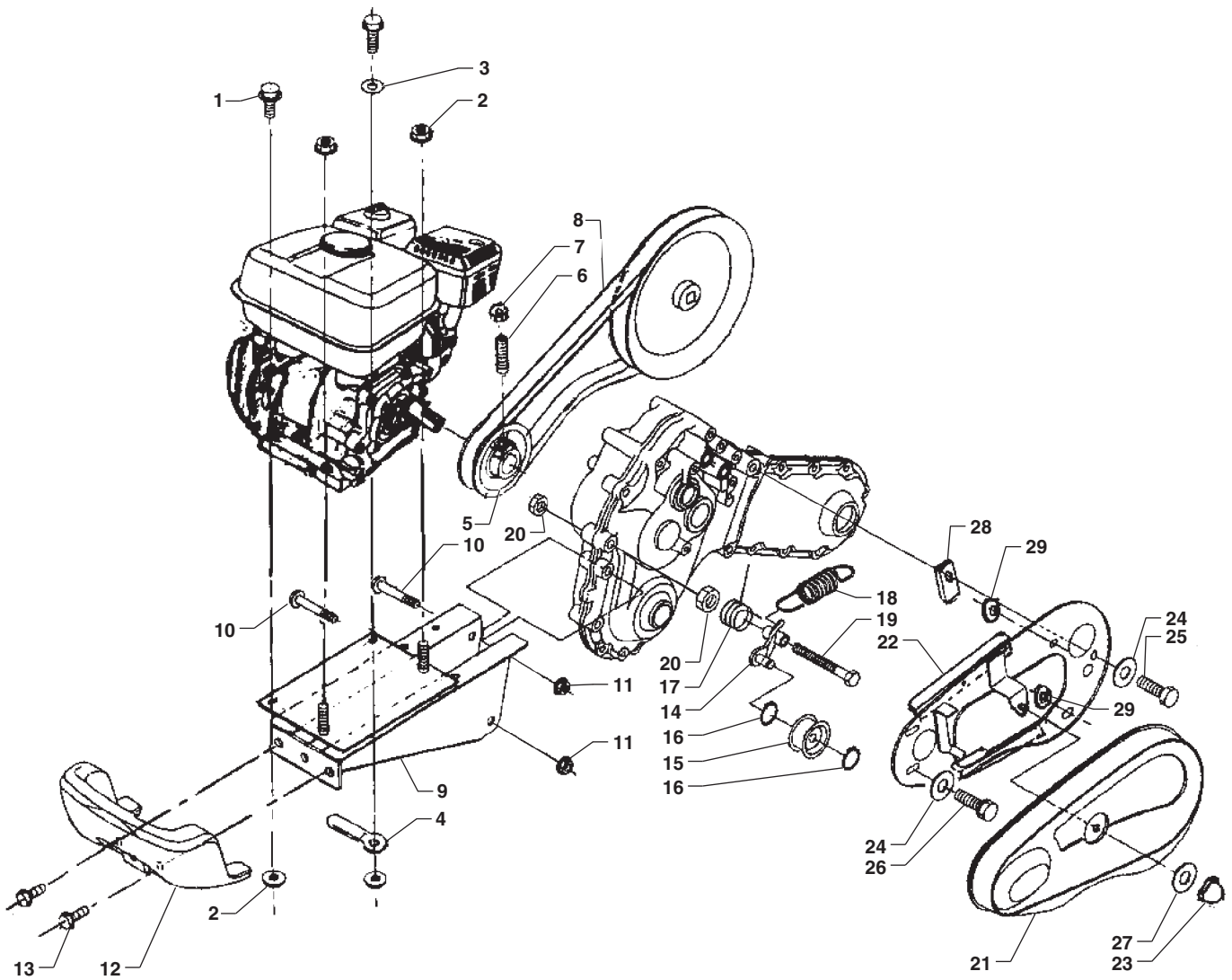



Rep N°	Réf./Ref.		Désignation	Description	Qté Qty
1	0300010834	F050 0108 035	Vis M8 x 35 emb crantée	BOLT flange M8 x 35	2
2	0300260801	F301 0108 000	Écrou M8 emb crantée	NUT flange M8	4
3	0300400802	0350 0140 818	Rondelle 8 x 18 x 1,5	WASHER 8 x 18 x 1,5	1
4	0002010020	0050 2108 083	Agrafe L 80	CLAMP L=80	1
5	0002010021	P506 0201 000	POULIE	V-PULLEY 70	1
6	0300040804	03650-50814	Vis STHc M8 x 16	SET SCREWS STHc M8 x 16	1
7	0300250801	A301 0108 003	Écrou HhM8	NUT Hh M8	1
8	0001000279	0852 1500 037	Courroie SB37	V-BELT SB37	1
9	0002010278	P506 2301 000	Chassis	ENGINE FRAME	1
10		F050 0110 060	Vis M10 x 60 emb crantée	BOLT flange M10 x 60	2
11	0300261001	F301 0110 000	Écrou M10 emb crantée	NUT flange M10	2
12	0002010279	1490 2352 000	Contre poids	BALANCE WEIGHT	1
13		F050 0110 030	Vis M10 x 30 emb crantée	BOLT flange M10 x 30	2
14	0002010024	1490 1516 000	Support galet tendeur	ARM	1
15	0002010025	3610 1506 000	Galet tendeur	PULLEY tight	1
16	0002010023	0740 0001 200	Circlips Ext. Ø12	C-RING Ø12	2
17	0002010026	1429 1508 000	RESSORT	SPRING	1
18	0002010042	1425 1509 000	RESSORT	SPRING	1
19		1421 1511 000	VIS HM12 x 100	BOLT HM12 x 100	1
20	0300201202	A301 0112 002	ÉCROU HM12	NUT HM12	2
21	0002010010	1490 1551 000	CAPOT COURROIE	COVER	1
22	0002010028	P506 1557 000	CACHE INTÉRIEUR	COVER	1
23	11513	A341 0130 802	ÉCROU M8 borgne	NUT M8	1
24		0350 0130 820	RONDELLE 8 x 20 x 1	WASHER 8 x 20 x 1	5
25		A800 0108 020	VIS M8 x 16	CT-BOLT M8 x 16	3
26	0300010815	F050 0108 016	VIS M8 x 16 emb crantée	BOLT flange M8 x 16	2
27		0350 0150 822	RONDELLE 8 x 22 x 2	WASHER 8 x 22 x 2	1
28	0002010280	1490 1559 000	PLAQUE	PLATE	1
29		2701 4273 000	RONDELLE 8 x 20 x 4,5	WASHER 8 x 20 x 4,5	2

BOITE DE TRANSMISSION TRANSMISSION CASE

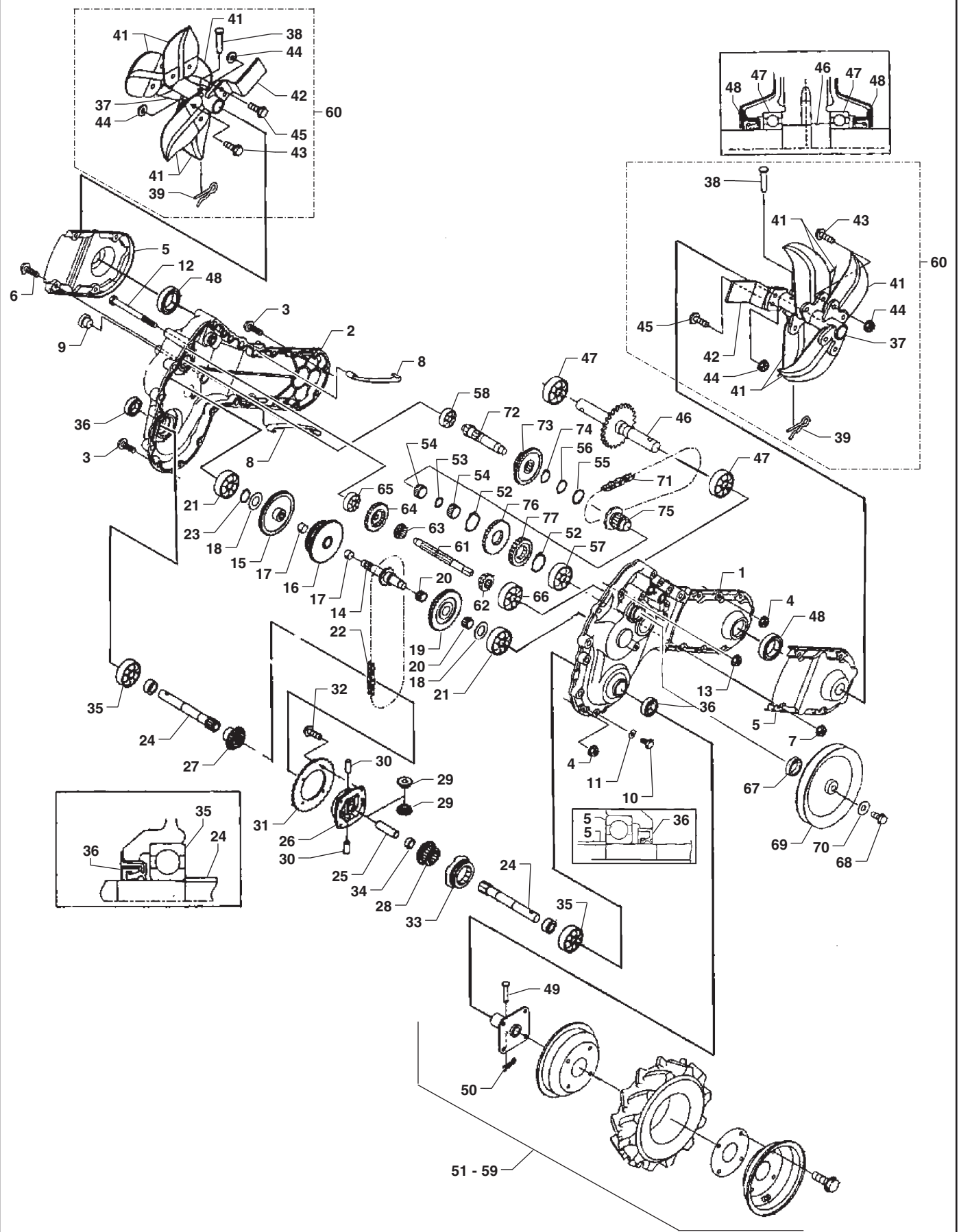



Rep N°	Ref./Ref.	Désignation	Description	Qté Qty	
1	0002010012	P506 1051 000	Transmission complète	Assembly transmission	1
2	0002010074	1429 1005 000	Carter Gauche	CASE LA	1
3	0002010075	1429 1006 000	Carter Droit	CASE RA	1
4	0300260801	F050 0108 030	Vis M8 x 30 emb crantée	BOLT flange M8 x 30	8
5	0002010073	F301 0108 000	Écrou M8 emb crantée	NUT flange M8	8
6	0300010834	1429 1011 000	Couvercle	COVER	2
7	0300260801	F050 0108 035	Vis M8 x 35 emb crantée	BOLT flange M8 x 35	2
8	0002010198	F301 0108 000	Écrou M8 emb crantée	NUT flange M8	2
9	0002010202	1429 101 5001	Ressort	SPRING	2
10	0002010203	3150 1016 000	Bouchon d'huile	PLUG oil	1
11		2740 3214 200	Bouchon	PLUG	1
12		0833 1000 800	Rondelle joint M8	WASHER seal M8	1
13	0300260801	A054 0108 110	Vis M8 x 110 emb crantée	BOLT 7T M8 x 110	2
14	0002010281	F301 0108 000	Écrou M8 emb crantée	NUT flange M8	2
15	0002010282	1429 1151 001	Axe	SHAFT 3	1
16	0002010283	1429 1152 001	Pignon 50 50T	GEAR 50 50T	1
17	0002010284	1429 1153 000	Pignon 36-49 36-49T	GEAR 36-49 36-49T	1
18	0002010191	0797 2018 120	Bague	BUSHING	2
19	0002010085	2761 3113 000	Rondelle 15 x 25 x 1	Washer 15 x 25 x 1	2
20	0002010077	1429 1156 000	Pignon 24-35 24-35T	GEAR 24-35 24-35T	1
21	0002010076	1429 1159 000	Roulement 6202	BEARIGN needle	2
22	0002010081	0750 0062 020	Roulement 6202 2RS	BEARING ball 6202	2
23	0301070002	0870 2110 400	Chaîne 40L	CHAIN 40L	1
24	0002010286	0740 0001 500	Circlips Ext. Ø15	C-RING Ø15	1
25		1429 1252 001	Arbre de roue	FINAL SHAFT	2
26	0002010287	0540 0116 063	Goupille	PIN	1
27	0002010288	1429 1254 000	Renvoi d'angle	CASE diff	1
28	0002010289	1429 1255 000	Pignon 22A 22T	GEAR 22A side 22T	1
29	0002010290	1429 1258 000	Pignon 22B 22T	GEAR 22B side 22T	1
30	0002010285	1429 1267 000	Pignon 13	PINION 13	2
31	0002010291	1429 1259 000	Goupille	PIN center	2
32	0300010613	1429 1266 000	Courroie 30 dents 30T	GEAR 30T	1
33	0002010292	F050 0106 012	Vis HM6 x 12 emb crantée	BOLT flange M6 x 12	4
34	0002010293	1429 1268 000	Manchon	SLEEVE	1
35	0002010078	1429 1269 000	Entretoise	COLLAR	1
36	0001000288	0750 0062 040	Roulement 6204	BEARING ball 6204	2
37		2740 3624 100	Joint SPI 20 x 32 x 9,5	SPI SEAL 20 x 32 x 9,5	2
38	0001000283	NON DETAILLE	Table de rotation	PIPE rotary	2
39	0002010003	1924 1311 000	Axe goupille 10 x 50	PIN cleves 10 x 50	2
40		1924 1312 000	Goupille Bêta 2,5 x 37	PIN snap 2,5 x 37	2
41	0001000284	1429 1326 000	Dent compteur	TINE ASSY	1
42	0002010031	1924 1317 001	Couteau fraise	BLADE	10
43		1924 1318 003	Couteau racleur	BLADE	2
44		NON DETAILLE	Vis M10 x 20 emb crantée	BOLT flange M10 x 20	20
45	0002010014	NON DETAILLE	Écrou M10 emb crantée	NUT flange M10	24
46	0002010082	F050 0110 025	Vis M10 x 25 emb crantée	BOLT flange M10 x 25	4
47	0002010079	1428 1321 000	Arbre d'entraînement	ROTARY SHAFT	1
48	0002010086	0750 0060 050	Roulement 6005	BEARING ball 6005	2
49	0302010040	0841 2254 011	Joint SPI 25 x 40 x 11,5	SPI SEAL 25 x 40 x 11,5	2
50	0002010337	0562 1108 040	Axe goupille 8 x 40	PIN clevis 8 x 40	2
51	0002010032	0521 0108 000	Goupille Bêta 1,5 x 28	PIN snap Ø 1,5 x 28	2
52	0002010325	1490 1371 000	Roue complète G	TIRE LH ASSY	1
53	0002010326	0740 0003 500	Circlips Ext. Ø 35	C-RING Ø 35	2
54	0002010327	1429 1112 001	Entretoise	COLLAR	1
55	0002010328	1429 1113 000	Roulement	BEARING needle	2
56	0301070007	1414 1108 000	Rondelle	LENER	1
57	0002010330	0740 0002 000	Circlips Ext. Ø 20	C-RING Ø 20	1
58	0002010076	0750 0063 020	Roulement 6302	BEARING ball 6302	1
59	0002010033	0750 0062 020	Roulement 6202	BEARING ball 6202	1
60	0002010071	1490 1381 000	Roue complète D	TIRE RH ASSY	1
61	0002010295	1429 1333 000	Fraise droite ou gauche complète	Tines Right or left Assembly	2
62	0002010089	1429 1051 000	Axe	SHAFT 1	1
63	0002010263	1429 1056 000	Pignon 14T	GEAR 14T	1
64	0002010296	1429 1052 000	Pignon 14T	GEAR 14T	1
65	0002010217	1429 1053 000	Pignon 31T	GEAR 31T	1
66	0002010330	0750 0062 010	Roulement 6201	BEARING ball 6201	1
67	0002010087	0750 0063 020	Roulement 6302	BEARING ball 6302	1
68	0300010816	0840 1015 307	Joint TC 15 x 30 x 7	SEAL oil TC 15 x 30 x 7	1
69	0002010264	F050 0108 020	Vis M8 x 20 emb crantée	BOLT flange M8 x 20	1
70		1490 1063 000	Poulie 171	V-PULLEY 171	1
71	0002010080	0350 0160 826	Rondelle 8 x 26 x 3	WASHER 8 x 26 x 3	1
72		0870 2320 560	Chaîne	CHAIN	1
73	0002010298	1429 1101 001	Axe	SHAFT	1
74	0002010227	1429 1102 000	Pignon 25-41T	GEAR 25-41T	1
75	0002010331	0740 0002 200	Circlips Ext. Ø 22	C-RING Ø 22	1
76	0002010090	1429 1104 001	Pignon 9T	SPROCKET 9T	1
77	0002010091	1429 1105 000	Pignon 31T	GEAR 31T	1
		1429 1106 000	Pignon 23T	GEAR 23T	1

SELECTEUR CHANGE

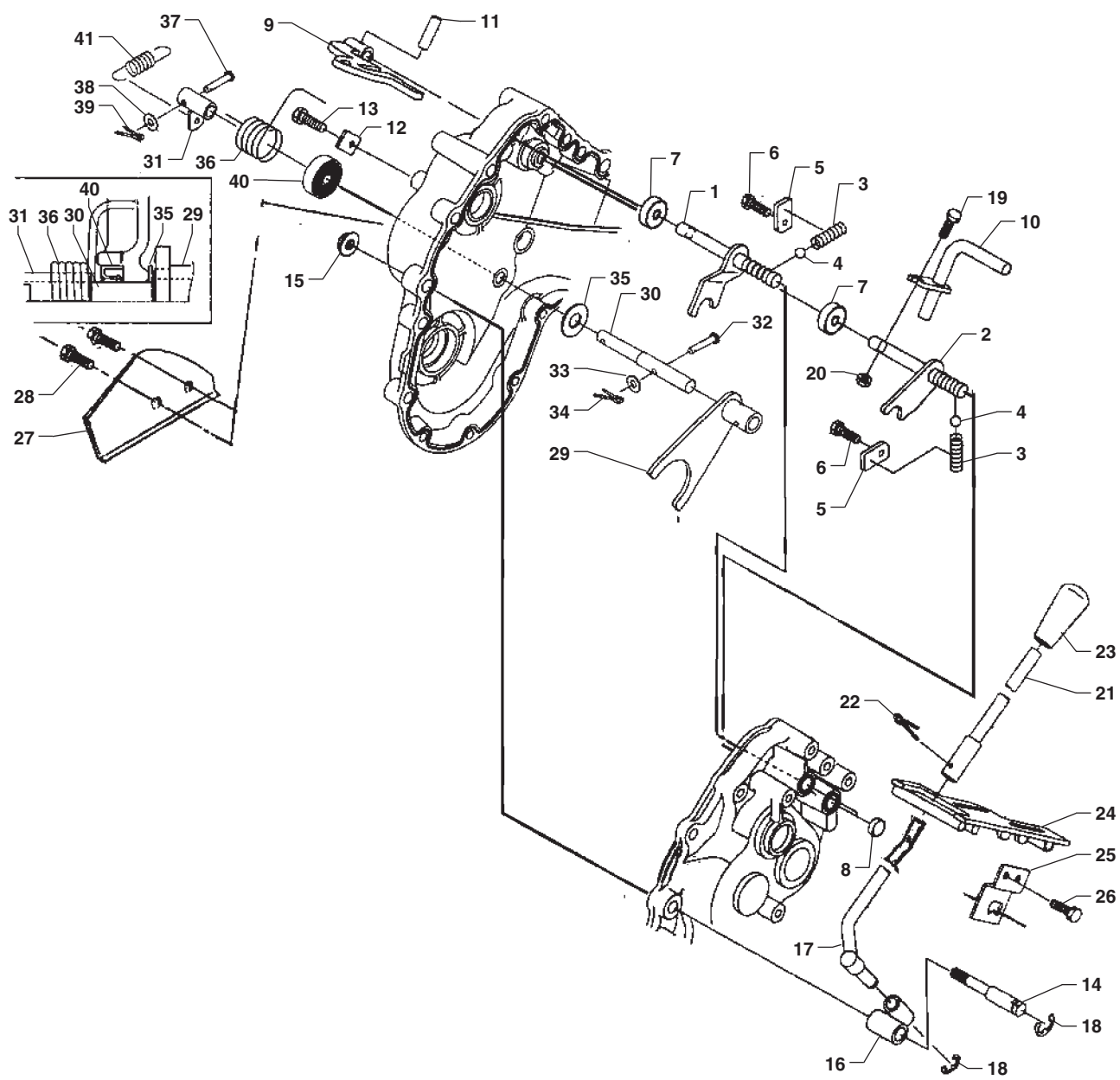
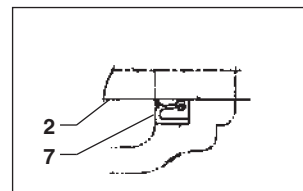
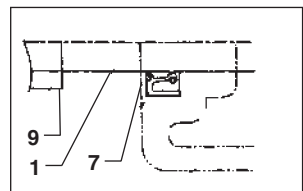



Rep N°	Réf./Ref.		Désignation	Description	Qté Qty
1	0002010299	1429 1401 000	Fourchette D	SHIFTER D	1
2	0002010275	1429 1402 001	Fourchette G	SHIFTER R	1
3	0002010197	1429 1418 000	Ressort	SPRING	2
4	0002010196	0800 0000 600	BILLE 1/4"	BALL 1/4"	2
5	0002010300	1429 1403 000	Patte	PLATE	2
6	0300010609	A800 0106 016	Vis M6 x 16 emb crantée	CT-BOLT M6 x 16	2
7	0002010002	0840 1012 227	JOINT TC12 x 22 x 7	SEAL oil TC12 x 22 x 7	2
8	0002010088	0834 0020 070	Joint bouchon Ø 20 x 7	CAP seal Ø 20 x 7	2
9	0002010045	1429 1404 000	Bras A	ARM A	1
10	0002010034	1429 1405 000	Bras B	ARM B	1
11		0550 0006 025	Goupille ø6 x 25	PIN spring ø6 x 25	1
12	0002010301	1429 1406 000	Plaque	PLATE	1
13	0300010609	A800 0106 016	Vis M6 x 16 emb crantée	CT-BOLT M6 x 16	1
14	0002010035	1429 1407 000	Axe	SHAFT	1
15	0300261001	F301 0110 000	Écrou M10 emb crantée	NUT flange M10	1
16	0002010036	1429 1408 000	Pièce de commande	BOSS	1
17	0002010037	P506 1409 000	Levier	LEVER	1
18		7420101000	Anneau Truarc E10	E-RING E10	2
19		A524 0106 025	Vis spéciale	BOLT	1
20	0300200601	A300 0106 002	Écrou HM6	NUT HM6	1
21	0002010038	1490 1412 000	Levier	LEVER	1
22	0002010039	0520 0125 025	Goupille fendue Ø 2,5 x 25	PIN split Ø 2,5 x 25	1
23	0002010040	0691 0012 250	Poignée	GRIP	1
24	0002010302	1429 1413 000	Console de levier	LEVER PLATE	1
25	0002010303	1429 1416 000	Patte support console	PLATE support	1
26	0300010609	F050 0106 016	Vis M6 x 16 emb crantée	BOLT flange M6 x 16	2
27	0002010304	P506 1418 000	Plaque	PLATE	1
28	0300010801	A800 0108 016	Vis M8 x 16	CT-BOLT M8 x 16	2
29	0002010305	1429 1601 000	Fourchette	ARM	1
30	0002010306	1429 1609 000	Axe	SHAFT	1
31	0002010043	1429 1621 000	Sélecteur	ARM	1
32	0002010307	0562 1106 030	Axe goupille 6 x 30	PIN clevis 6 x 30	1
33		0350 0130 613	Rondelle 6 x 15 x 1	WASHER 6 x 15 x 1	1
34	0002010192	0520 0125 012	Goupille fendue Ø 2,5 x 12	PIN split Ø 2,5 x 12	1
35		3121 255 9000	Rondelle	LINER	1
36	0002010041	1429 1626 000	Ressort	SPRING	1
37	0002010193	0562 1106 025	Axe goupille 6x25	PIN clevis 6x25	1
38		0350 0130 613	Rondelle 6 x 15 x 1	WASHER 6 x 15 x 1	1
39	0002010192	0520 0125 012	Goupille fendue Ø 2,5 x 12	PIN split Ø 2,5 x 12	1
40	0002010002	0840 1012 227	Joint TC 12 x 22 x 7	SEAL oil TC 12 x 22 x 7	1
41	0002010042	1425 1509 000	Ressort	SPRING	1

GUIDON HANDLE

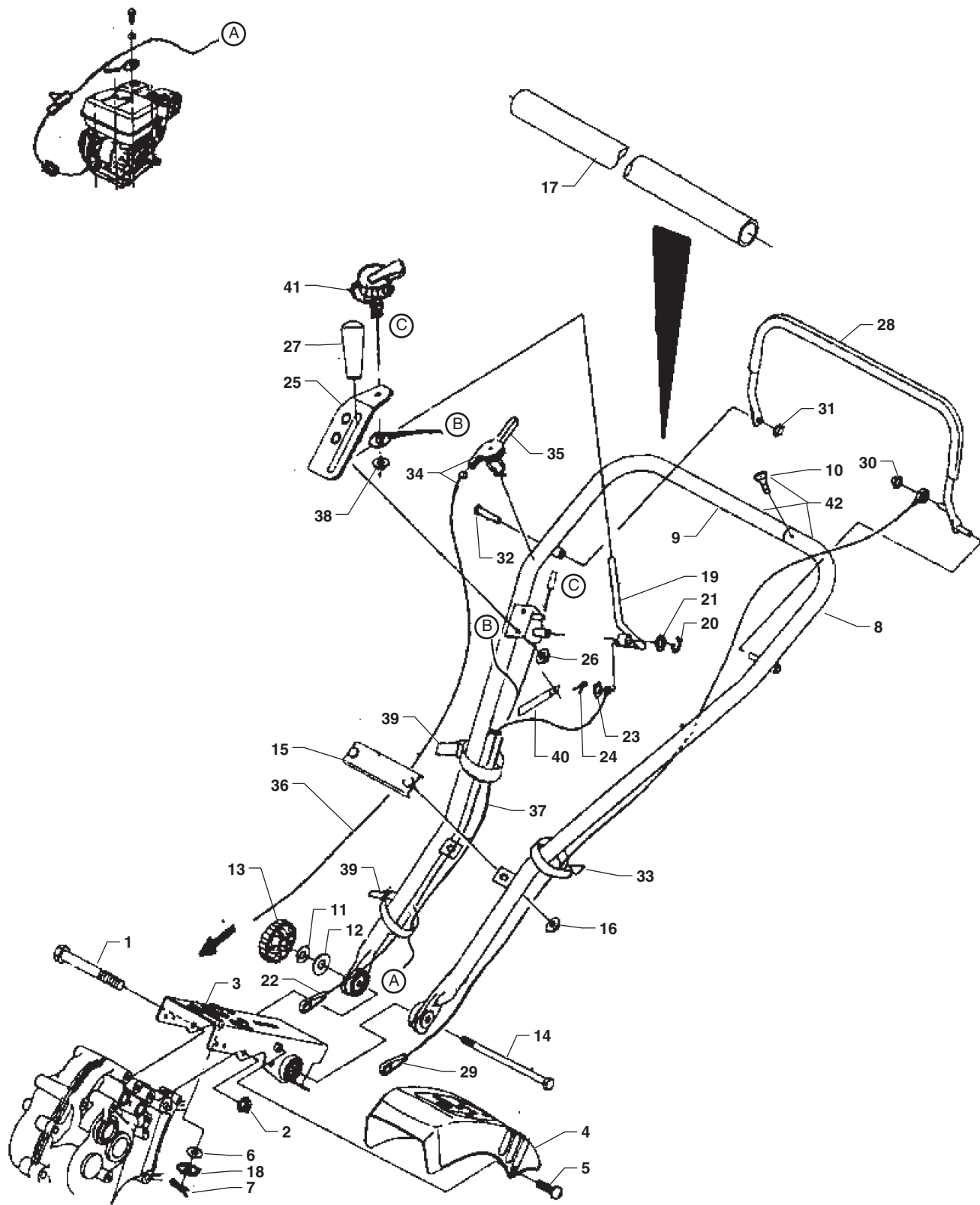



Rep N°	Réf./Ref.	Désignation	Description	Qté Qty
1	A054 0108 125	Vis M8 x 125	BOLT 7T M8 x 125	2
2	0300260801 F301 0108 000	Écrou M8 emb crantée	NUT flange M8	2
3	0002010308 1429 2001 000	Tole de fixation Bras Rouge 3002	FRAME handle Red 3002	1
	0002010310	Tole de fixation Bras Orange 2004	FRAME handle Orange 2004	1
	0002010311	Tole de fixation Bleu P301	FRAME Blue P301	1
4	0002010309 1490 2031 000	Couvercle	COVER A panel	1
5	0001000287 1924 2206 000	Vis M6 spéciale	M6 SCREW	2
6	0300400802 0350 0140 818	Rondelle 8 x 18 x 1,5	WASHER 8 x 18 x 1,5	2
7	0002010337 0521 0108 000	Goupille beta 1,5x28	PIN snap 2x25	2
8	0002010269 P506 2052 000	Demi-guidon G	HANDLE LH	1
9	0002010270 P506 2053 000	Demi-guidon D	HANDLE RH	1
10	A222 0106 016	Vis TF M6 x 16	TF M6 x 16 SCREW	1
11	0300451001 A360 0101 002	Rondelle Grower 10	Grower WASHER 10	1
12	0350 0151 026	Rondelle 10x26x2	WASHER 10x26x2	1
13	0002010047 1429 2061 000	Molette M10	GRIP M10	1
14	0002010048 1429 2062 000	Vis M10x185	BOLT M10x185	1
15	0002010312 1429 2056 000	Patte	PLATE	1
16	0300260801 F301 0108 000	Écrou M8 emb crantée	NUT flange M8	2
17	0002010083 1924 2061 000	Poignée caoutchouc	GRIP	1
18	0833 1000 800	Rondelle 8 x 20 x 2	WASHER seal 8 x 20 x 2	2
19	0002010195 149 02123 000	Levier	LEVER	1
20	0002010194 0742 0100 900	Anneau Truarc E9	E-RING Truarc E9	1
21	0731 0101 210	Rondelle t =1.0 13 x 18,5 x 1	LINER t =1.0 13 x 18,5 x 1	1
22	0002010053 P506 2121 000	Câble de débrabotage	WIRE	1
23	0350 0130 615	Rondelle M6	WASHER M6	1
24	0002010192 0520 0125 012	Goupille fendue Ø 2,5 x12	PIN split Ø 2,5 x12	1
25	0002010313 1429 2131 000	Platine support switch	PLATE	1
26	0300260601 F300 0106 000	Écrou M6 emb crantée	NUT flange M6	2
27	0002010049 0691 0010 257	Poignée	GRIP	1
28	0002010268 1924 2105 001	Levier	LEVER clutch	1
29	0001000293 P506 2106 000	Câble d'embrayage	CLUTCH CABLE	1
30	0002010272 1924 2107 000	Enjoliveur Starlock D6	CAP NUT Starlock D6	1
31	0001000286 1924 2108 000	Enjoliveur Starlock D8	CAP NUT Starlock D8	1
32	0002010050 1924 2109 000	Axe goupille 8x45	PIN clevis 8x45	1
33	0002010314 0051 1032 070	Collier	BAND wire	1
34	0002010084 P506 2158 000	Levier complet	LEVER ASSY	1
35	0002010051 0687 2025 431	Levier	THROTTLE LEVER	1
36	0001000295 P506 2159 000	Câble de gaz	GAS CABLE	1
37	0002010265 P506 2161 000	Câble électrique	LEAD WIRE	1
38	0300260801 F301 0108 000	Écrou M8 emb crantée	NUT flange M8	1
39	0002010314 0051 1032 070	Collier	BAND WIRE	2
40	0002010316 0050 2108 063	Agrafe L=80	CLAMP L=80	1
41	0002010055 P506 2165 000	SWITCH STOP	STOP SWITCH	1
42	0002010271 P506 2051 000	Ensemble guidon complet	HANDLE	1

CARTER DE ROTATION ROTARY COVER

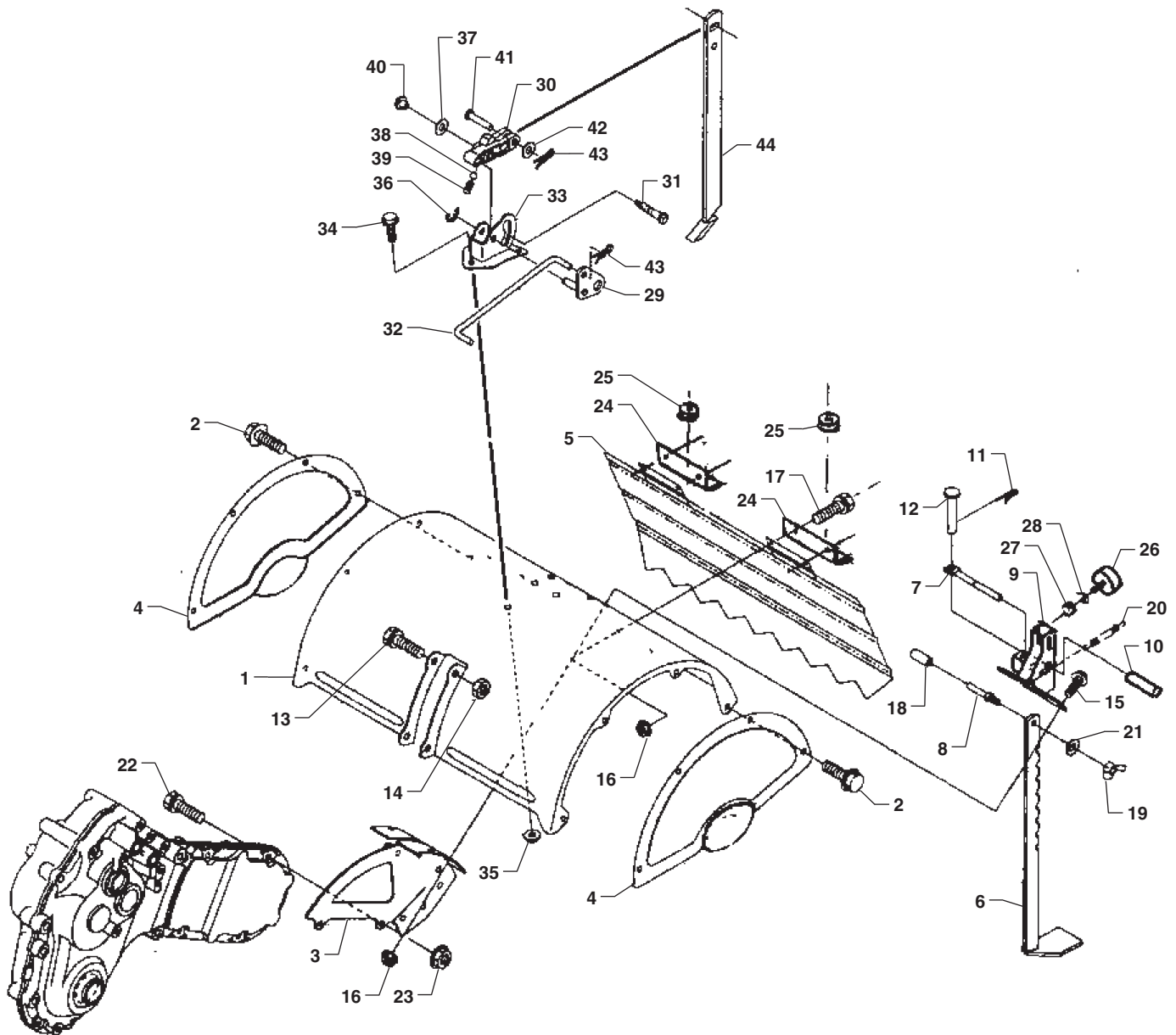



Rep N°	Réf./Ref.		Désignation	Description	Qté Qty
1	0002010266	P506 2201 000	CARTER DE FRAISE Rouge	CUTTER COVER Red	1
	0002010315		CARTER DE FRAISE Orange	CUTTER COVER Orange	1
	0002010317		CARTER DE FRAISE Bleu	CUTTER COVER Blue	1
2	0300010815	H114 0108 016	VIS M8x16 emb cr	BOLT w/washer M8x16	8
3	0002010274	1429 2202 001	PLAQUE SUPPORT Rouge 3002	PLATE Red 3002	1
	0002010044		PLAQUE SUPPORT Orange 2004	PLATE Orange 2004	1
	0002010199		PLAQUE SUPPORT Bleu P301	PLATE Blue P301	1
4	0002010319	P506 2204 000	CARTER DE CÔTÉ Rouge	COVER side Red	2
	0002010416		CARTER DE CÔTÉ Orange	COVER side Orange	2
	0002010417		CARTER DE CÔTÉ Bleu	COVER side Blue	2
5	0002010273	P506 2216 000	CARTER ARRIÈRE	COVER rear	1
6	0002010063	1429 2224 000	BÉQUILLE	STAY B	1
7	0002010056	1924 2228 000	LEVIER	LEVER	1
8	0002010057	1924 2231 000	LEVIER	LEVER	1
9	0002010058	1429 2231 000	SUPPORT JALON DE PROFONDEUR Rouge 3002	BRACKET Red 3002	1
	0002010418		SUPPORT JALON DE PROFONDEUR Orange 2004	BRACKET Orange 2004	1
	0002010419		SUPPORT JALON DE PROFONDEUR Bleu P301	BRACKET Blue P301	1
10	0002010059	1421 2284 000	CAPUCHON plastique	GRIP	1
11		0521 0106 000	GOUPILLE beta 1,5 x 20	PIN snap 1,5 x 20	1
12	0002010060	0562 0108 035	AXE goupille 8 x 35	PIN clevis 8 x 35	1
13		F050 0110 060	VIS M10 x 60 emb cr	BOLT flange M10 x 60	2
14	0300261001	F301 0110 000	ÉCROU M10 emb cr	NUT flange M10	2
15	0300010609	F050 0106 016	VIS M6 x 16 emb cr	BOLT flange M6 x16	4
16	0300260601	F300 0106 000	ÉCROU M6 emb cr	NUT flange M6	8
17	0300010613	F050 0106 012	VIS M6 x12 emb cr	BOLT flange M6 x12	4
18	0002010320	2786 0213 000	CAPUCHON plastique	GRIP	1
19		A330 0100 800	ÉCROU M8 à oreilles	NUT wing M8	1
20	0002010321	1429 2233 000	RESSORT	SPRING	1
21		A360 0100 802	RONDELLE Grower M8	WASHER Grower M8	1
22	0300010817	F050 0108 040	VIS M8 x 40 emb cr	BOLT flange M8x40	2
23	0300260801	F301 0108 000	ÉCROU M8 emb cr	NUT flange M8	2
24	0002010322	P506 2241 000	PLAQUE DE FIXATION	PLATE	2
25	0002010061	P506 2243 000	BUTÉE CAOUTCHOUC	GROMET	2
26	0002010062	3690 3643 000	MOLETTE M8	BOLT knob M8	1
27	0002010323	1025 3308 100	RESSORT	SPRING	1
28		0350 0150 822	RONDELLE 8 x 22 x 2	WASHER 8 x 22 x 2	1
29	0002010064	1429 2291 000	AXE	ARM	1
30	0002010065	1429 2293 000	SUPPORT	ARM	1
31	0002010066	1429 2294 000	AXE	PIN	1
32	0002010067	1429 2296 000	BARRE	BAR	1
33	0002010068	1429 2298 001	SUPPORT Rouge 3002	BRACKET Red 3002	1
	0002010297		SUPPORT Orange 2004	BRACKET Orange 2004	1
	0002010318		SUPPORT Bleu P301	BRACKET Blue P301	1
34	0300010613	F050 0106 012	VIS M6x12 emb cr	BOLT flange M6x12	3
35	0300260601	F300 0106 000	ÉCROU M6 emb cr	NUT flange M6	3
36		0742 0100 800	ANNEAU Truarc E8	E-RING Truarc E8	2
37		0350 0140 618	RONDELLE 6 x 17 x 1,5	WASHER 6 x 17 x 1,5	1
38	0002010196	0800 0000 600	BILLE 1/4"	BALL 1/4"	1
39	0002010324	2717 2064 000	RESSORT	SPRING	1
40		2740 3129 000	POIGNÉE Capuchon	GRIP	1
41	0002010069	0562 1110 035	AXE goupille 10 x 35	PIN clevis 10 x 35	1
42		0350 0141 022	RONDELLE 10 x 22 x 1,5	WASHER 10 x 22 x 1,5	1
43	0002010337	0521 0108 000	GOUPILLE beta 1,5x28	PIN snap 2x25	2
44	0002010070	1924 2219 000	BÉQUILLE	STAY A	1

ETIQUETTE / OUTIL MARK / TOOL

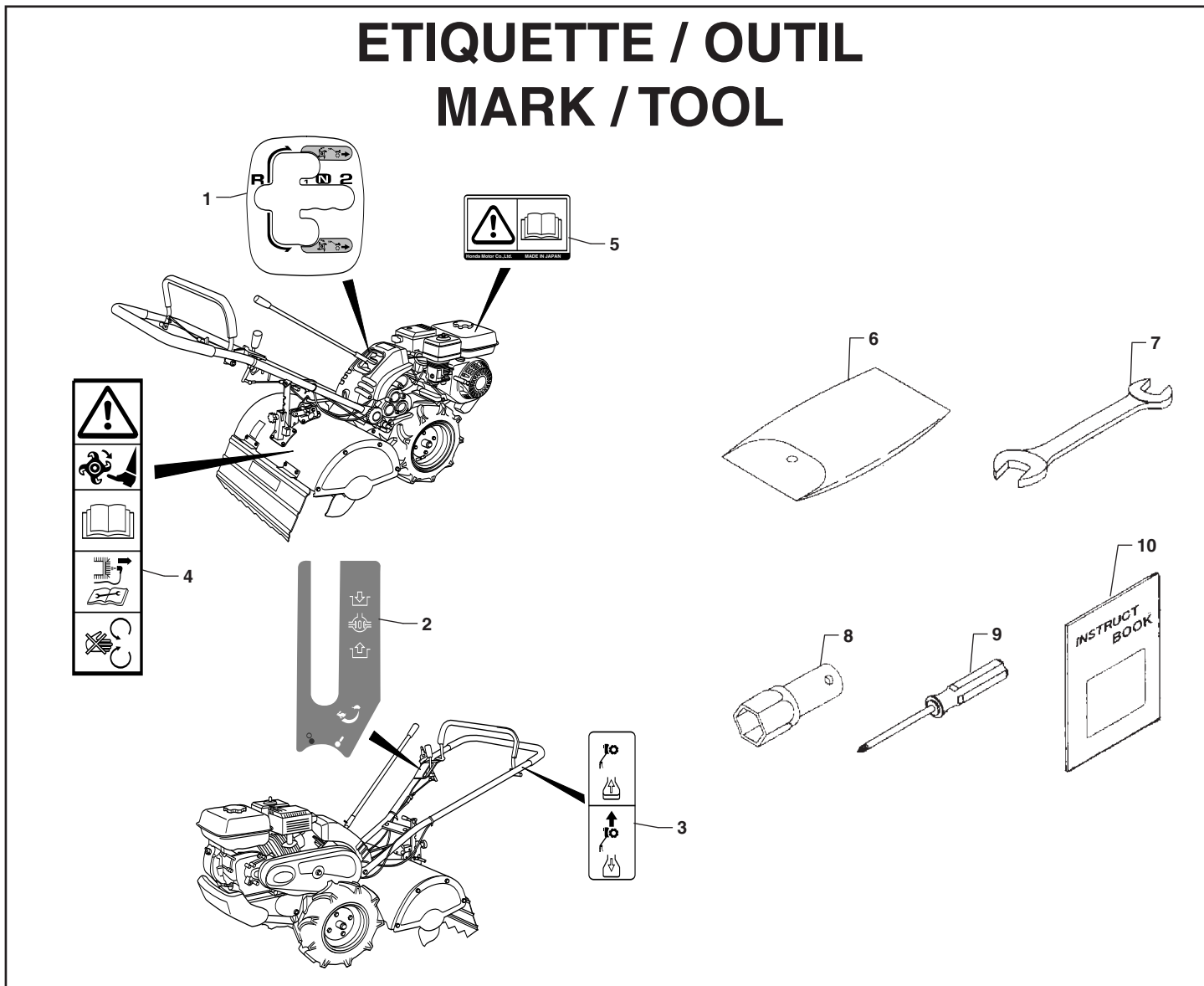

Rep N°	Réf./Ref.	Désignation	Description	Qté Qty
1	0002010016 P506 3010 000	Étiquette levier de vitesse	MARK sign	1
2	0002010017 P506 3011 000	Étiquette embrayage de lame	MARK sign	1
3	0002010018 P506 3012 000	Étiquette marche AV/AR	MARK sign	1
4	0002010019 P506 3014 000	Étiquette attention	LABEL caution	1
5		Étiquette attention	LABEL caution	1
6	1428 2501 000	Sac	BAG	1
7	1428 2502 000	Clef de 10-12	SPANNAR 10X12	1
8	1428 2503 000	Clef	I-BOX WRENCH	1
9	1428 2504 000	Tournevis	DRIVER	1
10	1490 2701 000	Notice pièce de rechange	INSTRUCT BOOK	1