

# TIMBER BEAR

## ILLUSTRATED PARTS LIST

PRO MAC 610 MODELS	SERIAL NUMBER PREFIX	PRO MAC 650 MODELS	SERIAL NUMBER PREFIX
600041A	11-, 12-	600046A	11-
600041B	11-, 12-	600046B	11-
600041C	11-, 12-	600046C	11-
600041D	11-, 12-	600046D	11-
600041E	11-, 12-	600046E	11-
600041F	11-, 12-	600046F	11-
600041G	11-, 12-	600046H	11-
600041H	11-, 12-	600046J	11-
600041J	11-, 12-		
600041K	11-, 12-		
600041L	11-, 12-		
600041N	11-, 12-		
600041O	12-		
600041Q	12-		
600041R	11-, 12-		
600041S	11-, 12-		
600041U	11-, 12-		

# PRO MAC<sup>TM</sup> 610 and 650 Chain Saws

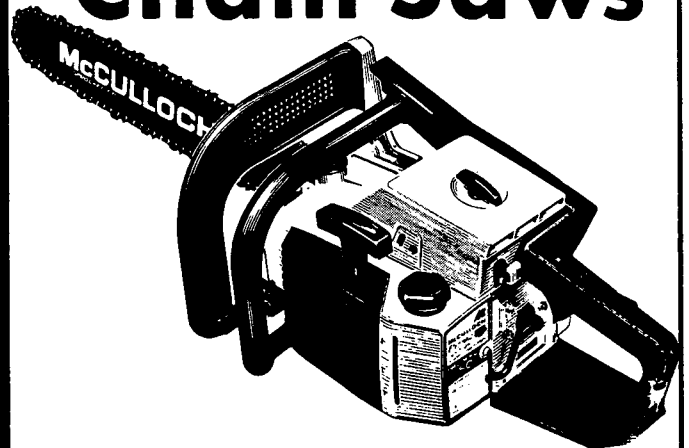

McCulloch chain saws are identified by a model number (in this instance, 600041 ) followed by a suffix letter (A, B, C, etc.) stamped on the identification plate attached to the saw. Suffix letters denote variations in parts or assemblies in the manufacture of the saw.

Part numbers listed in this I.P.L. which have a suffix letter or letters following the description, indicate the part is used only on the model(s) identified by the letter or letters.

Part numbers and descriptions without suffix letter or letters apply to all versions of the chain saw model.

Part numbers which have one or more dots (.) preceding their descriptions may be ordered individually, but they are also included in the kit or assembly whose description begins directly above the dot(s).

Part numbers in this IPL which were not in the previous IPL covering these saws, are indicated by a dash (-) preceding the new part number.

The policy of McCulloch Corporation is one of continual improvement in design, manufacturing and engineering advancement wherever possible to assure still finer two-cycle power tools. Hence, specifications, equipment, colors, design and manufacturer's suggested list prices are subject to change without notice and McCulloch Corporation reserves the right to make such changes without prior notification or obligation to backfit or supply backfit components for units previously shipped from the factory.

### - CONTENTS -

	Page
Figure 1. General . . . . .	2
Figure 2. Carburetor Assembly . . . . .	4
Figure 3. Carburetor Assembly . . . . .	5
Figure 4. Carburetor Assembly . . . . .	6
Figure 5. CHAIN BRAKE Assembly . . . . .	7
Figure 6. Fan Housing & Fuel Tank Asys . . . . .	7
Figure 7. Powerhead and Oiler Assemblies . . . . .	8
Tools and Accessories . . . . .	10
Service Specifications . . . . .	10

(This IPL supercedes and replaces IPL, P/N 93716)

December 1984



© U.S.A. - McCulloch Corporation, 1984

Printed in U.S.A.

215036-R3-E

Figure 1. General

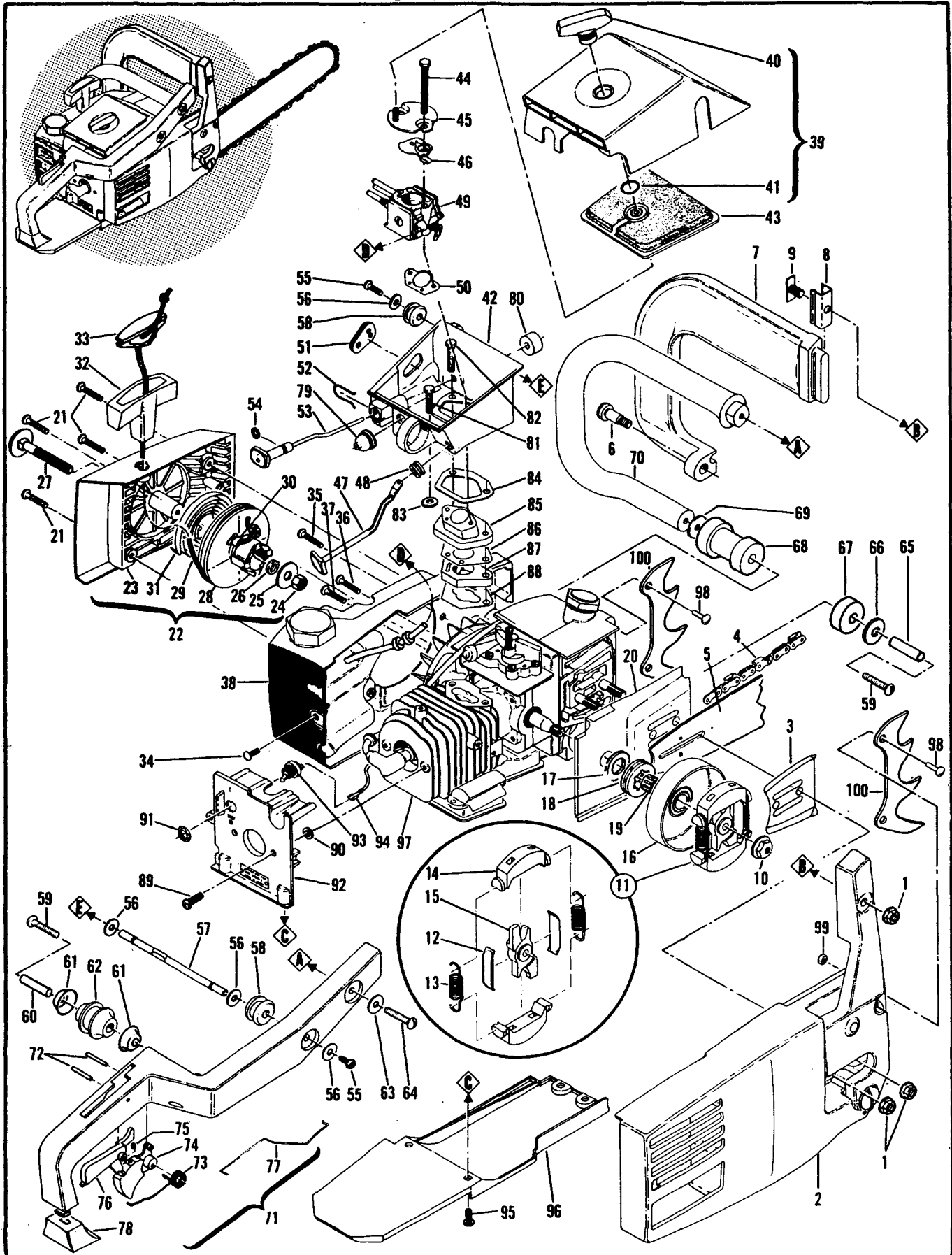
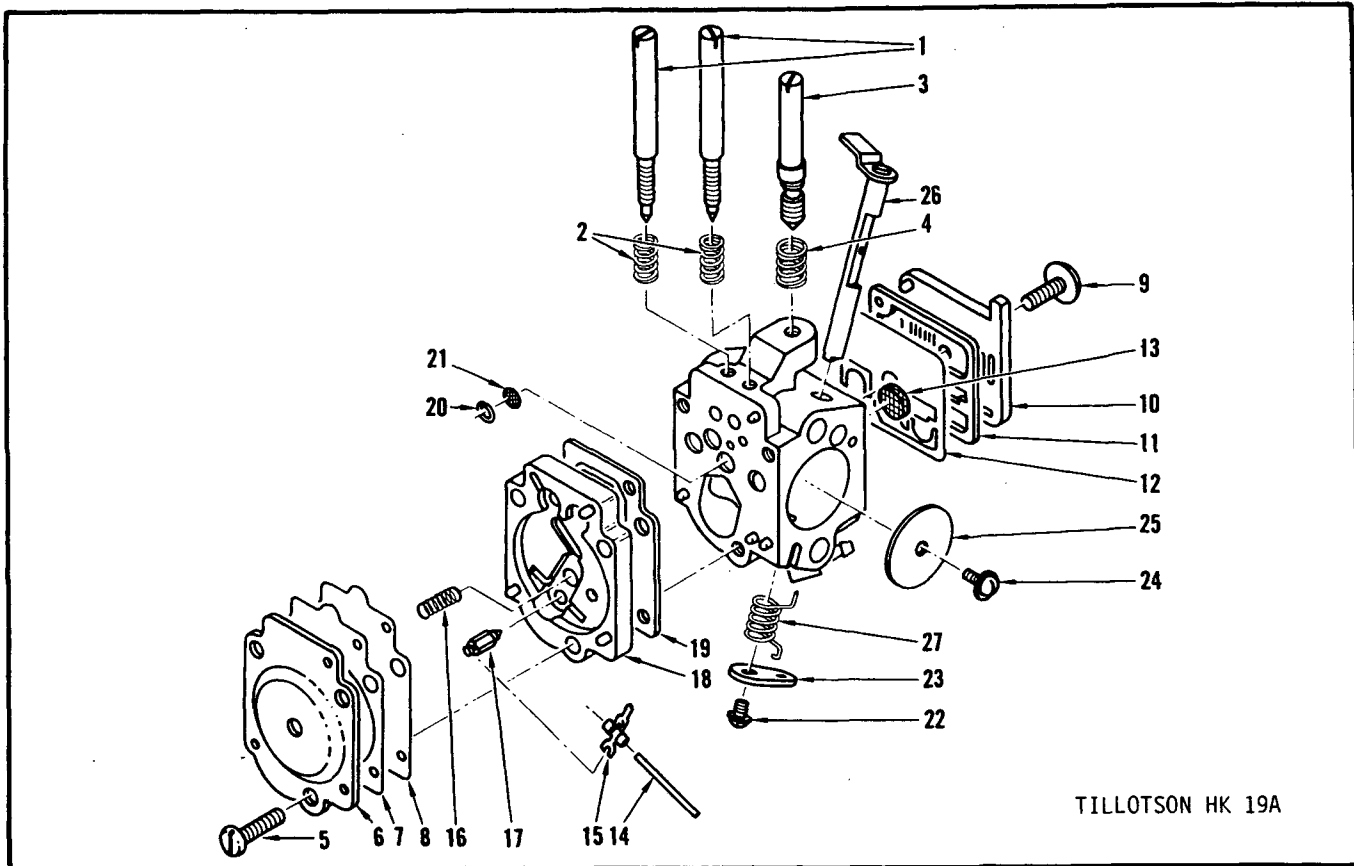

Figure 1. General

ITEM NO.	PART NUMBER	DESCRIPTION	UNITS PER ASY.	ITEM NO.	PART NUMBER	DESCRIPTION	UNITS PER ASY.
1	213169	Nut - HEX Flange	3	48	93261	Grommet - Choke	1
2		CHAIN BRAKE ASY. (FIGURE 5)		49		Carburetor Asys. (Fig. 2,3,4)	
3	64325	Plate - Bar Protector	1	50	91924	Gasket - Carburetor	1
4		Chain Assembly		51	91995A	Grommet - Carburetor Needle	1
5		Bar Assembly		52	93458	Clip - Oiler Button	1
6	95671	Screw - Brake Arm	1	53	92067A	Button/Rod Assembly - Oiler	1
7	91989B	Arm - Brake Actuator	1	54	105614	"O" Ring	1
8	93721	Channel - Brake Arm	1	55	215266	Screw - Pan M5 Special	2
9	93746	Stud - Brake	1	56	110990	Washer	4
10	92457	Nut - Hex Flange M10 x 1.25	1	57	93252A	Strut - Handle	1
11	214301	Clutch Assembly	1	58	93253	Grommet - Strut	2
12	64583	. Retainer - Clutch Shoe	2	59	111015	Screw - Pan Head 1/4-14 x 2.5	2
13	83223	. Spring - Clutch	2	60	92071	Spacer	1
14	67233	. Kit - Clutch Shoe	1	61	92066	Cup - Isolator	2
15	214300	. Rotor - Clutch	1	62	92065	④ Isolator	1
16	214200	① Drum/Spkt. Assembly (Spur)	1	63	102115	Washer - Plain	1
17	86958	Washer - Shim	1	64	111014	Screw - Pan Hd 1/4-14 x 1.75	1
16	95165	② Drum/Spkt. Assembly (Spur)	1	65	92071	Spacer	1
17	86958	② . Washer - Shim	1	66	111027	Washer - Plain	1
18	86344	② . Sprocket - 7T .375P	1	67	93913	④ Isolator	1
16	95166	③ Drum/Spkt. Asy. - 7T .375P	1	67	94847	⑤ Isolator	2
17	86958	③ . Washer - Shim	1	68	94140	④ Isolator	1
18	86145	③ . Sprocket - 7T .375P	1	69	111027	Washer - Plain	1
19	215720	Bearing - Needle	1	70	91951	Frame	1
20	92354	Jacket - Cylinder	1	71	94255	Handle/Boot Assembly	1
21	120081	Screw - Pan Hd M4 x 16 (SEMS)	4	72	110994	. Pin - Roll	2
22	219159	Starter Assembly	1	73	93771	. Spring - Trigger	1
23	95353	. Kit - Starter Housing	1	74	93538A	. Trigger	1
24	111038	. . Nut - 1/4-20	1	75	111013	. Screw - Set	1
25	95401	. . Washer - Starter	1	76	91955	. Release - Trigger	1
26	216589	. . Spacer - Starter	1	77	214504	. Rod - Throttle	1
27	215848	. . Step Bolt - Starter	1	78	93459	. Boot - Handle	1
28	216758	. Drum Assembly - Starter	1	79	69597	Boot - Control Rod	1
29	87670	. . Rope - Starter	1	80	92161	Seal - Air Box	1
30	217730	. . Bushing - Rope	1	81	120037	Screw - Hx Hd M5 x 25 (SEMS)	1
31	87680	. Spring - Starter Rewind	1	82	120039	Screw - Hx Hd M5 x 30 (SEMS)	2
32	93137	Starter Handle	1	83	93460	Washer - Insulator	1
33	214699	Insert Handle	1	84	94018	Gasket - Air Box	1
34	120002	Screw - Pan Hd M5 x 14	1	85	94017A	Insulator - Carburetor	1
35	93232	Screw - Fan Housing (M5 x 40)	1	86	91933	Gasket - Air Box	1
36	93233	Screw - Fan Housing (M5 x 35)	1	87	91934	Insulator - air Box	1
37	93234	Screw - Fan Housing (M5 x 30)	1	88	92038	Gasket - Insulator	1
38		Fan Housing & Fuel Tank Asy. (Figure 6)		89	120037	Screw - Hx Hd M5 x 25 (SEMS)	2
39	217651	Cover Asy. - Air Cleaner	1	90	93460	Washer - Insulator	1
40	91991	. Knob - Air Cleaner Cover	1	91	104810	Nut - Hx 15/32-32	1
41	110565	. Ring - Retaining	1	92	92004	Shroud - Cylinder	1
42	95215	Kit - Air Box	1	93	93890	Switch - Ignition	1
43	214226	. Filter - Air	1	94	92466	Wire Assembly - Switch	1
44	120004	Screw - Hx Hd M5 x 56	2	95	120002	Screw - Pan Hd M5 x 14	4
45	91938	Bracket Asy. - Air Cleaner	1	96	214670	Shroud - Bottom	1
	94482	Choke & Rod Kit	1	97		Powerhead & Oiler Asys. (Fig. 4)	
46	94151	. Choke Carburetor	1	98	120002	⑥ Screw - Pan Hd M5 x 14	4
47	94171	. Rod - Choke	1	99	120044	⑥ Nut - Hx M5 Lock	2
				100	93668	⑥ Spike	2

- ① Used on PM 610 models with serial number prefix 12-.
- ② Used on all models with serial number prefix 11- except those with suffix letter A.
- ③ Used on models with serial number prefix 11- and suffix letter A.
- ④ PM 600 models with suffix letter J will use a second Isolator, P/N 94847, in place of Isolator, P/N 94140 (Item 68).
- ⑤ Used on PM 650 models with suffix letter J.
- ⑥ Optional equipment.

Figure 2. Carburetor Assembly



ITEM NO.	PART NUMBER	DESCRIPTION	UNITS PER ASY.
	93739 *	Carburetor - Tillotson HK 19A (PM 610)	
1	94797	. Needle - Hi Speed + Idle	2
2	- - ①	. Spring - Needle Adjustment	2
3	94798 ①	. Screw - Idle Speed	1
4	94700 ①	. Spring - Idle Speed Screw	1
5	94789	. Screw - Diaphragm Cover	3
6	94788	. Cover - Diaphragm	1
7	94787 ①	. Diaphragm	1
8	- - ①	. Gasket - Diaphragm	1
9	94793	. Screw - Pump Cover	1
10	94792	. Cover - Fuel Pump	1
11	- - ①	. Gasket - Fuel Pump	1
12	94794 ①	. Diaphragm - Fuel Pump	1

ITEM NO.	PART NUMBER	DESCRIPTION	UNITS PER ASY.
13	94796	. Screen - Fuel Strainer	1
14	- - ①	. Pin - Inlet Lever	1
15	94800 ①	. Lever - Inlet	1
16	- - ①	. Spring - Inlet	1
17	94802	. Needle - Inlet	1
18	- -	. Body - Module	1
19	- - ①	. Gasket - Module Metering	1
20	94786	. Ring - Retaining	1
21	- -	. Screen - Body Channel	1
22	94807 ①	. Screw - Throttle Lever Ret.	1
23	- -	. Lever - Throttle	1
24	94811	. Screw-Throttle Shutter Ret.	1
25	94810	. Shutter - Throttle	1
26	94808	. Shaft Assembly - Throttle	1
27	94809 ①	. Spring-Throttle Shaft Ret.	1

\* One of three carburetors used alternately on PM 610 Models.  
Identify carburetor before ordering service repair parts.

① Contained in Repair Kit, P/N 94813.

Figure 3. Carburetor Assemblies

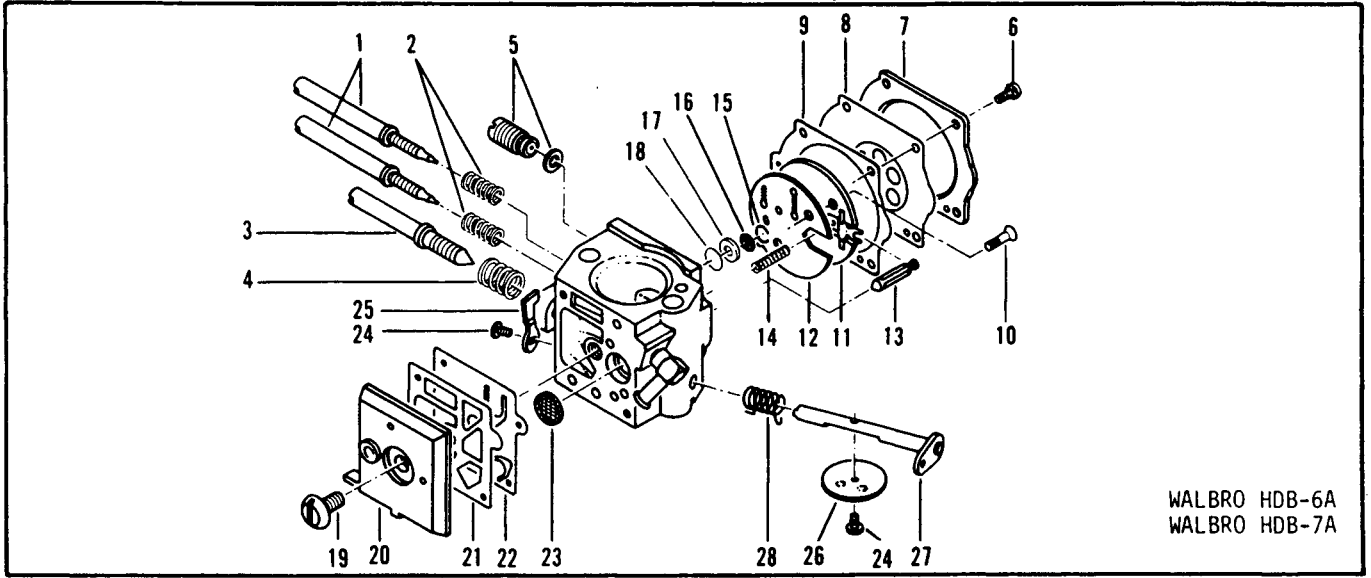

ITEM NO.	PART NUMBER	DESCRIPTION	UNITS PER ASY.
	95763A *	Carburetor - Walbro HDB -6A (PM 610)	
	95631	Carburetor - Walbro HDB-7A (PM 650)	
1	- - ①	. Needle - Hi Speed & Idle	2
2	- - ①	. Spring - Needle Adjustment	2
3	- -	. Screw - Idle	1
4	- -	. Spring - Idle Adjustment	1
5	- -	. Governor Asy. (HDB-7A Only)	1
6	- -	. Screw - Metering Cover	4
7	- -	. Cover - Metering Diaphragm	1
8	- - ① ②	. Diaphragm Asy. - Metering	1
9	- - ① ②	. Gasket - Metering Diaphragm	1
10	- -	. Screw - Circuit Plate	1
11	- - ①	. Plate Assembly - Circuit	1
12	- - ① ②	. Gasket - Circuit Plate	1

ITEM NO.	PART NUMBER	DESCRIPTION	UNITS PER ASY.
13	- - ① ②	. Valve - Inlet Needle	1
14	- - ① ②	. Spring - Metering Lever	1
15	- - ① ②	. Ring - Screen Retaining	1
16	- - ① ②	. Screen - Check Valve	1
17	- - ①	. Retainer - Check Valve	1
18	- -	. Valve - Check	1
19	- -	. Screw - Fuel Pump Cover	1
20	- -	. Cover - Fuel Pump	1
21	- - ① ②	. Gasket - Fuel Pump	1
22	- - ① ②	. Diaphragm - Fuel Pump	1
23	- - ① ②	. Screen - Inlet	1
24	- -	. Screw - Valve	2
25	- -	. Stop - Throttle	1
26	- -	. Valve - Throttle	1
27	- -	. Shaft Assembly - Throttle	1
28	- - ①	. Spring Throttle Return	1

\* One of three carburetors used alternately on PM 610 models. Identify carburetor before ordering service repair parts.

① Contained in Major Repair Kit, P/N 217075.

② Contained in Minor Repair Kit, P/N 217077.

NOTE: Items are listed for identification and disassembly sequence purposes and ONLY those items included in the Major and Minor Repair Kits are available as service replacement parts.

Figure 4. Carburetor Assembly.

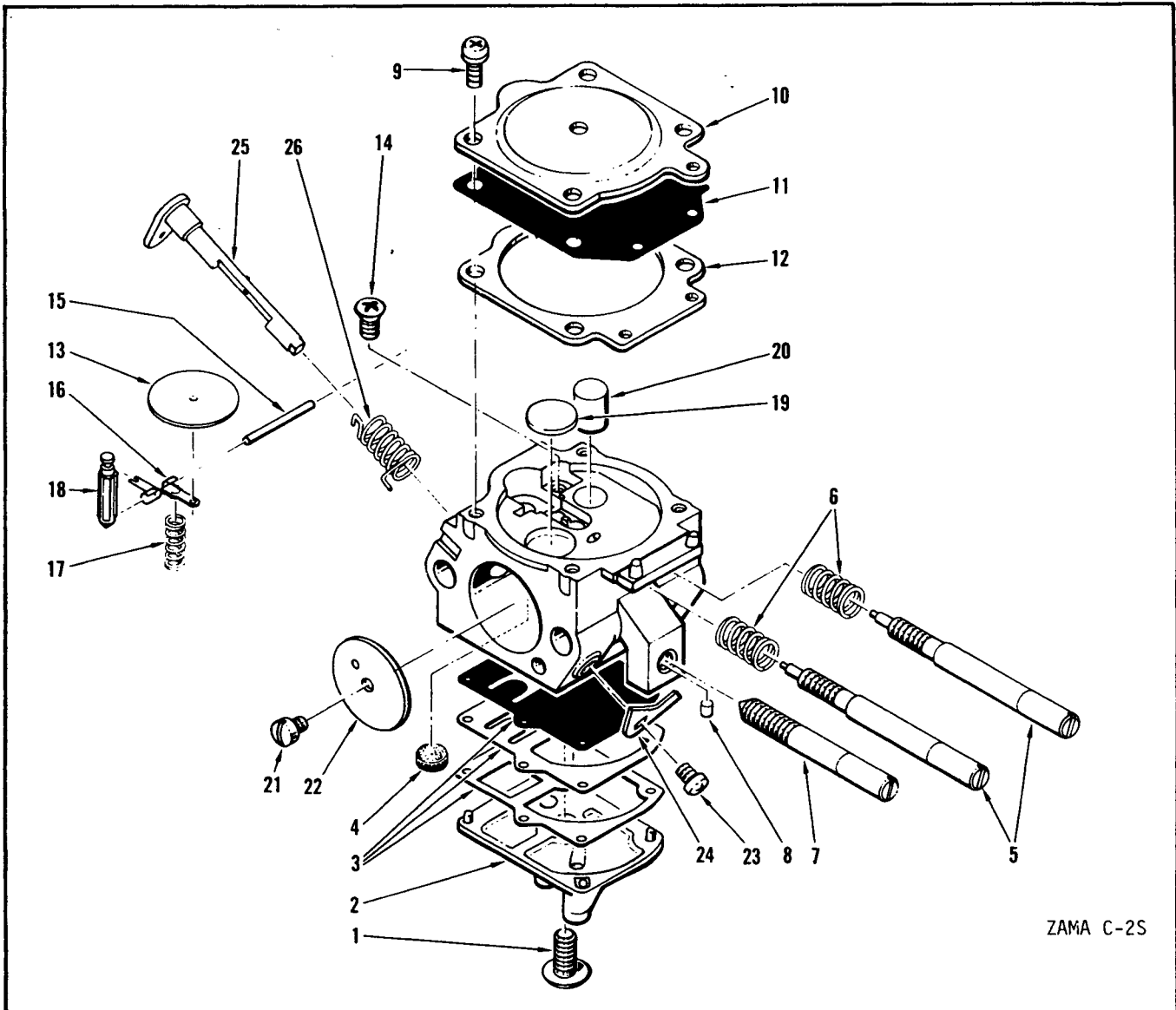

ZAMA C-2S

ITEM NO.	PART NUMBER	DESCRIPTION	UNITS PER ASY.
	95763	* Carburetor Asy. (Zama C-2S)	
1	501311	. Screw - Pump Cover	1
2	214954	. Cover - Pump	1
3	214953	① . Kit - Pump Diaphragm	1
4	91820	① . Screen - Filter	1
5	- -	① . Screw - Adjustment	2
6	- -	① . Spring - Adjustment Screw	2
7	- -	. Screw - Throttle Adjustment	1
8	- -	. Piece - Friction	1
9	93945	. Screw - Diaphragm Cover	4
10	214945	. Cap	1
11	- -	① . Diaphragm - Main	1
12	- -	① . Gasket - Main	1
13	- -	① . Disk	1

ITEM NO.	PART NUMBER	DESCRIPTION	UNITS PER ASY.
14	91814	① . Screw Pin Lever	1
15	93942	① . Pin - Arm	1
16	- -	① . Arm - Needle Valve	1
17	- -	① . Spring - Arm	1
18	- -	① . Valve - Needle	1
19	93951	. Plug - Welsh	1
20	- -	① . Orifice - Main Fuel	1
21	- -	. Screw - Plate	1
22	- -	. Valve - Throttle	1
23	- -	. Screw	1
24	- -	. Lever - Throttle Adjustment	1
25	- -	. Shaft Assembly - Throttle	1
26	- -	. Spring - Throttle Return	1

\* One of three carburetors used alternately on PM 610 models.  
Identify carburetor before ordering service repair parts.

① Contained in Repair Kit, P/N 214959.

NOTE: Items are listed for identification and disassembly sequence purposes and only those items with part numbers or items contained included in the repair kit are available as service parts.

Figure 5. CHAIN BRAKE Assembly

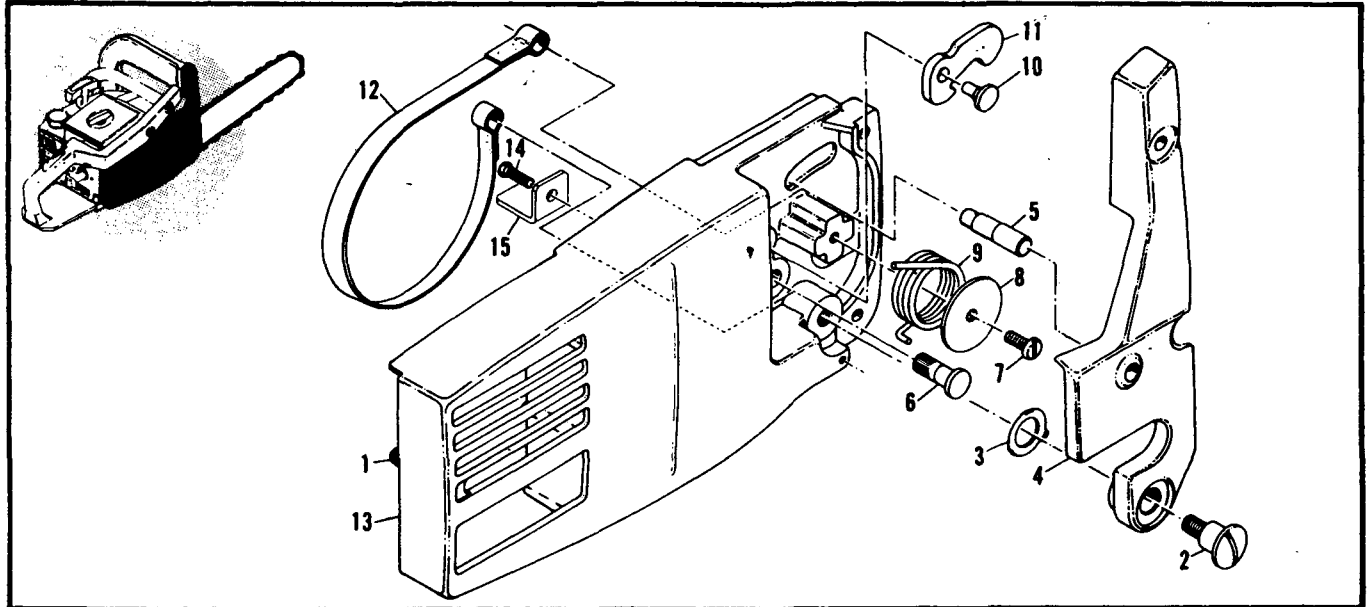

ITEM NO.	PART NUMBER	DESCRIPTION	UNITS PER ASY.
	217007	CHAIN BRAKE Assembly	1
1	92086	. Snubber - Brake Housing	1
2	216693	. Screw - Pivot	1
3	92216	. Washer - Special	1
4	217000	. Lever - Brake Actuator	1
5	214367	. Pin - Assembly Roller	1
6	93082	. Pin - Band Anchor	1
7	120019	. Screw - Hx Hd M5 x 13	1

ITEM NO.	PART NUMBER	DESCRIPTION	UNITS PER ASY.
8	92134	. Retainer - Spring	1
9	92135	. Spring - Actuating	1
10	94144	. Pivot - Latch	1
11	94150	. Latch Brake	1
12	93081	. Band - Brake	1
13	-216317	. Housing - Brake	1
14	120002	Screw - Pan Hd M5 x 14	1
15	92178	Stop - Chain	1

Figure 6. Fan Housing & Fuel Tank Assemblies

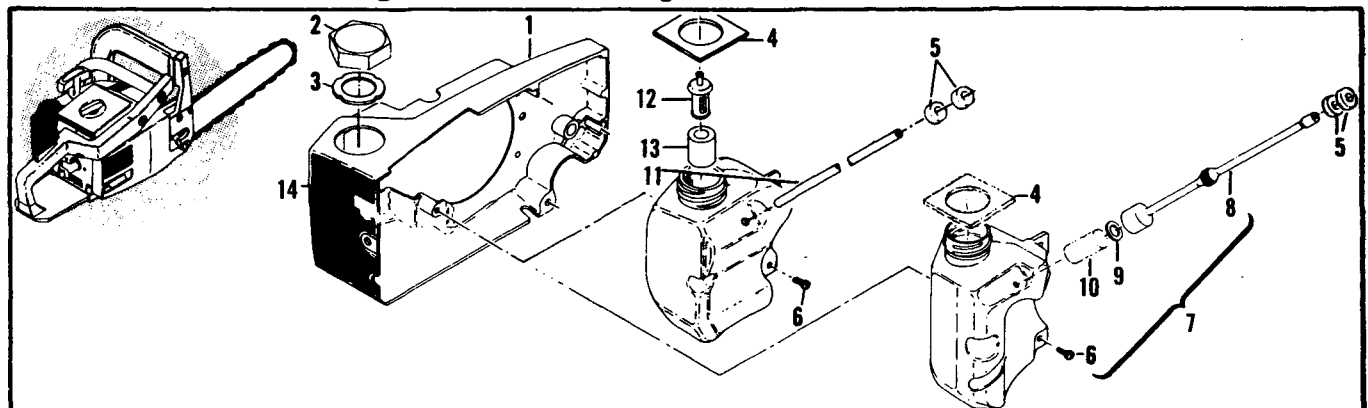

ITEM NO.	PART NUMBER	DESCRIPTION	UNITS PER ASY.
1	216154	Housing Fan	1
2	216157	Cap - Fuel (vented)	1
3	94707	. Gasket - Fuel cap	1
4	93251	Seal - Fuel Vent	1
5	92161	Seal - Air Box	2
6	120068	Screw - Pan hd M4 x 12 (SEMS)	2
7	94901	① Fuel Tank Assembly	1
8	94899	. Hose Assembly - Fuel	1
9	100440	. . Washer - 5/16	1

ITEM NO.	PART NUMBER	DESCRIPTION	UNITS PER ASY.
10	63932	. . Filter - Fuel	1
11	91994	① Hose - Fuel	1
12	215714	① Pickup Assembly - Fuel	1
13	61159	① Filter - Fuel Pickup	1
14	95184	Plate - Name (PM 610)	1
14	95185	Plate - Name (PM 650)	1
14	95196	Plate - Name, French (PM 610)	1
14	95194	Plate - Name, French (PM 650)	1

① If saw was originally equipped with Fuel Tank Assembly, P/N 93478, order individual parts as indicated. For complete replacement of Fuel Tank Assembly order P/N 94901.

**PRO MAC™  
610/650**

**Figure 7. Powerhead & Oiler Assemblies**

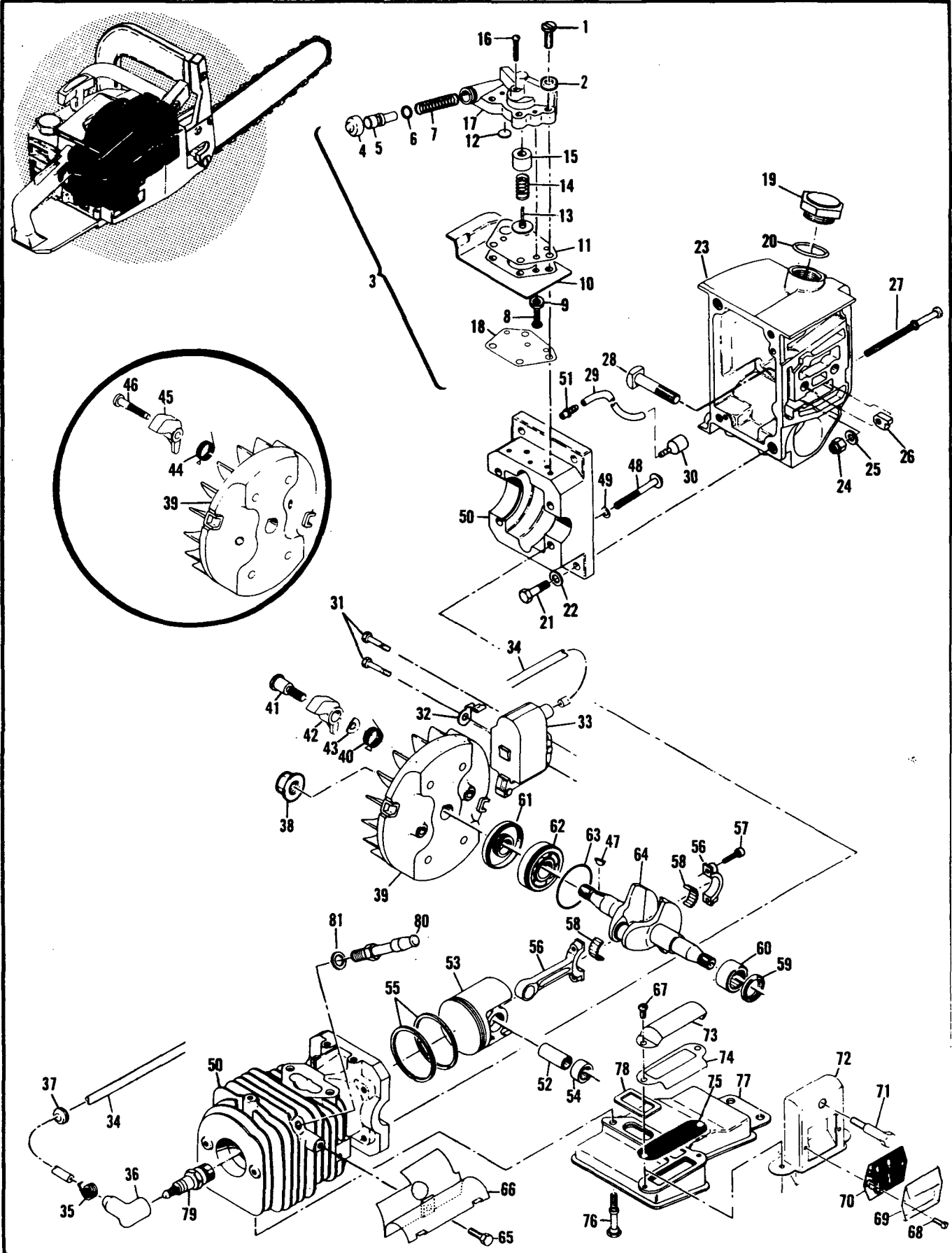



Figure 7. Powerhead & Oiler Assemblies.

ITEM NO.	PART NUMBER	DESCRIPTION	UNITS PER ASY.	ITEM NO.	PART NUMBER	DESCRIPTION	UNITS PER ASY.
1	120036	Screw - Pan Hd M4 x 25 (SEMS)	4	43	213253	. Washer - Spring	2
2	67177	Washer - Insulating	4	44	93144 ①	Spring - Starter Pawl	2
3	217208	Pump Assembly - Pulse Oiler	1	45	93145 ①	Pawl - Starter	2
4	-215151	. Cap - Oil Pump	1	46	93146 ①	Pin - Starter Pawl	2
5	93933	. Plunger - Oil Pump	1	47	100106	Key - Woodruff	1
6	105614	. "O" Ring	1	48	62106	Screw - Wsh Hd 12-24 x 1-3/4	4
7	66687	. Spring - Plunger	1	49	111025	Washer - Sealing	4
8	110706	. Screw - Pan Hd 8-18 x .50	3	50	94304	Cyl/C'Case Assembly (PM 610)	1
9	216354	. Gasket Washer	1	51	92096	. Nipple - Oil Line	1
10	217218	. Cover - Diaphragm	1	50	94536	Cyl/C'Case Assembly (PM 610)	1
11	216992	. Diaphragm - Oiler	1	51	92096	. Nipple - Oil Line	1
12	217217	. Valve - Oiler	1	52	87710	Pin - Piston	1
13	91945	. Piston Assembly - Pulse	1	53	94130	Piston Assembly	1
14	94322	. Spring - Return	1	54	111021	. Bearing - Needle	2
15	91944	. Sleeve - Oil Pump	1	55	94132	. Ring Set - Piston	1
16	120092	. Screw - Pan Hd M3.5 x 22	1	56	85352	Rod Assembly Connecting	1
17	216991	. Body Assembly - Oil Pump	1	57	61627A	. Screw - Connecting Rod	1
18	91950	Gasket - Oil Pump	1	58	63225	Roller - Needle (Set of 20)	1
19	216052	Cap Assembly - Oil	1	59	110260	Seal - Oil .625ID x .875	1
20	101148	"O" Ring	1	60	104357	. Bearing - Needle	1
21	120006	Screw - Hs Hd M6.3 x 24	4	61	67906	Seal - Oil	1
22	100004	Washer - Plain	4	62	67905	Bearing Ball	1
23	218583	Tank Assembly - Oil	1	63	63464	Ring - Snap	1
24	110950	. Nut - Lock	1	64	217041	Crankshaft	1
25	102115	. Washer - Plain	1	65	102762 ②	Screw - Hx Hd 10-24 x 1/2	1
26	91982	. Nut - Bar Adjustment	1	66	95439 ②	Deflector Assembly - Exhaust	1
27	94362	. Screw - Bar Adjustment	1	67	120038	Screw - Pan M4 x 8	2
28	92459	. Bolt - Bar	2	68	216627 ③	Screw - Pan 6-32 x .25 Tap	2
29	92616	Hose - Oil Pickup	1	69	93482 ③	Cover - Muffler Chamber	1
30	92465	Pickup - Oil	1	70	93605 ③	Screen - Muffler	1
31	120037	Screw - Hx M5 x 25 (SEMS)	2	71	93897 ③	Screw - Muffler	1
32	84686A	Wire Assembly	1	72	216254 ③	Chamber Assembly - Muffler	1
33	95553	Ignition Assembly-Electronic	1	73	93604 ④	Outlet - Muffler	1
34	95270	. Wire Assembly - Spark Plug	1	74	93481 ④	Plate - Deflector	1
35	102556	. . Connector - Spark Plug	1	75	214205 ②④	Screen - Muffler	1
36	95266	. . Boot - Spark Plug	1	76	92458	Screw - Muffler	1
37	110995	. Grommet - Spark Plug Wire	1	77	93603	Body/Cover Assembly - Muffler	1
38	94500	Nut - Hx Flange M10	1	78	84007	Gasket - Muffler	1
39	216739 ①	Flywheel/Pawl Assembly	1	79	93017 ⑤	Spark Plug - CH - RDJ6H	1
40	93144	. Spring - Starter Pawl	2	80	214304 ⑦	Valve - DSP	1
41	95362	. Screw - Starter Pawl	2	81	214765 ⑦	Washer - Valve	1
42	95361	. Pawl - Starter	2				

- ① If saw was originally equipped with Flywheel/Pawl Assembly, P/N 94183, order service replacement parts as indicated. For complete Flywheel/Pawl Assembly, order P/N 216739.
- ② Used on PM 610 models with suffix letters C, F, G, L, N, R and U. Also, PM 650 models with suffix letter D.
- ③ Used on PM 610 and PM 650 models with suffix letters A, B, E, H and J.
- ④ Used on PM 610 models with suffix letter K.
- ⑤ Used on PM 610 models with suffix letters A, C, F, G, H, J, K, L, N, R, and U. Also, PM 650 models with suffix letters A, D, H and J.
- ⑥ Used on PM 610 and PM 650 models with suffix letters B and E.
- ⑦ Used on PM 650 models only.

**PRO MAC  
610/650**

**Tools & Accessories.**

PART NUMBER	DESCRIPTION	PART NUMBER	DESCRIPTION	PART NUMBER	DESCRIPTION
215432	Pressure Test Tool	94962	Scrench	95159	Allen Wrench - 5mm
63137	Adaptor - Exhaust	214195	Gun - Lube (Disposable)	69794	Locquic
94415	Adaptor - Intake	214194	Gun - Lube (Deluxe)	110083	R.T.V. Sealant
110761	Plug - D.S.P.	85702	Lubricant - Custom, 6 oz. Can	94121	Kit - Carrying Case, 20"
501334	Ignition Tester			214203	. Scabbard, 20"
84223	Kit - Piston Tools	85703	Lubricant - Custom, 6 oz. Cans, 1 6-pak	94367	Kit - Carrying Case, 16"
501222	Piston Stop Tool			92896	. Scabbard, 16"
95218	Air Filter - Felt			214208	Kit - Spike

**BAR and CHAIN COMBINATIONS**

PART NUMBER	DESCRIPTION
214237	Bar - 16" Sprocket Tip
94074	Bar - 16" Speed Mac
89502	Bar - 16" Mac 10
218061N	Chain - 16" PMR 370G
89974N	Chain - 16" SPR 370G
88167N	Chain - 16" PM 370G
217025	Bar - 18" Sprocket Tip
218062N	Chain - 18" PMR 370G
214238	Bar - 20" Sprocket Tip
93778	Bar - 20" Speed Mac
89503	Bar - 20" Mac 10
89978N	Chain 20" SPR 370G
89979N	Chain - 20" SPR 370G

PART NUMBER	DESCRIPTION
88173N	Chain - 20" PM 370G
86846	Bar - 24" Speed Mac
89504	Bar - 24" Mac 10
88175N	Chain - 24" PM 370G
89981N	Chain - 24" SPR 370G
93551N	Chain - 24" PM 370G
89982N	Chain - 24" SPR 370G
86847	Bar - 28" Speed Mac
89505	Bar - 28" Mac 10
89984N	Chain - 28" SPR 370G
93552N	Chain - 28" PM 370G
89985N	Chain - 28" SPR 370G

**Service Specifications**

SPARK PLUG GAP. . . . .	.025 inch (.63mm)
LAMINATION GAP. . . . .	.011 to .015 inch (.28 to .38mm)
TIMING. . . . .	26 BTDC
CLUTCH ENGAGEMENT SPEED . . . . .	2800 to 3000 RPM
IDLE SPEED. . . . .	1800 to 2000 RPM
FUEL TYPE . . . . .	Regular Grade Leaded
FUEL/OIL MIXTURE: . . . . .	40:1 w/McCulloch Oil
	20:1 SAE Two Cycle
FUEL TANK CAPACITY. . . . .	17.3 ounces (510 cc)
DISPLACEMENT. . . . .	60 cc (3.7 cu. in.)
BORE and STROKE . . . . .	4.7mm x 35 mm (1.9 in. x 1.5 in.)
WEIGHT: PM 610. . . . .	14.7 pounds (6.65kg)
PM 650. . . . .	14.8 pounds (6.70kg)

**Torque Values**

CONNECTING ROD SCREWS . . . . .	65 yo 70 pound x inches (7.3 to 7.9 N.m)
CLUTCH NUT. . . . .	160 to 170 pound x inches (18.1 to 19.2 N.m.)
FLYWHEEL NUT. . . . .	265 to 325 pound x inches (29.9 to 36.7 N.m.)