

Tecumseh Quick Reference Service Information

Covers Engine and Transmission Product



Introduction

This booklet contains the quick reference and basic troubleshooting information previously found on Tecumseh wall charts and in the Technician's Handbooks.

This booklet is designed to be used as a work bench quick reference guide when servicing Tecumseh engines and motion drive systems.

Technician's Note:

Tecumseh engines are manufactured to meet EPA and CARB standards. As a technician, it is unlawful to re-calibrate or replace a fuel nozzle or jet (bowl nut) with a part from any other carburetor that was not originally designed for that engine. All speed adjustments must remain within the limits that are specified for each engine and are not to exceed the maximum. This can only be deviated from if specifically approved by Tecumseh Products, EPA and CARB.

Note: Torque specifications listed should not be confused with the torque value observed on engines which have been run.

The Torque specifications take relaxation into account so sufficient clamping force exists after an engine has reached operating temperature.

Torques listed are intended to cover highly critical areas. More extensive torques are found in the respective repair manual.

Torque Specifications

TWO-CYCLE ENGINE SERIES

840 - 850 TWO-CYCLE ENGINE SERIES

Location	Inch lbs. Torque	Nm	Engine Designation			
			TVS	TVXL	HSK	HXL
Crankcase to Cylinder	120-204	13.5-23	●	●	●	●
Flywheel Nut	360-420	41-47.5	●	●	●	●
Adapter Plate to Cylinder	160-220	18-25	●	●		

TC TWO-CYCLE ENGINE SERIES

Location	Inch lbs. Torque	Nm	Engine Designation		
			TC200	TC300	TCH200/ 300
Cylinder to Crankcase	80-95	9-11	●	●	●
Crankcase Cover to Crankcase	70-100	8-11	●	●	●
Flywheel Nut	190-250	21.5-28.5	●	●	●

TWO-CYCLE ENGINE SERIES (AV520/600, TVS600, AH520, AH/HSK600)

Location	Inch lbs. Torque	Nm	Engine Designation			
			AV520/600	TVS600	AH/HSK600	AH520
Connecting Rod	40-50	4.5-5.5	●	●	●	●
Housing Base to Cylinder	80-120	9-13.5	●	●	●	●
Cylinder Head to Cylinder	100-140	11-16	●	●	●	●
Flywheel Nut AV Industrial (Point Ignition) (670 Series AV 520 and All AV 600)	216-300	24.5-34	●			●
Flywheel Nut (C.D. Ignition)	264-324	30-36.5	●	●	●	●

Two Cycle Troubleshooting

As an aid in troubleshooting any piece of equipment, interview the customer, and review conditions and symptoms of the problem. Examine exterior for clues: leaks, excessive dirt, damaged or new parts.

FUEL SYSTEM

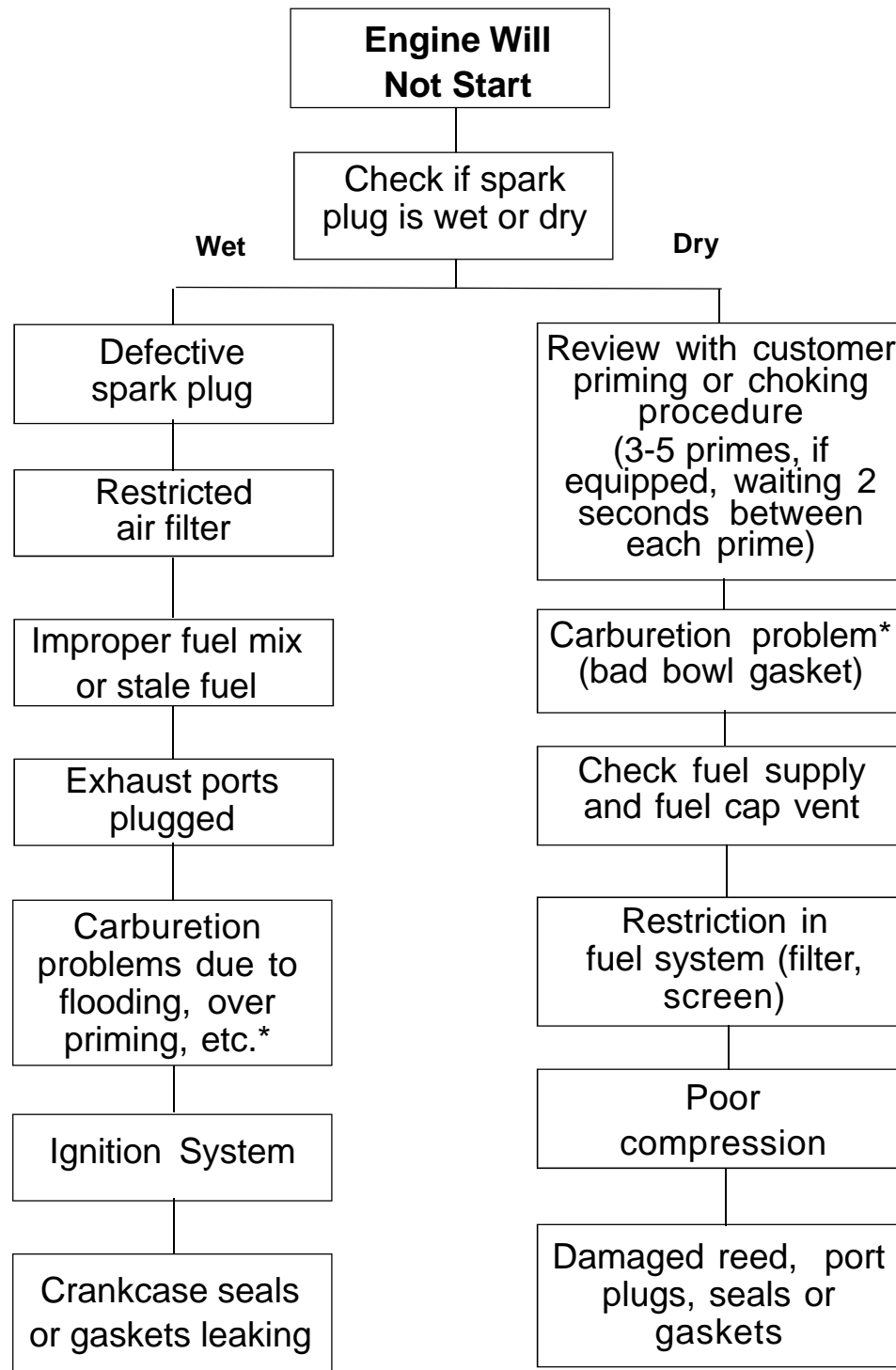

NOTE: Refer to Technician's Handbook for a more detailed list of remedies.

*Carburetor Troubleshooting use Technician's Handbook or Carburetor Troubleshooting Booklet, Form No. 695907. Video No. 695015.

(CONTINUED ON NEXT PAGE)

Two Cycle Troubleshooting - *continued*

IGNITION SYSTEM

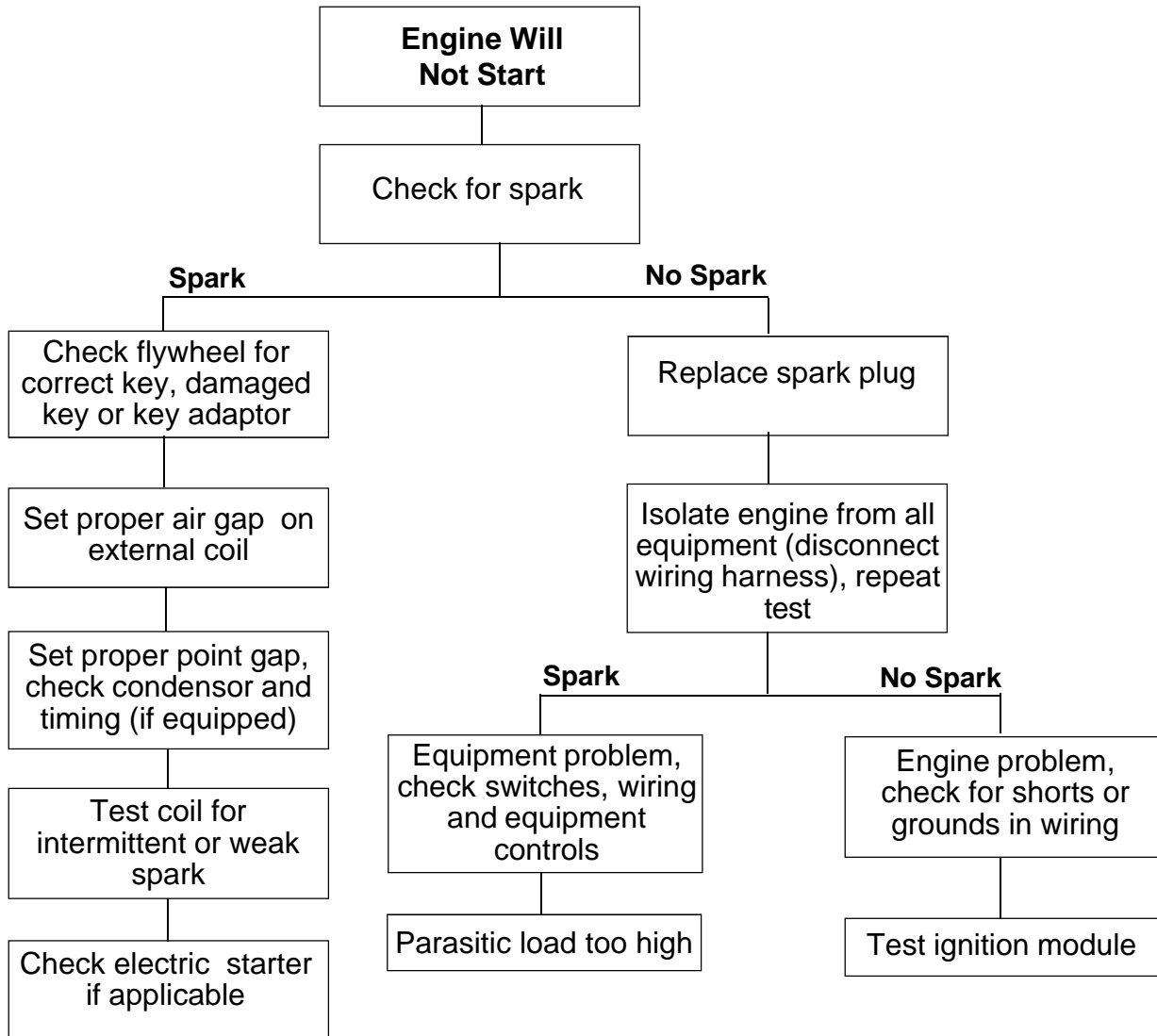

NOTE: Refer to Technician's Handbook for a more detailed list of remedies.

Note: Torque specifications listed should not be confused with the torque value observed on engines which have been run.

The Torque specifications take relaxation into account so sufficient clamping force exists after an engine has reached operating temperature.

Torques listed are intended to cover highly critical areas. More extensive torques are found in the respective repair manual.

Torque Specifications

FOUR-CYCLE LIGHT FRAME ENGINE SERIES

(TVS, TNT, ECV, LAV, LEV, H, HS, OHH, OVRM and VLV)

Location	Inch lbs. Torque	Nm	Engine Designation										
			TVS	TNT	ECV	LAV	H/HSK	HS/HSSK	OVRM	VLV	LEV	OHH	
Rocker Arm Stud Lock Nut	100-140	11-16											
Connecting Rod	95-110	11-12.5	•	•	•	•	•	•	•	•	•	•	•
Cylinder Head	160-210	18-24	•	•	•	•				•			
Cylinder Head	220-240	25-27								•			•
Cylinder Head	180-220	20.5-25									•		
Mounting Flange or Cylinder Cover	100-130	11-14.5	•	•	•	•	•	•	•	•	•	•	•
Flywheel Nut (Cast Iron)	500-600	42-50	•	•	•	•	•	•	•	•	•	•	•
Flywheel Nut (Aluminum)	400-500	45-56.5	•	•	•	•	•	•	•	•	•	•	•

FOUR-CYCLE MEDIUM FRAME ENGINE SERIES

(TVM, TVXL, H, V, HM, OVM, OVXL, OHM, OHSK and OHV)

Location	Inch lbs. Torque	Nm	Engine Designation											
			TVM125, 140	H50-60	V70	H70	TVM & TVXL 170-195-220	HM/HMSK70-100	OVM/OVXL, OHV120-125	OHSK80-130 OHM120	OHV11-13, OHV110- 135, 206 Series	OHV135-145 203 Series	OHV15-17.5 204 Series	
Connecting Rod	160-180	18-20.5	•	•										
Connecting Rod	200-220	22.5-25			•	•	•	•	•	•				
Connecting Rod	200-240	22.5-27											•	
Cylinder Head Bolts	220-240	25-27									•		•	
Cylinder Head Bolts	180-240	20.5-27								•			•	
Cylinder Head Bolts	160-210	18-24	•	•	•	•	•							
Rocker Adj. Lock Screw	65-80	7-9											•	
Rocker Arm Stud Lock Nut	110-130	12.5-14.5									•			
Rocker Arm Hex Jam Nut	15-20	2								•				
Rocker Arm Studs	170-210	19-24								•			•	
Rocker Arm Box to Head	75-130	8.5-14.5								•				
Rocker Box Cover	15-20	2								•				
Rocker Box Cover (Four Screw)	40-65	4.5-7								•			•	
Mounting Flange or Cylinder Cover	100-130	11-14.5	•	•	•	•								
Mounting Flange or Cylinder Cover	110-140	12.5-16						•	•	•	•	•	•	
Flywheel Nut	400-550	45-62	•	•	•	•								
Flywheel Nut (External Ignition)	600-800	68-90						•	•	•	•	•	•	

Torque Specifications - *continued*

FOUR-CYCLE LARGE FRAME ENGINE SERIES (CAST IRON BLOCK HH, VH and OH)

Location	Inch lbs. Torque	Nm	Engine Designation		
			HH	VH	OH
Connecting Rod	86-110	10-12.5	●	●	●
Cylinder Head	180-240	20.5-27	●	●	●
Mounting Flange & Cylinder Cover	100-130	11-14.5	●	●	●
Rocker Arm Shaft to Box	180-220	20.5-25			●
Rocker Arm Box to Cylinder Head	80-90	9-10			●
Flywheel Nut	600-660	68-74.5	●	●	●

FOUR-CYCLE HEAVY FRAME ENGINE SERIES (V-TWIN)

Location	Inch lbs. Torque	Nm	Engine Designation	
			TVT	
Connecting Rod	200-220	22.5-25	●	
Cylinder Head Bolts	220-240	25-27	●	
Rocker Arm Jam Nut	110-130	12.5-14.5	●	
Rocker Arm Cover Mounting Screw	52	6	●	
Mounting Flange/Cylinder Cover	240-260	27-29	●	
Flywheel Nut	600-800	68-90	●	

Four Cycle Troubleshooting

As an aid in troubleshooting any piece of equipment, interview the customer, and review conditions and symptoms of problem. Examine exterior for clues: leaks, excessive dirt, damaged or new parts.

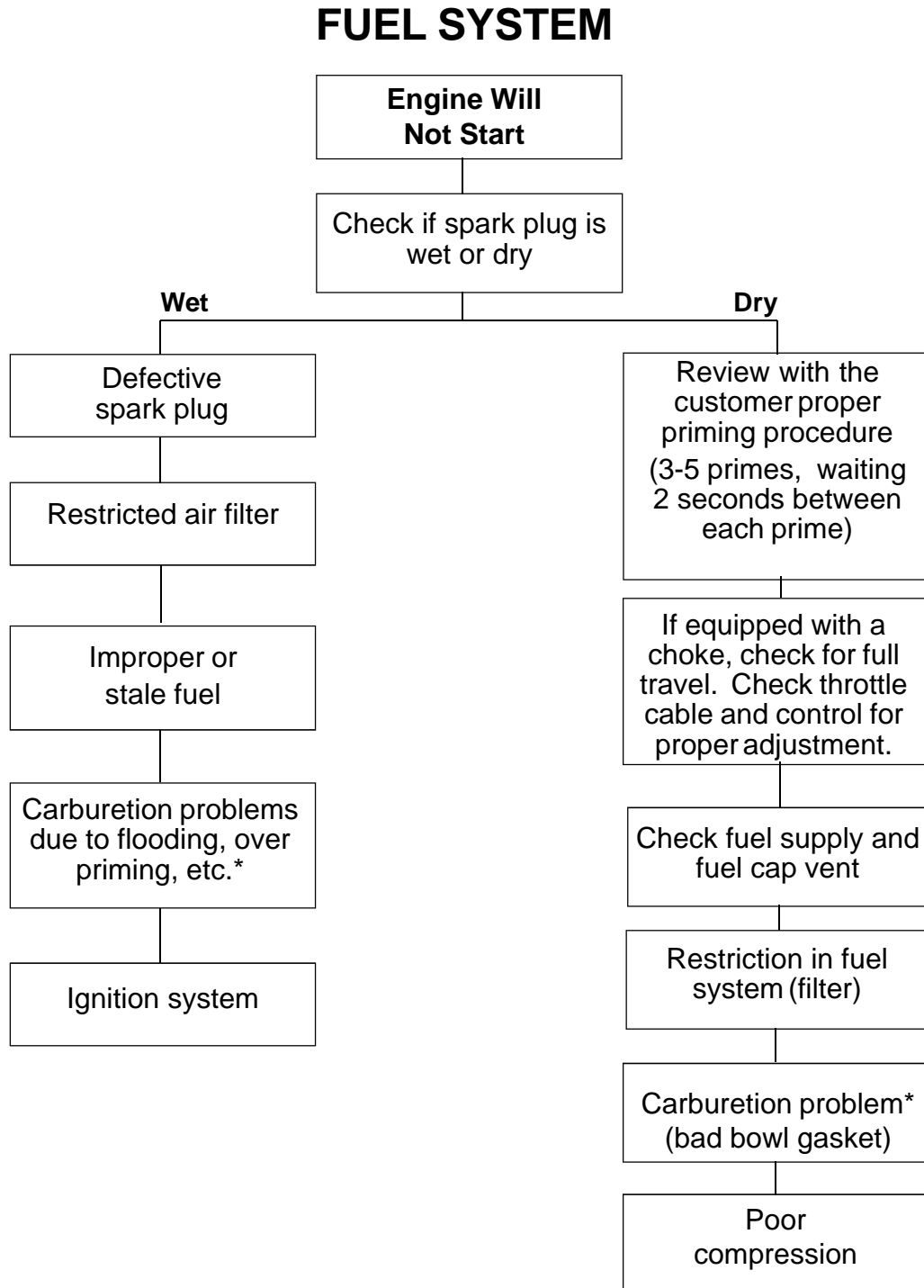

NOTE: Refer to Technician's Handbook for a more detailed list of remedies.

*Carburetor Troubleshooting, use Technician's Handbook or Carburetor Troubleshooting Booklet, Form No. 695907. Video No. 695015.

Four Cycle Troubleshooting - *continued*

IGNITION SYSTEM

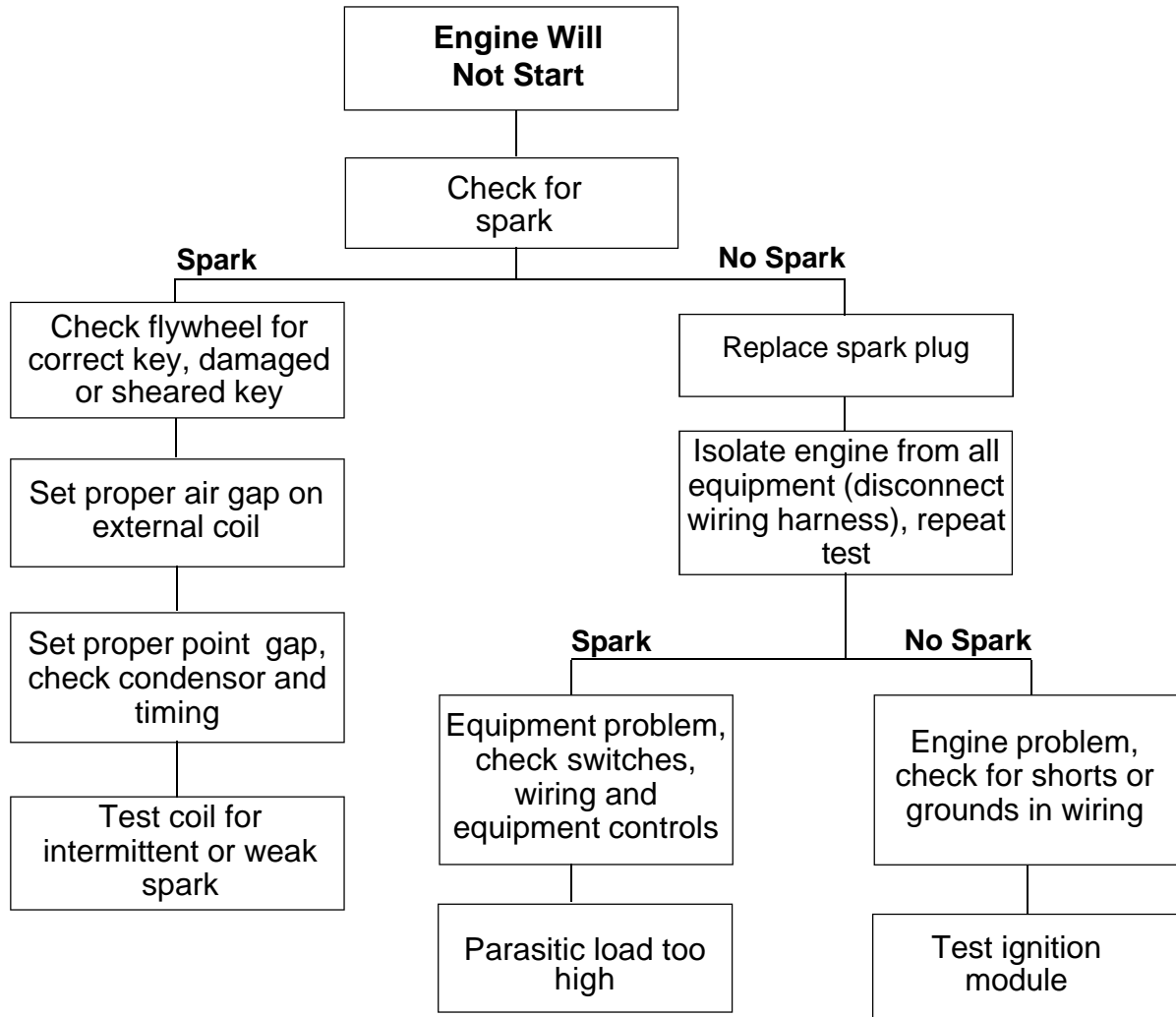

NOTE: Refer to Technician's Handbook for a more detailed list of remedies.

Tecumseh 2 Cycle Diaphragm Adjustments

NOTE: For meeting emission requirements, some carburetors have fixed-main or idle jets. The absence of the adjustment screw indicates fixed jets and no adjustment is necessary.

Diaphragm-Dual Adjustment.

Turn mixture adjusting screws in finger tight to the closed position, then one (1) turn out from closed position. This setting is approximate. This will allow the engine to be started so the carburetor can be fine tuned.

Start the engine and let it warm up for approximately 3-5 minutes. **Do not adjust the carburetor when the engine is cold.**

Set the throttle control to idle. If it is a fixed speed type, manually hold the throttle against the idle speed adjustment screw.

The throttle lever must be held against the crack screw for low speed adjustments or all adjustments will be incorrect and cause poor performance and unsatisfactory operation.

With the engine idling and throttle lever against the idle speed regulating screw, turn the low speed adjustment screw slowly clockwise from the NORMAL setting until the engine falters. Remember this location. Turn the screw counterclockwise until engine just starts to sputter or drops in R.P.M.. Remember this location. Turn the screw clockwise until it is halfway between your first position where the engine faltered and your last position where the engine started to sputter. This will be the optimum low speed setting on your carburetor.

Next run the engine at governed speed. The high speed adjustments are made basically the same as the low speed adjustments, with the exception of the settings being made 1/8 of a turn at a time, from the NORMAL settings. **NOTE:** It may be necessary to re-check the idle mixture adjustment after performing the high speed adjustment.

Diaphragm-Single Adjustment.

Turn the mixture adjustment screw finger tight to the closed position, then one (1) turn out from the closed position. This setting is approximate and will allow the engine to be started so the carburetor can be fine-tuned.

Start the engine and let it warm up for approximately 3-5 minutes. Do not adjust the carburetor when the engine is cold.

Set the throttle control to idle. If it is a fixed speed type, manually hold the throttle against the idle speed adjustment screw.

NOTE: If the engine falters or stops after the choke lever is moved to the "OFF" position, open the mixture adjusting screw 1/4 turn (counterclockwise) and restart the engine.

With the engine running, place the speed control in the "slow" position to make mixture adjustments. Turn the mixture screw slowly clockwise from the NORMAL setting until the engine falters. Remember this location. Turn the screw counterclockwise until the engine just starts to sputter or drops in R.P.M. Remember this location. Turn the screw clockwise until it is halfway between your first position where the engine faltered and your last position where the engine started to sputter. This will be the optimum setting on your carburetor.

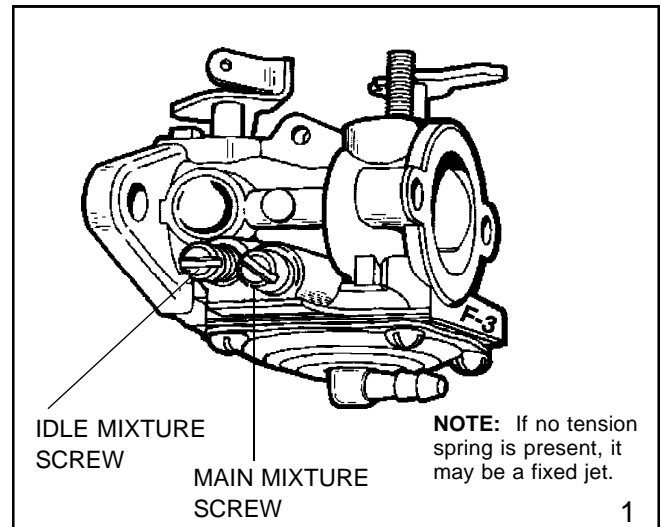

TC Series Governor Adjustment

Three different styles of governor systems are used on TC engines. Use the following illustrations (diags. 2 and 3) to identify the governor system used and the following procedure to adjust the governed engine speed.

1. Allow the engine to run for at least 5 minutes to reach operating temperature. Make sure the air filter (if equipped) is clean and the choke is in the off position.
2. Using a Vibratach (part# 670156) or other tachometer, determine the engine's R.P.M. at idle and wide open throttle. Refer to Microfiche card 30, or a computer parts look-up program to obtain the recommended engine speeds.
3. Using the applicable illustration, either bend the speed adjusting lever toward the spark plug end of the engine to decrease high speed R.P.M., or bend the lever in the opposite direction to increase R.P.M. On TC Type II engines, turn the speed adjustment screw out to increase or in to decrease engine high speed R.P.M. If the speed adjustment screw is turned out to increase the engine R.P.M., the speed control lever must be moved to allow the speed control plunger to contact the speed adjustment screw.
4. The low speed is set by moving the throttle control to the lowest speed position and adjusting the low speed adjustment screw on the carburetor.

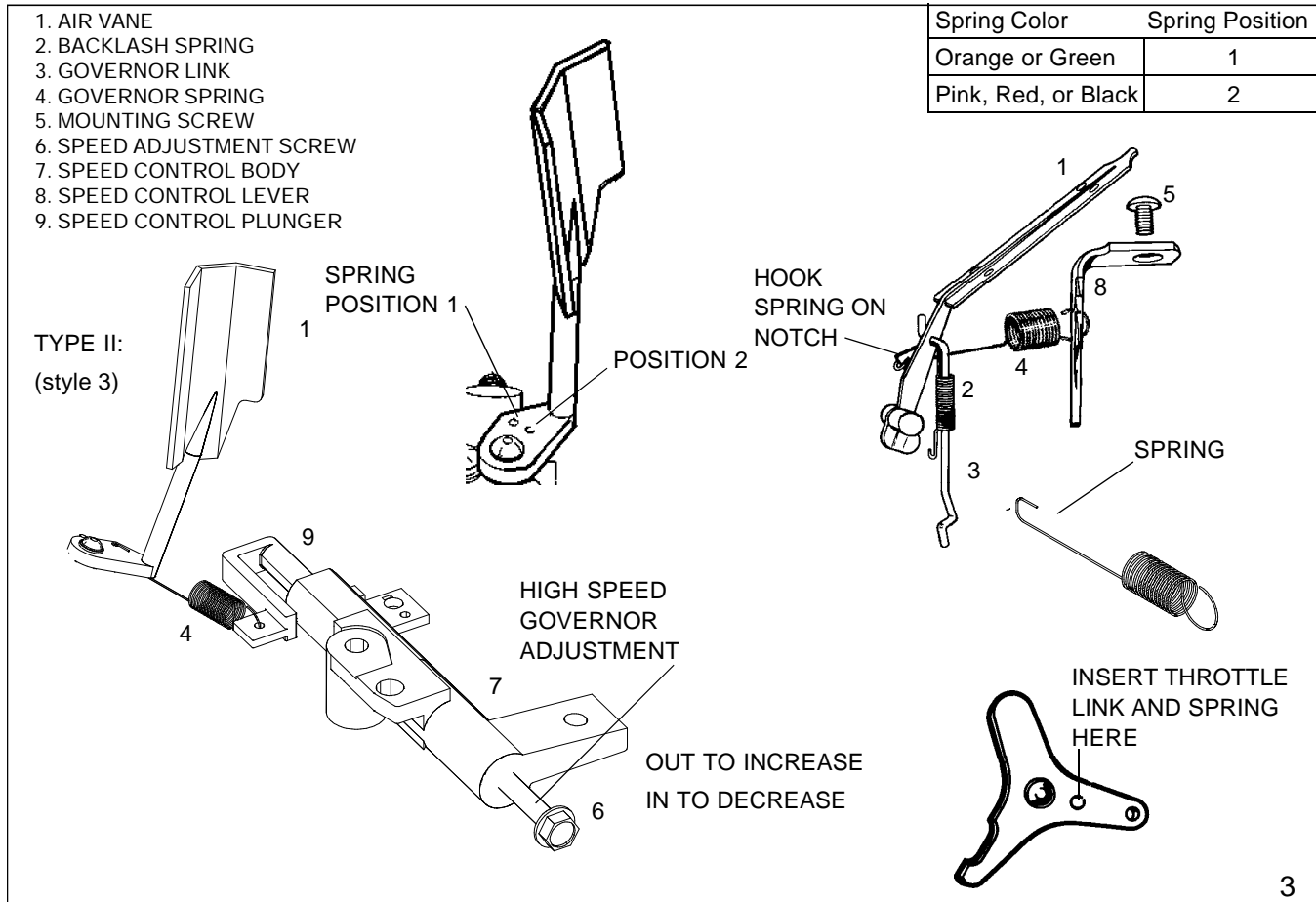
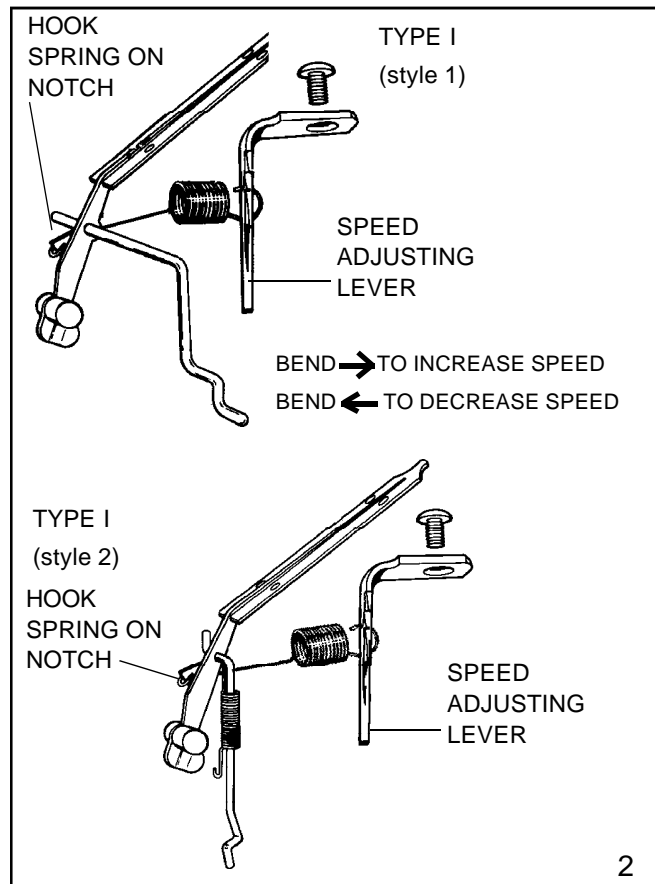

Walbro (WTA, WT) and Tillotson (HU) Diaphragm Adjustment

Carburetor Pre-Set and Adjustment

Both the Walbro and the Tillotson carburetors used on TC engines have non-adjustable main mixture jets. Only the idle mixture is adjustable by turning the idle mixture screw. Use the following procedure to pre-set the idle mixture screw. Turn the idle mixture screw (clockwise) finger tight to the closed position, then turn the screw counterclockwise to obtain the proper preset (diag. 4).

Walbro Model WTA, WT 1 - 1-1/8 turns

Tillotson Model HU 1-1/4 - 1-3/8 turns

Final Idle Mixture Adjustment

Start the engine and allow it to reach normal operating temperature (after 3-5 minutes). As the speed control is set at the idle position, turn the idle mixture screw slowly clockwise until the engine R.P.M. just starts to decrease. Stop and note this screw position. Turn the idle mixture screw slowly counterclockwise, the engine will increase in R.P.M. Continue to slowly turn the screw until the engine R.P.M. starts to decrease. Note this position and turn the mixture screw back clockwise halfway between the two engine R.P.M. drop off positions. The idle mixture adjustment is complete.

Some carburetors came equipped with a main mixture adjusting screw. To adjust the main mixture, follow the steps for idle adjustment.

Emissionized Tillotson

Similar in design and operation, the Tillotson emission carburetor uses a fixed main jet with an adjustable idle. The idle circuit has a limiter cap to prevent over richening. The cap is locked onto the adjustment screw in a rich position, allowing only a leaner adjustment. The main is fixed on these, which means that the main mixture limiter is non-functional on Tecumseh built engines (diag. 4a).

In compliance with E.P.A. and C.A.R.B. regulations the following procedure must be followed.

NOTE: These caps can be removed for servicing of the carburetor. Follow these steps.

1. Turn the caps clockwise until they hit the stops.
2. Remove the caps with a pointed instrument such as an awl.
3. Then turn the screws in until softly seated, note the number of turns. The screws must be reinstalled to this same static setting. Replacement of the caps is required to maintain E.P.A. and C.A.R.B. emission compliance.

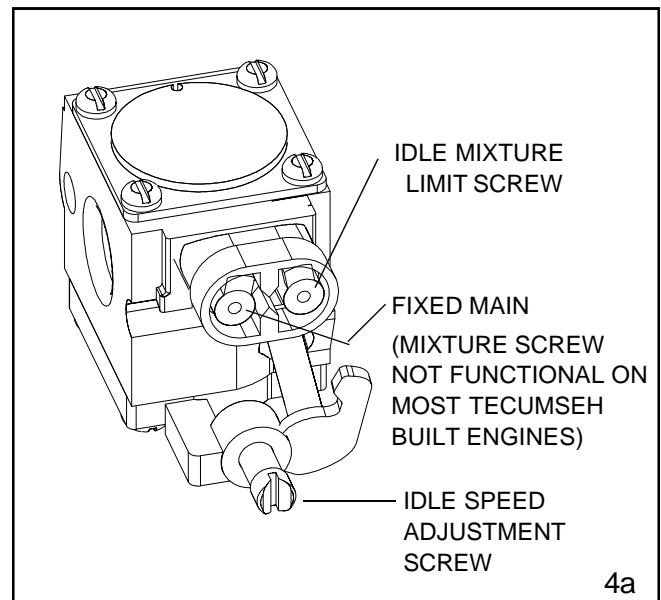
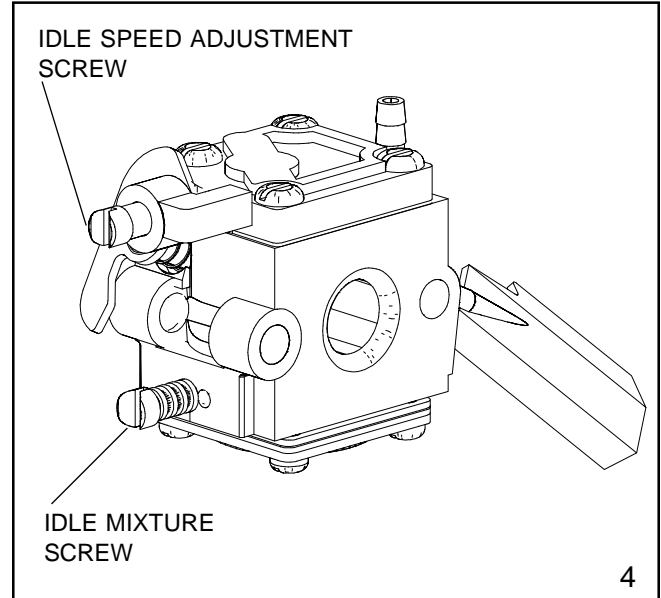

2-Cycle Engine Speed and Mixture Adjustments: TVS/TVXL840

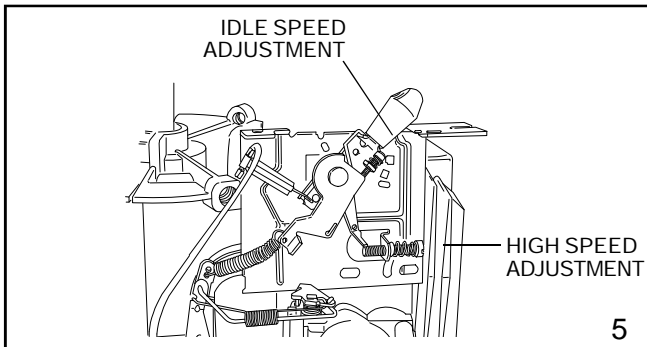

Linkage Location

To aid in the proper reassembly of the governor linkage, mark the linkage locations.

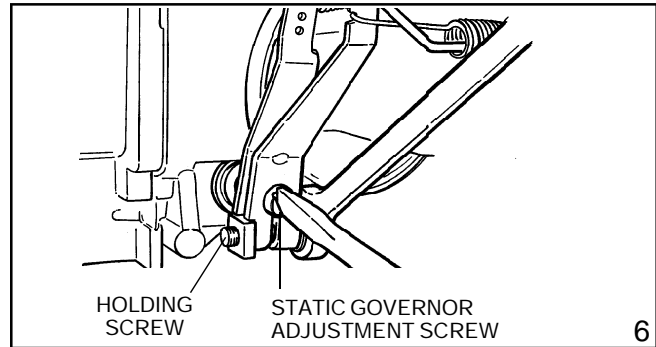

Static Governor Adjustment

To adjust the static governor, loosen the holding screw, rotate the governor arm and slotted shaft in the direction that will open the throttle to the wide open position, and then re-tighten the holding screw.

HSK/HXL840-850

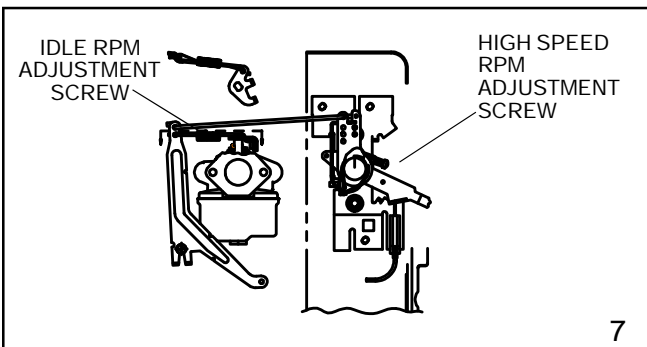

The HXL840 - 850 Series with variable speed control have the following adjustments. Idle speed is set at the carburetor crack screw. High speed is set with the screw shown above. Always check Microfiche card 30 or Parts Smart computer program for correct speed settings.

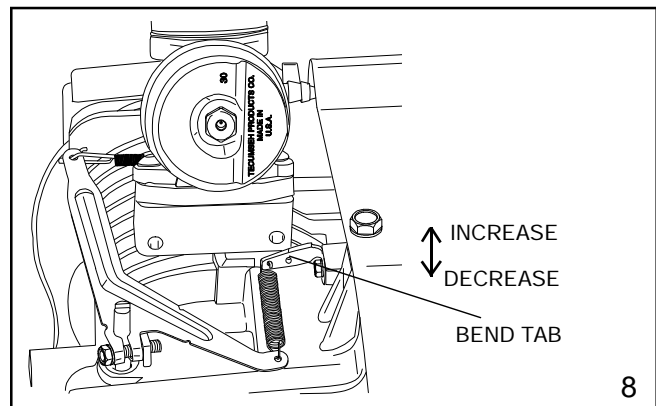

R.P.M. adjustment of fixed speed models is done by bending the tab as shown.

Governor and Linkage for Air Vane

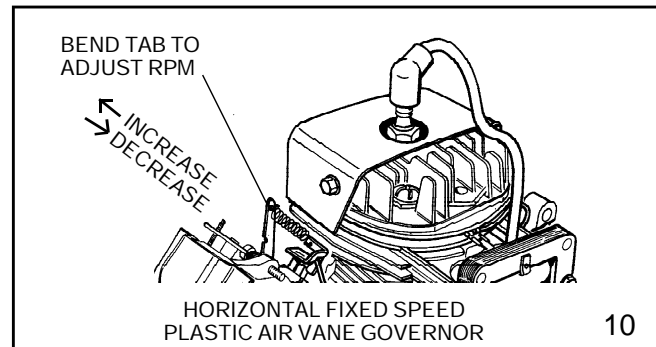
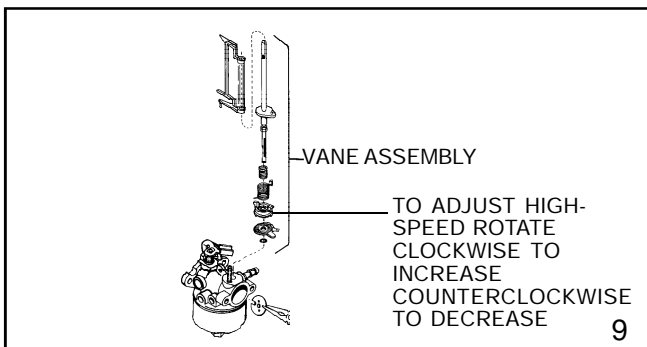

Rotate sleeve clockwise to increase R.P.M., counterclockwise to decrease R.P.M.

NOTE: The sleeve is serrated to rotate in a clockwise direction and must be raised using the sleeve tabs before it can be rotated counterclockwise.

To disassemble, remove choke shutter with needle-nose pliers; the vane assembly may then be removed from the carburetor.

Governors and Linkage for Air Vane - *continued*

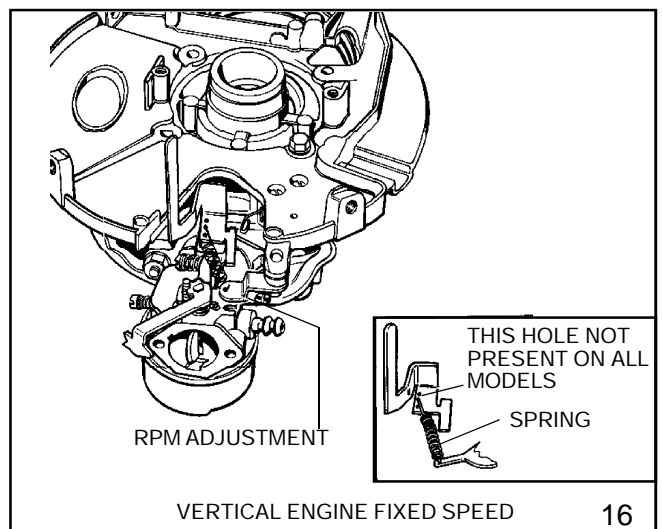
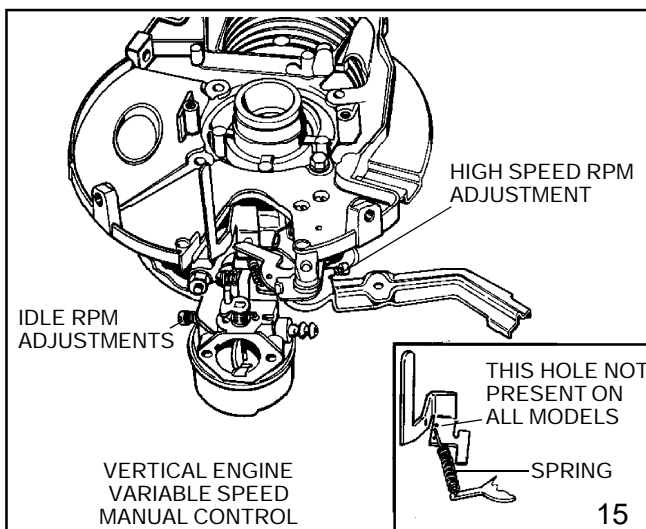
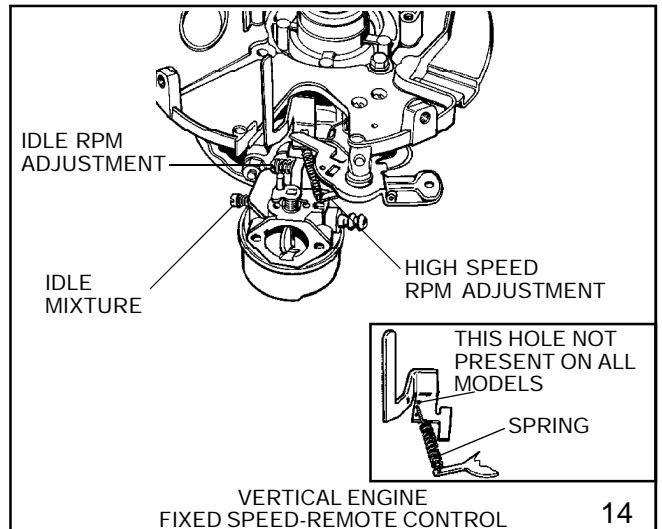
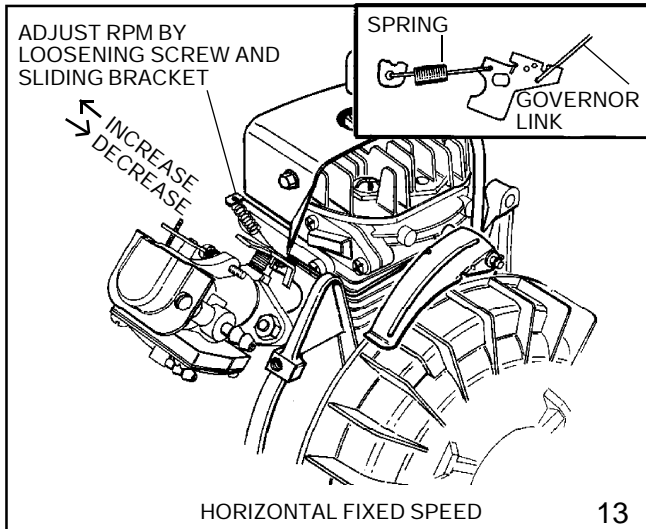
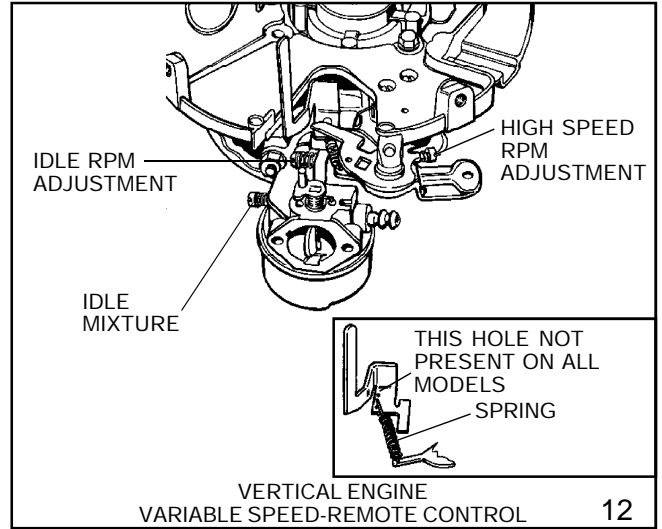
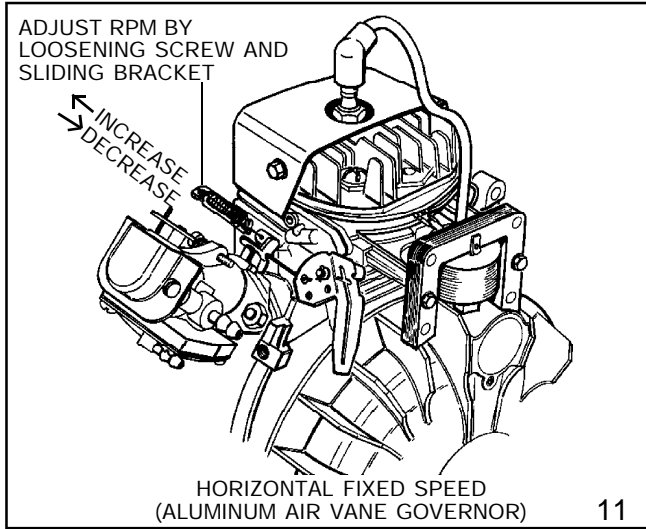

Static Governor Adjustments

The purpose of making a static governor adjustment is to remove all free-play between the governor spool and the carburetor (see illustration). Any free-play here will result in hunting/surging or erratic running. After completing this procedure, always re-check the engine speeds using the steps outlined in the following pages.

To set the static governor, do the following:

1. Be sure the engine is stopped or damage may occur.
2. If equipped with a throttle control, place the throttle in the high speed position.
3. Loosen the governor clamp or screw.
4. Hold the governor arm and link in the W.O.T. (wide open throttle) position, then rotate the shaft or shaft/clip assembly in the same direction and tighten the screw.
5. If engine speed adjustments are needed, follow the steps described in following pages.

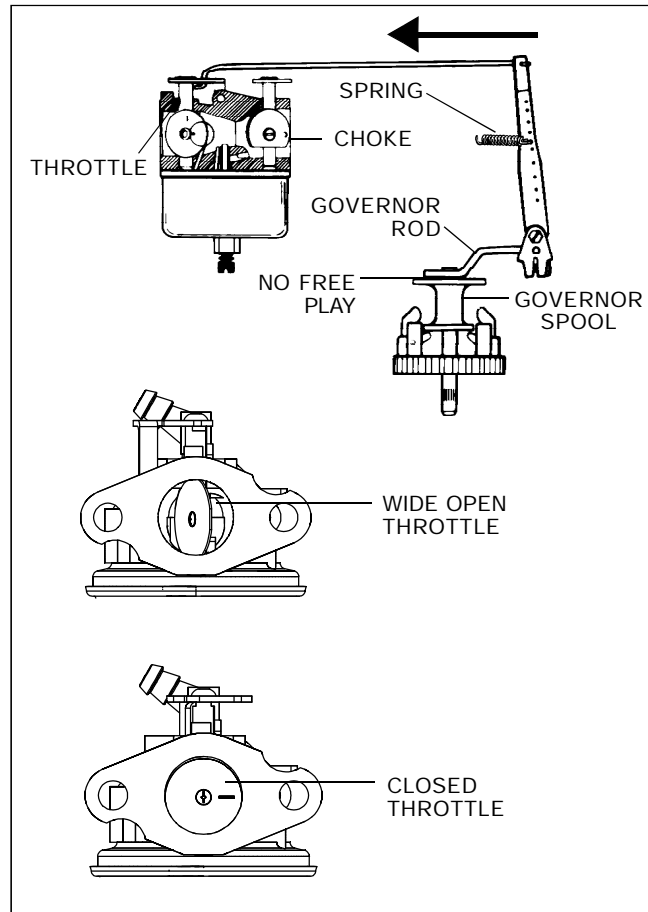

Governor Shaft Pressed In Depth

When assembling governor shaft into a flange or cover mounting boss, refer to this chart for exposed shaft length.

Engine Model	Exposed Shaft Length	Engine Model	Exposed Shaft Length
ECH 90 ECV 100 H 30, 35 HS 40, 50 LAV (all) LEV (all) OHH (all) OVRM (all) TNT 100, 120 TVS (all) VLV (all)	Mounting flange to top 1.319 - 1.334" (33.502 - 33.883 mm)	H 50, 60, 70 HH 60, 70 HHM 80 HM 70, 80, 100	Mounting flange to shoulder 1.283 - 1.293" (32.588 - 32.842 mm)
		OHV 11-17 OVM 120 OVXL 120, 125	Mounting flange to top 1.350 - 1.365" (34.290 - 34.671 mm)
		OHM 90-120 OHSK 90-130	Mounting flange to top 1.085 - 1.100" (27.559 - 27.940mm)
TVM (all) V 50, 60, 70 VH 50, 60, 70	Mounting flange to top 1.581 - 1.596" (25.806 - 26.314mm)	OH 120-180	Mounting flange to top 1.00" (25.400mm)
HH 100, 120 VH 100	Mounting flange to top 1.016 - 1.036" (25.806 - 26.314 mm)	TVT - V -Twin	Mounting flange to top 1.196 (3.969 mm)

Small Frame, Vertical and Horizontal*

Models: LAV35,40,50 - H25,30,35 - HS40,50 - HSK - HSSK - TNT100,120 - ECH90 - TVS75,90,105,115,120 - OVRM ALL - ECV100,105,110,120

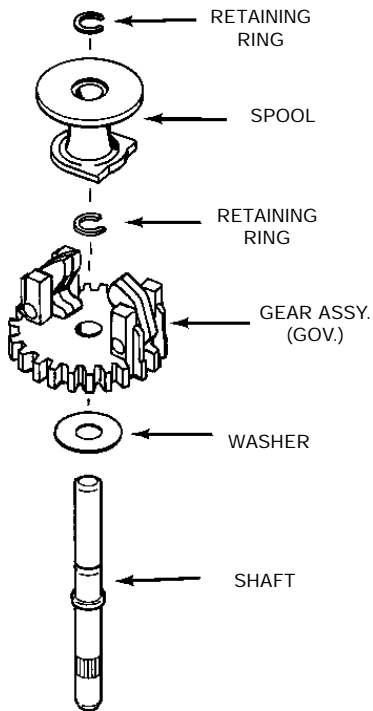

* As of August 1992, all small frame engines, including VLV40-6.75, use a retainerless shaft. Service replacement shafts will be retainerless for all small frame and VLV engines.

Retainerless Governor System for Small Frames*

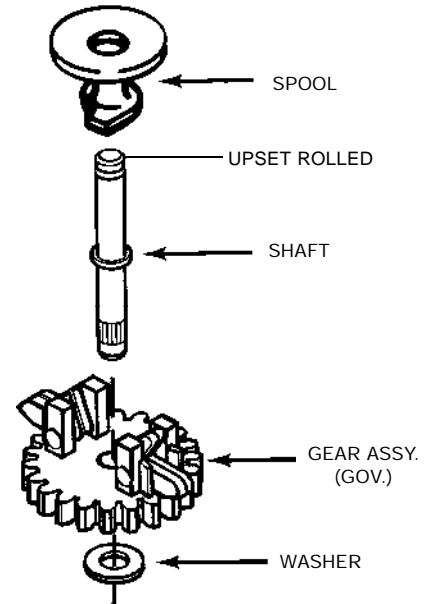

NOTE: Gear assembly must have .010 - .020 (.25 - .50 mm) end play after shaft is installed into flange.

* As of August 1992, all small frame engines, including VLV40-6.75, use a retainerless shaft. Service replacement shafts will be retainerless for all small frame and VLV engines.

VLV*40, 50, 55, 60, 65, 66

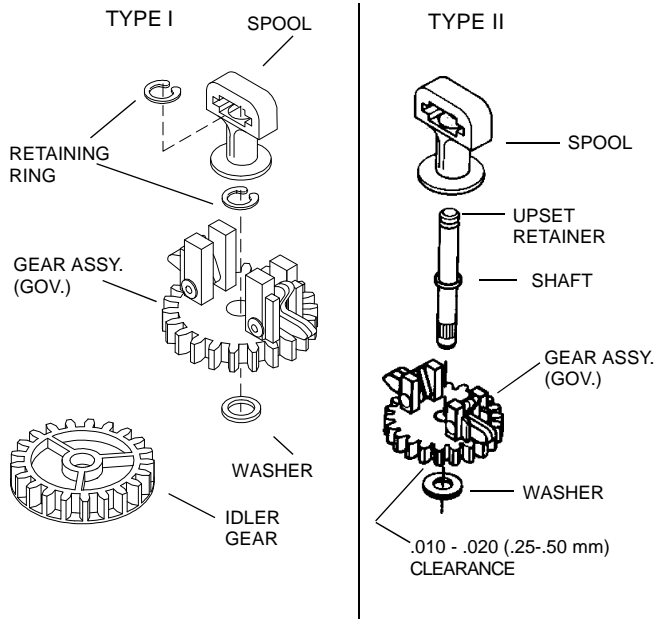

NOTE: Gear assembly must have .010 - .020 (.25 - .50 mm) end play after shaft is installed into flange.

* As of August 1992, all small frame engines, including VLV40-6.75, use a retainerless shaft. Service replacement shafts will be retainerless for all small frame and VLV engines.

Medium Frame Vertical

Models: TVM125, 140, 170, 195, 220 - V50,60,70 - VH50,60,70

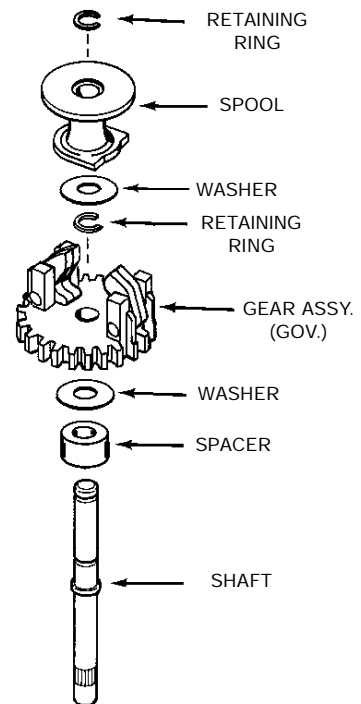

Medium Frame Horizontal

Models: HH60,70 - H50,60,70 - HM70,80,100 - HMSK

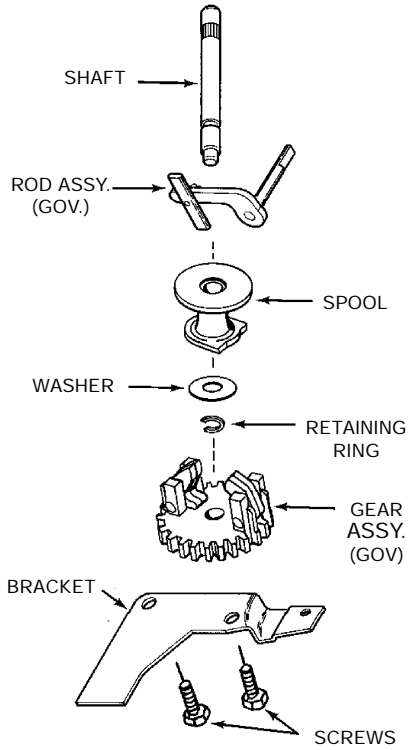

OHM120 - OHSK 80-130

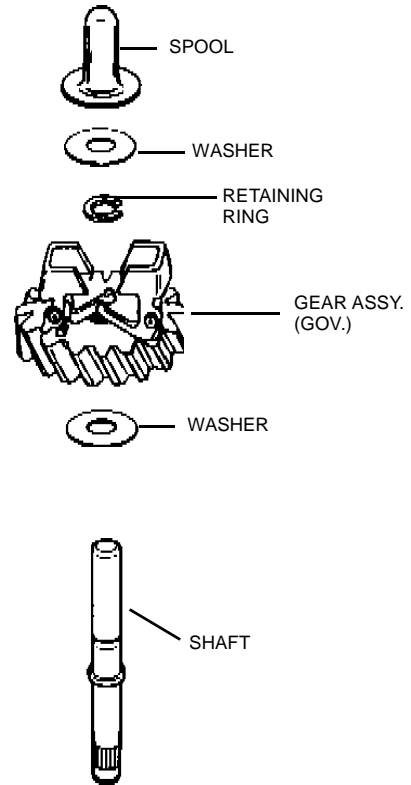

OVM120, OVXL120, 125 - OHV11-17

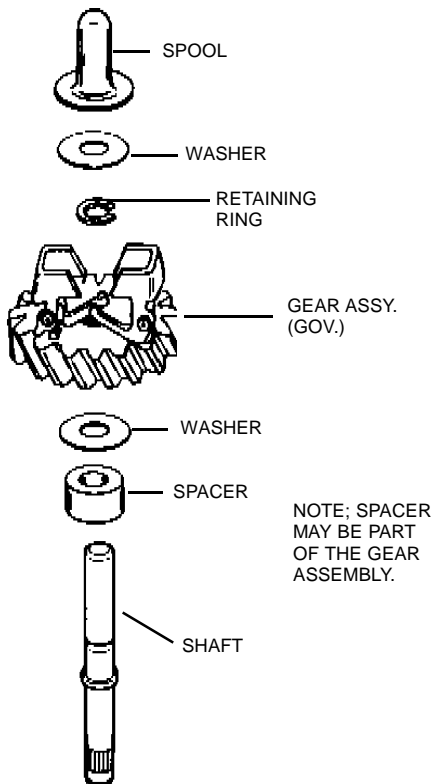

NOTE: On models OHV13.5-17, the spacer is cast as part of the governor gear with the washer placed below the gear assembly.

OH120, 140, 160, 180

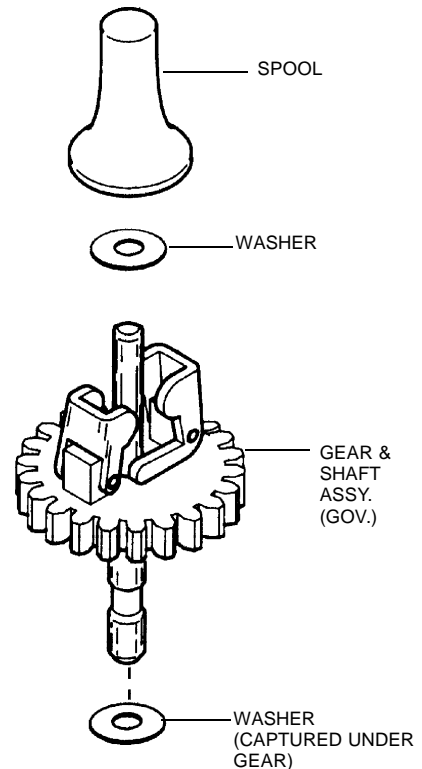

Engine Speed and Mixture Adjustments

3-5 H.P. Vertical Shaft Engines

NOTE: Starting and operating problems may exist when engines are used at high elevations (over 4,000 feet above sea level). In cases where a fixed main carburetor is used, refer to Bulletin 110 for correction. **Engines which are identified as compliant with CARB (California Air Resources Board) or EPA (US Environmental Protection Agency) regulations can NOT be changed from their factory jetting unless specifically authorized.**

Before making any speed or carburetor adjustments be sure to adjust the governor and control bracket. See Governor Section of the Booklet.

To adjust the speed control bracket, determine whether the carburetor is an adjustable type, then proceed.

Some carburetors may have a choke lever which is operated by the speed control bracket. To adjust the speed control bracket for full choke operation, loosen the speed control bracket mounting bolts and move the speed control lever to the high speed/full choke position. Next insert a small piece of wire through the hole in the speed control bracket, choke actuating lever, and the choke lever (diag. 18). When all three holes are aligned tighten the mounting bolts.

Once the speed control bracket is adjusted, the main and idle fuel mixtures can be adjusted. Start the engine and allow it to warm up to normal operating temperature (3 - 5 minutes). Set the speed control to the HIGH or FAST position, then turn the main mixture adjustment screw in (clockwise) slowly until the engine begins to run erratic (lean). Note the position of the screw. Now, turn the screw out (counterclockwise) until the engine begins to run erratic (rich). Turn the screw in (clockwise) midway between these two positions. This will be the best setting.

Set the speed control to the IDLE or SLOW position. Adjust the idle mixture screw following the same procedure used to adjust the main mixture adjustment.

NOTE: SOME CARBURETORS HAVE FIXED MAIN JETS. THE ABSENCE OF THE ADJUSTING SCREW INDICATES A FIXED JET AND NO ADJUSTMENT IS NECESSARY.

After adjusting the fuel mixtures, engine speeds can be adjusted. The correct operating speeds are found on Microfiche card 30 of the Tecumseh Master Parts Manual, or the computer parts look-up program (Part Smart). On engines with adjustable carburetors (diag. 19 and 20) the high speed adjustment will be in one of two places. The first location is on the speed control lever (diag. 19).

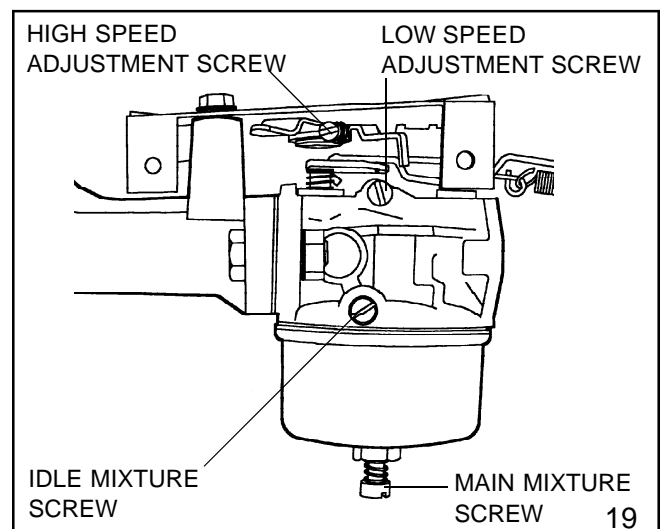
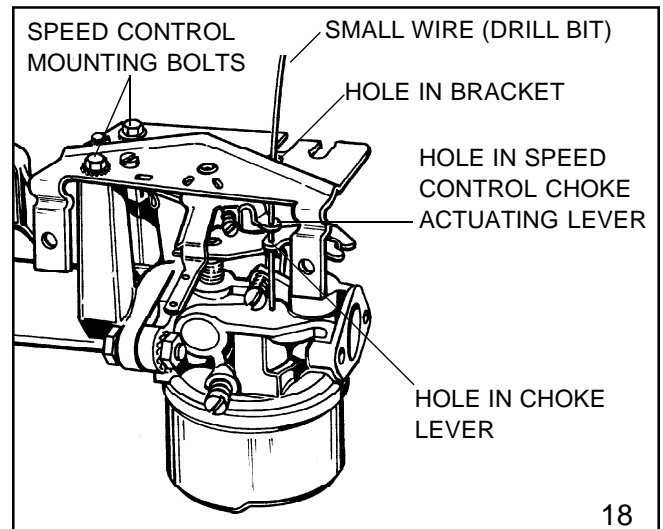
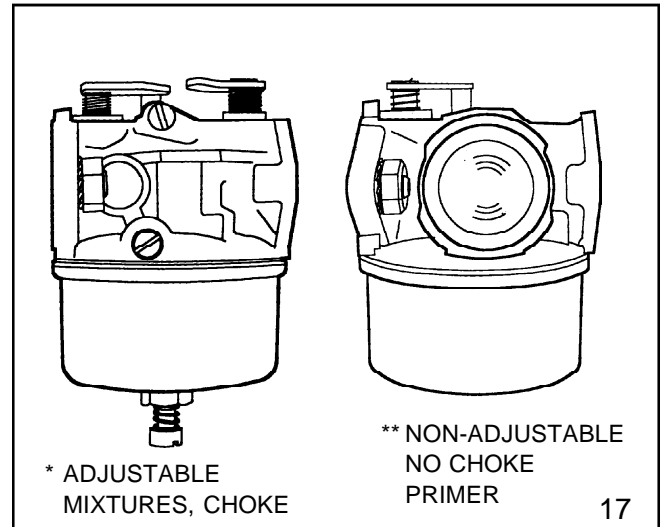

Engine Speed and Mixture Adjustments - *continued*

3-5 H.P. Vertical Shaft Engines

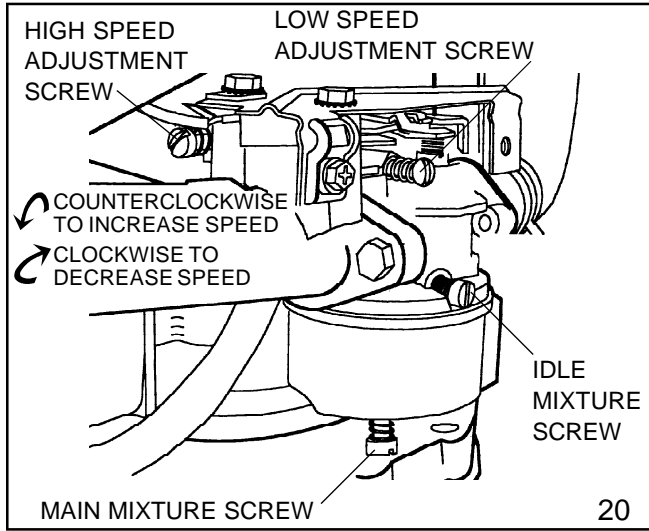

The second is on a bracket located between the blower housing and the speed control (diag. 20). Low speed is adjusted by the throttle crack screw on the carburetor (diag. 19 and 20).

It may be necessary to preset the carburetor mixture screws.

Tecumseh Carburetors

Engine Model	Main Pre-set	Idle Pre-set
All models with float-type carburetors	1-1/2 turn	1 turn
All models with diaphragm-type carburetors	1 turn	1 turn

Some speed control brackets are adjusted by loosening the speed control bracket mounting bolts and sliding the bracket all the way to the right and re-tightening the mounting bolts (diag. 21). The high speed adjustment screw is located on the speed control lever (diag.22) Some carburetors are fixed speed and are adjusted by bending the adjusting tab attached to the intake manifold (diag. 23).

After setting the engine speeds recheck the fuel mixtures, then recheck the engine speeds.

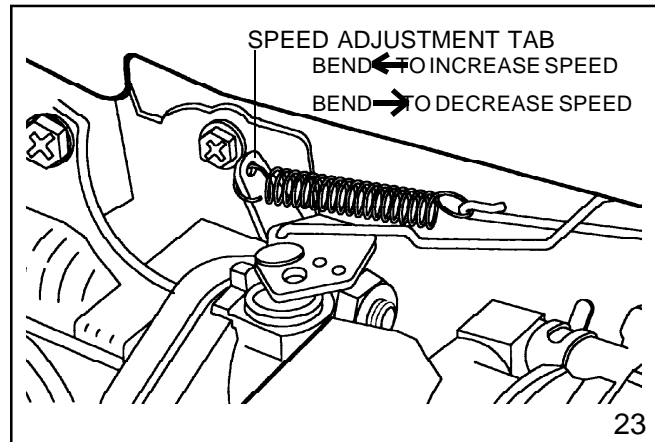
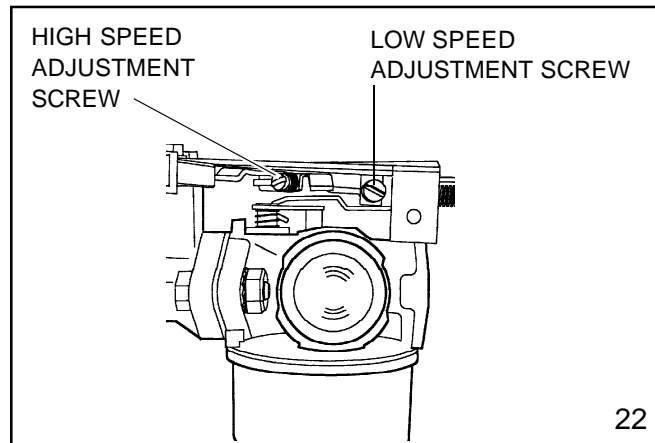
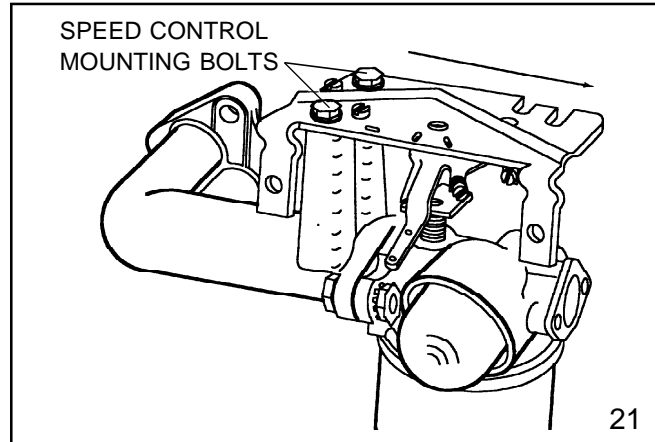

Engine Speed and Mixture Adjustments - *continued*

3-5 H.P. Vertical Shaft Engines

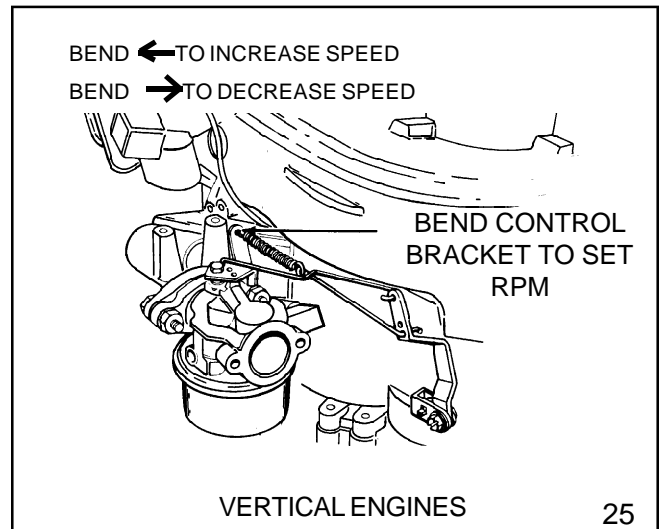
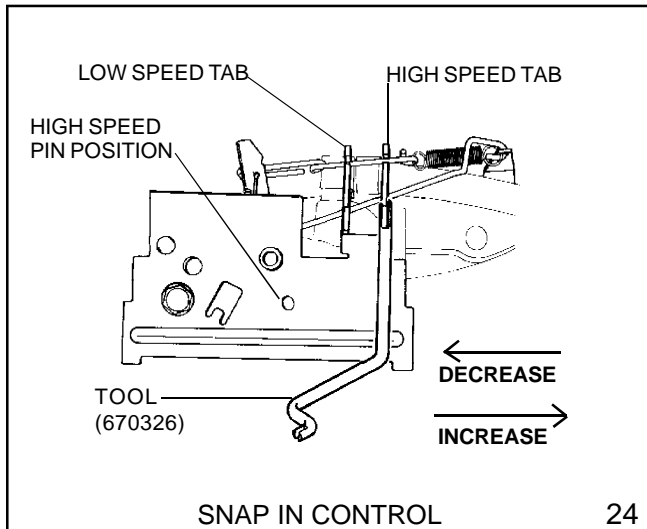

GOVERNED / NON-GOVERNED IDLE

With the engine running at its lowest speed, set the governed idle at the designated R.P.M. by bending the idle R.P.M. tab. Next set the non-governed idle by pushing the bottom of the governor lever away from the control brackets, so the throttle lever contacts the idle speed screw. Hold the lever in this position and turn the idle adjustment screw clockwise to increase or counterclockwise to decrease engine idle speed. The setting on the carburetor screw should be set at 600 R.P.M. below the governed idle setting. This setting prevents the throttle plate from closing when going from high speed R.P.M. to low speed R.P.M. If improperly adjusted, the engine could experience an over lean condition.

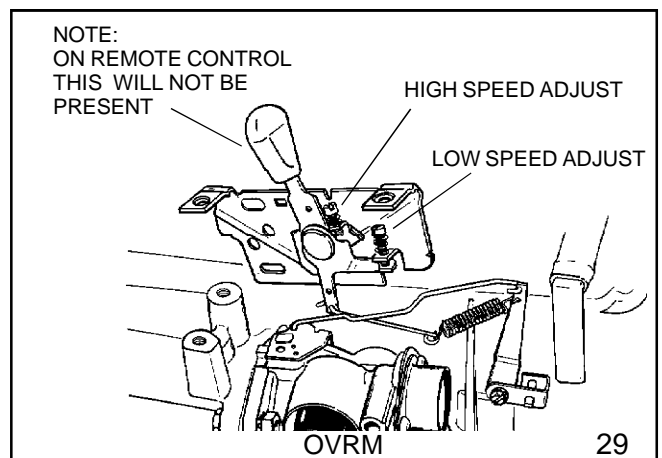
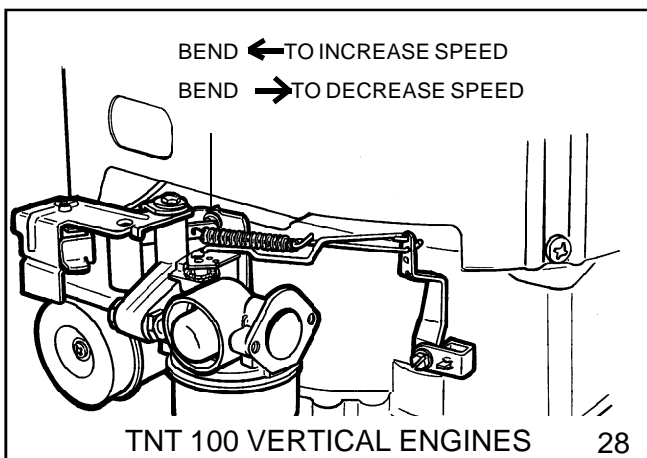
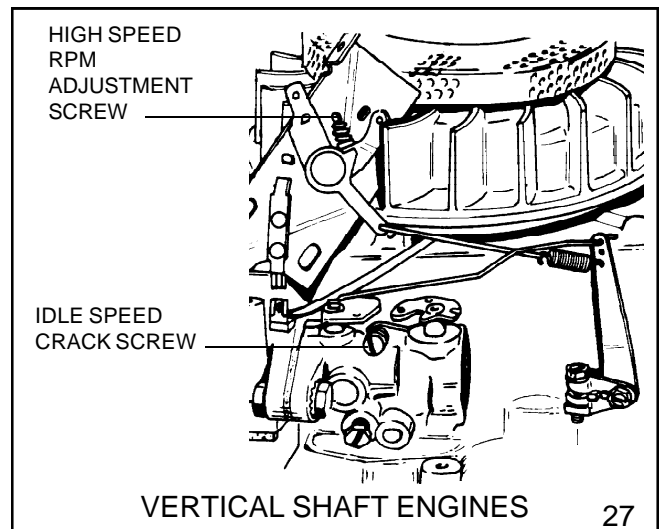
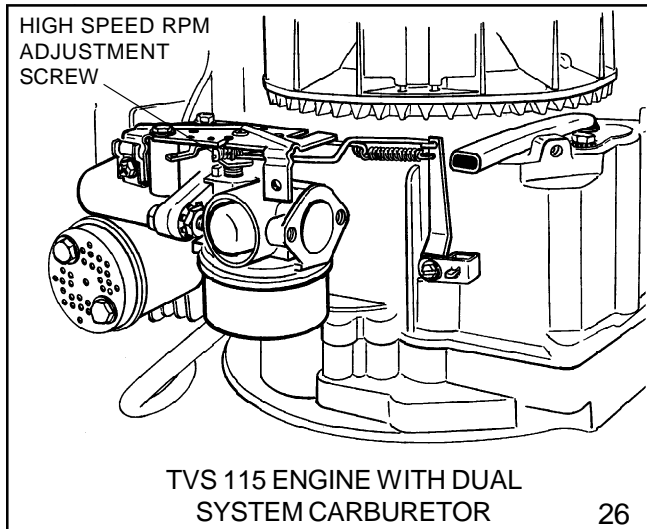

VLV Governor and Linkage

Governor Adjustment

With the engine stopped, loosen the screw holding the governor clamp and lever. Turn the clamp clockwise, then push the governor lever (connected to the throttle) to a full wide open throttle position. Hold the lever and clamp in this position and tighten the screw.

Linkage Installation

The solid link is always connected from the throttle lever on the carburetor to the lower hole on the governor lever. The shorter bend has to be toward the governor. The governor extension spring is connected with the spring end hooked into the upper hole of the governor lever and the extension end hooked through the speed control lever. To remove the governor spring, carefully twist the extension end counterclockwise to unhook the extension spring at the speed control lever. Do not bend or distort the governor extension spring (diag. 30).

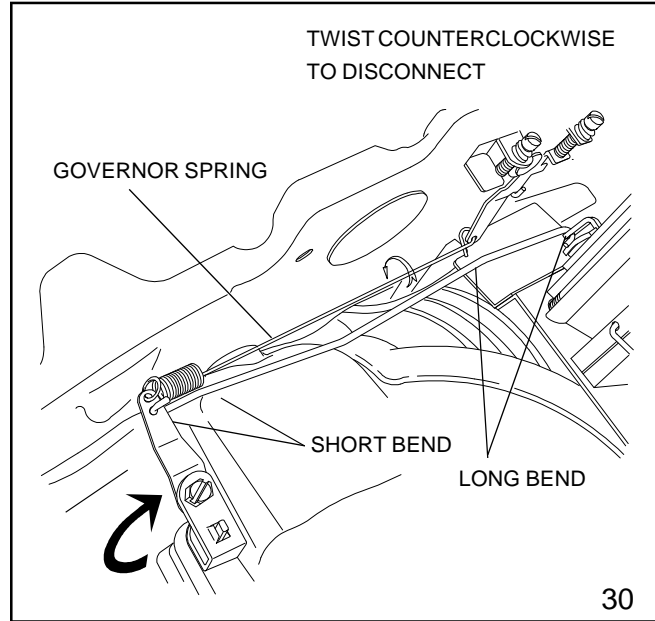

Speed Controls

This engine has an adjustable speed control. Never exceed the manufacturer's recommended speeds.

NOTE: Governor adjustment screw will be a Torx head (T-10) effective August 1, 1996 for E.C. Compliance.

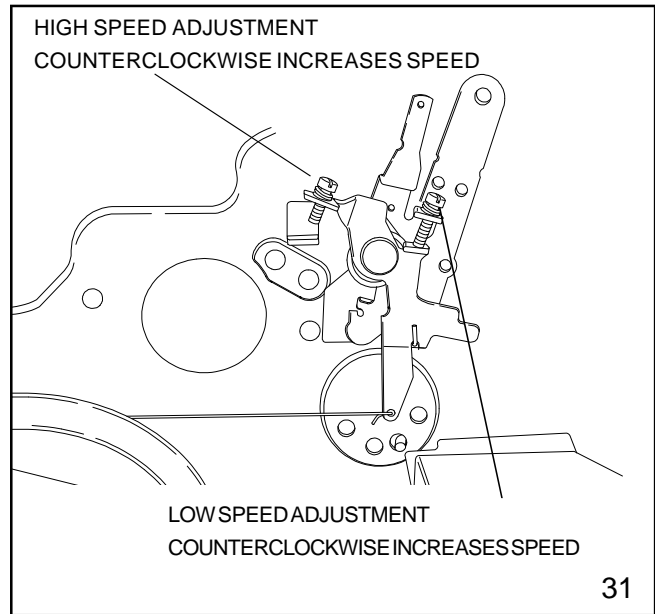

Fixed Speed

High speed governor adjustment is accomplished by bending a tab to increase and decrease engine R.P.M. Effective August 1997 (diag. 31a).

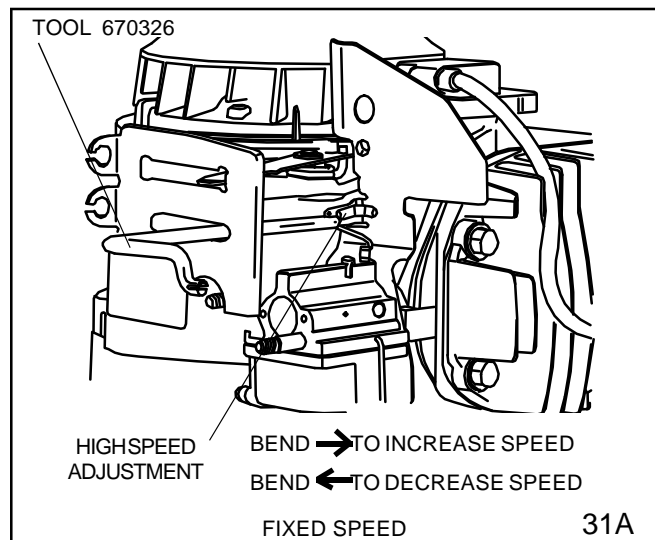

Engine Speed and Mixture Adjustments

5-15 HP Vertical Shaft Engines

The first step is adjusting the speed control bracket for full choke operation. Loosen the two speed control bracket mounting bolts and move the control lever to the full high speed/full choke position. Insert a piece of wire through the hole in the speed control bracket, the choke actuating lever, and the choke lever (diag. 32). When all three holes are in alignment retighten the speed control bracket mounting bolts.

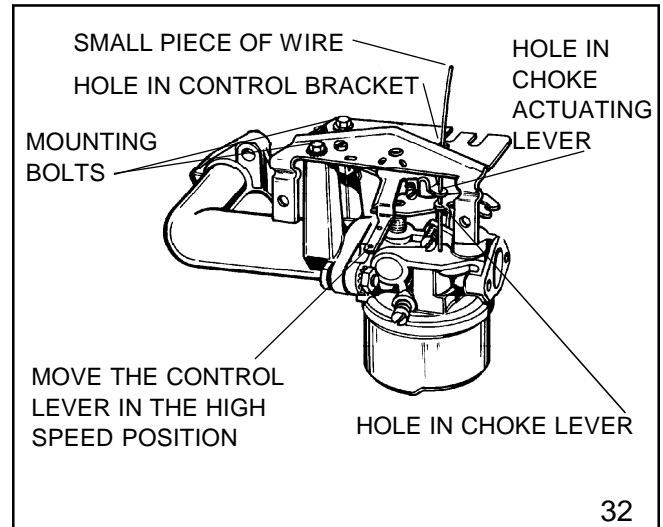

The second step is adjusting the main and idle fuel mixtures. Start the engine and allow it to warm up to normal operating temperature (3 - 5 minutes). Set the speed controls to the HIGH or FAST position, then turn the main mixture adjustment screw in (clockwise) slowly until the engine begins to run erratic (lean). Note the position of the screw. Now, turn the screw out (counterclockwise) until the engine begins to run erratic (rich). Turn the screw in (clockwise) midway between these two positions. This will be the best setting.

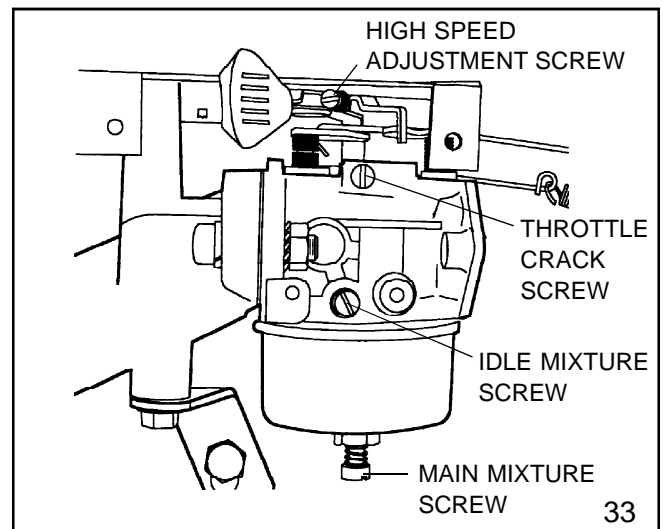

Set the speed control to the IDLE or SLOW position. Adjust the idle mixture screw following the same procedure used to adjust the main mixture adjustment screw.

NOTE: SOME CARBURETORS HAVE FIXED MAIN JETS. THE ABSENCE OF THE ADJUSTING SCREW INDICATES A FIXED JET AND NO ADJUSTMENT IS NECESSARY.

The third step is setting engine speeds. The correct engine operating speeds are listed on card 30 of the Tecumseh Master parts manual microfiche, or the computer parts look-up program (Part Smart or Plus One). The most common speed control bracket (diag. 33) has the high speed adjustment screw located on the speed control lever. The low speed adjustment screw is the throttle crack screw on the carburetor body. Another common speed control is the governor override system (diag. 34). This system has a similar speed control bracket along with a governor adjustment lever which is attached to the engine block. Both the high speed and low speed adjustment screws are located on the governor adjusting lever.

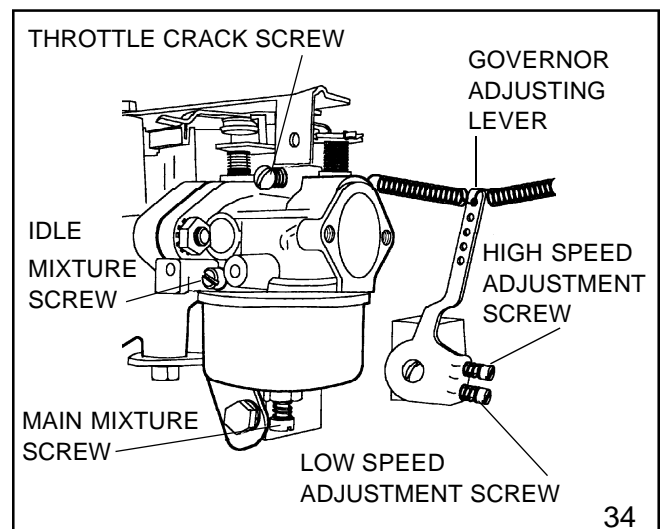

Engine Speed and Mixture Adjustments - *continued*

2.5-17.5 HP Vertical Shaft Engines

To adjust high speed on an up/down control (diag. 35) bend the adjustment tab. Low speed is adjusted by a screw at the bottom of the control bracket. Both the governor override system and the up/down speed control have a governed idle. On these systems it is important to also adjust the throttle crack screw. To adjust the throttle crack screw use your finger to hold the throttle shutter tight against the throttle crack screw and adjust the engine speed to approximately 600 R.P.M. less than the recommended low speed.

After setting the engine speeds recheck the fuel mixtures and double check the engine speeds.

NOTE: Not all engines have fully adjustable carburetors.

It may be necessary to preset the carburetor mixture screws.

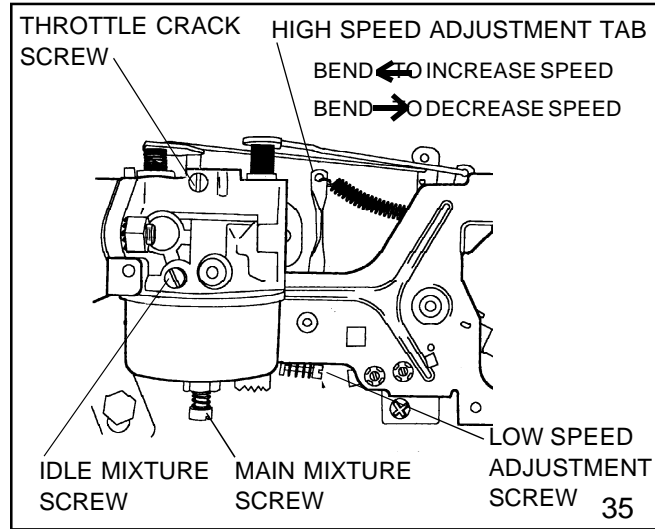

Tecumseh Carburetors		
Engine Model	Main Pre-set	Idle Pre-set
All models with float-type carburetors	1-1/2 turn	1 turn
All models with diaphragm-type carburetors	1 turn	1 turn

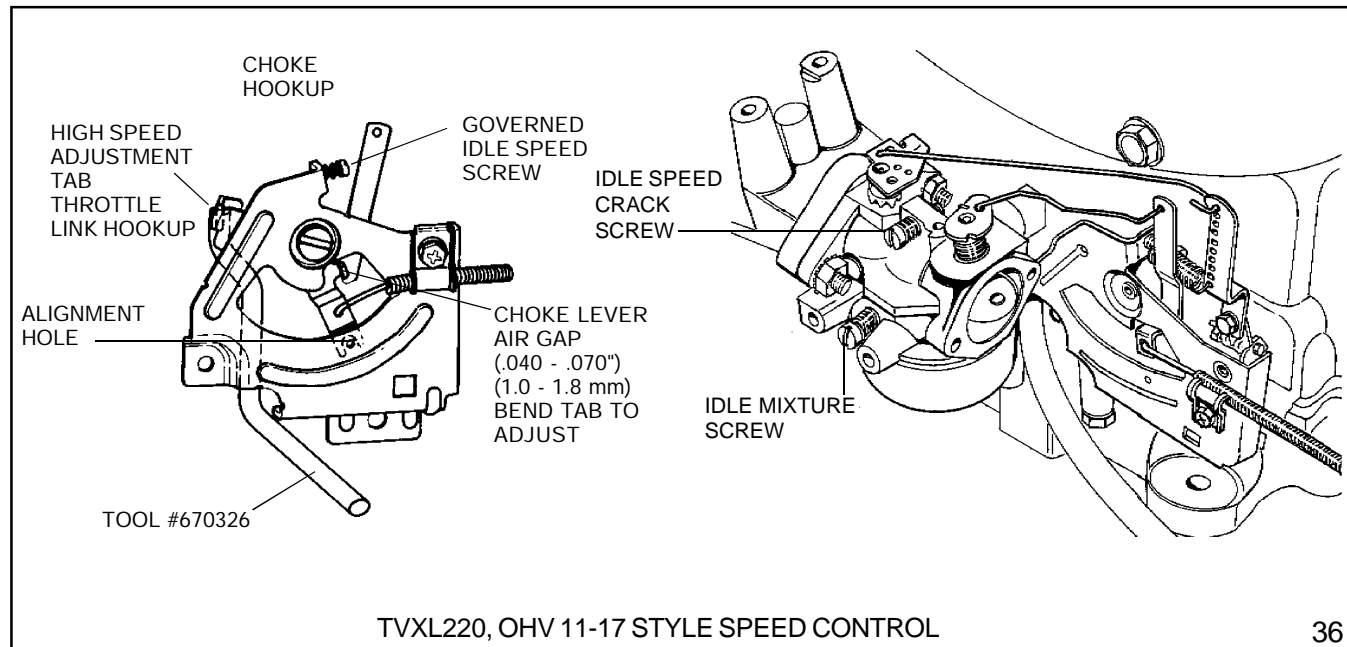

The idle speed is adjusted by turning the idle speed screw clockwise to increase engine R.P.M. and counterclockwise to decrease R.P.M. Use tool part # 670326 to adjust the high speed engine R.P.M. Place the slotted end of the tool onto the adjustment tab and bend the tab to the left (toward the spark plug end) to increase engine R.P.M. (diag. 36).

NOTE: Be sure that the throttle cable has full travel from wide open throttle to full choke. **Hard Starting** could result if the cable is not properly adjusted to allow for full choke.

Engine Speed and Mixture Adjustments - *continued*

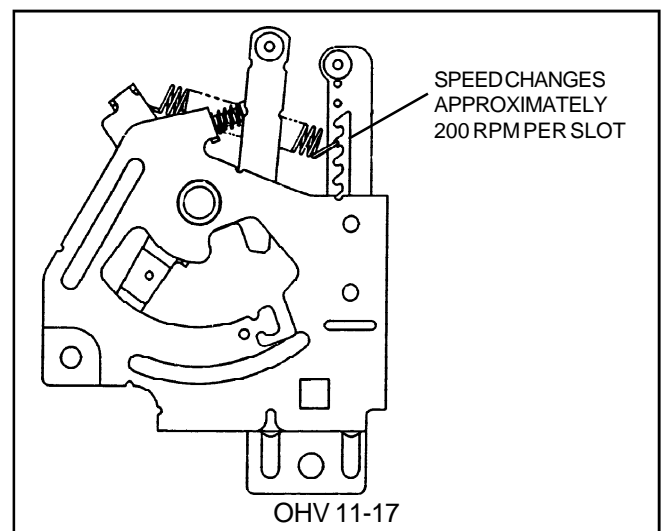
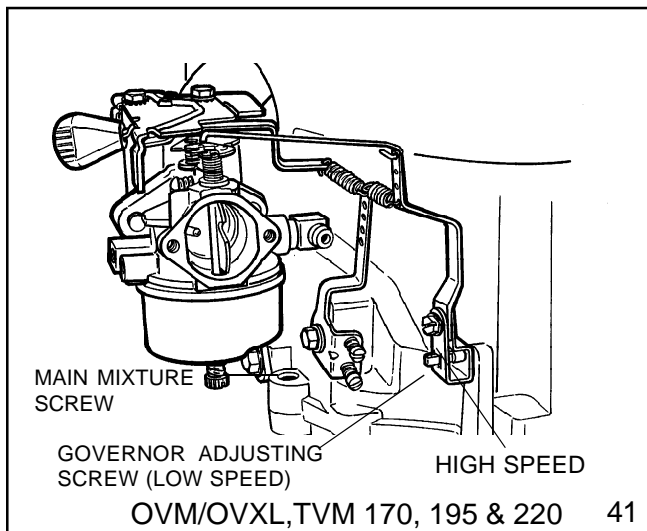
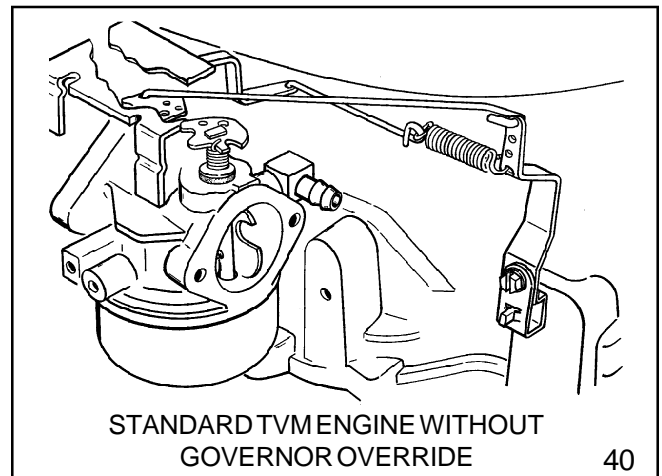
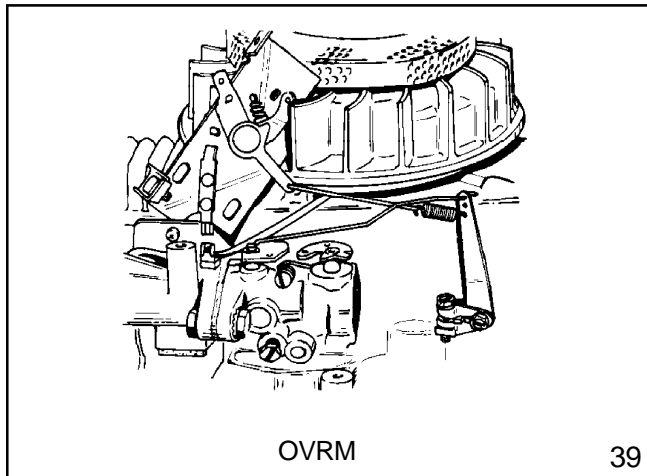
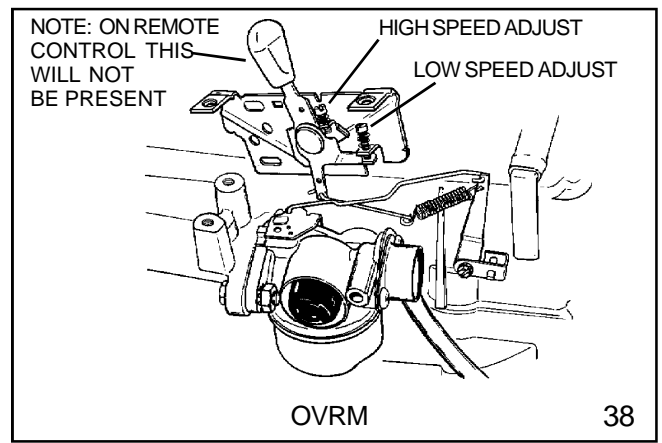
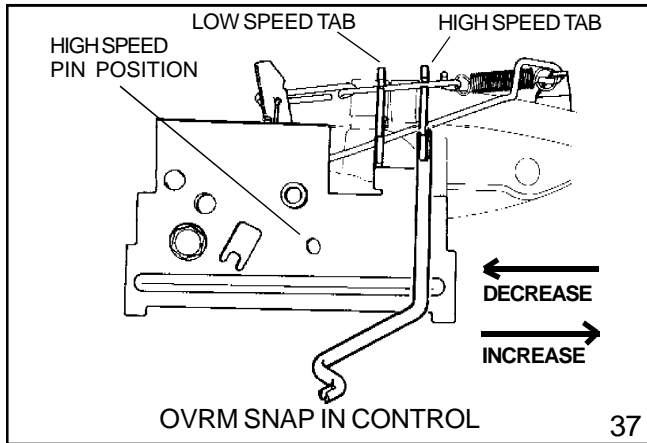

Governor Override System for TVM170, 195 and 220 Engines (diag. 41)

This system will be found starting on 1985 production models and will not retrofit onto older engines. It is designed to allow the governor to regulate the low and high speeds of the engine. The high speed is adjusted at the top screw of the override lever; to increase R.P.M. turn the screw out (counterclockwise), to decrease R.P.M. turn the screw in (clockwise). The low speed is adjusted at the bottom screw of the override lever; to increase R.P.M. turn the screw in or clockwise, to decrease R.P.M. turn the screw out or counterclockwise (diag. 41).

Engine Speed and Mixture Adjustments - Horizontal Shaft Engines

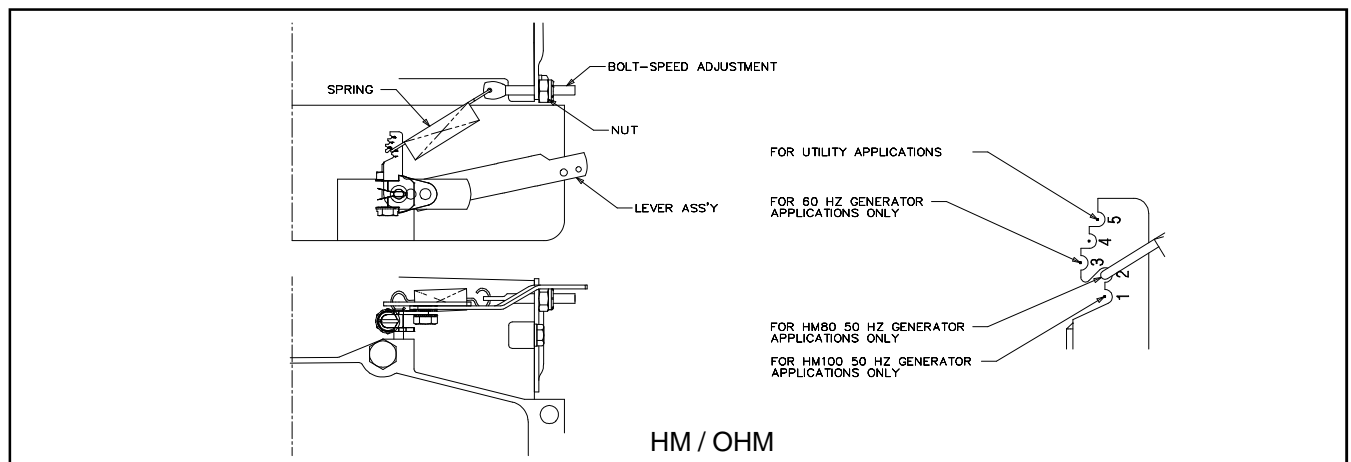
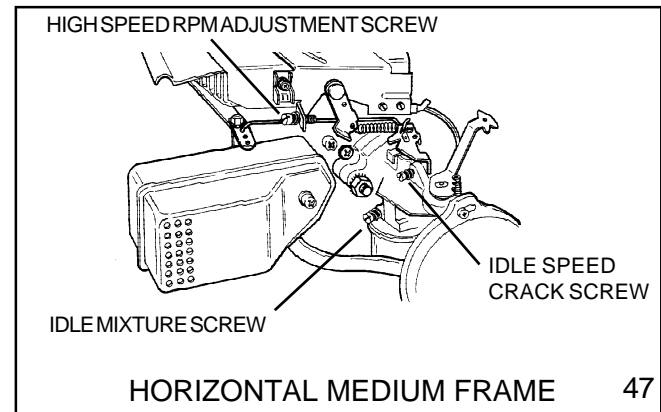
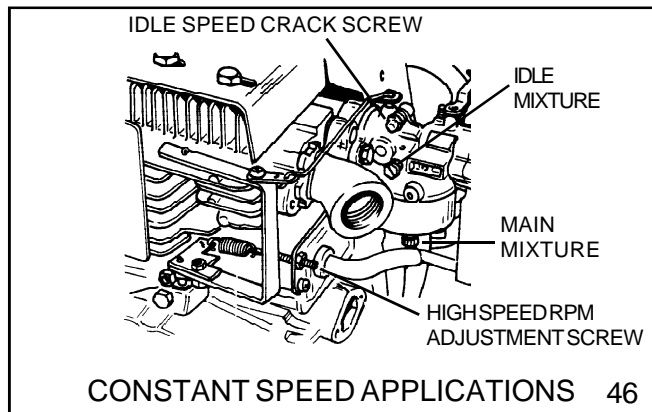
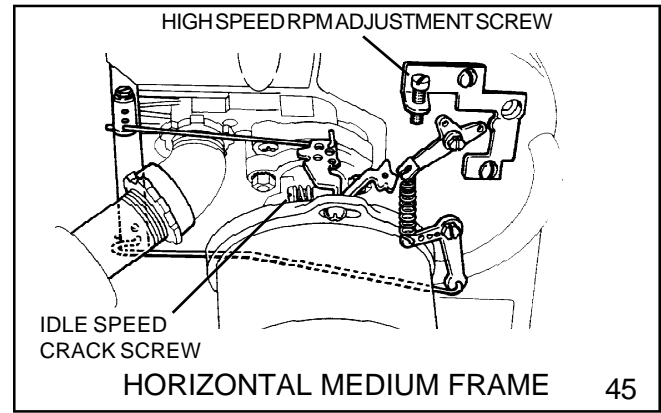
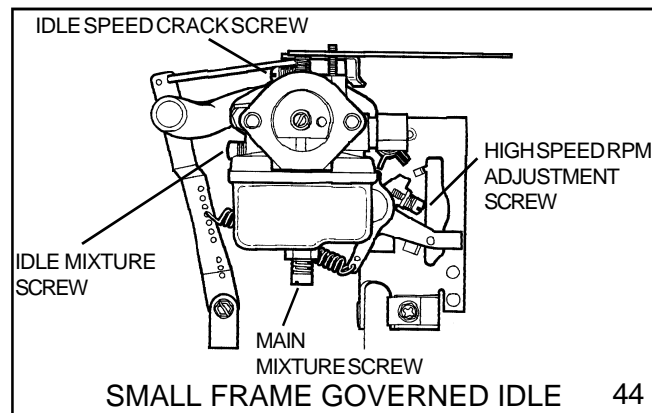
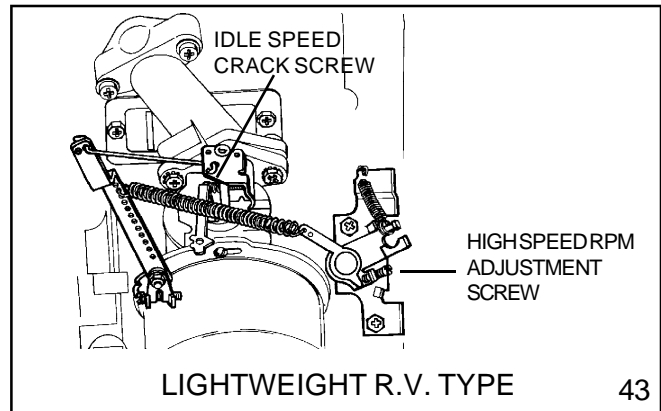
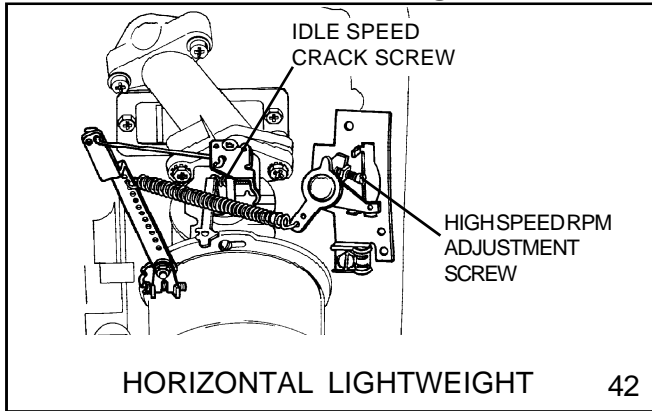

NOTE: Since 1996, all speed adjustment screws will have a torx head.

Horizontal Shaft Engines - *continued*

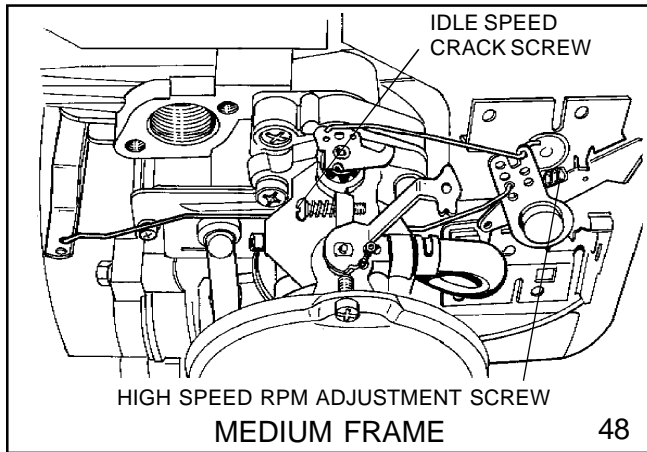

48

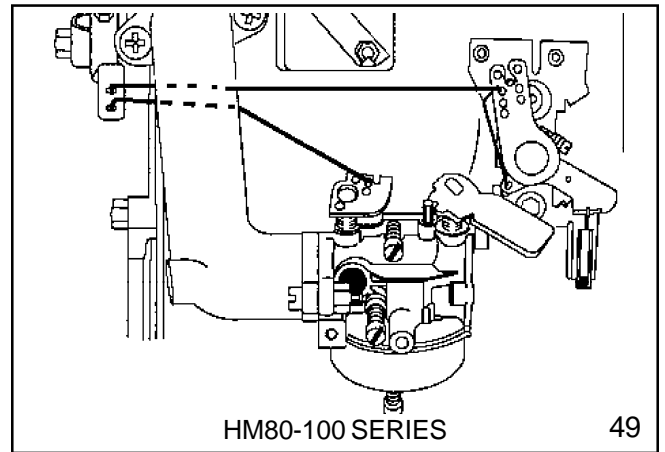

HM80-100 SERIES

49

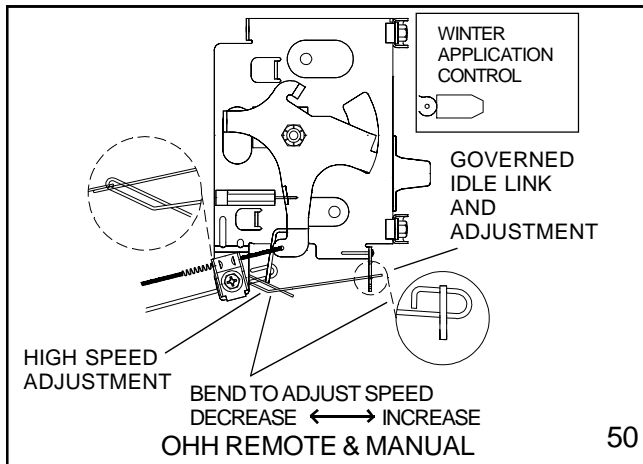

50

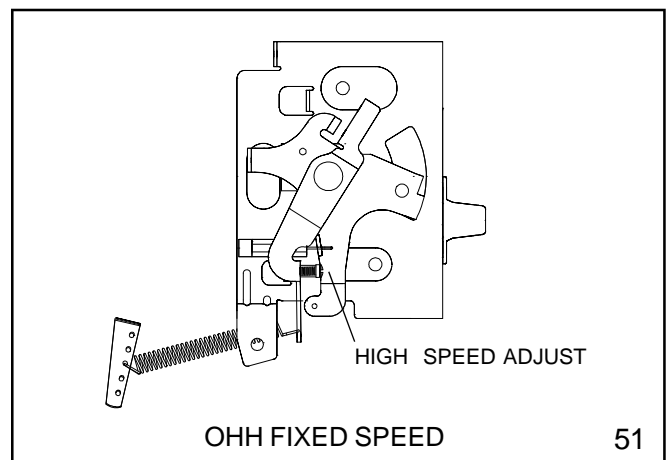

OHH FIXED SPEED

51

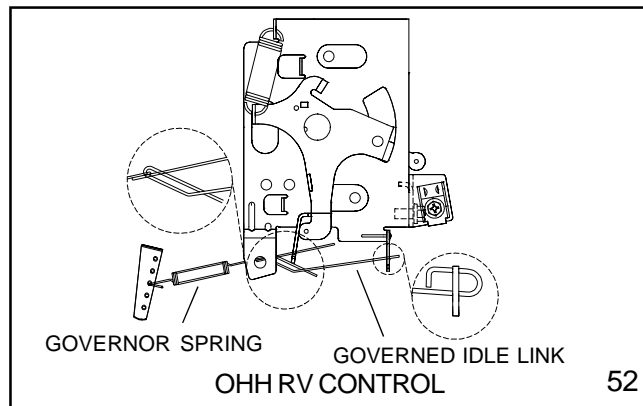

52

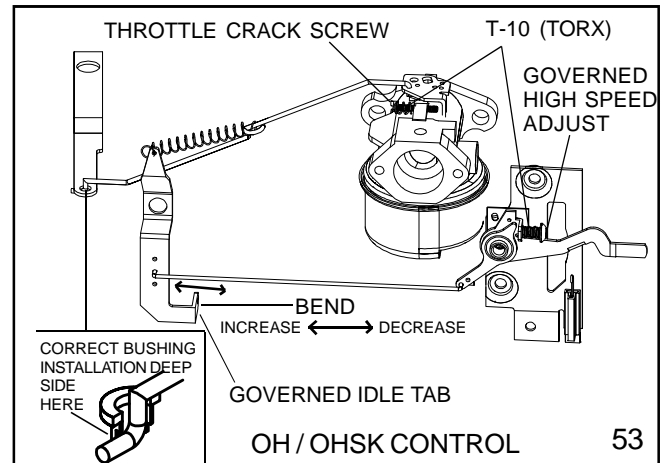

OH / OHSK CONTROL

53

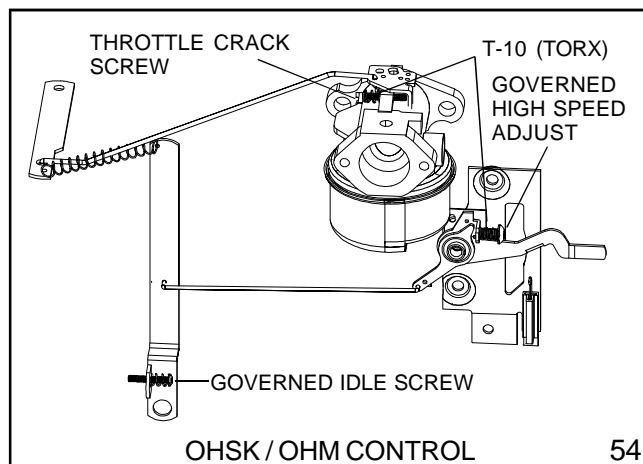

54

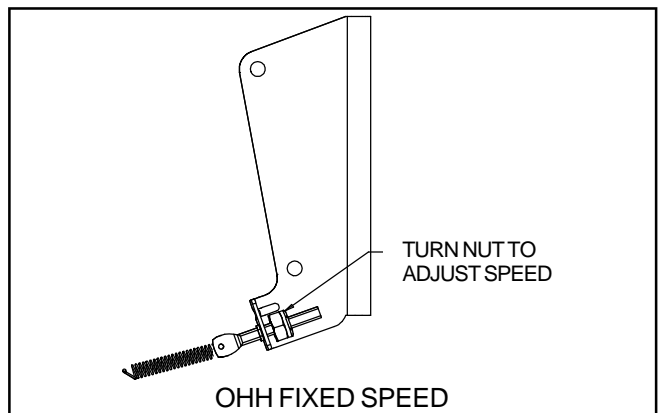

OHH FIXED SPEED

Engine Speed Adjustments - 8-18 HP, Cast Iron

Governor Adjustment for Horizontal Engines

Move the remote controls to the RUN position.

Loosen Screw "A".

Pivot plate "B" counterclockwise and hold.

Move lever "C" to left.

Tighten screw "A" securely.

When the governor is properly set the carburetor throttle lever will be in a wide open position when the controls are set for starting.

The governor spring is to be anchored in the bottom center hole (D) of plate "B". Do not stretch or cut the governor spring. Above adjustments will correct any variations in governor control (diag. 55).

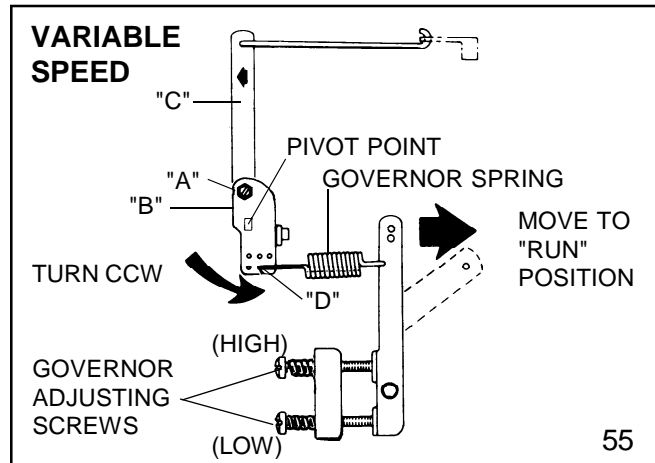

1. Setting Variable Speed Adjusting Screw.

Before attaching the bowden wire, set the engine for maximum R.P.M. (See Mfg. specifications) with engine running. Use a good tachometer. Move lever "A" clockwise until lower end strikes the adjusting screw at position "1" (diag. 56).

Loosen lock nut on adjusting screw and turn in to decrease R.P.M. Turn out to increase R.P.M.

CAUTION: DO NOT EXCEED RECOMMENDED R.P.M.

2. **Adjusting Fixed Speed.** The fixed speed adjusting screw is the optional position "2". Adjust it by starting the engine, then loosening the locknut. Turn the screw in to increase R.P.M. and out to decrease R.P.M.

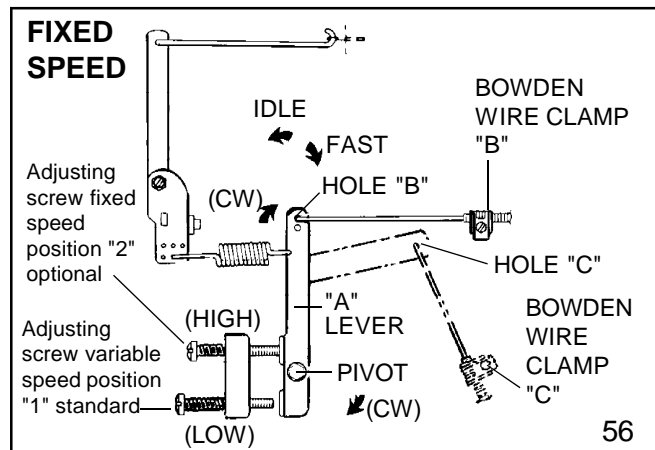

NOTE: The TVT-control system is shown only in the 696325 Technician's manual.

Switches, Sensors, and Solenoids

Low Oil Shutdown Switches

Check the LOS switch while it is in the engine. The engine must be level, and the oil level at the full mark. Place the speed control in the run position. Remove the spark plug wire from the spark plug. Install a gap type tester connected to the spark plug wire and a good engine ground. Spin the engine over using the electric or recoil starter. A bright blue spark should be seen at the tester. If not, remove the blower housing and disconnect the LOS lead from the ignition module. Reinstall the blower housing and spin the engine over. If spark occurs now, replace the LOS switch. If no spark is seen, replace the ignition module (diag. 57).

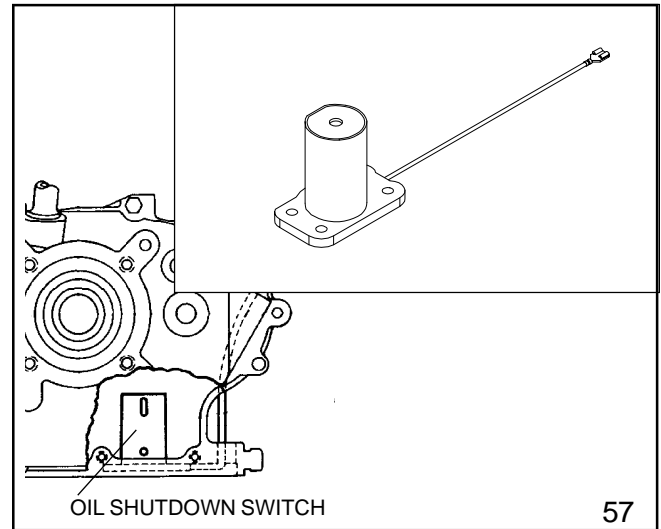

Low Oil Shutdown Indicator Light

If equipped, the indicator light will flash if the oil level is at or below the add mark when the engine is turned over while attempting to start. Test by turning the engine over with the oil level below the add mark. If the indicator light does not flash, replace the indicator light (diag. 58).

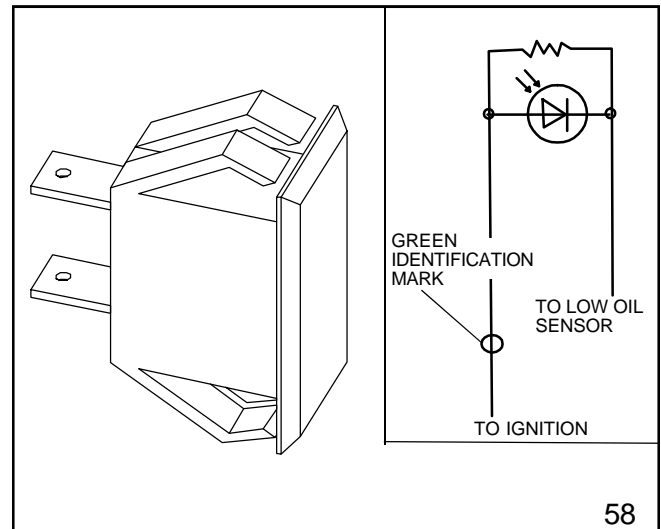

Low Oil Pressure Sensor

Test the sensor on a running engine using an ohmmeter or continuity tester with one test lead connected to the sensor terminal and the other to an engine ground. An open circuit should be found with the engine running and continuity should exist when the engine is shut off. If continuity is found or the oil pressure indicator is on at low engine R.P.M.'s, remove the sensor and install a master oil pressure gauge. The oil pressure of a running engine should be 7 p.s.i. (.500 bar) or higher, if lower an internal engine problem exists (diag. 59).

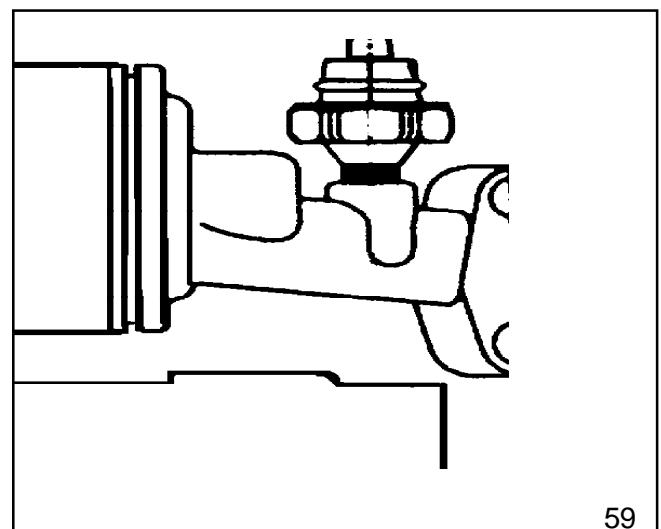

Switches, Sensors, and Solenoids - *continued*

Low Oil Sensor

This sensor must use a #194 bulb, resistance of the bulb **MUST** be .27 ampere in series with the sensor for proper operation and to prevent sensor damage. Remove the sensor from the engine and attach the electrical plug. Attach a jumper lead from an engine ground to the threaded portion of the sensor. Place the keyswitch in the run position. The indicator light should come on with the tip of the sensor in air (uncovered) and go off when oil covers the sensor tip. The response time of the sensor is between 5 and 15 seconds with 13 volts D.C. at the battery. Lower battery voltage will result in a longer response time. Use teflon-type pipe sealant on the sensor threads to prevent oil leakage when reinstalling (diag. 60).

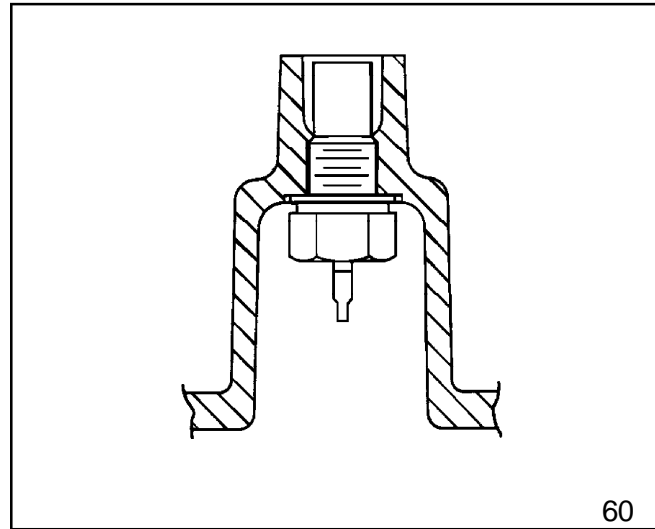

Fuel Shutdown Solenoids

If the engine is running, the solenoid can be checked by removing the electrical plug-in at the base of the solenoid. Almost immediately the engine should shutdown, if not replace the solenoid (diag. 61).

Test the solenoid off the carburetor by applying 12 volt D.C. from the battery positive terminal to a solenoid terminal. Connect a jumper wire from the metal housing (or other terminal) to a negative battery terminal. The plunger should retract the full travel distance. Disconnect the negative jumper lead and the plunger should return to the extended position. Replace if necessary (diag. 61).

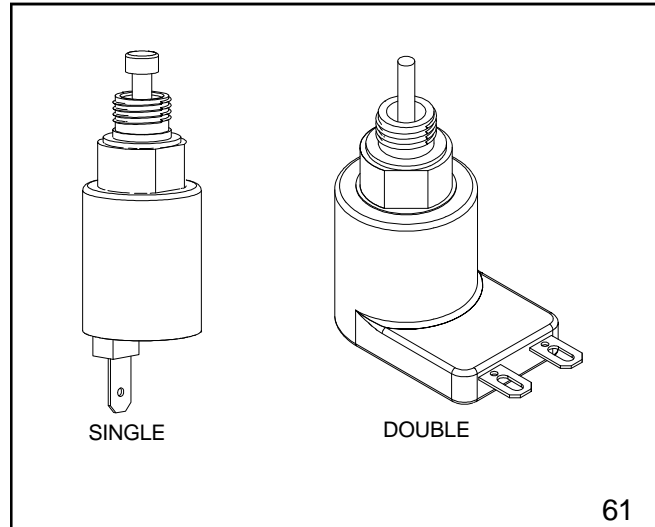

On/Off Switches

Engine On/Off Rocker Switch

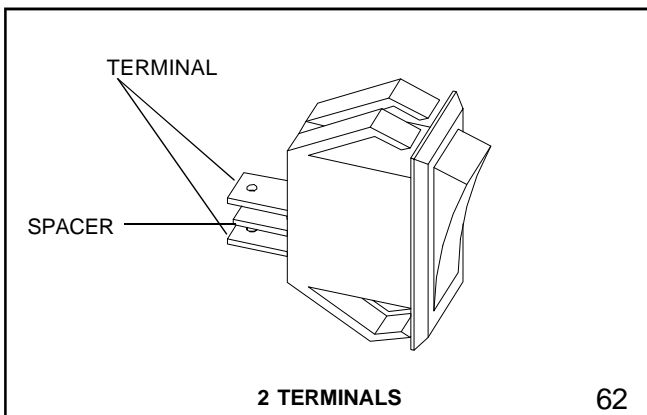

Lighted Engine On/Off Rocker Switch w/ Low Oil Shutdown

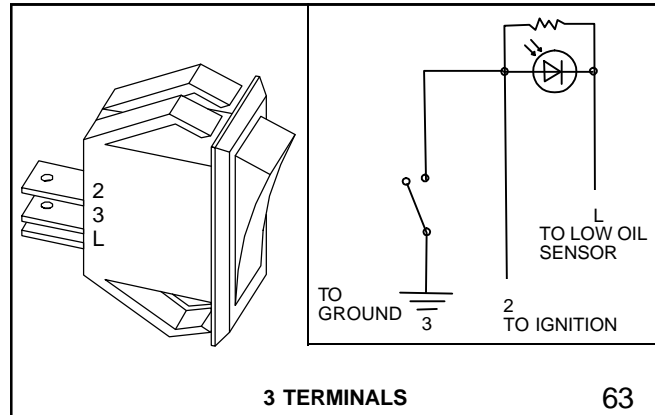

Wiring

CONDITION. All wiring must be fully insulated between connection points, securely fastened and free of foreign material (such as rust and corrosion) at the connection points. This is especially important in the use of batteries where much of the potential may be lost due to loose connections or corrosion. Remember to check the insulation on the wire. All it takes is a pin hole for a wire to "ground out" on the engine or frame. This is of special concern when moisture or water is present. This may cause the engine to run erratically or be impossible to start.

WIRE GAUGE: Proper thickness of wire is necessary in all electrical circuits. Wire diameter is measured in increments of gauge numbers. The larger the number, the smaller the diameter of the wire. The smaller the number, the larger the diameter of the wire.

1. Starter circuit wiring must be rated at #6 or lower gauge number.
2. Charging circuit wiring must be rated at #16 or lower gauge number. (20 amp system requires #14 or lower gauge number).
3. Magneto circuit wiring (ground circuit) must be rated at #18 or lower gauge number.

Color Codes

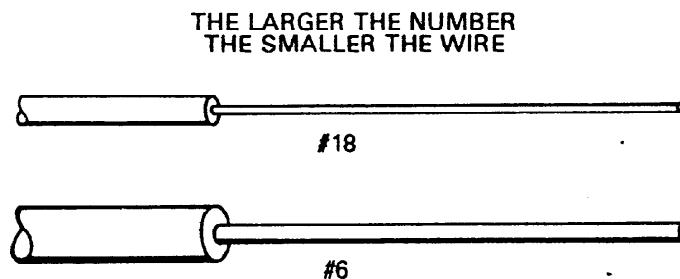

Tecumseh Products Company standard wiring color codes effective August, 1992 are as follows:

Code	Product
Yellow	- Alternator A.C. Leads
Red	- Alternator D.C. + Leads
Brown	- Alternator D.C. - Leads
Black	- Alternator Ground Leads, Battery Ground Leads
Orange	- 12 Volt Starter B + Leads
Dark Green	- Ignition Shut-Off Leads

NOTE: Prior to August 1992, wire codes changed according to model and specification numbers.

Ammeters

An ammeter is used to measure the rate of current flow from the alternating system to the battery. If no current flow is indicated by the ammeter, remove the ammeter from the circuit and check all other components in the system. Use the ohmmeter to check continuity across the ammeter. If no continuity exists, replace the ammeter.

Diodes

In order to charge a battery it is necessary to convert alternating current (A.C.) to direct current (D.C.) This is accomplished by using a diode or rectifier. Using a single diode will make use of one half of the A.C. signal and is known as HALF WAVE RECTIFICATION. This is acceptable in certain applications. In certain situations it is necessary to make use of the entire A.C. signal. To accomplish this we use multiple diodes in a bridge configuration which produces FULL WAVE RECTIFICATION.

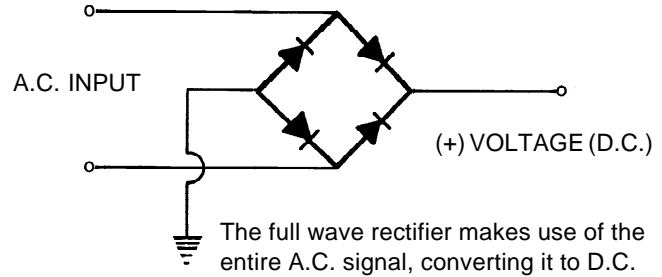
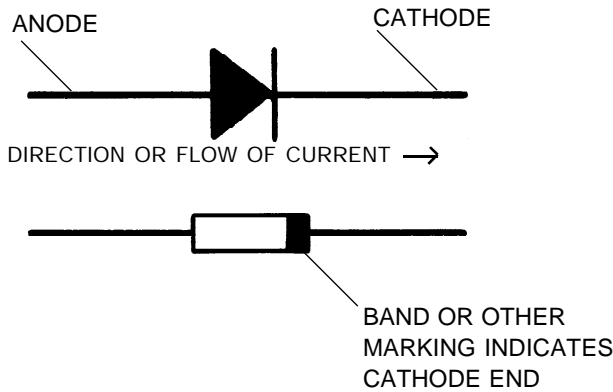

Solenoids

A solenoid is a heavy duty switching mechanism used to handle large amounts of current. It consists of a heavy strip of metal activated by an electromagnet. The metal strip connects two contact points and "makes" or "breaks" the electric circuit. Because the metal strip is heavier than most switch contacts, it does not pit or burn away as lighter switch contacts will.

To test a grounded solenoid, connect positive (+) solenoid terminal (next to solenoid ground) to the positive (+) battery terminal. Connect negative ground (-) terminal of the solenoid to the negative (-) battery terminal. If solenoid is in good condition, the plunger will "snap" and close the main contacts (diag. 64).

NOTE: With a grounded solenoid, battery B+ is supplied to activate. With insulated solenoid, battery B- is supplied to activate.

To test an insulated solenoid, connect the terminal marked "B" to the positive (+) battery terminal. Connect terminal marked "G" to the negative (-) battery terminal. If the solenoid is in good condition, the plunger will "snap" and close the main contacts.

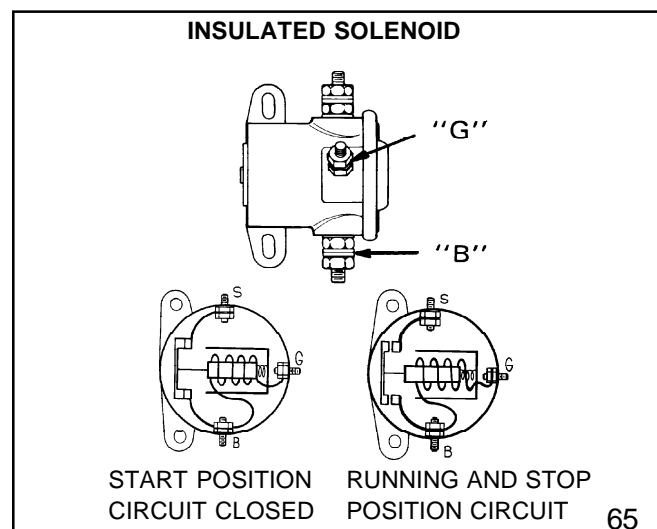
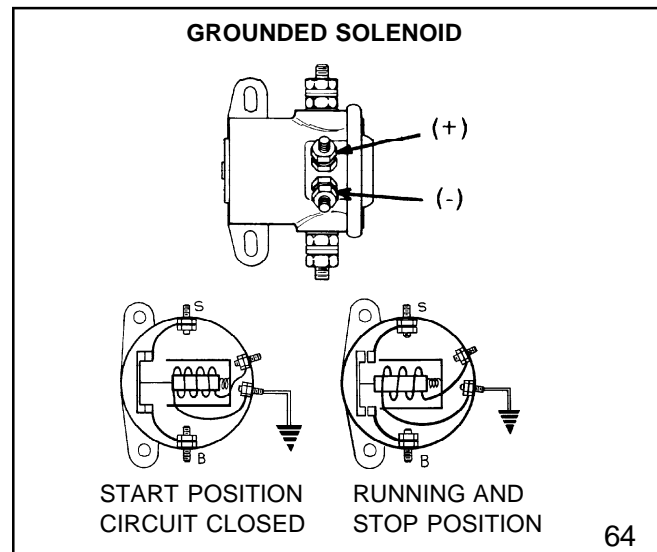

Key Switches

Switches are the common point on the vehicle where most of the wiring centrally comes together. There are many varieties of switches available. Replace damaged or failed switches according to the equipment manufacturer's specifications. NEVER substitute an automotive switch for a switch replacement on a small engine application, or a switch from an engine with a battery ignition.

The more common switches are shown below:

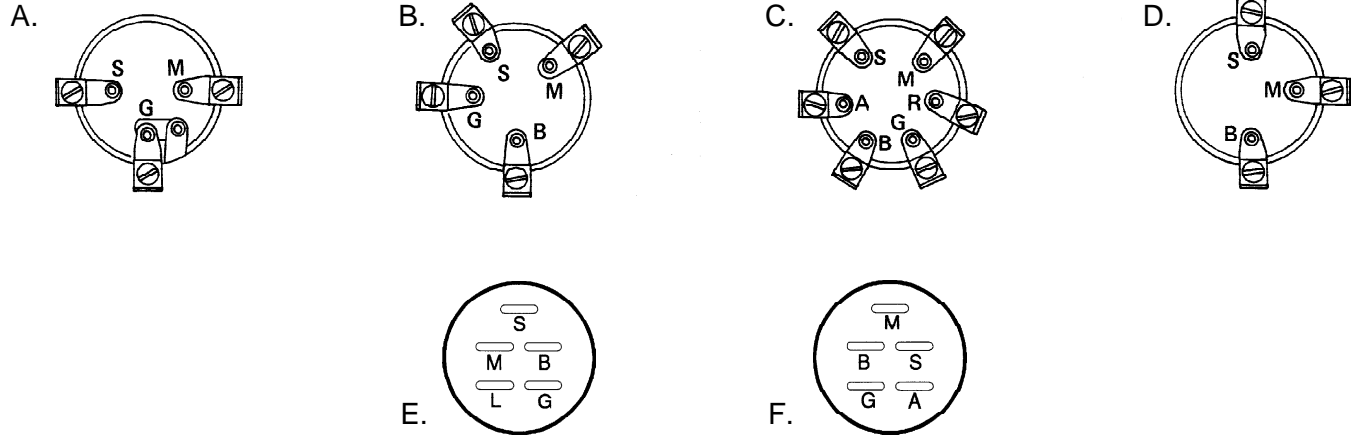

IMPORTANCE OF USING CORRECT SWITCH

Some switches are too small to take the continual "make" and "break" without burning the electrical contacts. This is when it is advisable to install the recommended manufacturers switch.

*****NOTE:** WARRANTY IS VOID FOR THE ENGINE COMPONENTS BEING BURNED OUT DUE TO A FAULTY SWITCH.

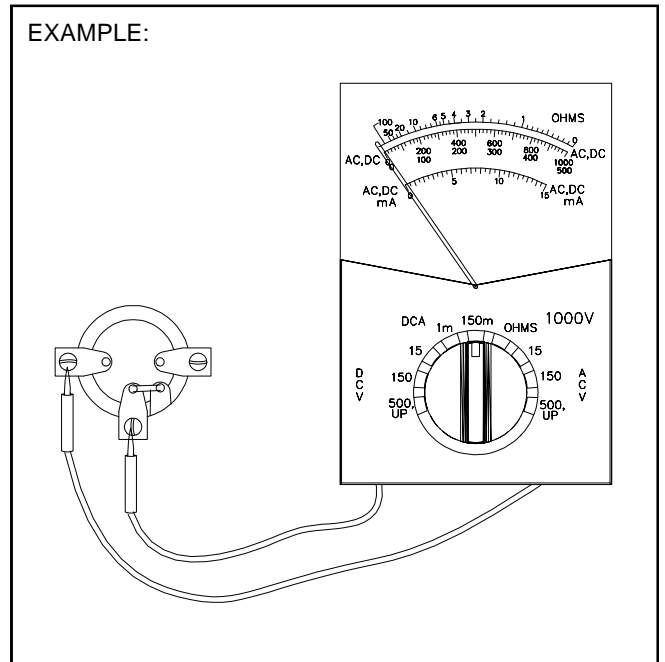

Continuity Check for Switches

NOTE: This is only a generic test, manufacturer's may differ in switch terminals and functions.

Continuity w / key
in start position

Continuity w / key
in off position

NO Continuity in
any key position

Continuity w / key
in run position

Continuity w / key
in start position

Continuity w / key
in off position

NO Continuity in
any key position

Continuity w / key
in run position

Switch A				
Connect Ohmmeter Leads to:				
S & G	X			
M & G		X		
M & S			X	
Switch B (metal case)				
Connect Ohmmeter Leads to:				
S & G			X	
S & B	X			
S & A, S & metal case			X	
M & B			X	
M & A, M & metal case		X		
B & A				X
B & metal case			X	
A & metal case		X		
with 5th terminal				
R & S, R & M			X	
R & B, R & A				X
R & metal case			X	
Switch C				
Connect Ohmmeter Leads to:				
A & S			X	
A & M, A & G (3)		X		
A & R, A & B				X
S & M, S & R, S & G (3)			X	
S & B	X			
M & R, M & B			X	
M & G (3)		X		
R & G (3)			X	
R & B				X
B & G (3)			X	

Switch D (metal case)				
Connect Ohmmeter Leads to:				
S & B	X			
M & Switch Case		X		
M & B			X	
M & S			X	
Switch E				
Connect Ohmmeter Leads to:				
M & S			X	
M & B			X	
M & G		X		
M & L			X	
S & B	X			
S & G			X	
S & L	X			
G & L			X	
B & G			X	
B & L	X			X
Switch F				
Connect Ohmmeter Leads to:				
A & G		X		
A & B				X
A & M			X	
A & S			X	
G & B			X	
G & M		X		
G & S			X	
B & M			X	
B & S	X			
M & S			X	

350 Milliamp

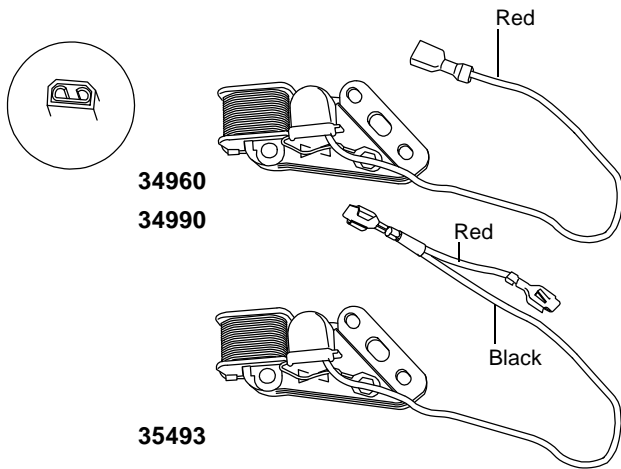

1 AMP (18 WATT) A.C. - ADD-ON ALTERNATOR

611077 (Alternator Only)

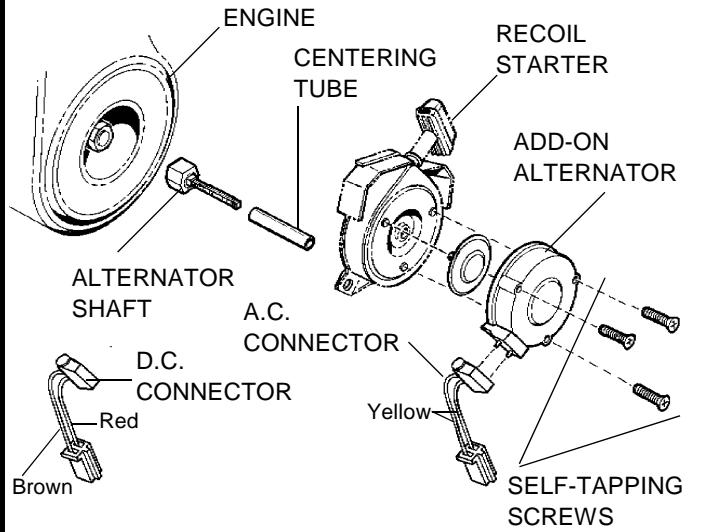

18 Watt A.C. Lighting

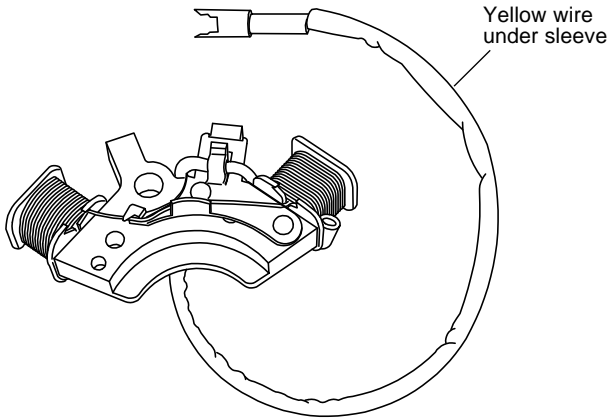

3 Amp A.C.

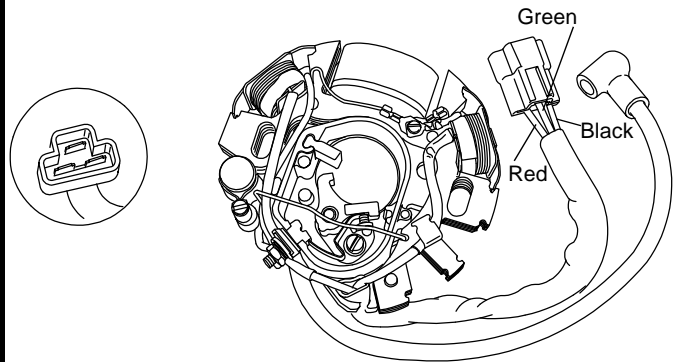

61111

610981

3 Amp D.C.

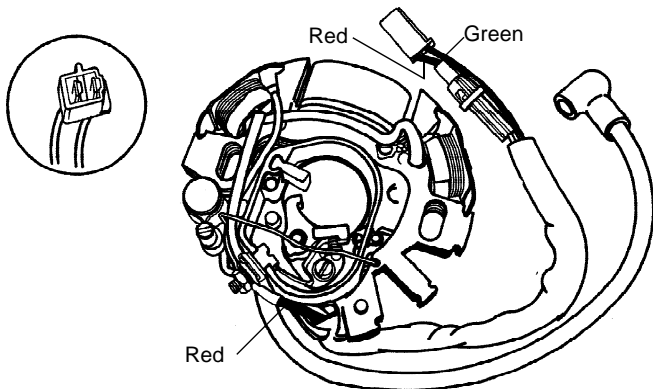

610968

3 Amp A.C.

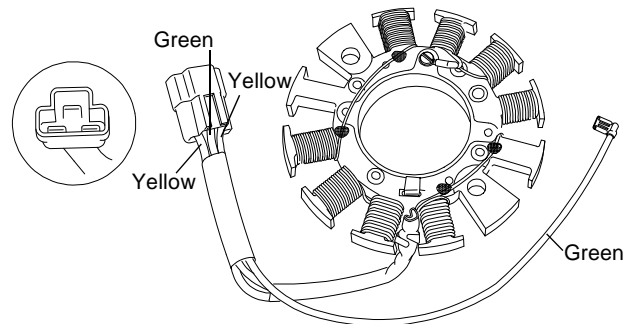

611095

Yellow - Alternator A.C. Leads	Black - Alternator Ground/Battery Ground
Red - Alternator D.C. (+) Leads	Orange - 12 Volt Starter (+) Leads
Brown - Alternator D.C. (-) Leads	Dark Green - Ignition Shut-off Leads

Charging System

Charging System - *continued*

2 and 3 Amp D.C.



3 Amp

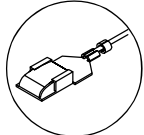

2 Amp

(requires optional flywheel)

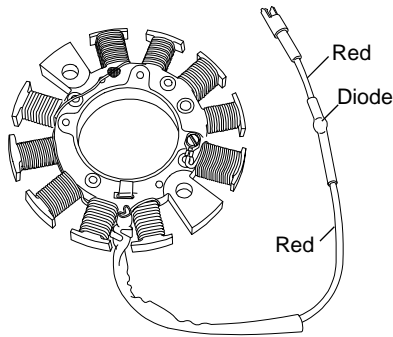

611116 (3 Amp)

3 Amp D.C.

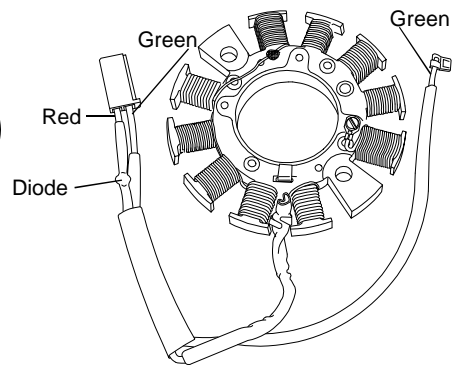

611113

3 Amp D.C. - 5 Amp A.C.

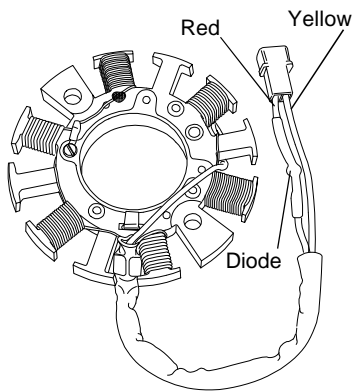

611104

5 Amp D.C.

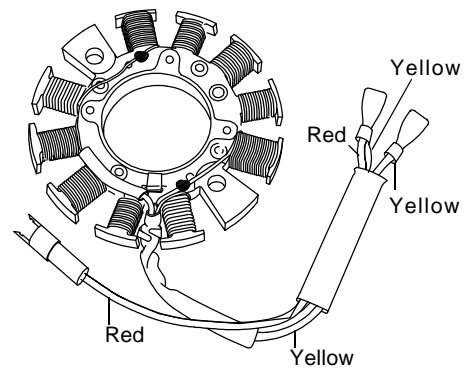
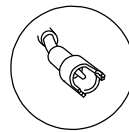

611176

* Uses regulator / rectifier 611175A

7 Amp D.C.

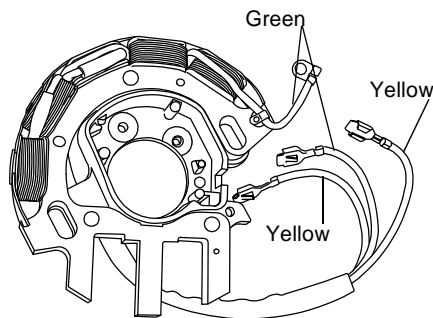

610818

* Uses regulator/rectifier 610749

7 Amp D.C.

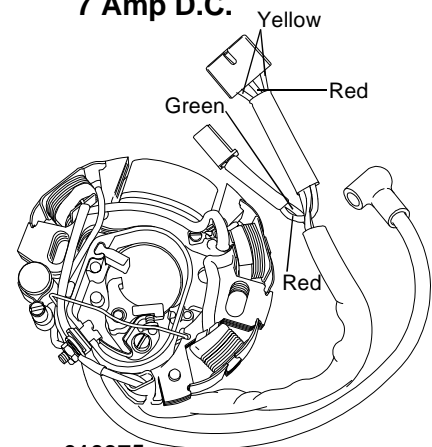
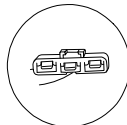
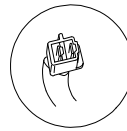

610975

* Uses regulator / rectifier 610938

Yellow - Alternator A.C. Leads	Black - Alternator Ground/Battery Ground
Red - Alternator D.C. (+) Leads	Orange - 12 Volt Starter (+) Leads
Brown - Alternator D.C. (-) Leads	Dark Green - Ignition Shut-off Leads

Charging System - *continued*

7 Amp D.C.
611097

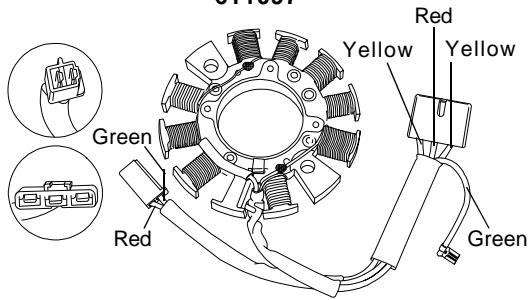

* Uses regulator/rectifier 611098; an open circuit D.C. voltage check cannot be made.

7 Amp D.C.
611256

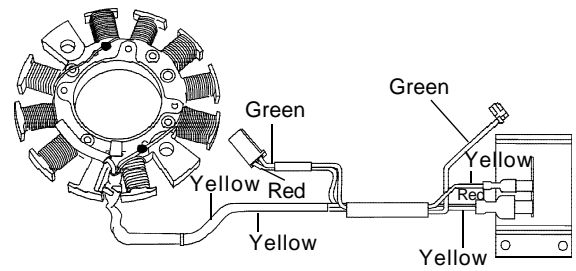

10 Amp D.C.
610761

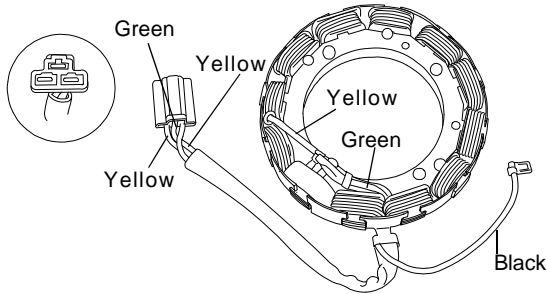

* Uses regulator/rectifier 610749

10 Amp Alternator
611159

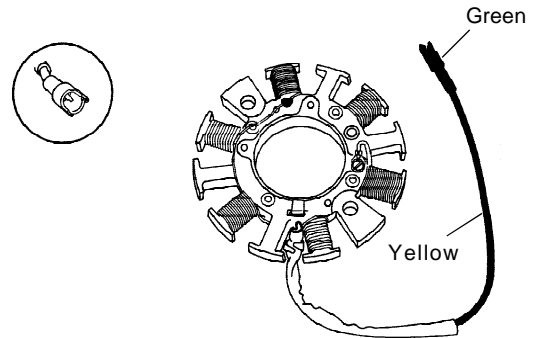

12 Amp D.C.

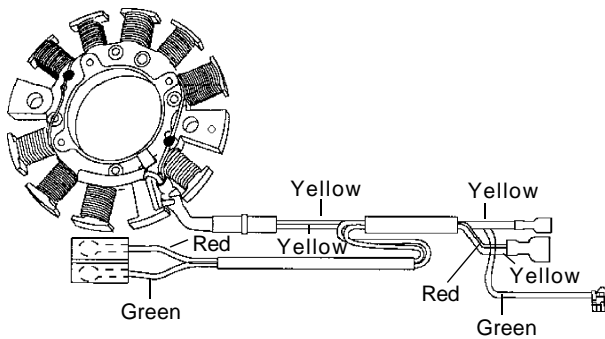

20 Amp Alternator
610902

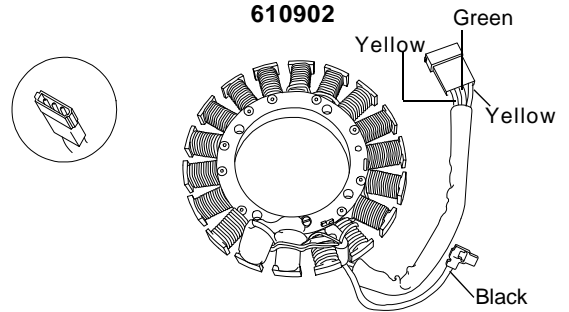

* Uses regulator/rectifier 610996 or 610907A; depending on spec number an open circuit D.C. voltage check cannot be made.

Regulator/Rectifiers

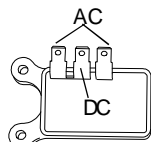

7 Amp
611098

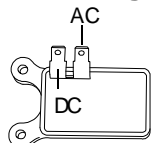

5 Amp, 7 Amp
611175

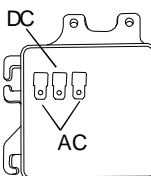

7 Amp
610938

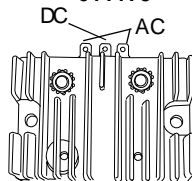

7 Amp, 10 Amp
610749

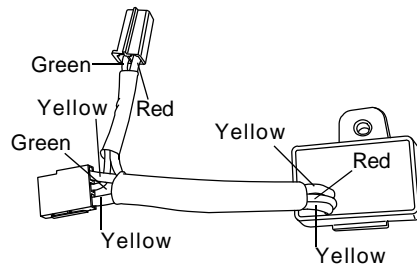

20 Amp
610996
610907A

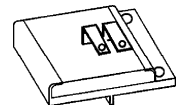

5 Amp, 7 Amp
611175A

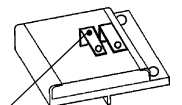

12 Amp
611274

Yellow - Alternator A.C. Leads
Red - Alternator D.C. (+) Leads

Brown - Alternator D.C. (-) Leads
Black - Alternator Ground/Battery Ground

Orange - 12 Volt Starter (+) Leads
Dark Green - Ignition Shut-off Leads

CAUTION: When testing Alternator/Charging System:

DO NOT disconnect positive lead(s) from the battery while the engine is running. With the engine stopped, disconnect lead(s), then perform test and stop engine before re-connecting. Connecting or disconnecting while the engine is running will send a voltage surge through the regulator, causing damage.

Testing Procedures

D.C. Charging Adaptor

Rectifier Bridge Check With Ohmmeter for D.C. Adaptor

Continuity should exist during one of the two following tests. No continuity should exist while performing the opposite test.

If continuity exists during both tests, or if no continuity exists during both tests, the D.C. adaptor is defective.

TEST NO. 1 - Connect negative probe of meter to red output lead. Connect positive probe of meter to both A.C. terminals and black output lead (diag. 66).

2000 R.P.M. - 8.0 Volts A.C.

3000 R.P.M. - 10.5 Volts A.C.

3600 R.P.M. - 12.0 Volts A.C.

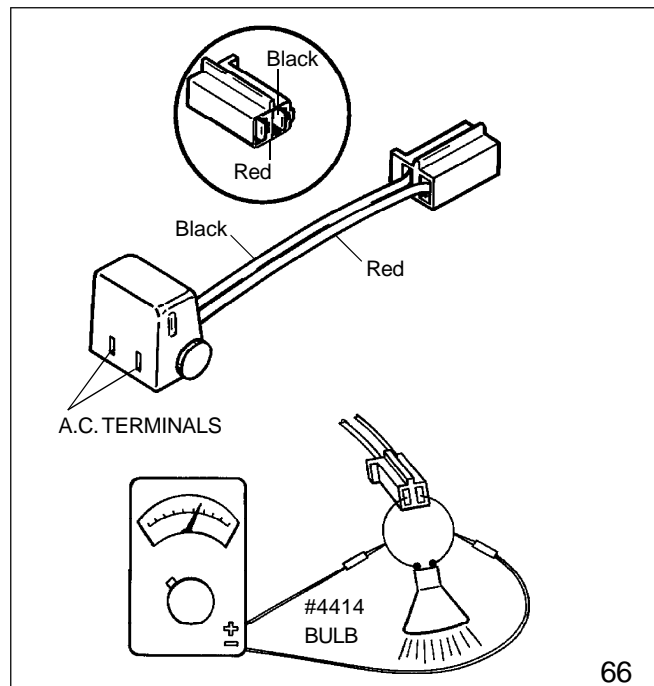

TEST NO. 2 - Connect positive probe of meter to red output lead. Connect negative probe of meter to both A.C. terminals and black output lead.

Connect negative probe of meter to black output lead. Connect positive probe of meter to both A.C. terminals and red output lead.

If the D.C. adaptor is not defective and a known good battery fails to hold a charge, then perform an A.C. output voltage test.

NOTE: PRIOR TO AUGUST 1992, THE BLACK WIRE WAS BROWN.

CHECKING THE SYSTEM: To check the system, disconnect the D.C. adaptor from the add-on alternator. Connect a No. 4414, 18 watt bulb in line with each terminal in the alternator. Start engine and test circuit using an A.C. voltmeter as shown.

With the engine running, minimum A.C. voltage values across the bulb should be:

2000 R.P.M. - 8.0 Volts A.C.

3000 R.P.M. - 10.5 Volts A.C.

3600 R.P.M. - 12.0 Volts A.C.

If the minimum values are noted, alternator is okay. If the minimum values are not noted, the alternator or A.C. connector is defective.

350 Milliamp Charging System

CHECKING THE SYSTEM: The battery must be in the circuit to perform the test properly. Set the voltmeter to the 0-20 D.C. volt scale. Connect a voltmeter across the battery. The voltmeter should read battery voltage. Start the engine. With the engine running, there should be an increase in the voltage reading. If there is no change in the voltage reading, the alternator is defective and should be replaced (diag. 67).

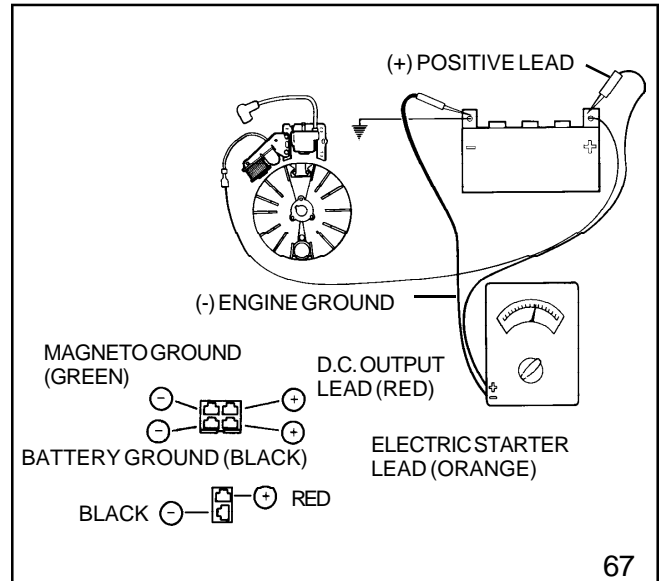

18 Watt A.C. Lighting Alternator Models H35, HS & HSSK 40-50, HM & HMSK 70-80-100

CHECKING THE SYSTEM: To check the system, disconnect the plug from the rest of the lighting system. Connect a wire lead from the single pin connector coming out of the engine to one terminal of a No. 4414, 18 watt bulb. Connect another wire to the remaining terminal of the bulb and run it to a good ground on the engine. Start the engine and test the circuit using the A.C. voltmeter as shown (diag. 68).

With the engine running the minimum A.C. voltage across the bulb should be:

2000 R.P.M. - 6.0 Volts A.C.

3000 R.P.M. - 8.5 Volts A.C.

3600 R.P.M. - 10.0 Volts A.C.

If minimum values are noted, the alternator is okay. If less than the minimum values, the alternator is defective.

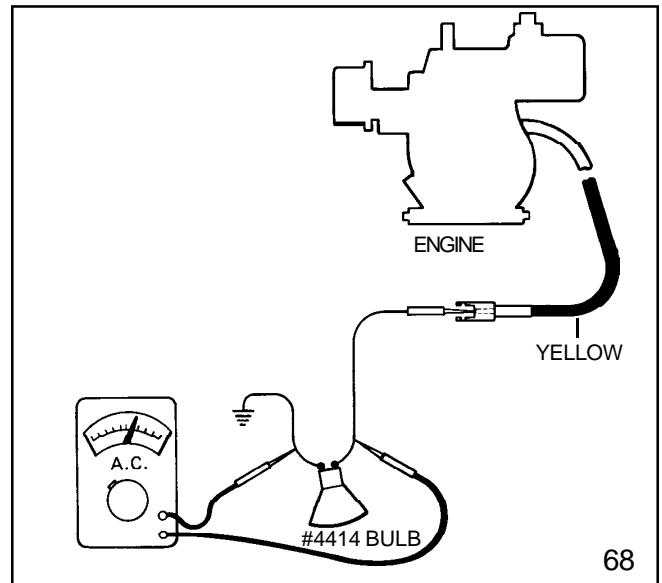

35 Watt A.C.

Before making any exterior tests, check for an inoperative switch, shorted wires and burned out headlight and/or stop tail light. To check out the alternator, check the A.C. lead to ground at each yellow wire (diag. 69).

With engine running, minimum values should read:

2500 R.P.M. - 8.0 Volts A.C.

3000 R.P.M. - 9.5 Volts A.C.

3300 R.P.M. - 10.5 Volts A.C.

3600 R.P.M. - 11.5 Volts A.C.

If the above minimum readings are noted, the alternator is okay. Check for defective lights, wiring or switches, if less than the above readings, the alternator is defective.

NOTE: ON OLDER POINT IGNITION SYSTEMS, THE A.C. OUTPUT LEADS ARE BLACK AND RED.

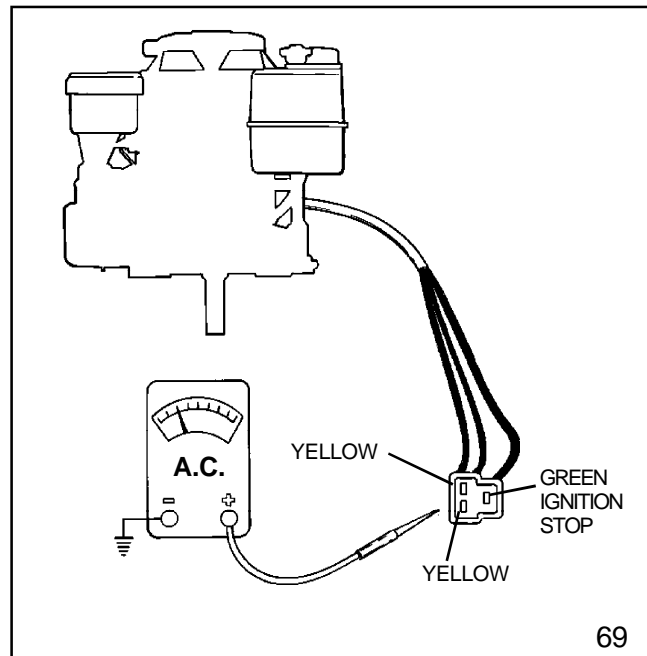

1 Amp (18 Watt) Add-on Alternator

CHECKING THE SYSTEM: To check the system, disconnect the plug from the rest of the lighting system. Connect a No. 4414, 18 watt bulb in line with each terminal in the plug. Start the engine and test the circuit using a voltmeter as shown (diag. 70).

With the engine running the minimum A.C. voltage values across the bulb should be:

2000 R.P.M. - 8.0 Volts A.C.

3000 R.P.M. - 10.5 Volts A.C.

3600 R.P.M. - 12.0 Volts A.C.

If minimum values are noted, the alternator is okay. If the minimum values are not noted, the alternator or A.C. connector is defective.

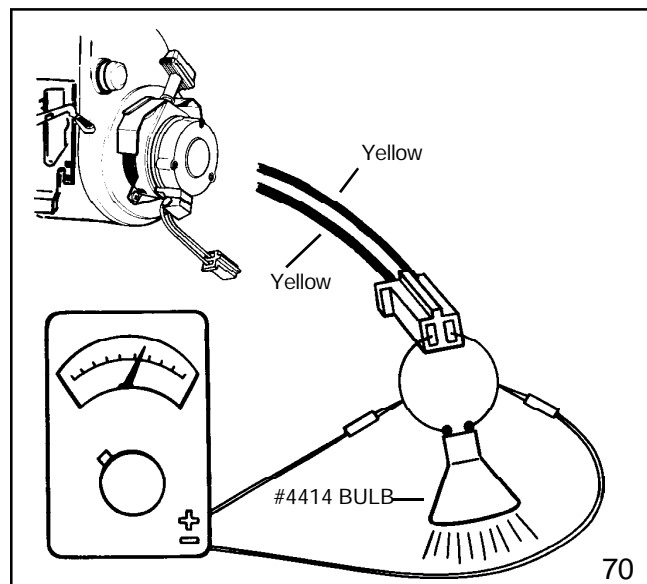

2.5 Amp D.C., 35 Watt Lighting

If output is below standard listed, pull back protective coating in front of the diode and check A.C. output. If A.C. is good check each diode it services as required (diag. 71).

D.C. value (+) or (-); check both sides of A.C. outputs.

R.P.M. D.C. Volts

2500 - 8.0 Volts D.C.

3000 - 9.5 Volts D.C.

3300 - 10.5 Volts D.C.

3600 - 11.5 Volts D.C.

R.P.M. Volts A.C.

2500 - 18 Volts A.C.

3000 - 22 Volts A.C.

3600 - 26 Volts A.C.

NOTE: These minimum numbers should be obtained by your meter and will often be higher.

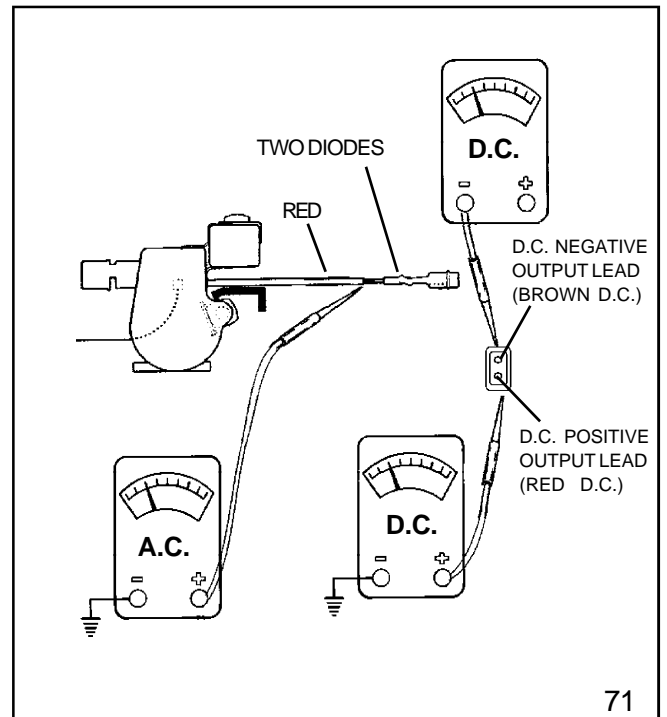

2 and 3 Amp DC Alternator System - Diode in Harness Models: H30-35, HS40, H50-60, HH50-60, HM70-80-100, HMSK, HHM80, HSK, HSSK, Rotary Mower Engines

This system has a diode included in the red wire which converts the alternating current (A.C.) to direct current (D.C.) is used to provide a trickle charge for the battery. The leads from the alternator and the type of connector may vary, but the output readings will be the same.

CHECKING THE SYSTEM: Remove the fuse (if equipped) from the fuse holder and check the fuse to make certain it is good. If faulty, replace with a six (6) AMP fuse.

To check D.C. output, separate the connectors at the engine. Place the probe (+) in the red wire lead connector. Ground the other probe to the engine (diag. 72).

With the engine running the minimum values should read:

2500 R.P.M. - 8.0 Volts D.C.

3000 R.P.M. - 9.5 Volts D.C.

3300 R.P.M. - 10.5 Volts D.C.

3600 R.P.M. - 11.5 Volts D.C.

If these minimum readings are noted, the system is okay. Check for bad battery, ammeter, wiring, etc.

(Continued on Next Page)

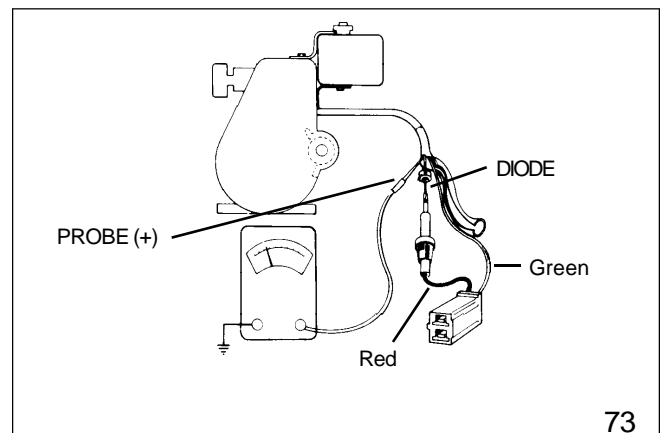
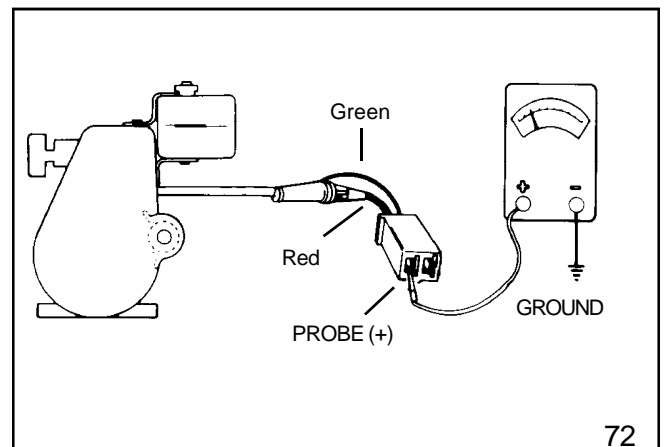

If less than the above readings, proceed in making an A.C. output check by pulling back the protective coating from the fuse holder and diode. Using an A.C. voltmeter, check voltage from a point between the engine and the diode as shown in the diagram (diag. 73).

With the engine running the minimum values should read:

2500 R.P.M. - 18.0 Volts A.C.

3000 R.P.M. - 22.0 Volts A.C.

3300 R.P.M. - 24.0 Volts A.C.

3600 R.P.M. - 26.0 Volts A.C.

If low or no voltage is experienced, replace the alternator. If the alternator puts out the minimum A.C. voltage, replace the diode.

3 Amp D.C. Alternator System - Rectifier Panel

This 3 amp system is readily identified by the rectifier panel in the circuit. The panel includes two diodes and a fuse for overload protection. The rectifier panel does not regulate the output of this system.

CHECKING THE SYSTEM: Check the fuse to determine if it is good. A continuity light or ohmmeter can detect a faulty fuse. Replace with a six (6) amp fuse if necessary. Determine if the diodes are functioning properly. A continuity light may be used to check diodes (diag. 74).

When replacing the diode in the rectifier panel, locate the undercut on one end of the diode and match it to the detent on terminal clip of the rectifier panel.

Test the D.C. output of the rectifier panel as follows:

Disconnect the battery lead from the terminal of the rectifier panel. Use a D.C. voltmeter probe on the + battery terminal (diag. 75). Connect negative lead to engine ground.

Minimum values should read:

2500 R.P.M. - 12.0 Volts D.C.

3000 R.P.M. - 14.0 Volts D.C.

3300 R.P.M. - 16.0 Volts D.C.

3600 R.P.M. - 18.0 Volts D.C.

If these minimum readings are noted, the system is okay. Check for bad battery, ammeter, wiring, etc.

If reading is less, proceed to make an A.C. output check. With the battery lead disconnected from rectifier panel, probe the A.C. terminals with the voltmeter on the A.C. scale (diag. 76).

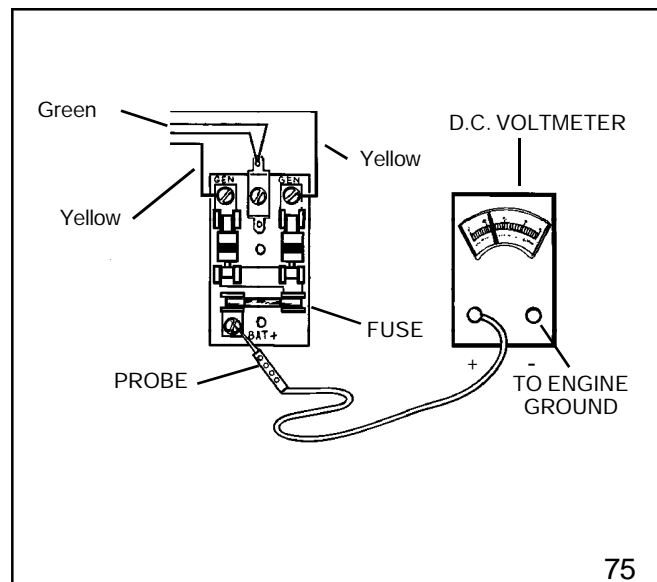
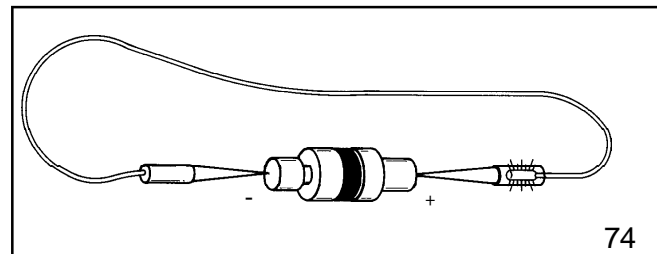

(Continued on Next Page)

Minimum values should read:
 2500 R.P.M. - 24.0 Volts A.C.
 3000 R.P.M. - 29.0 Volts A.C.
 3300 R.P.M. - 32.0 Volts A.C.
 3600 R.P.M. - 35.0 Volts A.C.

If less than above output, generating coil assembly is defective.

NOTE: If there is no regulator in this system. The total output of the two diodes is three (3) AMPS. If the battery is overcharging (boiling and bubbling), reduce the D.C. input by one-half by removing one of the diodes.

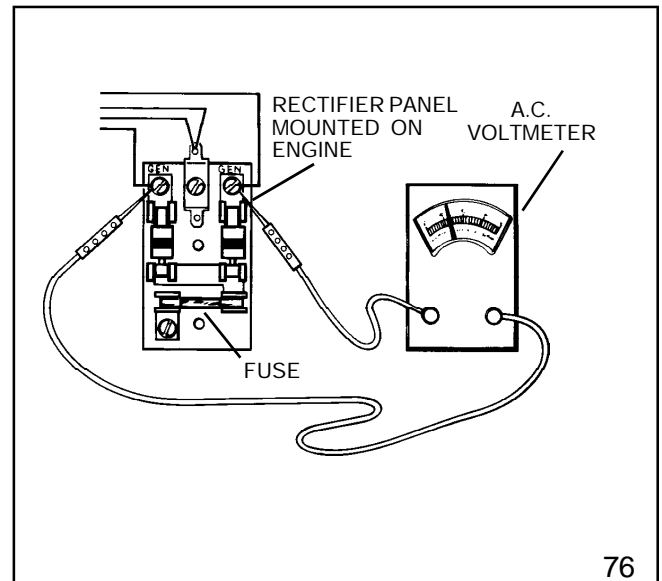

3 Amp D.C. 5 Amp A.C. Alternator Models OVM/OVXL 12.5, OHV12.5-17.0

This unit combines a 3 Amp D.C. system used to charge a battery and a 5 Amp A.C. system used for lighting. Located in the red wire of the harness is a diode which converts the alternating current to direct current for charging the battery. The yellow wire provides the A.C. voltage for the lighting circuit.

A wire harness (part# 36588) may be added to the 3 Amp D.C./5 Amp A.C. charging system to power an electric clutch without the use of a battery. Test the diode in the harness by doing a continuity test (diag. 77).

Replace the diode if continuity exists after reversing tester leads or if no continuity is found.

CHECKING THE SYSTEM: To check the system, disconnect the plug and measure the D.C. voltage at the red wire terminal (diag. 75). Measure the A.C. voltage at the yellow wire terminal. With the engine running the minimum values should be:

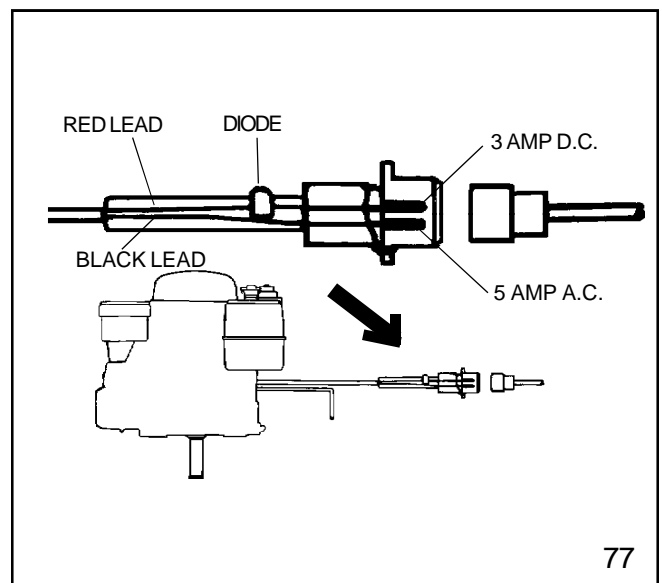

(Continued on Next Page)

MODELS OVM/OVXL/OHV

3 Amp D.C. (Red wire)

2500 R.P.M. - 8.0 Volts D.C.
3000 R.P.M. - 11.0 Volts D.C.
3600 R.P.M. - 13.0 Volts D.C.

5 Amp A.C. (Yellow wire)

2500 R.P.M. - 8.5 Volts A.C.
3000 R.P.M. - 11.0 Volts A.C.
3600 R.P.M. - 13.0 Volts A.C.

MODELS OHV 13.5 - 17.0 (3/5 Amp split)

3 Amp D.C. (Red wire)

2500 R.P.M. - 6.5 Volts D.C.
3000 R.P.M. - 9.0 Volts D.C.
3600 R.P.M. - 11.0 Volts D.C.

5 Amp A.C. (Yellow wire)

2500 R.P.M. - 15.0 Volts A.C.
3000 R.P.M. - 18.0 Volts A.C.
3600 R.P.M. - 22.0 Volts A.C.

If the above minimum values are noted, the system is okay. Check for defective lights, wiring or switches. If less than above values are noted, pull back the protective shrink tubing from the diode. Using an A.C. voltmeter, check the voltage between the alternator and diode as shown (diag. 79). If low or no voltage is experienced, replace the alternator.

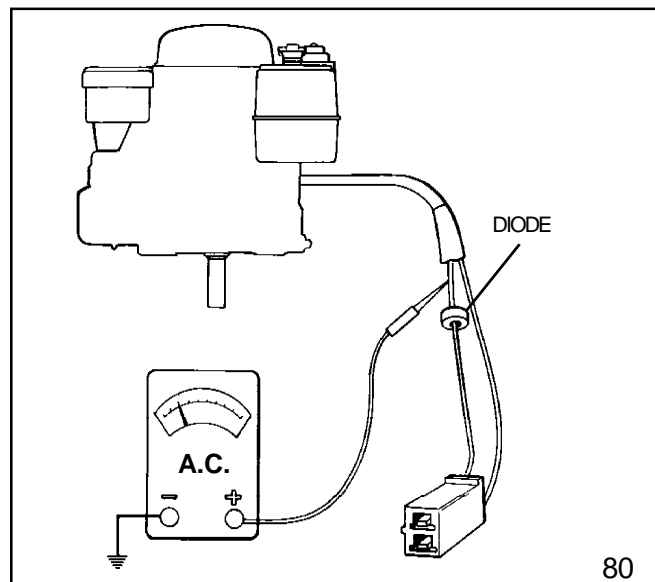
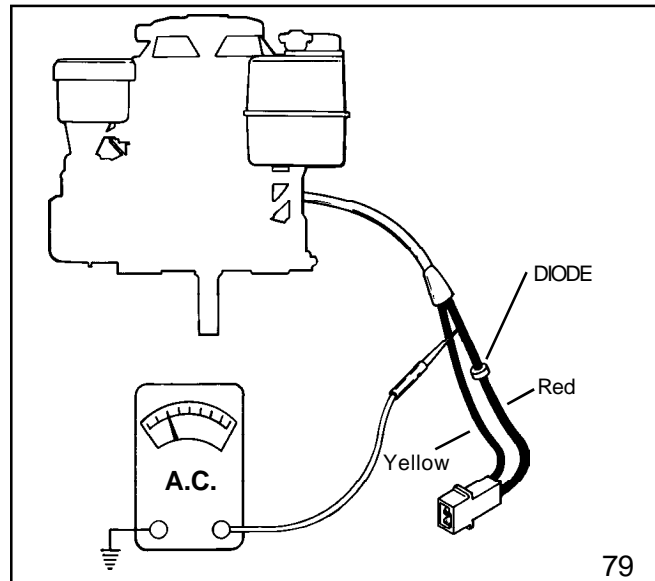
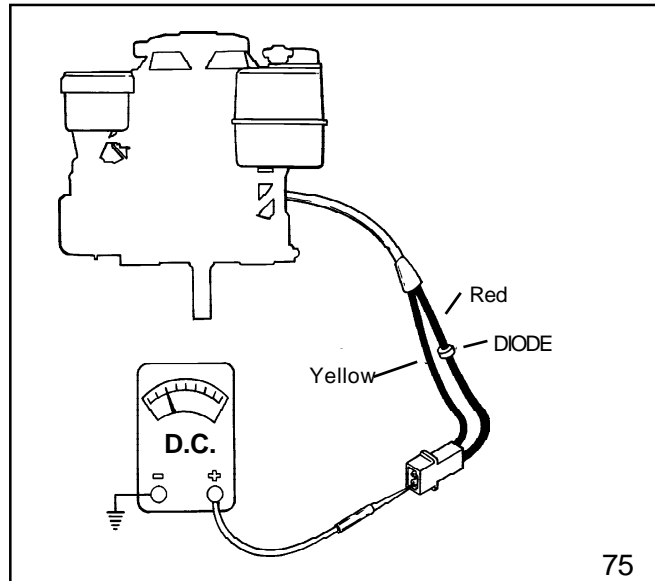

Models OVM/OVXL/OHV

(Read between Engine and Diode, diag. 81 & 82)

With the engine running the minimum values should read:

2500 R.P.M. - 20.0 Volts A.C.

3000 R.P.M. - 25.0 Volts A.C.

3300 R.P.M. - 26.5 Volts A.C.

3600 R.P.M. - 29.0 Volts A.C.

Models OHV13.5-17.0

(Read between Engine and Diode)

2500 R.P.M. - 17.0 Volts A.C.

3000 R.P.M. - 21.0 Volts A.C.

3600 R.P.M. - 24.5 Volts A.C.

If low or no voltage is experienced, replace the alternator. If the alternator puts out the minimum A.C. voltage, replace the diode.

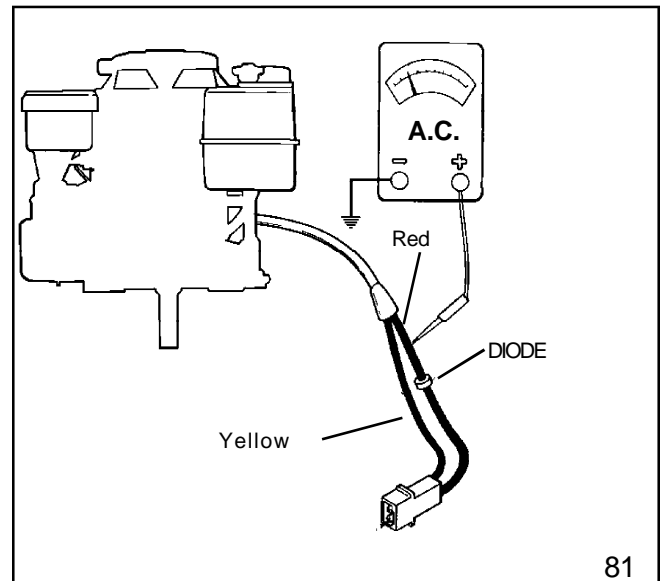

3 Amp D.C. 5 Amp A.C. Alternator Models: H & HSK 50-60, HH50-60, HM & HMSK 70-80-90-100, TVM125-140-170-195-220, TVXL195-220

This unit combines a 3 Amp D.C. system used to charge a battery and a 5 Amp A.C. system used for lighting. Located in the red wire of the harness is a diode which converts the alternating current to direct current for charging the battery. The yellow wire provides the A.C. voltage for the lighting circuit.

CHECKING THE SYSTEM: To check the system, disconnect the plug and measure the D.C. voltage at the red wire terminal (diag. 82). Measure the A.C. voltage at the yellow wire terminal. With the engine running the minimum values should be:

3 Amp D.C.

2500 R.P.M. - 8.0 Volts D.C.

3000 R.P.M. - 11.0 Volts D.C.

3600 R.P.M. - 13.0 Volts D.C.

5 Amp A.C.

2500 R.P.M. - 8.0 Volts A.C.

3000 R.P.M. - 11.0 Volts A.C.

3600 R.P.M. - 13.0 Volts A.C.

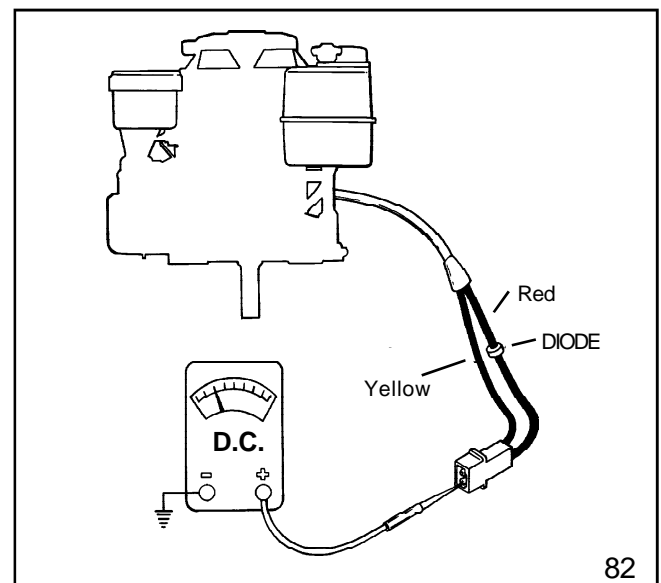

If the above minimum values are noted, system is okay. Check for defective lights, wiring or switches. If less than above values are noted, pull back the protective shrink tubing from the diode. Using an A.C. voltmeter, check the voltage between the alternator and diode as shown (diag.83).

(Continued on Next Page)

All Models

With the engine running the minimum values should read:

2500 R.P.M. - 20.0 Volts A.C.

3000 R.P.M. - 25.0 Volts A.C.

3300 R.P.M. - 26.5 Volts A.C.

3600 R.P.M. - 29.0 Volts A.C.

If low or no voltage is experienced, replace the alternator. If the alternator puts out the minimum A.C. voltage, replace the diode.

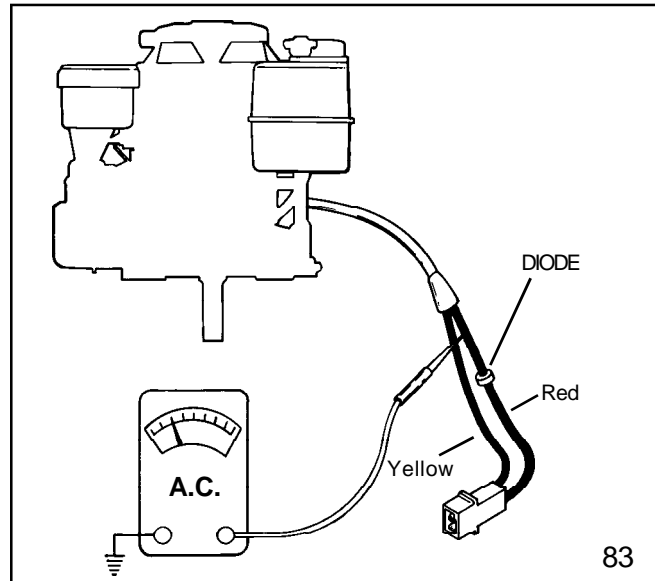

3 Amp A.C. Lighting Alternator Models: H & HSK 30- 35, HS & HSSK 40, H & HSK 50-60, HH50-60, HM & HMSK 70-80-100, HHM80

Before making any exterior tests, check for an inoperative switch, shorted wires and burned out headlight and/or stop tail light. To check out the alternator, check the A.C. lead to ground (diag. 84).

With engine running the minimum values should read:

2500 R.P.M. - 8.0 Volts A.C.

3000 R.P.M. - 9.5 Volts A.C.

3300 R.P.M. - 10.5 Volts A.C.

3600 R.P.M. - 11.5 Volts A.C.

If the above minimum readings are noted, the alternator is okay. Check for defective lights, wiring or switches. If less than the above readings, the alternator is defective.

NOTE: ON OLDER POINT IGNITION SYSTEMS, THE A.C. OUTPUT LEADS ARE BLACK AND RED.

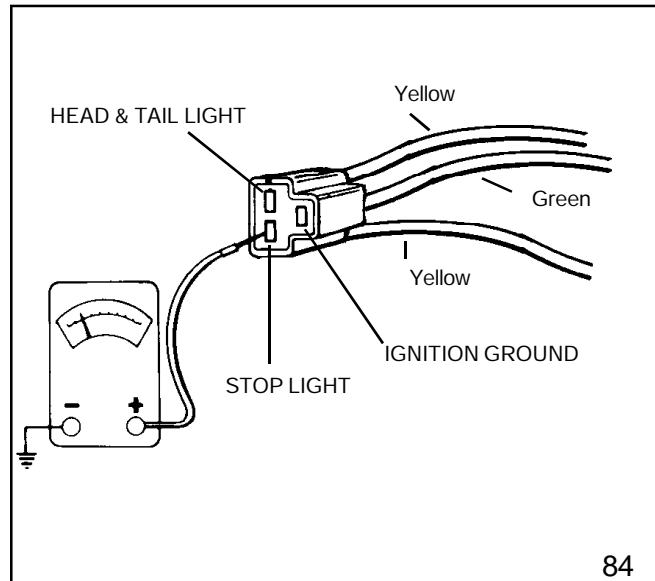

5 Amp Alternator System Regulator-Rectifier Under Blower Housing

CHECKING THE SYSTEM: An open circuit D.C. voltage check cannot be made with this system. If a known good battery fails to maintain a charge, proceed in making an A.C. voltage test.

To do this, the blower housing must be removed, and the regulator-rectifier must be brought outside of the blower housing.

Disconnect the red D.C. output connector at the wiring harness (**not at the regulator/rectifier**) and connect the probes from an A.C. voltmeter to the wire terminals at the regulator-rectifier (diag. 85).



CAUTION: AT NO TIME SHOULD THE ENGINE BE STARTED WITH THE BLOWER HOUSING REMOVED.

With the engine running the minimum values should read:

- 2500 R.P.M. - 19.0 Volts A.C.
- 3000 R.P.M. - 23.0 Volts A.C.
- 3300 R.P.M. - 26.0 Volts A.C.
- 3600 R.P.M. - 28.0 Volts A.C.

If the minimum values are noted; the regulator-rectifier is defective. If less than above readings, the alternator is defective.

7 Amp Alternator System Regulator-Rectifier External to Engine

CHECKING THE SYSTEM: To check the system, disconnect the D.C. or B (+) wire at the switch end and measure D.C. voltage between the lead and ground (diag. 86).

With the engine running the minimum values should read:

- 2500 R.P.M. - 9.0 Volts D.C.
- 3000 R.P.M. - 11.0 Volts D.C.
- 3600 R.P.M. - 14.0 Volts D.C.

If the minimum readings are noted, system is okay.

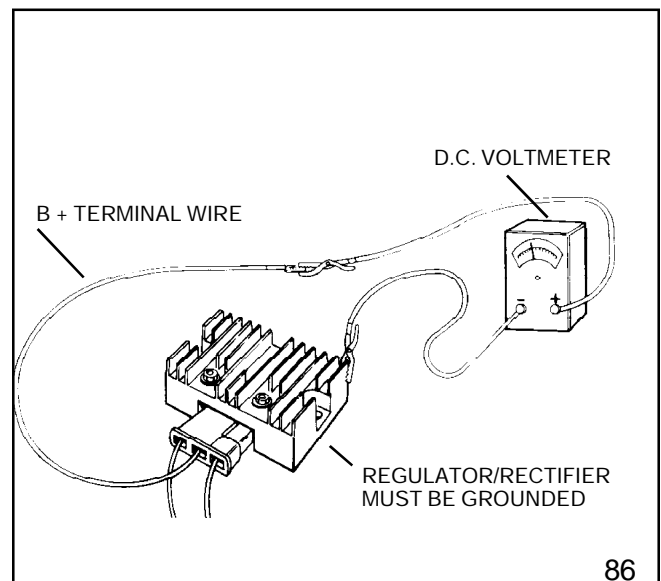
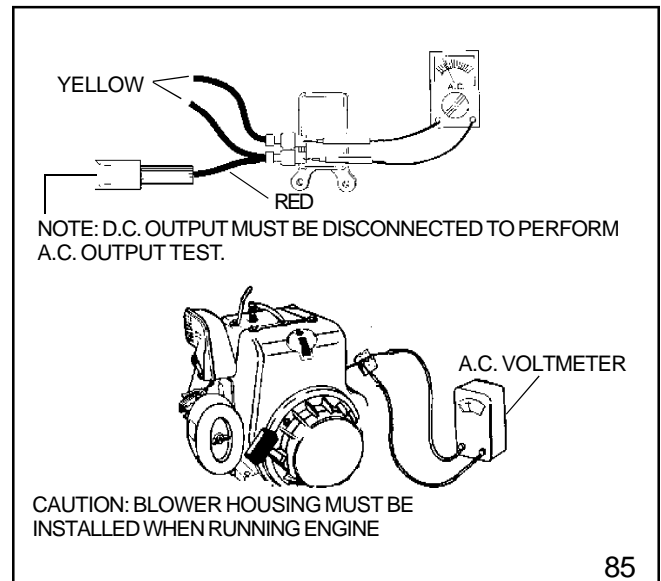

(Continued on Next Page)

Check for a defective ammeter, wiring, etc. If less than the above readings, disconnect the plug from the regulator-rectifier, and insert the A.C. voltmeter probes in the two outside terminals (diag. 87).

With the engine running the minimum values should read:

2500 R.P.M. - 12.0 Volts A.C.

3000 R.P.M. - 14.0 Volts A.C.

3600 R.P.M. - 18.0 Volts A.C.

If the minimum readings are noted, the regulator-rectifier is defective. If less than the above readings, the alternator is defective.

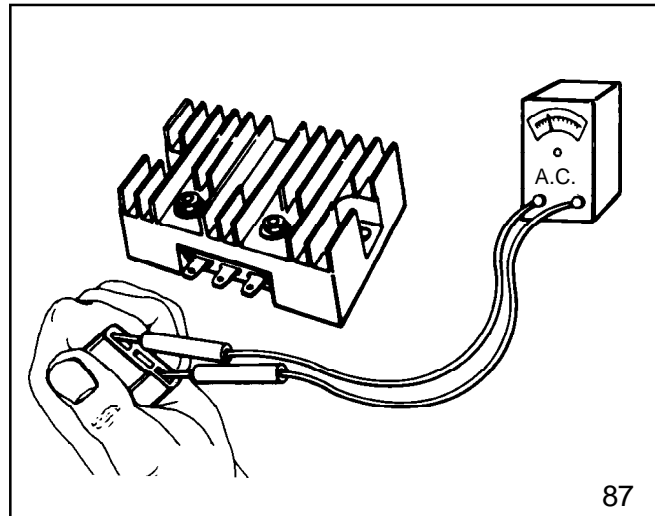

87

7 Amp Alternator System Regulator-Rectifier Under Engine Block Housing, Models: H50-60, HH50-60, HM70-80-100, HHM80, TVM125-140-170-195-220

In this system, the regulator and rectifier are combined in one solid state unit mounted under the blower housing of the engine.

Various types of regulator-rectifiers have been used on different applications. Test procedures for all types are the same. However, regulator styles are not interchangeable (diag. 88).

CHECKING THE SYSTEM: An open circuit D.C. voltage check cannot be made with this system. If a known good battery fails to maintain a charge, proceed in making an A.C. voltage test.

To do this, the blower housing must be removed, and the regulator-rectifier must be brought outside of the blower housing.

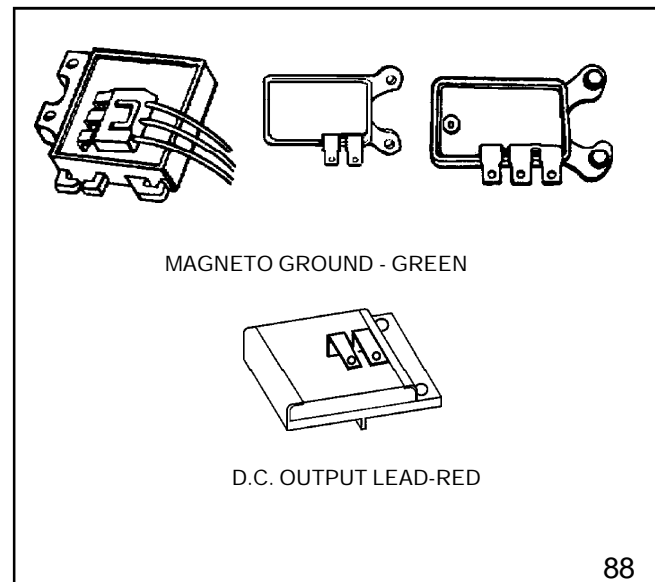

88

Keep the A.C. leads attached to the regulator-rectifier. Install the blower housing with the regulator-rectifier outside the housing. With an A.C. voltmeter probe the regulator as shown (diag. 89).

CAUTION: AT NO TIME SHOULD THE ENGINE BE STARTED WITH THE BLOWER HOUSING REMOVED.

With engine running, minimum A.C. voltage from lead to lead should be:

2500 R.P.M. - 16.0 Volts A.C.

3000 R.P.M. - 19.0 Volts A.C.

3300 R.P.M. - 21.0 Volts A.C.

3600 R.P.M. - 23.0 Volts A.C.

If the minimum readings are noted, the alternator is okay. If the system fails to charge a known good battery, the regulator-rectifier must be defective.

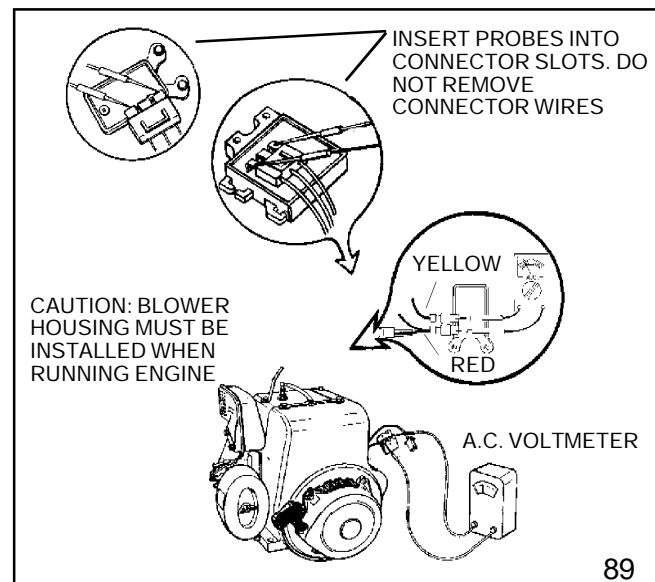

89

10 Amp A.C. Alternator

CHECKING THE SYSTEM: Unplug the connector at the wiring harness supplied by the OEM. Proceed to make an A.C. output check. Place one lead of the A.C. voltmeter into the center of the connector. Place the other lead to engine ground (diag. 90).

With the engine running the minimum values should read:

2500 R.P.M. - 16.0 Volts A.C.

3000 R.P.M. - 20.0 Volts A.C.

3300 R.P.M. - 22.0 Volts A.C.

If less than above output, the alternator assembly is defective.

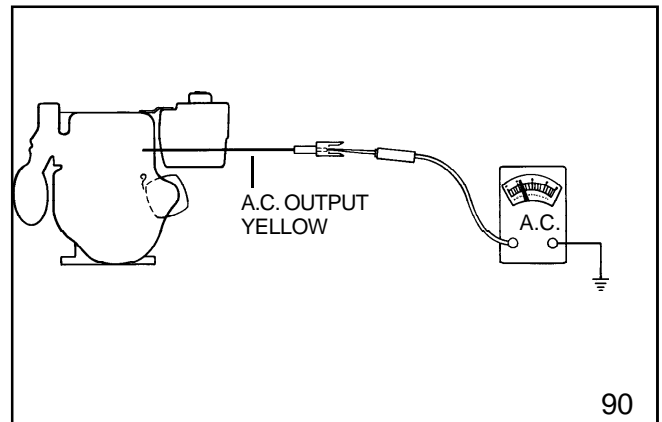

10 Amp Alternator System - Regulator - Rectifier-External to Engine

In this system, the regulator and rectifier are combined in one solid state unit.

CHECKING THE SYSTEM: To check the system, disconnect the D.C. or B (+) wire at the switch end and measure D.C. voltage between the lead and ground (diag. 91).

With the engine running the minimum values should read:

2500 R.P.M. - 13.0 Volts D.C.

3000 R.P.M. - 16.0 Volts D.C.

3600 R.P.M. - 20.0 Volts D.C.

If the minimum values are noted, the system is okay. Check for a defective ammeter, wiring, etc. If less than the above readings, disconnect the plug from the regulator-rectifier, and insert the A.C. voltmeter probes in the two outside terminals (diag. 92).

With the engine running the minimum values should read:

2500 R.P.M. - 16.0 Volts A.C.

3000 R.P.M. - 19.0 Volts A.C.

3600 R.P.M. - 24.0 Volts A.C.

If the minimum readings are noted, the alternator is okay.

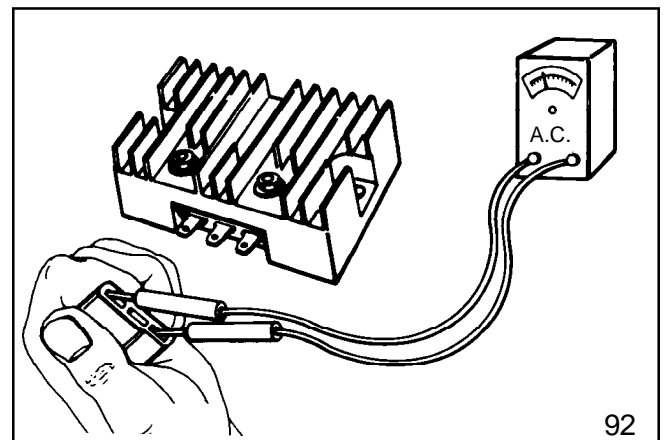
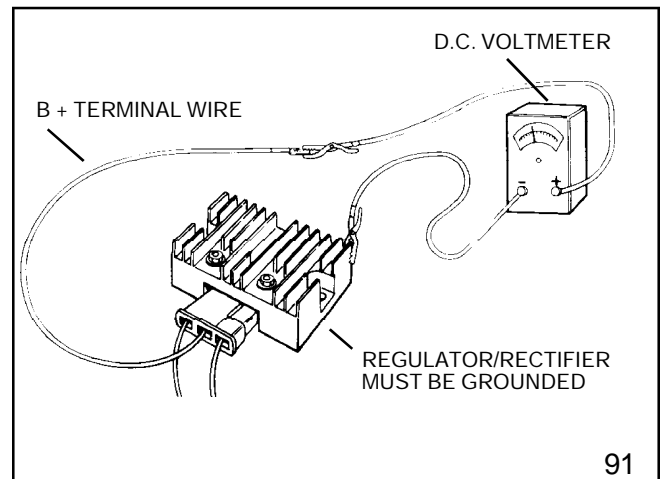

16 Amp Alternator System with External Regulator

CHECKING THE SYSTEM: An open circuit D.C. voltage check cannot be made with this system. If a known good battery fails to maintain a charge, proceed in making an A.C. voltage test.

Disconnect the red D.C. output connector at the wire harness and connect the probes from an A.C. voltmeter to the wire terminals at the regulator-rectifier (diag. 93).

With the engine running the minimum values should read:

2500 R.P.M. - 21 Volts A.C.

3000 R.P.M. - 26.5 Volts A.C.

3600 R.P.M. - 31.0 Volts A.C.

If the minimum values are noted, the alternator is operating properly. If less than the above values are noted, the alternator is defective.

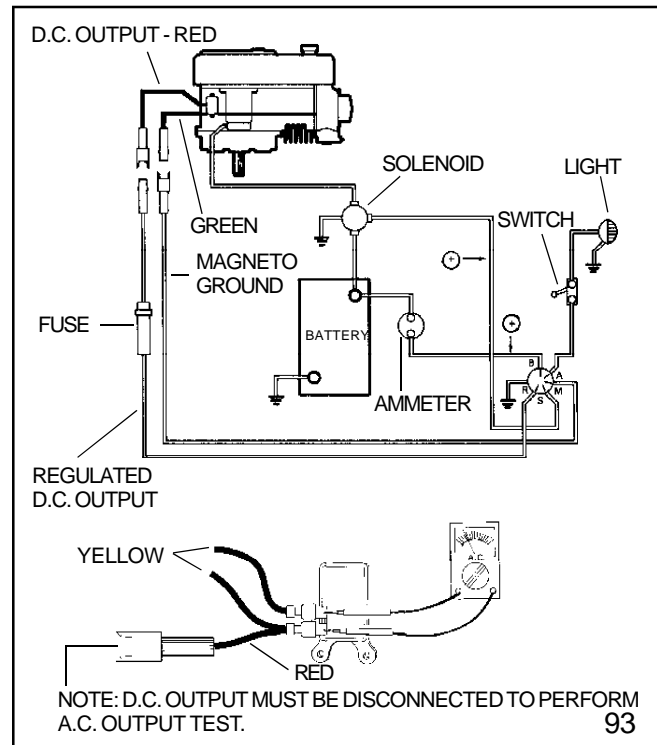

20 Amp Alternator System

In this system, the regulator and rectifier are combined in one solid state unit which is mounted into the blower housing of the engine.

CHECKING THE SYSTEM: An open circuit D.C. voltage check cannot be made. If a known good battery fails to maintain a charge, proceed to make an A.C. voltage test.

Disconnect the plug leading to the regulator rectifier, and insert the A.C. voltmeter probes into the two outside terminals.

With the engine running the minimum values should read:

2500 R.P.M. - 32.0 Volts A.C.

3000 R.P.M. - 38.0 Volts A.C.

3600 R.P.M. - 45.0 Volts A.C.

If the minimum readings are noted, alternator is okay. If the system fails to charge a known good battery, regulator-rectifier must be defective.

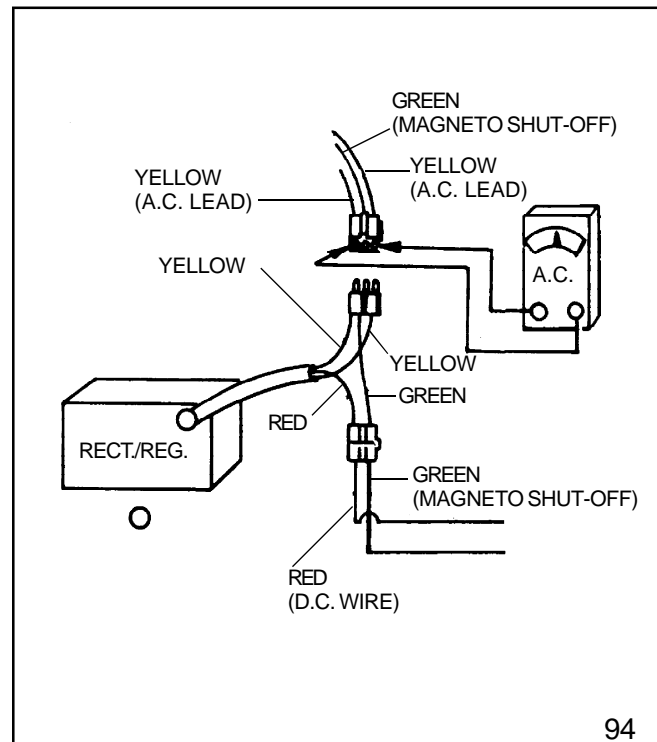

Typical Wiring Circuits

3 Amp D.C. / 5 Amp A.C. Alternator

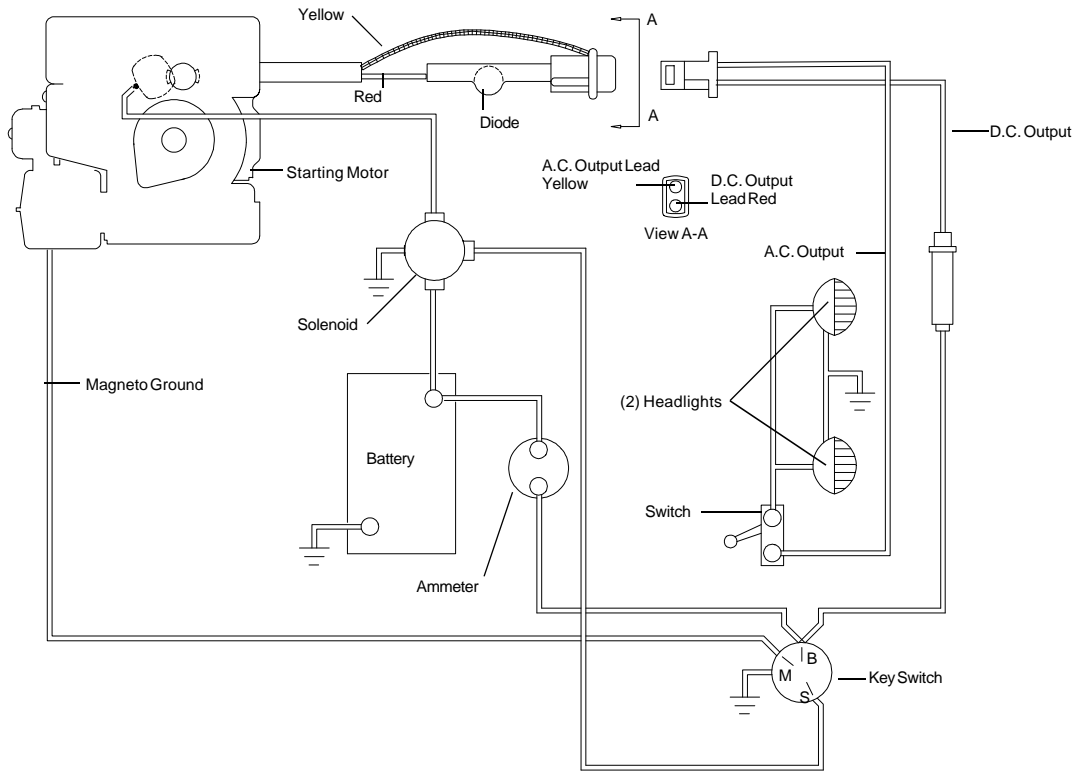

3 Amp Alternator (D.C.)

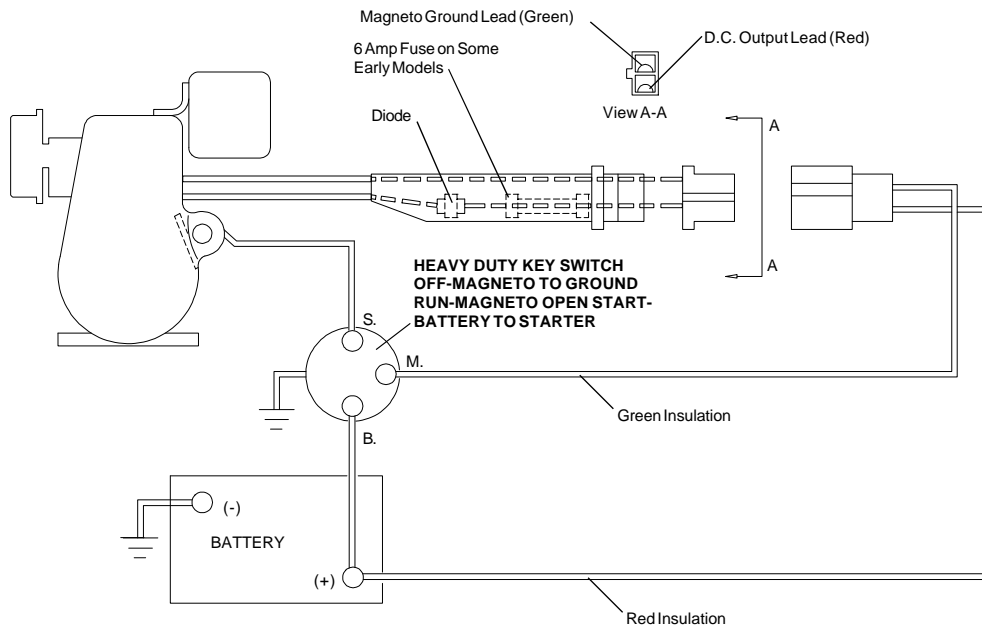

Typical Wiring Circuits - *continued*

5 Amp Alternator System

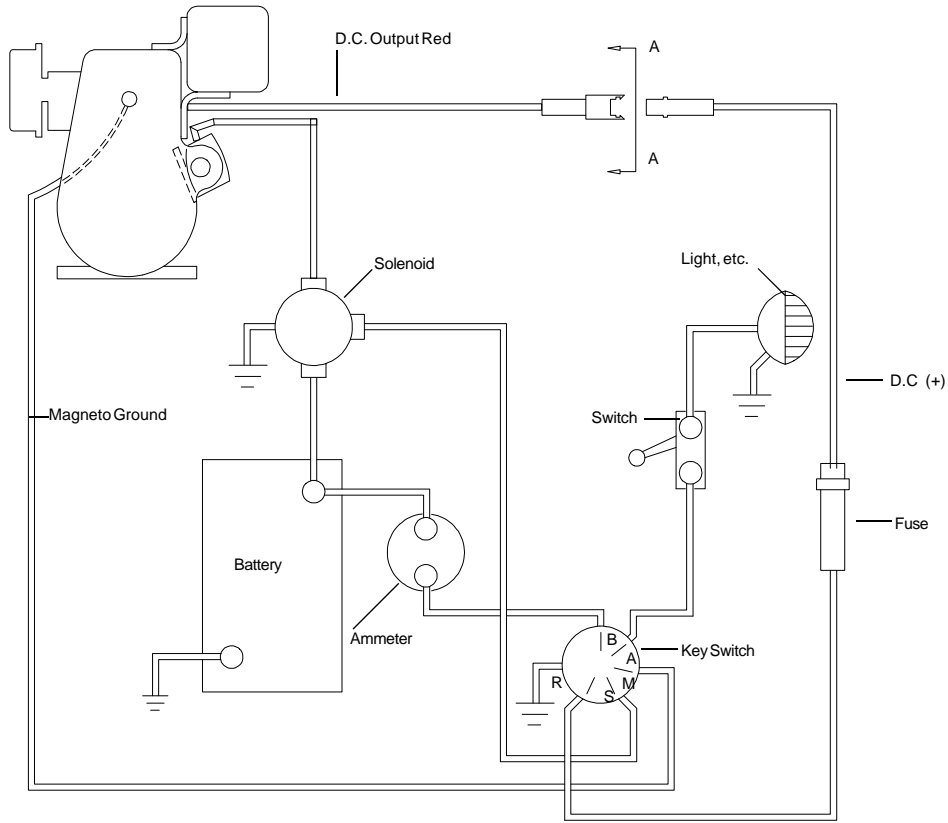

7 AMP ALTERNATOR SYSTEMS EXTERNAL REGULATOR-RECTIFIER

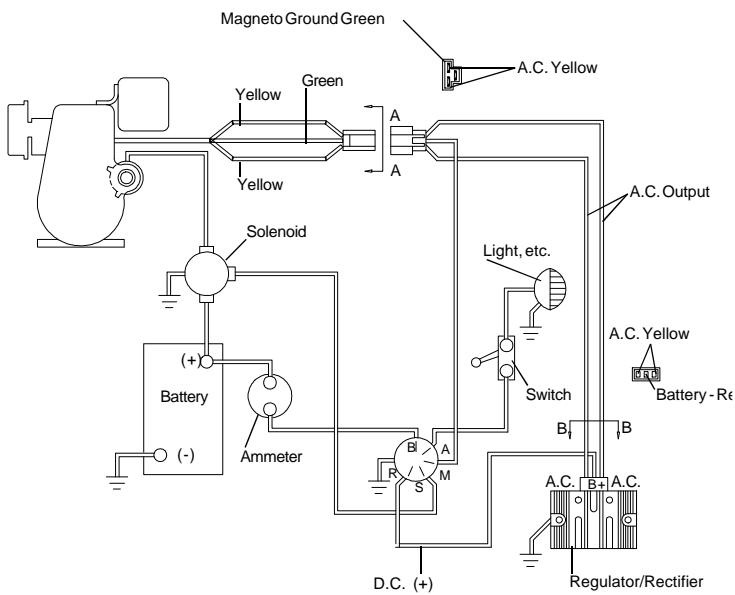

7 AMP & 12 AMP D.C. REGULATED ALTERNATOR

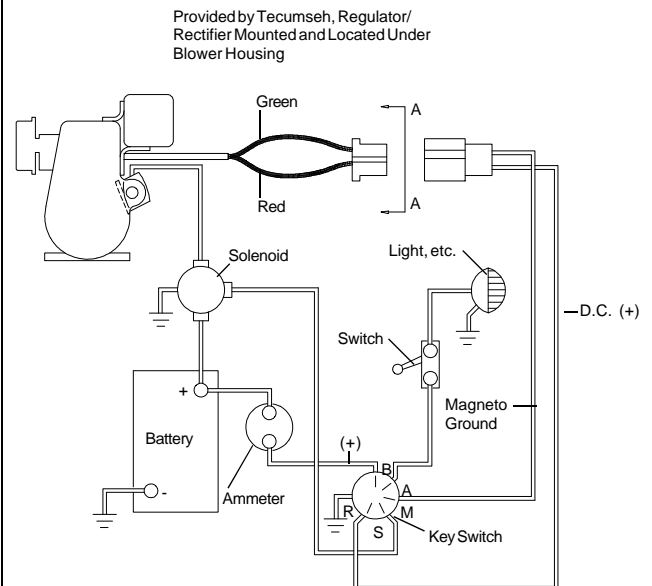

Typical Wiring Circuits - *continued*

20 AMP ALTERNATOR SYSTEMS

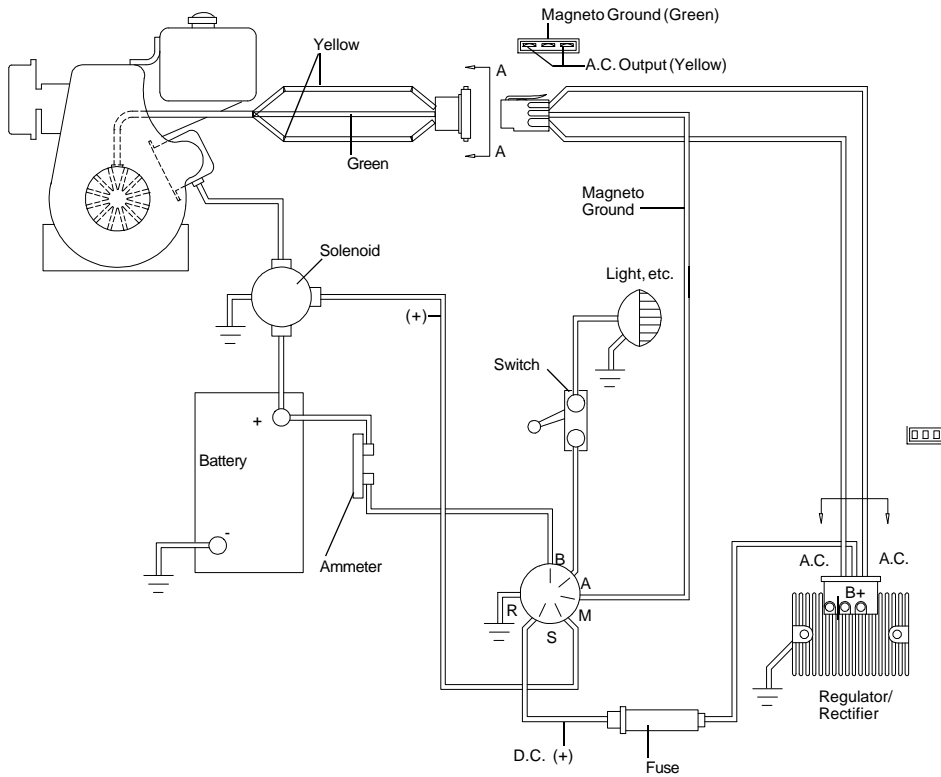

Provided by Tecumseh,
Regulator/Rectifier Mounted
and Located Under Blower
Housing

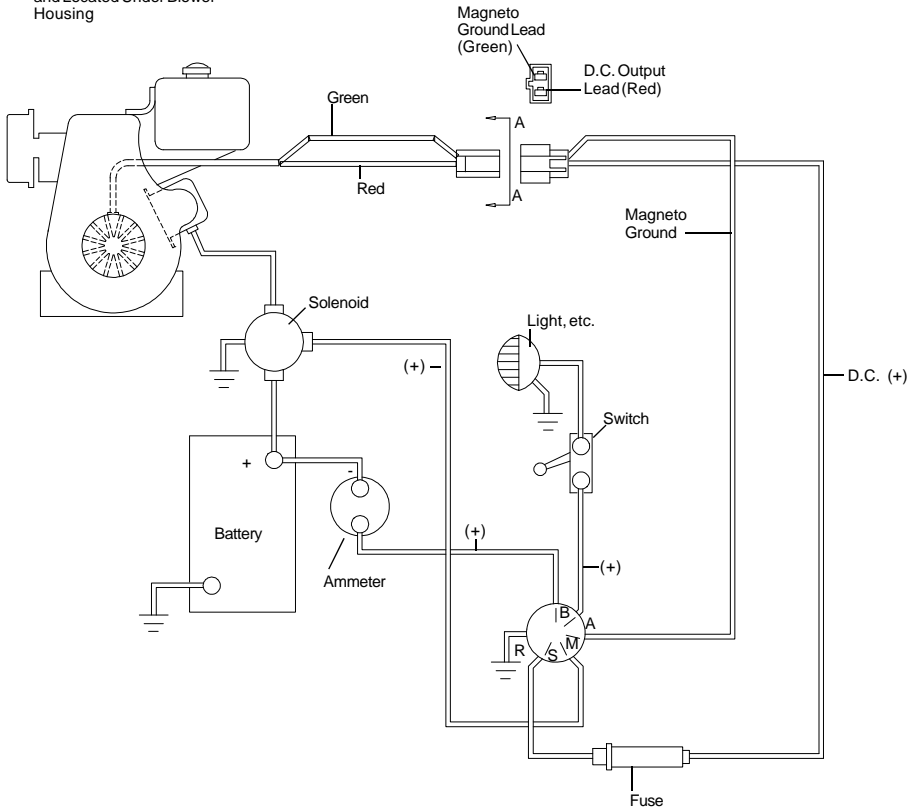

Peerless Identification

RIGHT ANGLE DRIVES

100 SERIES
A or B

1200 SERIES
A or B

1100 SERIES
A

600 SERIES
A or B

700 SERIES
A

2600 SERIES
A

2800 SERIES
A

810 SERIES
801 SERIES
A

900 SERIES
920 SERIES
930 SERIES
A

915-000
A

910 SERIES
A

915 SERIES
A

2400 SERIES
A

820 SERIES
A

1300 SERIES
A

2300 SERIES
A or B

2500 SERIES
A

MST and VST

SAMPLE (OLD STYLE)

○ MOD 506 ○
PEERLESS
1 275 1374

Individual Serial Number
Manufactured on the 275th Day
Manufactured in 1991

SAMPLE (NEW STYLE)

MST205- □□□ — Specification Number
||||| — Manufacturers
SERIAL 6 0 0 2 — Requested Features

Serial Number Julian Date (The Second Day of 1996)

Identification Number Locations

Early Models were not identified with a model number on the unit.
THE MODEL NUMBER WILL BE FOUND ON: A. Metal tag or decal attached to unit as illustrated.
 B. Stamped on unit as illustrated.

Peerless Identification - continued

The recent warranty audit referenced in bulletin number "123" suggested we review the way our new Tecumseh/Peerless® models are identified. The review found improvements were needed in the identification system to make them standard with the new emission regulation's requirements covering engine product and the "New ESA 157 Claim Form".

As a result, we have changed the product ID tag to make it easier to read. Should this data be needed for service or warranty situations these improvements will make locating the needed model and specification information easier.

Example Numbers 1 and 2 below, show the present bar code labels currently being used. We have identified the important fields of information that is required for warranty claims.

In addition, a new easier to read bar code label (No. 3 below) is being introduced on all units provided after October 1, 1998. Again we have highlighted the information you are required to supply.

This information is critical for prompt warranty reimbursement to your shop, please pay close attention to this number.

MODEL NUMBER REQUIRED FOR WARRANTY SPECIFICATION NUMBER REQUIRED FOR WARRANTY

PEERLESS 205 - 027C TECUMSEH

MODEL DATE SERIAL



205 - 027C8194A0048

① D.O.M. (DATE OF MANUFACTURE)
ORIGINALLY SERIAL NUMBER

MODEL NUMBER REQUIRED FOR WARRANTY SPECIFICATION NUMBER REQUIRED FOR WARRANTY

PEERLESS MST - 206 - 502A TECUMSEH

DATE MFG. SERIAL NO.



6304A00013

② D.O.M. (DATE OF MANUFACTURE)
ORIGINALLY SERIAL NUMBER

MODEL NUMBER REQUIRED FOR WARRANTY SPECIFICATION NUMBER REQUIRED FOR WARRANTY

PEERLESS VST - 205 - 020C TECUMSEH

MODEL SPEC



D.O.M.
7070A - 0005

③ D.O.M. (DATE OF MANUFACTURE)
ORIGINALLY SERIAL NUMBER
"NEW TYPE"

Transaxle Troubleshooting

In-Line Shift Models (i.e. 800, 820, 915, 920, 930 MST)

Transaxle troubleshooting can be a mystery to many technicians, but by using a common sense approach that most technicians use for engine troubleshooting, the mystery will disappear and be replaced with confidence, skill and eventually, mastery of transaxle service.

Before you begin to take off the wheels (the hardest part of transaxle repair) check the associated equipment.

- A. Check belts for proper adjustment.
- B. Check for proper adjustment of brake, clutch, shifter and related linkages, etc.
- C. Check pulleys for sheared keys and proper belt disengagement.
- D. Check for proper shifting by removing drive belt. If transaxle does not shift freely it would indicate an internal transaxle problem.

After you have made all preliminary checks it may now become necessary to remove the transaxle from the equipment.

The first area to check after removing the transaxle cover is the shifting keys. The keys are the safety link to protect against serious gear damage. Check keys for breaks, cracks, stress marks, worn shift key ends and proper spring tension (diag. 95).

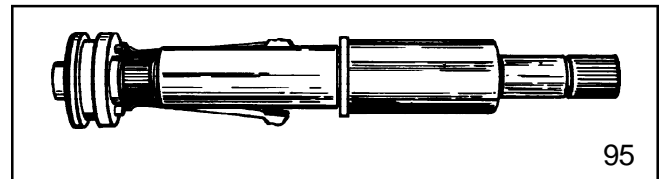

Check input bevel gears for excessive wear. If gears are damaged, the cover should be checked for distortion (diag. 96).

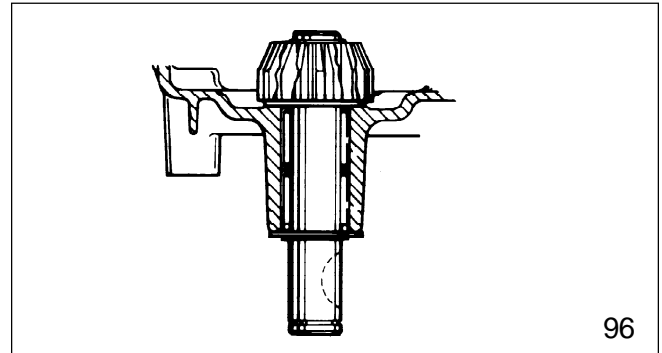

To properly troubleshoot and inspect the transaxle further, it is necessary to clean grease from parts during disassembly.

During disassembly check shifting gears and washers for proper assembly.

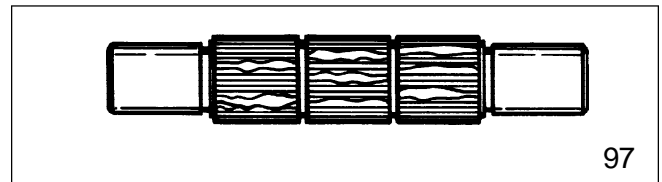

Check countershaft splines and splines on inner diameter of countershaft gears (diag. 97).

Check reverse sprockets for damaged teeth and if applicable, inner diameter spline area. Check chain for damage or excessive stretching.

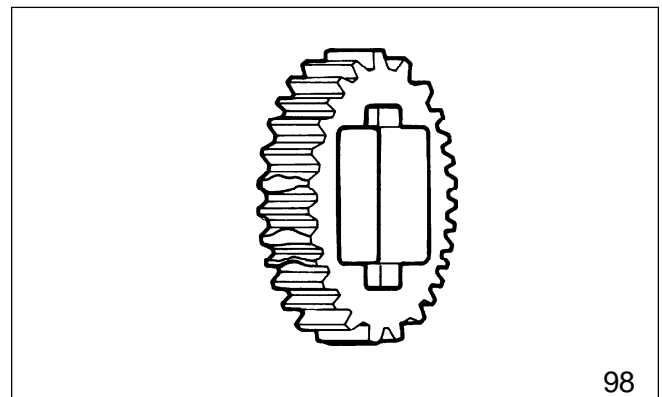

Check differential ring gear and bevel gears for excessive wear. Bevel gears should be replaced as a set if any gear is damaged. When replacing snap rings, put flat side of snap ring against the thrust side of gear. Do not over stretch the snap rings when removing and installing (diag. 98).

Check axles and as applicable, axle bearings or transaxle case/cover for wear or damage.

Hard Shifting Transaxles and Drive Belts

Often hard shifting is blamed on an internal problem in the transaxle.

To determine if the problem is transaxle or equipment related make these simple checks.

1. Turn the unit off so that all power is removed to the transaxle
2. With the unit off move the shift lever through the shift gate. Movement of the lever should have only slight resistance. The shifting effort should be equal when the engine is off and when running. If the unit is difficult to shift the problem would be internal and the transaxle would need to be removed and repaired
3. If the unit shifts with ease, check the following areas that would be equipment related. Check to see if the belt is releasing from the pulley on the engine and transmission/transaxle, it may require that the belt guides be repositioned. The distance required from the pulley to the guide is typically 1/16" to 3/16" (1.6 mm - 4.8 mm), always check the O.E.M. specs.
4. Check to see if the pulley is damaged and may not be releasing the belt.
5. Make sure that the belt is the correct belt in case the customer has replaced it with a non original, possibly more aggressive belt.
6. Check the brake/clutch pedal to make sure that when the pedal is depressed that the idler pulley is releasing the belt tension before it applies the brake. If this does not happen the unit will still be under a load and be impossible to shift
7. The final area to check would be for damaged or binding shift linkage.

Hard shifting with the engine off could be caused by:

1. Shift linkage out of adjustment.
2. Corrosion in the transaxle or transmission.
3. Damaged shift keys, gears, or shifter brake shaft.
4. Belt guides missing or improperly adjusted (see equipment manufacturer specs.)

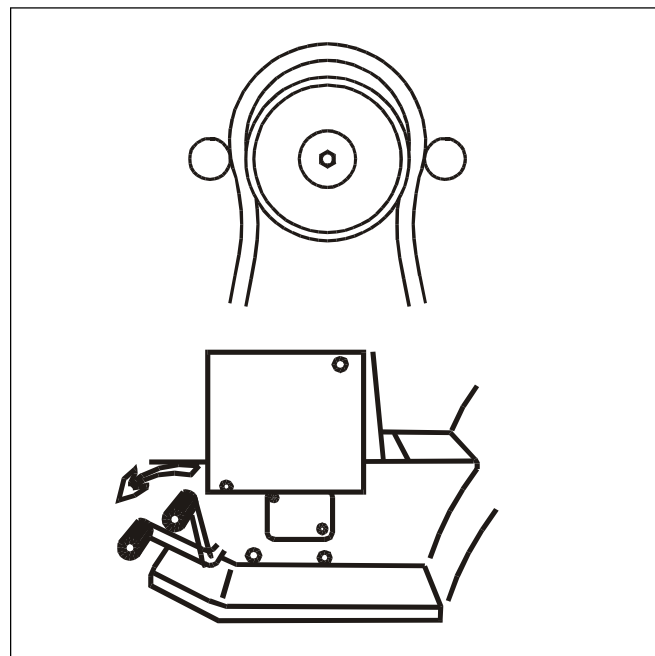
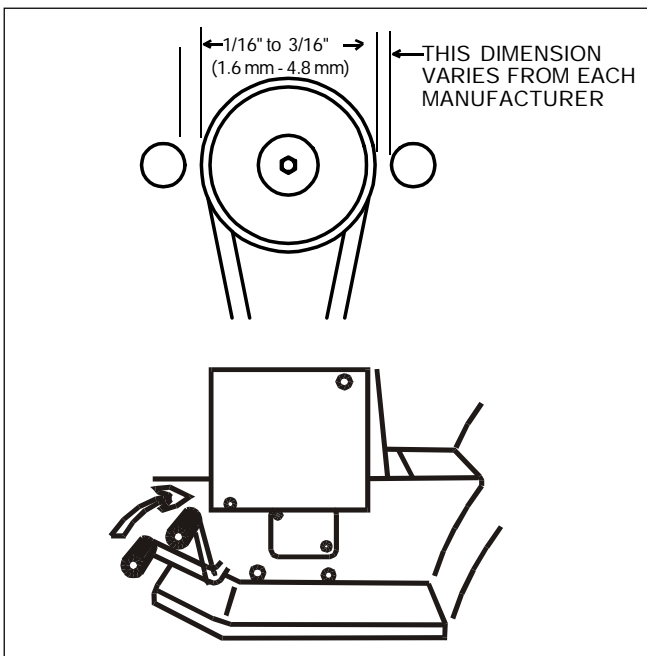

For proper declutching to occur, it is very important that the engine belt guide be set at a predetermined gap (set by the manufacturer) and away from the belt with the belt engaged.

With clutch disengaged, it is very important that the belt blossoms away from the engine pulley. Belt must stop turning before transaxle shifting can occur.

VST Troubleshooting

The information on this page has been provided to help understand the internal operation of the VST. Do not use this information to attempt any internal repairs. Tecumseh's current policy on hydrostatic transaxles that have internal failures is to replace the complete unit. This has not changed. However, Tecumseh would like to provide a failure checklist to assist in making an accurate evaluation of the complete tractor to eliminate any unnecessary replacements. Here is a list of items to check and corrective actions to take.

To properly test the unit for power loss.

1. Allow the unit to cool before trying the following steps.
2. Put the shift lever in a position that is 1/2 of the travel distance from neutral to forward.
3. Place the tractor on a 17 degree grade.
4. Drive the tractor up the grade (without the mower deck engaged). The loss of power experienced should be approximately 20%. This is considered normal. If the loss of power is approximately 50%, this would be considered excessive.
5. Bring the unit to neutral, shift into forward and note the response. Care should be taken to move the lever slowly to avoid an abrupt wheel lift.

To determine if the problem is with the hydro unit, all external problem possibilities must be eliminated. Here are some potential problem areas.

1. **Overheating:** Heat can cause a breakdown in the viscosity of the oil which reduces the pressure used to move the motor. Remove any grass, debris, or dirt buildup on the transaxle cover and / or between the cooling fins and fan. Buildup of material will reduce the cooling efficiency.
2. **Belt slippage:** A belt that is worn, stretched, or the wrong belt (too large or wide) can cause belt slippage. This condition may have the same loss of power symptom as overheating. Typically, the unit which has a slipping belt will exhibit a pulsating type motion of the mower. This can be verified visually by watching the belt and pulley relationship. If the belt is slipping, the belt will chatter or jump on the pulley. If the belt is good, a smooth rotation will be seen. Replace the belt and inspect the pulley for damage.
3. **Leakage:** The VST and 1800 Series have two oil reservoirs which can be checked for diagnostic purposes. The first is the pump and motor expansion bellows, with a small diameter blunt or round nose probe, check the bellows depth through the center vent hole. Proper depth from the edge of that hole is 3-1/4 - 3-1/2 inches (8.25 - 8.9 cm).

The second chamber is for the output gears including the differential. FIRST make sure the tractor is level, then remove the drain/fill plug. NOTE: Some units that do not have differential disconnect will have two plugs. We recommend using only the primary plug. With a small pocket rule insert until you touch bottom of case. You can then remove it and check for 1/4 - 3/8 inches (6.5 - 9.5 mm) contact, this is full at its 8 oz. capacity.

4. **Low ground speed:** If the linkage is not synchronized to absolute neutral, or the shift lever is not properly fastened to the tapered control shaft, full forward travel may not be achieved. This may cause a false reading and be misdiagnosed as a low power condition. This also could be caused by the brake not releasing.

To determine absolute neutral, the hole in the tapered control shaft must face straight up and down, at this point make sure the OEM linkage is in neutral. To properly fasten the control lever to the shaft, torque the nut to 25-35 ft. lbs. (34 - 48.3 Nm) of torque with the shaft and the lever in neutral.

When attaching the shifter arm to the shaft you must prevent any rotation during torquing. This can be done by placing a long 5/16 bolt in the hole of the shaft. Hold the bolt until the tapers are locked and the nut torque is correct.

To make sure that the brake is not binding, drive the unit up a slight grade.. Position the speed control lever into neutral. The unit should coast backwards. If the unit does not coast back slowly, the brake is not released from the brake disk. Adjust the brake linkage to release the brake completely when the foot pedal is released.

5. **Hard to shift:** Typically hard to shift symptoms are not caused by the hydrostatic unit. The shift arm should move with relative ease. Approximately 40-50 inch lbs. (4.48 - 5.6 Nm) at the transaxle for foot pedal units or 150-200 inch lbs. (16.8 -22.4 Nm) for hand operated units. This varies depending on the type of linkage. Binding may occur in the linkage connections due to rust or moisture. Lubricating these connections and checking for bent or damaged parts should resolve hard shifting.

Peerless Torque Chart

TORQUE VALUE				
PART	MODELS AFFECTED	IN-LBS	FT-LBS	Nm
Bolt 5/16-18 (Housing)	100 Series	228-264	19-22	25.8 - 29.9
Nut 5/16-18 (Drive Gear)	100 Series	120-156	10-13	13.6 - 17.7
Bolt 1/4-20 (Case to Cover)	600 Series	84-108	7-9	9.5 - 12.2
Bolt 5/16-18 (Axle Support Housing)	600 Series	156-180	13-15	17.7 - 20.4
Bolt 1/4-20 (Shift Lever Housing)	600 Series	84-108	7-9	9.5 - 12.2
Bolt 1/4-20 (Brake-Disc)	600 Series	84-108	7-9	9.5 - 12.2
Bolt 1/4-20 (Case to Cover)	800 & 900 Series (Except 820)	90-100	7.5-8.3	10.2 - 11.3
Bolt 1/4-20 (Brake-Disc)	800, 900 & MST Series	85-110	7.1-9.2	9.7 - 12.5
Bolt 5/16-18 (Case to Cover)	820 Series	180-216	15-18	20.4 - 24.5
Bolt 1/4-20 (Bearing Cap)	820 Series	90-100	7.5-8.3	10.2 - 11.3
Bolt 1/4-20 (Differential)	820 Series	84-120	7-10	9.5 - 13.6
Bolt 1/4-20 (Brake Disc)	820 Series	85-110	7.1-9.2	9.7 - 12.5
Bolt 5/16 x 18	1100 Series	180-216	15-18	20.4 - 24.5
Bolt 5/16 x 18	2800 Series	180-216	15-18	20.4 - 24.5
Bolt 1/4-20 (Case to Cover)	1200 Series	96-120	8-10	10.9 - 13.6
Bolt 1/4-20 (Shift Lever Housing)	1200 Series	84-108	7-9	9.5 - 12.2
Bolt 1/4-20 (Differential)	1200 Series	84-120	7-10	9.5 - 13.6
Bolt 1/4-20 (Case to Cover)	1300 Series	90-110	7.5-9.2	10.2 - 12.5
Bolt 1/4-20 (Differential)	1300 Series	84-120	7-10	9.5 - 13.6
Bolt 1/4-20 (Case to Cover)	1400 Series	96-120	8-10	10.9 - 13.6
Bolt 1/4-20 (Shift Lever Housing)	1400 Series	84-108	7-9	9.5 - 12.2
Bolt 1/4-20 (Differential)	1400 Series	84-120	7-10	9.5 - 13.6
Bolt 1/4-20 (Case to Cover)	2300 Series	96-120	8-10	10.9 - 13.6
Bolt 1/4-20 (Shift Lever Housing)	2300 Series	96-120	8-10	10.9 - 13.6
Bolt 5/16-18 (Axle Support Housing)	2300 Series	180-216	15-18	20.4 - 24.5
Bolt 1/4-20 (Differential)	2300 Series	84-120	7-10	9.5 - 13.6
Bolt 3/8-16 (Axle Support Housing)	2300 Series	240-312	20-26	27.2 - 35.4
Bolt 1/4-20 (Case to Cover)	2400 Series	96-120	8-10	10.9 - 13.6
Bolt 1/4-20 (Axle Support Housing)	2400 Series	96-120	8-10	10.9 - 13.6
Bolt 1/4-20 (Differential)	2400 Series	84-120	7-10	9.5 - 13.6
Bolt 5-16/18 (Case to Cover)	2500 Series	180-216	15-18	20.4 - 24.5
Bolt 3/8-16 (Differential)	2500 & 2600 Series	420-480	35-40	47.6 - 54.4
Bolt 1/2-13 (Axle Support Housing)	2500 & 2600 Series	720-780	60-65	81.6 - 88.4
Screws No. 10-24 (Cover)	R.A.D.	20-24	1.6-2	2.2 - 2.7
Bolts 1/4-20 (Retainer Cap)	R.A.D.	90-110	7.5-9.2	10.2 - 12.5

NOTE: On all units containing two jam nuts securing brake lever, hold bottom nut and torque top nut to 100 in. lbs.

Differential Bolts	7 ft. lbs. - 9.5 Nm
"T" Drive Bolt	8-11 ft. lbs. - 10.9 - 15.0 Nm
"T" Drive Cover Screw	20-24 in. lbs. - 2.24 - 3.7 Nm

Lubrication Requirement

PEERLESS LUBE CHART

TRANSAXLES		TRANSMISSIONS		RIGHT ANGLE AND T DRIVES	
Model No.	Quantity	Model No.	Quantity	Model No.	Quantity
600	24 oz./710 ml Oil	2600	†	All Models	4 oz./118 ml Grease
800	30 oz./887 ml Grease	700	12 oz./355 ml Grease	Except *	
801	36 oz./1065 ml Grease	700H	12 oz./355 ml Grease	*1408-P91	3 oz./89 ml Grease
820	36 oz./1065 ml Grease	2800	†	*1409-P91	
900	26 oz./769 ml Grease			*1410-P91	
910	18 oz./532 ml Grease			*3002	
915	10 oz./296 ml Grease			*3003	
920	30 oz./887 ml Grease			*3028	
930	30 oz./887 ml Grease			*3029	
1200	48 oz./1420 ml Oil ††			*3035	
1301	32 oz./946 ml Oil			1000 Series	6 oz. / 180 ml Oil †††
1305				1100	16 oz./473 ml Oil
1309					
1313					
1302	44 oz./1301 ml Oil			DIFFERENTIALS	
1303				All Models	3 oz./89 ml Grease
1304				TWO SPEED AXLE	
1306				All Models	2 oz./59 ml Grease
1307				THREE SPEED AXLE	
1308				All Models	2 oz./59 ml Grease
1310					
1311					
1312					
1314					
1315					
1316					
1317					
1318					
1320					
1321					
1322					
1325					
1328					
1329					
1319					
1323	24 oz./710 ml Oil				
1326					
1327					
LTH	8 oz./240 ml Oil				
MST200 VST205 and 1800's	16 oz./473 ml Oil ††††				
2300	64 oz./1892 ml Oil				
2400	32 oz./946 ml Oil				
2500	†				

NOTICE

Grease: Bentonite Grease
Part Number 788067B

Oil: SAE E.P. 80W90 Oil
Part Number 730229A

† Refer to O.E.M. Mechanic's Manual for type of lubricant

†† To be filled through shift lever opening

††† Some 1000 Right Angle and T-Drives use Bentonite Grease.

†††† Tecumseh's current policy on hydrostatic transaxles with internal failure, is to replace the complete unit. VST and 1800's have two separate reservoirs which can be checked for diagnostic purpose only. The output gear reservoir can be checked with a small pocket rule as outlined in the Motion Drive Systems Book.

Refer to Motion Drive Systems Book, 691218.

TECUMSEH 4-CYCLE LUBRICATION REQUIREMENTS

We often get questions from both customers and dealers regarding the type and brand of oil we recommend.

Tecumseh recommends the use of a high quality, brand name petroleum based oil in our engines. Very few air cooled engines have any type of oil filtration system, making regular oil changes critical to remove impurities from the engine and maximize engine life. **Consult the operators or repair manual for the oil change interval and viscosity base on equipment operating temperature.**

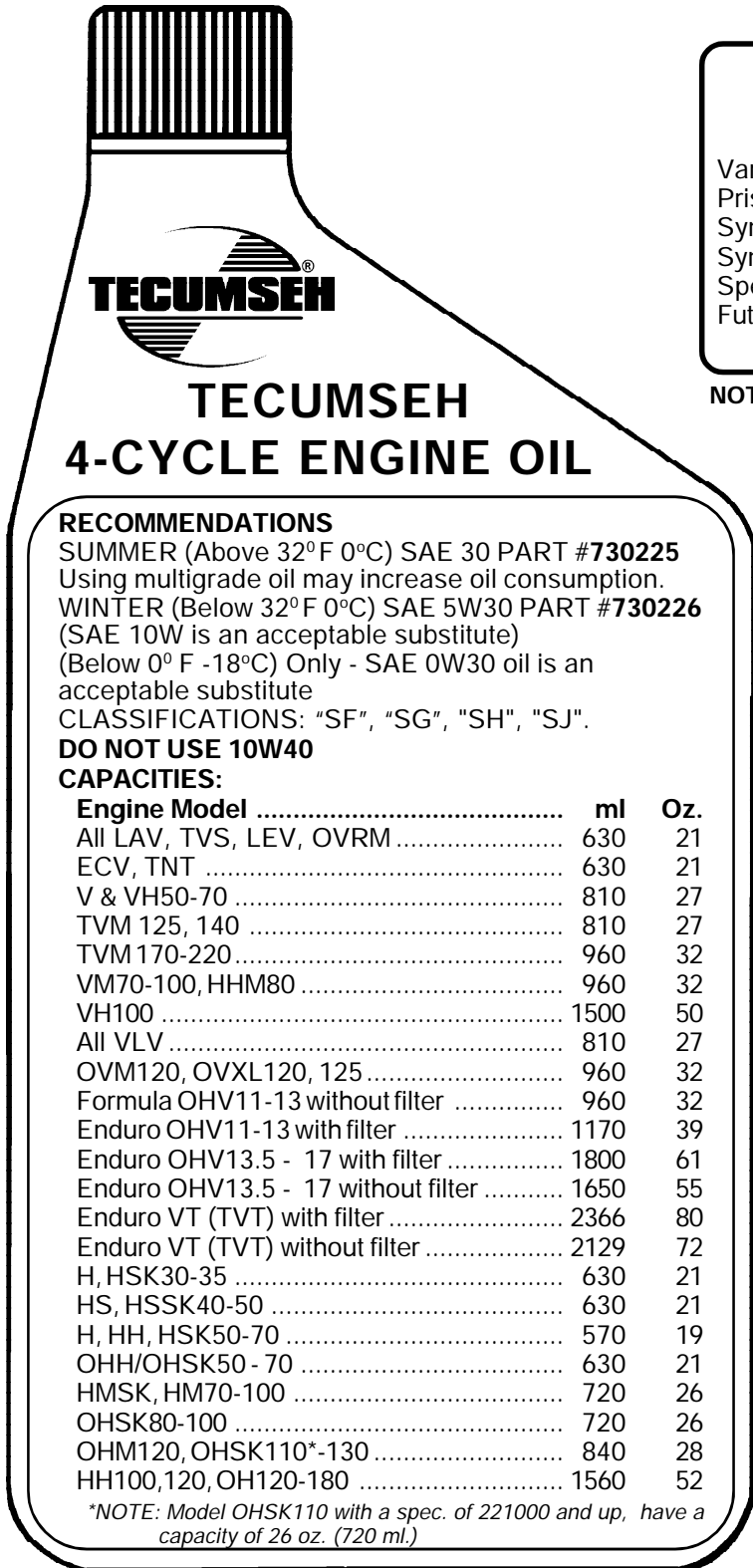

EUROPA MODELS *					
VERTICALS			VERTICALS (CONT.)		
	oz.	ml		oz.	ml
Vantage	21	630	Centura	21	630
Prisma	21	630	HTL	21	630
Synergy	21	630	BVS	21	630
Synergy "55"	27	810	HORIZONTALS		
Spectra	21	630	BH Series	21	630
Futura	21	630	Geotec	21	630
			Series 35 - 50		

NOTE: Vertical shaft engines with auxiliary PTO:
 26 oz. / 700 ml

TECUMSEH 2-CYCLE ENGINE OIL REQUIREMENTS

The proper type and ratio of two cycle oil is critical to long life and low maintenance of the engine. The use of non certified oils and improper mix ratio's can cause severe engine damage and possibly void warranty consideration.

The following is a list of 2 cycle engine oil classifications which are certified for use in Tecumseh 2 cycle engines:

- National Marine Manufacturers Association, (NMMA), TC-WII or TC-W3
- American Petroleum Institute, (API), TC
- Japanese Automobile Standard Organization, (JASO), FB or FC



TWO-CYCLE FUEL/OIL MIX RATIOS		
24:1	32:1	50:1
AV520 Types 670 & 653 AV600 Type 600-10 & Up TC-TCH 200/300 MV100S	TVS600 All Types AH600	TVS / TVXL HSK840 - 850 HSK600 - 635

SEARS CRAFTSMAN TWO CYCLE OIL HAS BEEN TESTED AND APPROVED. ALL MODELS USE A 40:1 MIX RATIO ON ALL 2-CYCLE ENGINES EXCEPT TC'S WHICH USE A 24:1

MIXES EASY
DOES NOT SEPARATE

PREMIUM BLEND FOR BOTH AIR AND WATER COOLED ENGINES ENSURES CYLINDER WALL LUBRICATION

	ENGINE FUEL MIX			
	U.S. Gasoline	U.S. Amount of Oil To Be Added	METRIC Petrol	METRIC Amount of Oil To Be Added
24:1	1 Gallon	5.3 oz.	4 Liters	167 ml
	2 Gallons	10.7 oz.	8 Liters	333 ml
32:1	1 Gallon	4 oz.	4 Liters	125 ml
	2 Gallons	8 oz.	8 Liters	250 ml
50:1	1 Gallon	2.5 oz.	4 Liters	80 ml
	2 Gallons	5.0 oz.	8 Liters	160 ml



Spark Plug Replacement

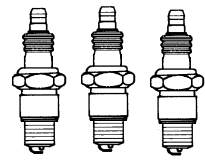

4-CYCLE SPARK PLUG

**Service Number
34046**

RL86C

† OHM120 * OVXL120,
‡ OHSK110-130 * OVXL/C120
OVM120 * OVXL125

Note:
*OVXL models with specification nos.
202700, 203000 and up, use RN4C.

† OHM 120 models with specification nos.
224000 and up, use RN4C.

‡ OHSK 110, 120, 130 models with
specification nos. 223000 and up, use
RN4C.

**Service Number
33636**

RJ17LM

H30-80 HS40-50
HM70-100 VLV-all

**Service Number
35552**

RL82C

HH140-160
OH120-160

Service Number 34645

RN4C

† OHM120 * OVXL/C120 OHV110-17
‡ OHSK110-130 * OVXL125 OVRM All
OVM120 OH180 TVT (V-Twin)
* OVXL120, OHH/OHSK40-130 OHM90-110

* OVXL models with specification nos. below 202700 use RL86C.

† OHM 120 models with specification nos. below 224000 use
RL86C.

‡ OHSK 110, 120, 130 models with specification nos. below
223000 use RL86C.

**Service Number
34277**

RJ8C

H22 HXL35
H25 LAV25-50
HH40-120 TVM125-220
HHM80 TVXL170-220
HMXL70 V40-80
HT30 VH40-100
HT35 VM70-100

**Service Number
35395**

RJ19LM

ECV100-120 TNT120
HMSK70-100 TVS75-120
HSK30-70 TVXL105
HSSK40-50 TVXL115
LEV80-120
TNT100
VSK100-120

2-CYCLE SPARK PLUG

**Service Number
611100**

RCJ6Y

TC300
TCH300

**Service Number
35395**

RJ19LM

TVS840
TVXL840

**Service Number
611049**

RCJ8Y

AH520 HSK850 HXL840
AH600 TC200
HSK600 TCH200
HSK840 Type 1500
HSK845

**Service Number
33636**

RJ17LM

AV520
AV600
TVS600

EUROPA MODELS

4-CYCLE SPARK PLUG

Service Number 29010007

J17LM

All Horizontal Models	Premier 153/173
BV	Prisma
BVL	Spectra
BVS	Synergy
Futura	Vantage
HTL	Centra
LAV	Legend

Service Number 29010023

RN4C

Premier 45/55	Synergy OHV	Futura OHV
Geotec OHV	Centra OHV	

2-CYCLE SPARK PLUG

Service Number 29010007

J17LM

AV85/125 TVS600
AV520/600
MV100S

NOTE: THE SERVICE NUMBERS LISTED BELOW
WILL GIVE CORRESPONDING CHAMPION
AND AUTOLITE SUBSTITUTIONS.

	Champion	Autolite
35395	- RJ-19LM	458
35552	- RL-82C	4092
34046	- RL-86C	425
34645	- RN-4C	403
33636	- J-17LM	245
34277	- RJ-8C	304
611100	- RCJ-6Y	2974
611049	- RCJ-8Y	2976

*NON CANADIAN APPLICATION

**SPARK PLUG AIR GAP ON ALL MODELS IS
.030 (.762 mm)**

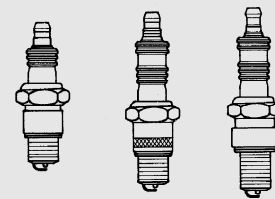

3/8" 1/2" 3/4"
9.525 mm 12.700 mm 19.050 mm

NOTE:
Not all spark plugs have the same heat range or reach. Using an incorrect spark plug can cause severe engine damage or poor performance. Tecumseh uses all three of the reaches shown.

Head Bolt Torque Sequence

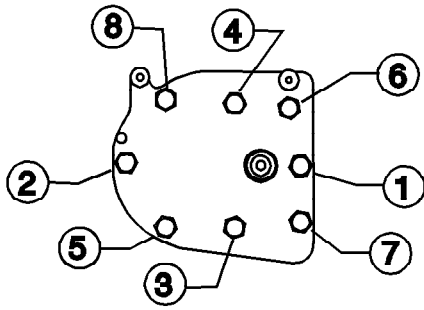

LEV, TVS75-120, H, HSK30-70, HS, HSSK40-50,
V50-70, TVXL105-115, TVM125-140
Torque bolts in 50 in. lb. (5.5 Nm) increments.

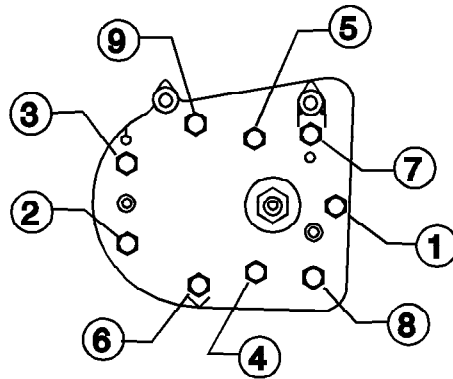

TVM-TVXL170-220, VM, HM, HMSK80-100
Torque bolts in 50 in. lb. (5.5 Nm) increments.

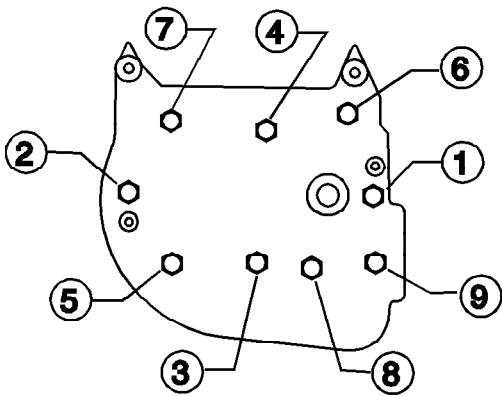

HH, VH80-120
Torque bolts in 50 in. lb. (5.5 Nm) increments.

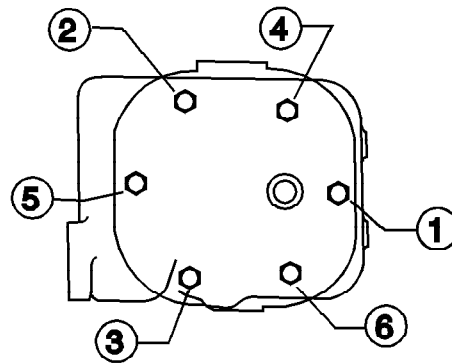

OHV11-17, OH120-180, OHM, OHSK, OVM, OVXL
Torque bolts in 60 in. lb. (7 Nm) increments.

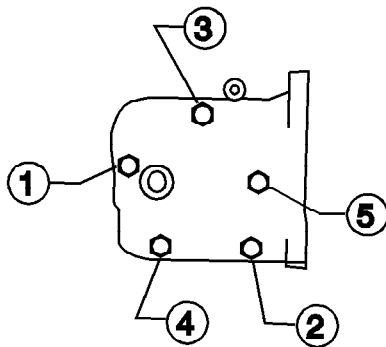

OVRM40-60, OHH, OHSK50-70
Torque bolts in 60 in. lb. (7 Nm) increments.

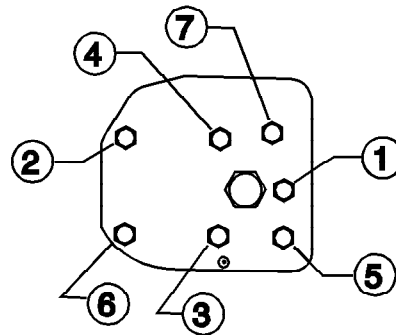

VLV40-6.75
Torque bolts in 50 in. lb. (5.5 Nm) increments.

Valve Clearance

Engine Model	Valve Clearance (Cold) * $\pm .002$ (.05 mm)	
	Intake Valve	Exhaust Valve
LAV35,50 LEV80-120 TVS75-120 ECV & TNT100-120 H30-35 & HS40-50	.006" (.004" - .008") .15 mm (.10 - .20 mm)	.006" (.004" - .008") .15 mm (.10 - .20 mm)
VLV40-6.75	.006"* (.15 mm)	.006"* (.15 mm)
TVT (V-Twin)	.004 (.10 mm)	.004 (.10 mm)
TVM125-220 V & VH50-70 H & HH50-70 HM70-100 & HHM80	.010"* (.25 mm)	.010"* (.25 mm)
OHSK80-130, OHM, OVM120 OVXL120 & OHV11-17	.004"* (.10 mm)	.004"* (.10 mm)
HH100-120	.010"* (.25 mm)	.020"* (.5 mm)
OH120-180	.005"* (.13 mm)	.010"* (.25 mm)
OVRM40-6.75 OHH/OHSK50-70	.004"* (.10 mm)	.004"* (.10 mm)
HSK60-70 HMSK80-100	.006"* (.15 mm)	.006"* (.15 mm)

Valve clearance is checked with engine cold and piston at T.D.C. of compression stroke.

NOTE: If the valve spring has dampening coils, it should be installed with the dampening coils away from the valve cap and retainers (opposite the keepers) or towards stationary surface.

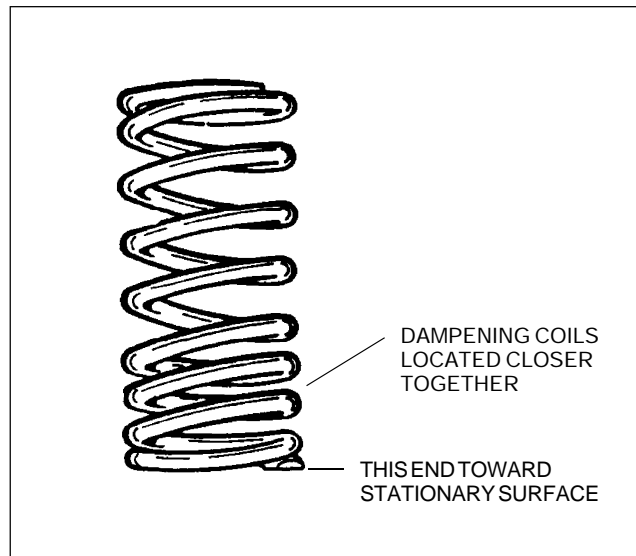

Recoil Quick Reference Parts

During the past few years we have introduced you to several new styles of recoil assemblies. These recoils are used on all small and medium frame series engines. To assist you in making repairs, we have developed the quick reference illustrations below. By looking at the direction and style of ribs between the inner and outer parts of the pulley, you can use this chart to obtain the correct parts. Due to various ropes and housings, these parts will not be shown. Please consult the regular parts list for a complete illustration or replacement.

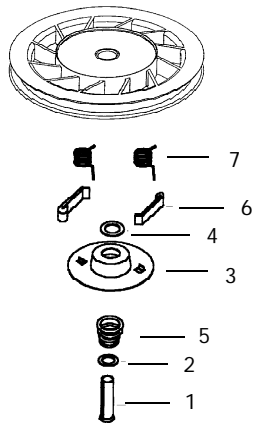

NOTE: The pulleys are identical but the retaining system changes between these two.

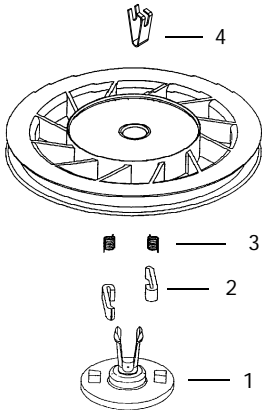

TYPE I

- | | | |
|---|---------|--------------------------|
| 1 | 590599A | Spring Pin (Incl. No. 4) |
| 2 | 590600 | Washer |
| 3 | 590696 | Retainer |
| 4 | 590601 | Washer |
| 5 | 590697 | Brake Spring |
| 6 | 590698 | Starter Dog |
| 7 | 590699 | Dog Spring |

TYPE II

- | | | |
|---|--------|-------------|
| 1 | 590740 | Retainer |
| 2 | 590616 | Starter Dog |
| 3 | 590617 | Dog Spring |
| 4 | 590760 | Locking Tab |

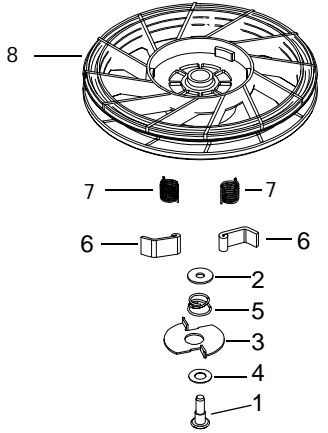
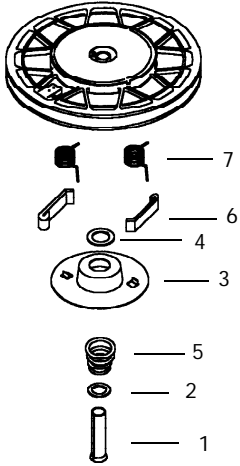
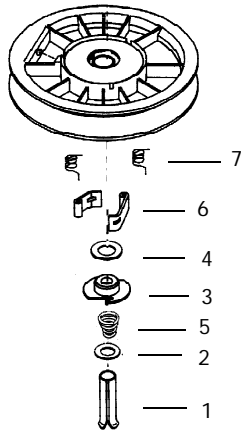

- | | | |
|---|---------|--------------------------|
| 1 | 590599A | Spring Pin (Incl. No. 4) |
| 2 | 590600 | Washer |
| 3 | 590679 | Retainer |
| 4 | 590601 | Washer |
| 5 | 590678 | Brake Spring |
| 6 | 590680 | Starter Dog |
| 7 | 590412 | Dog Spring |











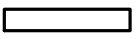
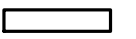
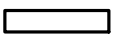



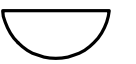





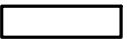

- | | | |
|---|---------|--------------------------|
| 1 | 590599A | Spring Pin (Incl. No. 4) |
| 2 | 590600 | Washer |
| 3 | 590696 | Retainer |
| 4 | 590601 | Washer |
| 5 | 590697 | Brake Spring |
| 6 | 590698 | Starter Dog |
| 7 | 590699 | Dog Spring |

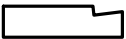
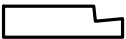
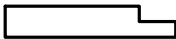
- | | | |
|---|---------|--------------|
| 1 | 590409A | Center Screw |
| 2 | 590755 | Washer |
| 3 | 590754 | Washer |
| 4 | 590753 | Washer |
| 5 | 590482 | Brake Spring |
| 6 | 590680 | Starter Dog |
| 7 | 590412 | Dog Spring |
| 8 | 590757 | Pulley |

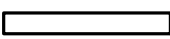
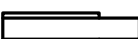
Tecumseh Flywheel Key Quick Reference

Identification Chart

Keys are drawn to full scale.

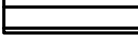
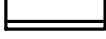
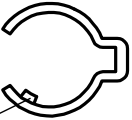
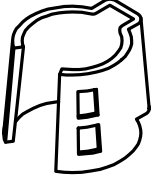
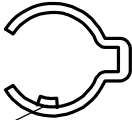
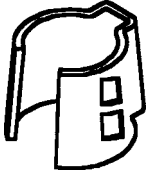
					
					
29410009 Steel	32589 Steel	611191 Steel	8446 Steel	650455 Steel	611054 Steel
					
					
610995 Steel	650496 Steel	610951 Steel	610961 Aluminum Alloy	30884 Steel	
					
					
27902 Aluminum Alloy	611154 Aluminum Alloy	650592 Aluminum Alloy	611004 Aluminum Alloy	611107 Aluminum Alloy	
					
Crankshaft Timing Tabs	611014A Point Ignition	Crankshaft Timing Tabs	611032 Solid State Ignition		

Primer Bulb Identification

Caution must be used when replacing carburetor primer bulbs. Using the wrong primer bulb could cause hard starting and operating problems. Currently, Tecumseh uses five different carburetor mounted bulbs. To avoid problems, use the Master Parts Manual for the correct application.

The primer bulbs offered feature two different shapes; derby and stepped (or hourglass).

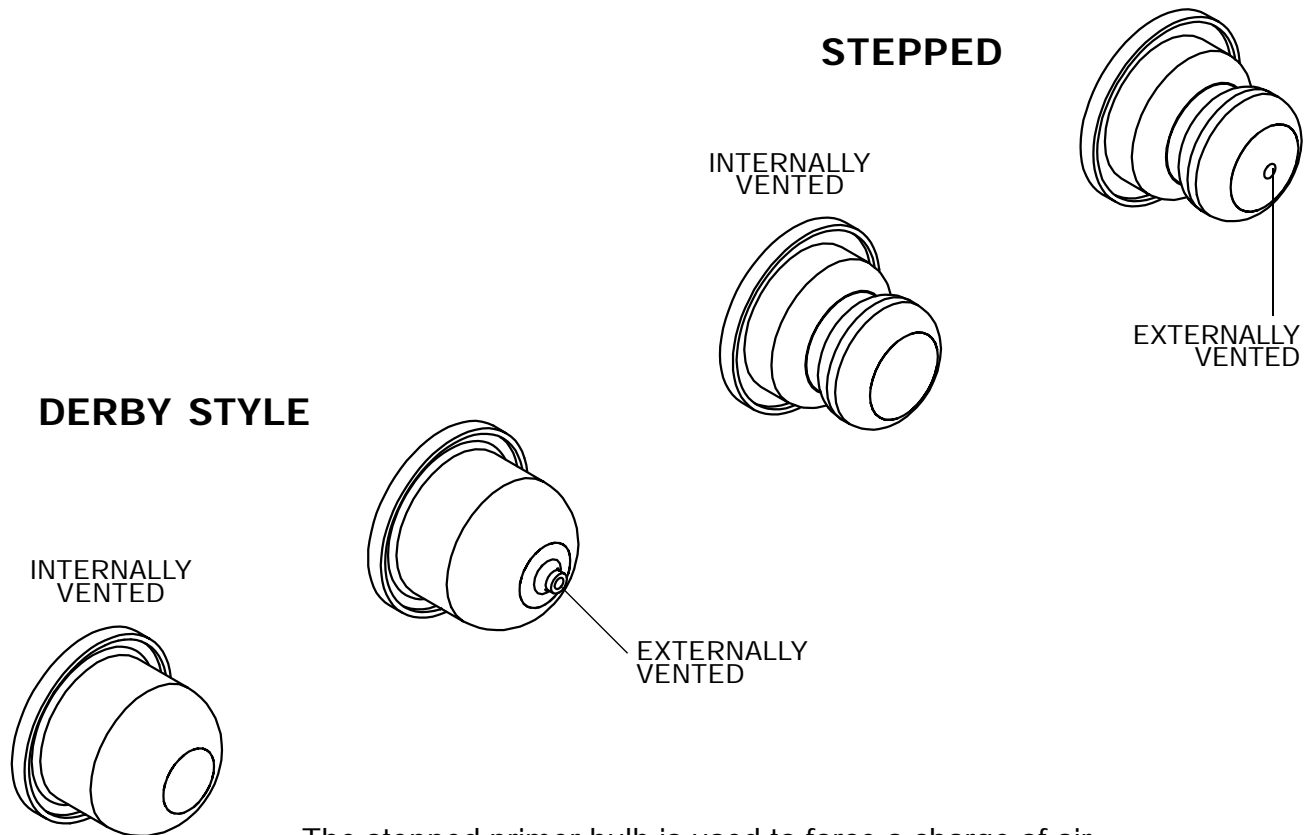

The stepped primer bulb is used to force a charge of air into the bowl through the atmospheric vent chamber. The sealing surface (as pictured), prevents air from going back into the air filter while priming.

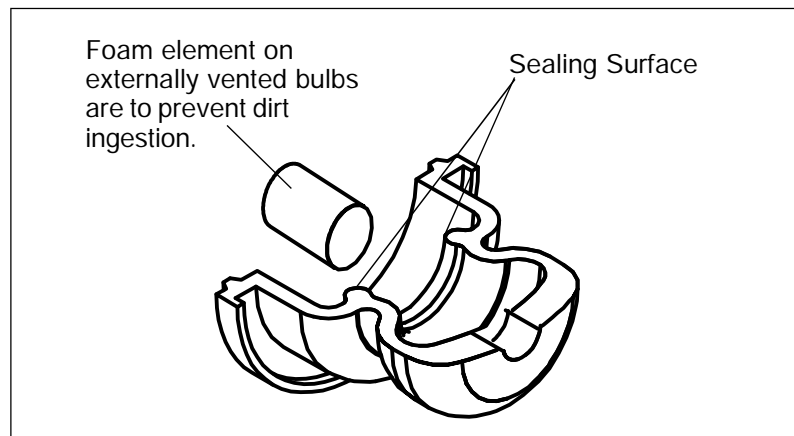

Piston Ring Installation

Piston ring orientation: Compression rings may have either an inside chamfer or an outside notch. Inside chamfers always face up towards the top of the piston. Outside notches, which are generally the second compression ring always face down towards the skirt of the piston.

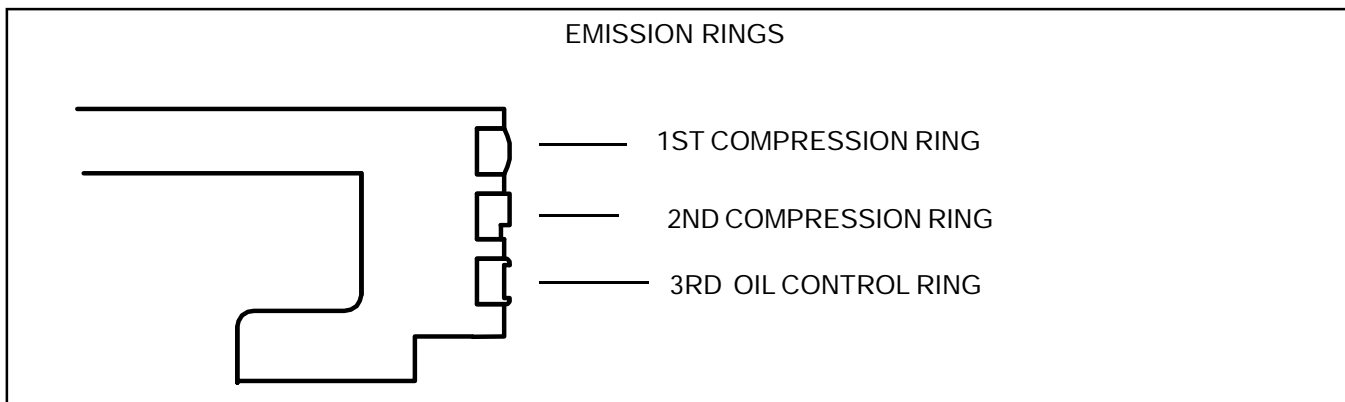
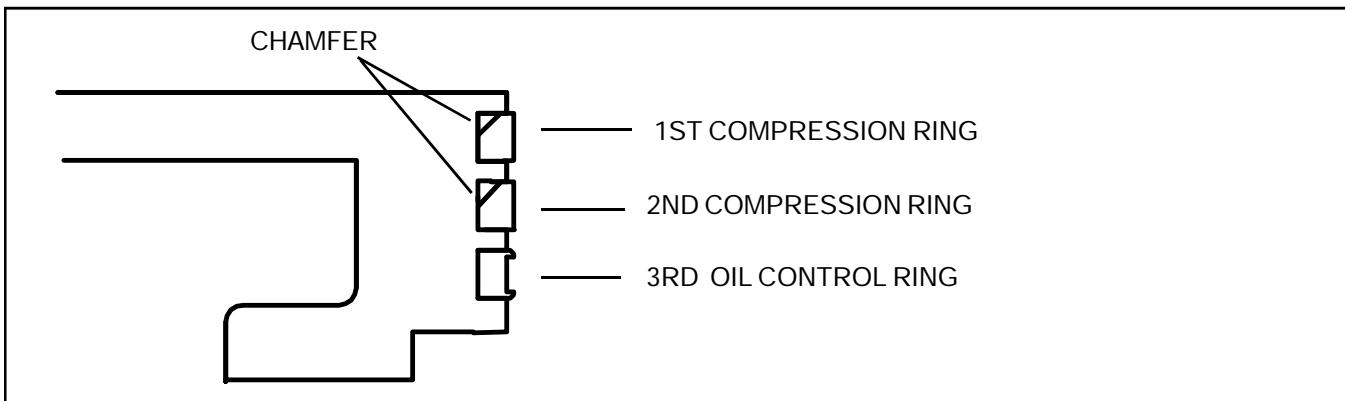

The following is the two types of ring expanders used by Tecumseh:

Top View

Side View

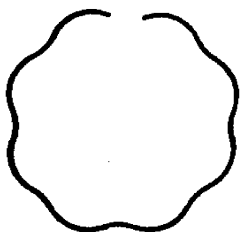

This expander is always used behind the second compression ring.

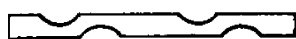
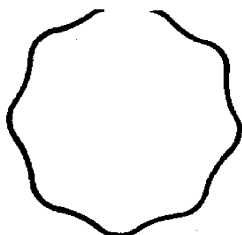

This expander is always used behind the oil control ring.

4 Cycle Quick Reference - Model Letter Designation

ECH - Exclusive Craftsman Horizontal	OHV - Overhead Valve Vertical (Medium Frame)
ECV - Exclusive Craftsman Vertical	OVM - Overhead Valve Vertical (Medium Frame)
H - Horizontal Shaft	OVRM - Overhead Valve Vertical (Small Frame) (Rotary Mower)
HH - Horizontal Heavy Duty (Cast Iron)	OVXL - Overhead Valve Vertical (Medium Frame) (Extra Life)
HHM - Horizontal Heavy Duty (Cast Iron) (Medium Frame)	TNT - Toro 'N' Tecumseh (Toro Exclusive Series)
HM - Horizontal Medium Frame	TVEM - Tecumseh Vertical European Model
HMSK - Horizontal Medium Frame (Snow King)	TVM - Tecumseh Vertical (Medium Frame) (Replaces V & VM)
HMXL - Horizontal Medium Frame (Extra Life)	TVS - Tecumseh Vertical Styled
HS - Horizontal Small Frame	TVT - Tecumseh Vertical Twin
HSSK - Horizontal Small Frame (Snow King)	TVXL - Tecumseh Vertical (Extra Life)
HXL - Horizontal (Extra Life)	V - Vertical Shaft
LAV - Lightweight Aluminum Frame Vertical	VH - Vertical Heavy Duty (Cast Iron)
LEV - Low Emissions Vertical	VLV - Vector Lightweight Vertical
OH - Overhead Valve Heavy Duty (Cast Iron)	VLXL - Vector Lightweight Vertical (Extra Life)
OHH - Overhead Valve Horizontal	VM - Vertical Shaft (Medium Frame)
OHM - Overhead Valve Heavy Duty Horizontal (Medium Frame)	VSK - Vertical Snow King
OHSK - Overhead Valve Horizontal (Snow King)	

LOCATING AND READING ENGINE MODEL AND SPECIFICATION THE FOLLOWING WILL BE NEEDED TO LOCATE PARTS FOR YOUR ENGINE.

	Model	Specification	Serial (DOM)
ENGINE:	TVM195	150288G	8150C

ENGINE MODEL TVM195	SPEC NO. 150288G	D.O.M (SERIAL NO) 8150C
-------------------------------	----------------------------	-----------------------------------

Typical Engine I.D. Label

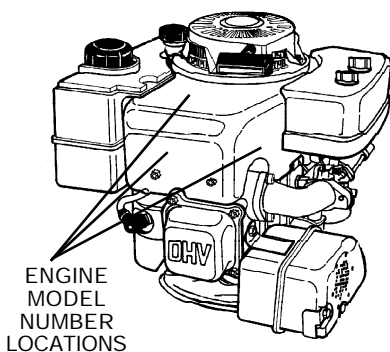

IMPORTANT ENGINE INFORMATION
TECUMSEH PRODUCTS CO.
 THIS ENGINE MEETS 1995-1998 CALIF/US EPA PH1 APPLICABLE EMISSION REGULATIONS FOR ULGE ENGINES FUEL REGULAR UNLEADED OIL SAE 30

ENGINE MODEL	TVM195 150288G (E)
ENGINE FAMILY	STP318U1G2EA
DISPLACEMENT	318 D.O.M. (S E R) 8150 C

CAUTION FOR PERSONAL PROTECTION REFER TO OWNER'S MANUAL FOR IMPORTANT SAFETY AND MAINTENANCE INFORMATION

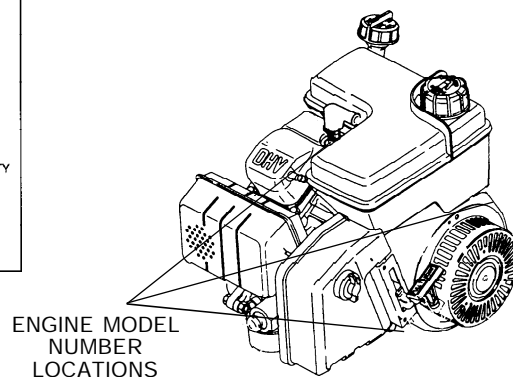

4 Cycle Quick Reference for Spec. Numbers-To-Model Designation

HORIZONTAL 4-CYCLE ENGINES

15000 - H22	67000 - HS & HSSK50	115000 - HH100	159950 - HMSK110
25000 - H25	68000 - OHH50	120000 - HH120	160000 - HH & OH140
26000 - OHH45	68500 - OHSK50	130000 - H70	170000 - HH150 & 160
35000 - H30	69000 - OHH55	130200 - HSK70	170000 - OH160
35400 - HSK30	69500 - OHSK55	132000 - HM & HMSK70	175000 - OH120
45000 - H & HT35	71100 - OHH60	132500 - HMXL70	180000 - OH180
45400 - HSK35	71500 - OHSK60	140000 - HH70	190000 - HHM80
47000 - HXL35	71700 - OHH65	146000 - ECH90	220000 - OHM120
55000 - H40	71900 - OHSK65	155000 - H & HM80	221000 - OHSK110
55200 - HS & HSSK40	72500 - OHSK70	155000 - HMSK80	222000 - OHSK120
55500 - HSK40	75000 - H60	155800 - HM85	223000 - OHSK90
55700 - H40	76000 - HSK60	155900 - HM & HMSK85	223400 - OHSK110
55800 - H40	85000 - HH40	156000 - HM90	223600 - OHSK120
55900 - HSSK40	95000 - HH50	156500 - HMSK90	223700 - OHSK125
65000 - H50	105000 - HH60	159000 - HM & HMSK100	223800 - OHSK130
65300 - HSK50	110000 - HH80	159900 - HMSK105	224600 - OHM120

VERTICAL 4-CYCLE ENGINES

10000 - TNT100	125000 - V70
12000 - TNT120	127000 - VM70, TVM170
20000 - LAV25, OVRM55	127200 - TVXL170
20500 - OVRM105	135000 - VH70
21000 - OVRM60	145000 - ECV100
21800 - OVRM60	147000 - ECV105
22000 - OVRM65	148000 - VH80
30000 - LAV30	149000 - VH100
33000 - TVS75	150000 - V & VM80, TVM195
40000 - LAV35	150200 - TVM & TVXL195
42000 - OVRM905 (SearsOnly)	150500 - TVM195
42600 - OVRM40, OVRM45 (PremierEngine)	151000 - ECV110, TVM195
42900 - OVRM40 (HighTechLook)	151500 - TVM220
43000 - TVS90	152000 - ECV120
43600 - TVS90 (PremierEngine)	157000 - VM100, TVM220
43700 - TVS90, TVXL90	157200 - TVM & TVXL220
43900 - TVS90 (HighTechLook)	157400 - TVM220
44000 - TVS100	200000 - OVM120
44600 - TVS100 (PremierEngine)	202000 - OVXL120, OVXL125
44800 - TVS100	202200 - OVXL120 (I/C)
46000 - TVS90, TVXL90	202300 - OHV11, OHV115
46600 - TVS90	202400 - OVXL125
48000 - TVS90	202500 - OHV115
50000 - V40	202600 - OVXL125 (I/C)
50200 - LAV40	202700 - OHV12, OVXL120 (Tec.1200)
52600 - OVRM50, OVRM55 (PremierEngine)	203000 - OHV125, OVXL125 (Tec.1250)
52800 - OVRM50, OVRM55	203200 - OHV13
52900 - OVRM50, OVRM55 (HighTechLook)	203500 - OVXL125 (Tec.1250I/C), OHV13/135
53000 - TVS105	203600 - OHV14/140
53600 - TVS105 (PremierEngine)	203800 - OHV145
53800 - TVS105	204000 - OHV15/150
53900 - TVS105 (HighTechLook)	204200 - OHV16/160
54000 - TVXL105	204400 - OHV165
56000 - TVS105, TVS & TVXL115	204500 - OHV155
56600 - TVS105, TVS115 (PremierEngine)	204600 - OHV17/170
56800 - TVS115	204800 - OHV175
56900 - TVS105, TVS115 (HighTechLook)	206000 - OHV110
57000 - TVS & TVXL115	206200 - OHV115
57600 - TVS115 (PremierEngine)	206400 - OHV120
57800 - TVS115	206600 - OHV125
57900 - TVS115 (HighTechLook)	206800 - OHV130
60000 - V50, TVM125	206900 - OHV135
61000 - TVS & TVXL115	335000 - LEV100
61600 - TVS & TVXL115	338000 - LEV100
61800 - TVS115	338500 - VSK100
61900 - TVS115	340000 - LEV100
62000 - LAV50	345000 - LEV100
62100 - LAV50 & TVS115	350000 - LEV115
63000 - TVS120	355000 - LEV115
63200 - TVS120, TVEM120	360000 - LEV115
63600 - TVS120 (PremierEngine)	361000 - LEV120
63900 - TVS120 (HighTechLook)	361400 - VSK120
66000 - TVS120	400000 - VLV40
66100 - TVS120	500000 - ULT, VLV B24, VLXL50, & VLV126
70000 - V60, TVM140	501000 - ULT, VLV, VLXL55, & VLV126
80000 - VH40	502000 - ULT, VLV60, VLV65, & VLV126
90000 - VH50	502500 - VLV65, VLV66
100000 - VH60	600400 - TVT691

Metric Conversions Factors (approximate)

Conversions TO Metric Measures

	Symbol	When You Know	Multiply By	To Find	Symbol
LENGTH	in.	inches	25.4	millimeters	mm
	in.	inches	2.54	centimeters	cm
	ft.	feet	30	centimeters	cm
	yd.	yards	0.9	meters	m
	mi.	miles	1.6	kilometers	km
MASS (weight)	oz.	ounces	28	grams	g
	lb.	pounds	0.45	kilograms	kg
VOLUME	tsp.	teaspoons	5	milliliters	ml
	Tbsp.	tablespoons	15	milliliters	ml
	fl. oz.	fluid ounces	30	milliliters	ml
	c	cups	0.24	liters	l
	pt.	pints	0.47	liters	l
	qt.	quarts	0.95	liters	l
	gal.	gallons	3.8	liters	l
	in ³	cubic inch	16.39	cubic centimeters	cc
TORQUE	in./lbs.	inch/pounds	.113	Newton meters	Nm
	ft./lbs.	foot/pounds	1.36	Newton meters	Nm
TEMP.	°F	Fahrenheit Temp.	subtract 32 then x .555	Celsius	°C

Conversions FROM Metric Measures

	Symbol	When You Know	Multiply By	To Find	Symbol
LENGTH	mm	millimeters	0.04	inches	in.
	cm	centimeters	0.4	inches	in.
	m	meters	3.3	feet	ft.
	m	meters	1.1	yards	yd.
	km	kilometers	0.6	miles	mi.
MASS (weight)	g	grams	0.035	ounces	oz.
	Kg	kilograms	2.2	pounds	lb.
VOLUME	ml	milliliters	0.0338	fluid ounces	fl. oz.
	l	liters	2.1	pints	pt.
	l	liters	1.06	quarts	qt.
	l	liters	0.26	gallons	gal.
	cm ³	cubic centimeters	0.061	cubic inches	in ³
TORQUE	Nm	Newton meters	8.85	inch/pounds	in./lb.
	Nm	Newton meters	.738	foot/pounds	ft./lb.
TEMP	°C	Celsius Temp.	x 1.8 then add 32	Fahrenheit Temp.	°F