

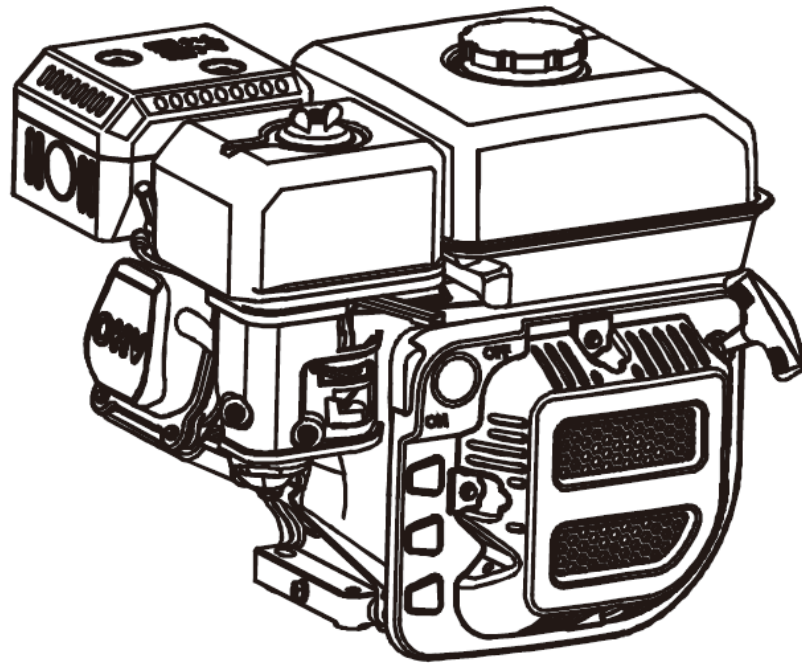

**GASOLINE ENGINE
R100-R440 HORIZONTAL SHAFT
SERVICE MANUAL**



**CHONGQING RATO POWER
MANUFACTURING CORPORATION**

This manual contains information about how to perform routine maintenance and how to do troubleshooting.

Keep this manual handy, so you can refer to it at any time.

This service manual describes correct methods for maintaining this equipment. If any personal casualty or equipment damage is caused due to disregard of our rules, our company does not assume any responsibility.

NOTICE:

Copyright is reserved, and no part of this publication may be reproduced without RATO Company's written permission.

SAFETY MESSAGES

Your safety and the safety of others are very important. We have provided important safety messages in this manual and on the generator. Please read these messages carefully.

A safety message alerts you to potential hazards that could injure you or others. Each safety message is preceded by a safety alert symbol  and one of three words: DANGER, WARNING, or CAUTION. These messages mean:

 **DANGER**

You WILL be KILLED or SERIOUSLY INJURED if you don't follow instructions.

 **WARNING**

You CAN be KILLED or SERIOUSLY INJURED if you don't follow instructions.

 **CAUTION**

You CAN be INJURED if you don't follow instructions.

NOTICE

Your generator or other property could be damaged if you don't follow instructions.

CONTENTS

1. INTRODUCTION	1
1-1 PARTS DESCRIPTION	1
1-2 SPECIFICATION	2
1-3 SERVICE LIMIT	5
2. DIMENSIONS AND TORQUE	19
2-1 ENGINE DIMENSIONS	19
2-1-1 R100	19
2-1-2 R160/R180/R200/R210/R225	19
2-1-3 R270/R280/R300	20
2-1-4 R390/R420/R440	21
2-2 TORQUE VALUES	22
2-2-1 torque values	22
2-3 STANDARD Torque values	24
3. MAINTENANCE	25
3-1. Maintenance schedule	25
3-2 engine oil	26
3-3 Air cleaner	27
3-4 Cleaning of the fuel filter	27
3-5 spark plug cleaning and	28
adjusting	28
3-6 valve clearance adjustment	28
3-7 governor	29
4. DISASSEMBLING AND SERVICING	30
4-1 Troubleshooting	30
4-1-1 Hard starting	30
4-1-2 Engine lacks power	2
4-1-3 Speed is unstable	3
4-1-4 Motor is unable to start	3
4-1-5 Exhaust gas color is abnormal	4

4-1-6 Unable to ignite	4
4-1-7 Oil alert system malfunction	5
4-1-8 GASOLINE ENGINE IS OVERERHEATED	5
4-2 Preparation of servicing	6
4-2-1 Safety precautions	6
4-3 DisASSEMBLING chart	46
4-4 Engine	47
4-4-1 Recoil starter	48
4-4-2 Flywheel	50
4-4-3 Air cleaner	52
4-4-4 Carburetor	54
4-4-5 Cylinder head /valve	57
4-4-6 Crankshaft/piston	63
4-4-7 Starting control box	71

1. INTRODUCTION

1-1 PARTS DESCRIPTION

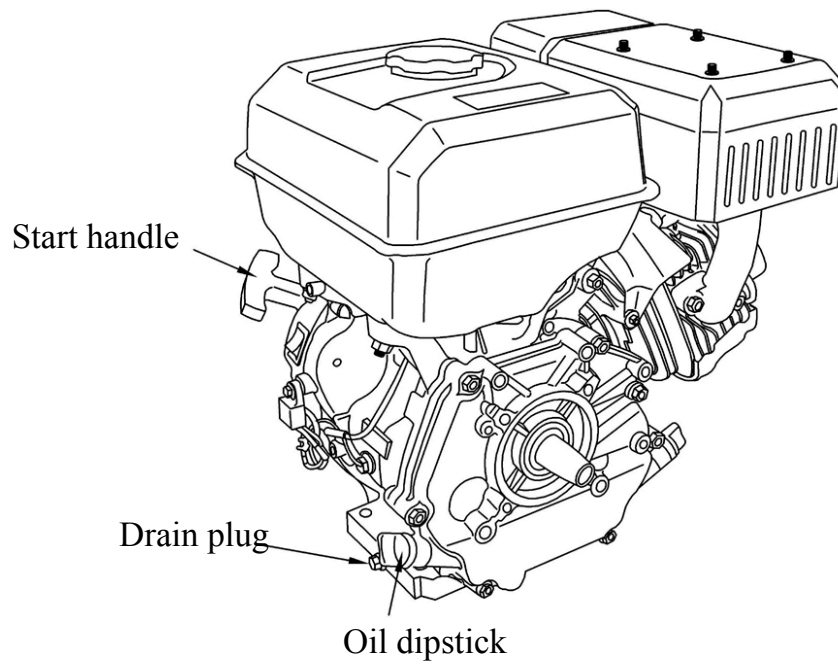
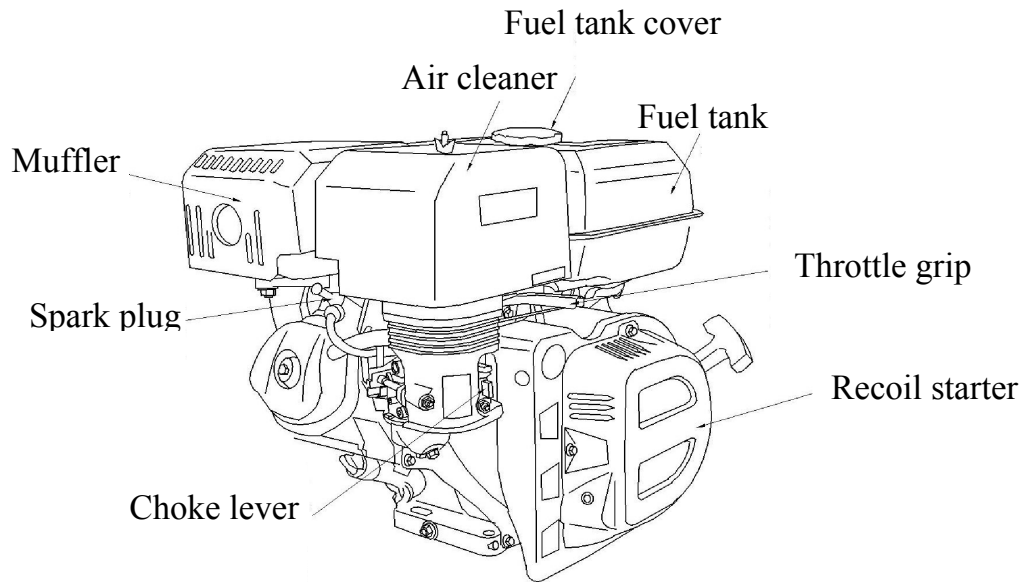

1-2 SPECIFICATION

Model	R100	R160
items		
L×W×H	310×290×320mm	390×320×345mm
Dry Weight	8.8 kg	15.5kg
Engine Type	4-stroke, OHV, single cylinder	
Displacement	98 cm ³	163cm ³
Compression Ratio	8.5±0.3:1	
Bore×Stroke	56×40 mm	68×45mm
Maximum Output Power	1.8 / 3600 rpm	3.4kW/3,600rpm
Maximum Torque	4.7N·m/2500rpm	9N·m/2,500rpm
Cooling System	Forced Air-cooled	
Ignition System	Transistorized Magneto Ignition(TCI)	
Spark Plug	BPR6ES(NGK), NHSP LD F7RTC, F7TC	
Lubrication System	Forced Splash	
PTO Shaft Rotation	Counterclockwise	
Model	R180	R200
items		
L×W×H	390×320×345mm	390×320×345mm
Dry Weight	16kg	16kg
Engine Type	4-stroke, OHV, single cylinder	
Displacement	179cm ³	196cm ³
Compression Ratio	8.5:1	
Bore×Stroke	65×54mm	68×54mm
Maximum Output Power	3.5kW/3,600rpm	4.0kW/3,600rpm
Maximum Torque	9N·m/2,500rpm	11N·m/2,500rpm
Cooling System	Forced Air-cooled	
Ignition System	Transistorized Magneto Ignition(TCI)	
Spark Plug	BPR6ES(NGK), NHSP LD F7RTC, F7TC	
Lubrication System	Forced Splash	
PTO Shaft Rotation	Counterclockwise	
Model	R210	R225
items		
L×W×H	390×320×345mm	390×320×345mm

Dry Weight	16.5 kg	16.5kg
Engine Type	4-stroke, OHV, single cylinder	
Displacement	212 cm ³	223cm ³
Compression Ratio	8.5±0.3	
Bore×Stroke	70×55 mm	70×58mm
Maximum Output Power	4.2 / 3600 rpm	4.4kW/3,600rpm
Maximum Torque	12N·m/2500rpm	13N·m/2,500rpm
Cooling System	Forced Air-cooled	
Ignition System	Transistorized Magneto Ignition(TCI)	
Spark Plug	BPR6ES(NGK), NHSP LD F7RTC, F7TC	
Lubrication System	Forced Splash	
PTO Shaft Rotation	Counterclockwise	

Items	Model	
	R270	R280
L×W×H	420×395×430mm	420×395×430mm
Dry Weight	26kg	26kg
Engine Type	4-stroke, OHV, single cylinder	
Displacement	270cm ³	277cm ³
Compression Ratio	8.2: 1	
Bore×Stroke	77×58mm	78×58mm
Maximum Output Power	5.8kW/3,600rpm	6kW/3,600rpm
Maximum Torque	16.8N·m /2,500rpm	18N·m /2,500rpm
Cooling System	Forced Air-cooled	
Ignition System	Transistorized Magneto Ignition(TCI)	
Spark Plug	BPR6ES(NGK), NHSP LD F7RTC, F7TC	
Lubrication System	Forced Splash	
PTO Shaft Rotation	Counterclockwise	
Items	Model	
	R300	R390
L×W×H	420×395×430mm	465×415×440mm
Dry Weight	26kg	27.5kg
Engine Type	4-stroke, OHV, single cylinder	
Displacement	301cm ³	389cm ³

Compression Ratio	8.2: 1	8: 1
Bore×Stroke	80×60mm	88×64mm
Maximum Output Power	6kW/3,600rpm	7.6kW/3,600rpm
Maximum Torque	18N·m /2,500rpm	23N·m /2,500rpm
Cooling System	Forced Air-cooled	
Ignition System	Transistorized Magneto Ignition(TCI)	
Spark Plug	BPR6ES(NGK), NHSP LD F7RTC, F7TC	
Lubrication System	Forced Splash	
PTO Shaft Rotation	Counterclockwise	
Model	R420	R440
Items		
L×W×H	465×415×440mm	465×415×440mm
Dry Weight	28kg	28.5kg
Engine Type	4-stroke, OHV, single cylinder	
Displacement	420cm ³	438cm ³
Compression Ratio	8.5: 1	8.5: 1
Bore×Stroke	90×66mm	92×66mm
Maximum Output Power	8.5kW/3,600rpm	9.8kW/3,600rpm
Maximum Torque	25N·m /2,500rpm	27N·m /2,500rpm
Cooling System	Forced Air-cooled	
Ignition System	Transistorized Magneto Ignition(TCI)	
Spark Plug	BPR6ES(NGK), NHSP LD F7RTC, F7TC	
Lubrication System	Forced Splash	
PTO Shaft Rotation	Counterclockwise	

1-3 SERVICE LIMIT

1-3-1 R100

Parts	Item	Standard Value	Service Limit	
Gasoline Engine	Maximum Speed (No load)	3850rpm	--	
	Cylinder Compression	□0.9Mpa (1400rpm)	--	
Cylinder	Cylinder Bore I.D.	56-56.015mm	56.165	
Cylinder Head	Warpage	--	0.1	
Piston	Skirt O.D.	55.975-55.985mm	55.9	
	Piston-to-Cylinder Clearance	0.015-0.04mm	0.12	
	Piston Pin Bore I.D.	14.002-14.008mm	14.048	
	Piston Pin O.D	13.992-13.998mm	13.954	
	Piston Pin-to-Piston Pin Bore Clearance	0.004-0.016mm	0.03	
Piston Rings	Ring Side Clearance: Top /Second Ring	0.03-0.07mm	0.15	
	Oil Ring	--	--	
	Ring End Gap: Top /Second Ring	0.15-0.3mm	1	
	Oil Ring	0.1-0.6mm	1	
	Ring Width: Top /Second/Oil Ring	1.5mm 2.5mm	1.37 2.37	
Connecting Rod	Small End I.D	14.011-14.022mm	14.05	
	Big End I.D	23.02-23.03mm	23.05	
	Big End Oil Clearance	0.035-0.055mm	0.12	
	Small End Side Clearance	0.1-0.7mm	1.1	
Crankshaft	Crankshaft Pin O.D	22.975-22.985mm	22.945	
Valves	Valve Clearance	IN 0.15±0.02mm EX 0.20±0.02mm	-- --	
	Stem O.D	IN 5.465-5.48mm EX 5.445-5.46mm	5.318 5.275	
	Guide I.D	IN / EX 5.50-5.512mm	5.572	
	Stem-to-Guide Clearance	IN 0.015-0.052mm EX 0.015-0.052mm	0.1 0.12	
	Seat Width	0.8mm	2.0	
	Spring Free Length	25.0mm	24	
	Camshaft	Cam Height IN	29.4mm	29.2

	EX	29.4mm	29.2
	Journal O.D	12.966-12.986mm	12.91
Crankcase Cover	Camshaft Holder I.D.	13.0-13.018mm	13.048

1-3-2 R160/R200

Parts	Item	Standard Value	Service Limit	
Gasoline Engine	Maximum Speed (No Load)	3750-3810rpm	--	
	Cylinder Compression	$\geq 1.17\text{Mpa}$ (1400rpm)	--	
Cylinder	Cylinder Bore I.D.	68.0mm	68.165mm	
Cylinder Head	Warpage	--	0.10mm	
Piston	Skirt O.D.	67.985mm	67.845mm	
	Piston-to-Cylinder Clearance	0.015-0.05mm	0.12mm	
	Piston Pin Bore I.D.	18.002mm	18.048mm	
	Piston Pin O.D.	18.0mm	17.954mm	
	Piston Pin-to-Piston Pin Bore Clearance	0.002-0.014mm	0.06mm	
Piston Rings	Ring Side Clearance: Top /Second Ring	0.015-0.045mm	0.15mm	
	Oil Ring	--	--	
	Ring End Gap: Top /Second Ring	0.2-0.4mm	1.0mm	
	Oil Ring	0.15-0.35mm	1.0mm	
	Ring Width: Top /Second/Oil Ring	1.5mm	1.37mm	
		2.5mm	2.37mm	
Connecting Rod	Small End I.D.	18.002mm	18.07mm	
	Big End I.D.	30.02mm	30.066mm	
	Big End Oil Clearance	0.040-0.063mm	0.12mm	
	Small End Side Clearance	0.1-0.7mm	1.1mm	
Crankshaft	Crankshaft pin O.D	29.98mm	29.92mm	
Valve	Valve Clearance	IN	0.15±0.02mm	--
		EX	0.20±0.02mm	--
	Stem O.D	IN	5.48mm	5.318mm
		EX	5.44mm	5.275mm
	Guide I.D	IN / EX	5.50mm	5.572mm
	Stem-to-Guide Clearance	IN	0.02-0.044mm	0.1mm
		EX	0.06-0.087mm	0.12mm
	Seat Width	0.8mm	2.0mm	

	Spring Free Length		34.0mm	32.5mm
Camshaft	Cam Height	IN	27.7mm	27.45mm
		EX	27.75mm	27.50mm
	Journal O.D		13.984mm	13.916mm
Crankcase Cover	Camshaft Holder I.D.		14.0mm	14.048mm
Carburetor	Main Jet		0.85	--
	Float Height		13.7±1.5mm	--
	Pilot Screw Opening		2-1/8 circle	--
Spark Plug	Gap		0.7-0.8mm	--
Spark Plug Cap	Resistance		7.5-12.5kΩ	--
Ignition Coil	Resistance	Primary Coil	0.8-1.0Ω	--
		Secondary Coil	5.9-7.1kΩ	--
	Air gap		0.4-0.6mm	--

1-3-3 R180

Parts	Item	Standard Value	Service Limit
Gasoline Engine	Maximum Speed (No Load)	3750-3810rpm	--
	Cylinder Compression	□1.17Mpa (1400rpm)	--
Cylinder	Cylinder Bore I.D.	70.0mm	70.165mm
Cylinder Head	Warpage	--	0.10mm
Piston	Skirt O.D.	69.985mm	69.845mm
	Piston-to-Cylinder Clearance	0.015-0.05mm	0.12mm
	Piston Pin Bore I.D.	18.002mm	18.048mm
	Piston Pin O.D.	18.0mm	17.954mm
	Piston Pin-to-Piston Pin Bore Clearance	0.002-0.014mm	0.06mm
Piston Rings	Ring Side Clearance:	0.015-0.045mm	0.15mm
		Top /Second Ring	--
		Oil Ring	--
	Ring End Gap:	0.2-0.4mm	1.0mm
		Top /Second Ring	0.15-0.35mm
	Oil Ring	1.5mm	1.37mm
	Ring Width:	2.5mm	2.37mm
	Top /Second/Oil Ring		
Connecting Rod	Small End I.D.	18.011mm	18.07mm
	Big End I.D.	30.02mm	30.066mm

	Big End Oil Clearance		0.040-0.063mm	0.12mm
	Small End Side Clearance		0.1-0.7mm	1.1mm
Crankshaft	Crankshaft pin O.D		29.98mm	29.92mm
Valve	Valve Clearance	IN	0.15±0.02mm	--
		EX	0.20±0.02mm	--
	Stem O.D	IN	5.48mm	5.318mm
		EX	5.44mm	5.275mm
	Guide I.D	IN / EX	5.50mm	5.572mm
	Stem-to-Guide Clearance	IN	0.02-0.044mm	0.1mm
		EX	0.06-0.087mm	0.12mm
	Seat Width		0.8mm	2.0mm
	Spring Free Length		34.0mm	32.5mm
Camshaft	Cam Height	IN	27.7mm	27.45mm
		EX	27.75mm	27.50mm
	Journal O.D		14.184mm	14.166mm
Crankcase Cover	Camshaft Holder I.D.		14.2mm	14.048mm
Carburetor	Main Jet		0.85	--
	Float Height		13.7±1.5mm	--
	Pilot Screw Opening		2-1/8 circle	--
Spark Plug	Gap		0.7-0.8mm	--
Spark Plug Cap	Resistance		7.5-12.5kΩ	--
Ignition Coil	Resistance	Primary Coil	0.8-1.0Ω	--
		Secondary Coil	5.9-7.1kΩ	
	Air gap		0.4-0.6mm	--

1-3-4 R210/R225

Parts	Item	Standard Value	Service Limit
Gasoline Engine	Maximum Speed (No Load)	3750-3810rpm	--
	Cylinder Compression	□1.17Mpa (1400rpm)	
Cylinder	Cylinder Bore I.D.	70.0mm	70.165mm
Cylinder Head	Warpage	--	0.10mm
Piston	Skirt O.D.	69.985mm	69.845mm
	Piston-to-Cylinder Clearance	0.015-0.05mm	0.12mm

	Piston Pin Bore I.D.		18 .002mm	18.048mm
	Piston Pin O.D.		18.0mm	17.954mm
	Piston Pin-to-Piston Pin Bore Clearance		0.002-0.014mm	0.06mm
Piston Rings	Ring Side Clearance: Top /Second Ring		0.015-0.045mm	0.15mm
	Oil Ring		--	--
	Ring End Gap: Top /Second Ring		0.2-0.4mm	1.0mm
	Oil Ring		0.15-0.35mm	1.0mm
	Ring Width: Top /Second/Oil Ring		1.5mm	1.37mm
			2.5mm	2.37mm
Connecting Rod	Small End I.D.		18.011mm	18.07mm
	Big End I.D.		30.02mm	30.066mm
	Big End Oil Clearance		0.040-0.063mm	0.12mm
	Small End Side Clearance		0.1-0.7mm	1.1mm
Crankshaft	Crankshaft pin O.D		29.98mm	29.92mm
Valve	Valve Clearance	IN	0.15±0.02mm	--
		EX	0.20±0.02mm	--
	Stem O.D	IN	5.48mm	5.318mm
		EX	5.44mm	5.275mm
	Guide I.D	IN / EX	5.50mm	5.572mm
	Stem-to-Guide Clearance	IN	0.02-0.044mm	0.1mm
		EX	0.06-0.087mm	0.12mm
	Seat Width		0.8mm	2.0mm
	Spring Free Length		34.0mm	32.5mm
Camshaft	Cam Height	IN	27.7mm	27.45mm
		EX	27.75mm	27.50mm
	Journal O.D		13.984mm	13.916mm
Crankcase Cover	Camshaft Holder I.D.		14.0mm	14.048mm
Carburetor	Main Jet		0.85	--
	Float Height		13.7±1.5mm	--
	Pilot Screw Opening		2-1/8 circle	--
Spark Plug	Gap		0.7-0.8mm	--
Spark Plug Cap	Resistance		7.5-12.5kΩ	--
Ignition Coil	Resistance	Primary Coil	0.8-1.0Ω	--

	Secondary Coil	5.9-7.1kΩ	--
	Air gap	0.4-0.6mm	--

1-3-5 R270

Parts	Item	Standard	Service limit	
Engine	Maximum speed (No load)	3150-3180rpm	--	
	Cylinder compression	$\cong 1.37\text{Mpa}$ (1400rpm)	--	
Cylinder head	Sleeve I.D.	77-77.017mm	77.17mm	
Cylinder head	Warpage	--	0.10mm	
Piston	Skirt O.D.	76.965-76.985mm	76.85mm	
	Piston-to-cylinder clearance	0.015-0.052mm	0.12mm	
	Piston pin bore I.D.	18.002-18.008mm	18.042mm	
	Piston pin O.D.	17.994-18mm	17.95mm	
	Piston pin-to-piston pin bore clearance	0.002-0.014mm	0.08mm	
Piston rings	Ring side clearance: first/ second	0.015-0.045mm	0.15mm	
	Oil	--	--	
	Ring end gap: first/second	0.2-0.4mm	1.0mm	
	Oil	0.2-0.7mm	1.0mm	
	Ring width: first/second	1.5mm	1.37mm	
Oil	2.0mm	2.0mm		
Connecting rod	Small end I.D	18.005-18.02mm	18.07mm	
	Big end I.D	33.025-33.039mm	30.07mm	
	Big end oil clearance	0.040-0.066mm	0.12mm	
	Big end side clearance	0.1-0.7mm	1.0mm	
Crankshaft	Crankshaft pin O.D	32.975-32.985mm	32.92mm	
Valves	Valve clearance	IN	0.15 ± 0.02mm	--
	EX		0.20 ± 0.02mm	--
	Stem O.D.	IN	6.575-6.59mm	6.44mm
	EX		6.535-6.55mm	6.4mm
	Guide I.D.	IN/EX	6.6-6.612mm	6.66mm
	Stem clearance	IN	0.01-0.037mm	0.11mm
	EX		0.05-0.077mm	0.13mm
	Seat width		1.1mm	2.0mm
Spring free length			37.5mm	

			39.0mm	
camshaft	Cam height	IN	32.9-33.1mm	32.88mm
		EX	32.50-32.70mm	32.48mm
	Journal O.D		15.966-15.984mm	15.92mm
Crankcase cover	Camshaft holder I.D		16.0mm	16.048mm
Carburetor	Main jet		0.88	--
	Float height		13.2mm	--
	Pilot screw opening		2-7/8 turns	--
Spark plug	Gap		0.7-0.8mm	--
Spark plug cap	Resistance		7.5-12.5k Ω	--
Ignition coil	Resistance	Primary coil	0.6-0.9 Ω	--
		Secondary coil	5.6-6.9k Ω	--
	Air gap		0.2-0.6mm	--

1-3-6 R280

Parts	Item	Standard	Service limit
Engine	Maximum speed (No load)	3750-3850rpm	--
	Cylinder compression	□1.1Mpa (1400rpm)	--
Cylinder head	Sleeve I.D.	78.0-78.015mm	78.17mm
Cylinder head	Warpage	--	0.10mm
Piston	Skirt O.D.	77.96-76.98mm	76.85mm
	Piston-to-cylinder clearance	0.015-0.055mm	0.12mm
	Piston pin bore I.D.	18.202-18.208mm	18.242mm
	Piston pin O.D.	18.192-18.198mm	18.15mm
	Piston pin-to-piston pin bore clearance	0.004-0.016mm	0.08mm
Piston rings	Ring side clearance: first/ second	0.02-0.06mm	0.15mm
		Oil	--
	Ring end gap: first/second	0.20-0.40mm	1.0mm
		Oil	0.2-0.7mm
	Ring width: first/second	3.4-3.6mm	1.37mm
		Oil	2.75-3.15mm
Connecting	Small end I.D	18.211-18.222mm	18.27mm

rod	Big end I.D		33.225-33.239mm	33.27mm
	Big end oil clearance		0.013-0.03mm	0.12mm
	Big end side clearance		0.25-0.65mm	1.0mm
Crankshaft	Crankshaft pin O.D		33.175-33.185mm	33.12mm
Valves	Valve clearance	IN	0.10-0.15mm	--
		EX	0.15-0.20mm	--
	Stem O.D.	IN	6.575-6.59mm	6.44mm
		EX	6.535-6.55mm	6.4mm
	Guide I.D.	IN/EX	6.6-6.615mm	6.66mm
	Stem clearance	IN	0.01-0.04mm	0.10mm
		EX	0.05-0.08mm	0.12mm
	Seat width		0.8-1.0mm	2.0mm
	Spring free length		38.5-39.5mm	37.5mm
camshaft	Cam height	IN	6.045mm	5.95mm
		EX	5.766mm	5.65mm
	Journal O.D		16.166-16.184mm	16.12mm
Crankcase cover	Camshaft holder I.D		16.2-16.218mm	16.248mm
Carburetor	Main jet		Φ2	--
	Float height		1-3mm	--
	Pilot screw opening		2-7/8 circle	--
Spark plug	Gap		0.7-0.8mm	--
Spark plug cap	Resistance		9.5-10.5kΩ	--
Ignition coil	Resistance	Primary coil	0.6-0.9Ω	--
		Secondary coil	5.6-6.9kΩ	--
	Air gap		0.3-0.5mm	--

1-3-7 R300

Parts	Item	Standard	Service limit
Engine	Maximum speed (No load)	3750-3850rpm	--
	Cylinder compression	□1.1Mpa (1400rpm)	--
Cylinder head	Sleeve I.D.	80.0-80.015mm	80.17mm
Cylinder head	Warpage	--	0.10mm

Piston	Skirt O.D.		79.975-79.985mm	79.85mm
	Piston-to-cylinder clearance		0.015-0.04mm	0.12mm
	Piston pin bore I.D.		15.002-15.008mm	15.242mm
	Piston pin O.D.		14.992-14.998mm	14.95mm
	Piston pin-to-piston pin bore clearance		0.004-0.016mm	0.08mm
Piston rings	Ring side clearance: first/ second		0.025-0.06mm	0.15mm
	Oil		--	--
	Ring end gap: first/second		0.20-0.40mm	1.0mm
	Oil		0.30-0.50mm	1.0mm
	Ring width: first/second		0.2-0.7mm	1.0mm
	Oil		2.8-3.0mm	1.37mm
Connecting rod	Small end I.D		15.011-15.022mm	15.27mm
	Big end I.D		33.025-33.039mm	33.07mm
	Big end oil clearance		0.013-0.03mm	0.12mm
	Big end side clearance		0.25-0.65mm	1.0mm
Crankshaft	Crankshaft pin O.D		32.975-32.985mm	32.92mm
Valves	Valve clearance	IN	0.10-0.15mm	--
		EX	0.15-0.20mm	--
	Stem O.D.	IN	5.468-5.48mm	5.34mm
		EX	5.43-5.445mm	5.3mm
	Guide I.D.	IN/EX	5.485-5.5mm	5.56mm
	Stem clearance	IN	0.005-0.032mm	0.10mm
		EX	0.04-0.07mm	0.12mm
	Seat width		0.8-1.0mm	2.0mm
Spring free length		38.5-39.5mm	37.5mm	
camshaft	Cam height	IN	6.045mm	5.95mm
		EX	5.766mm	5.65mm
	Journal O.D		16.166-16.184mm	16.12mm
Crankcase cover	Camshaft holder I.D		16.2-16.218mm	16.248mm
Carburetor	Main jet		Φ2	--
	Float height		1-3mm	--
	Pilot screw opening		2-7/8 circle	--
Spark plug	Gap		0.7-0.8mm	--

Spark plug cap	Resistance	9.5-10.5kΩ	--
Ignition coil	Resistance	Primary coil	0.6-0.9Ω
		Secondary coil	5.6-6.9kΩ
	Air gap		0.3-0.5mm

1-3-8 R390

Parts	Item	Standard	Service limit
Engine	Maximum speed (No load)	3750-3810rpm	--
	Cylinder compression	≧ 1.37Mpa (1400rpm)	--
Cylinder head	Sleeve I.D	88-88.017mm	88.17mm
Cylinder head	Warpage	--	0.10mm
Piston	Skirt O.D.	87.965-87.985mm	87.85mm
	Piston-to-cylinder clearance	0.015-0.052mm	0.12mm
	Piston pin bore I.D.	20.002-20.008mm	20.042mm
	Piston pin O.D	19.994-20mm	19.95mm
	Piston pin-to-piston pin bore clearance	0.002-0.014mm	0.08mm
Piston rings	Ring side clearance: first/ second	0.015-0.045mm	0.15mm
	Oil	--	--
	Ring end gap: first/second	0.2-0.4mm	1.0mm
	Oil	0.2-0.7mm	1.0mm
	Ring width: first/second	1.5mm	1.37mm
	Oil	2.0mm	2.0mm
Connecting rod	Small end I.D	20.005-20.02mm	20.07mm
	Big end I.D	36.025-36.039mm	36.07mm
	Big end oil clearance	0.040-0.066mm	0.12mm
	Big end side clearance	0.1-0.7mm	1.0mm
Crankshaft	Crankshaft pin O.D	35.975-35.985mm	35.92mm
Valves	Valve clearance	IN	0.15 ± 0.02mm
		EX	0.20 ± 0.02mm
	Stem O.D	IN	6.575-6.59mm
		EX	6.535-6.55mm
	Guide I.D	IN/EX	6.6-6.612mm
	Stem clearance	IN	0.01-0.037mm

	EX	0.05-0.077mm	0.13mm
	Seat width	1.1mm	2.0mm
	Spring free length	39.0mm	37.5mm
camshaft	Cam height	IN 33.6-33.8mm	33.58mm
	Journal O.D	EX 32.90-33.10mm 15.966-15.984mm	32.88mm 15.92mm
Crankcase cover	Camshaft holder I.D	16.0mm	16.048mm
Carburetor	Main jet	0.92	--
	Float height	13.2mm	--
	Pilot screw opening	1-7/8 turns	--
Spark plug	Gap	0.7-0.8mm	--
Spark plug cap	Resistance	7.5-12.5kΩ	--
Ignition coil	Resistance	Primary coil 0.6-0.9Ω	--
		Secondary coil 5.6-6.9kΩ	--
	Air gap	0.2-0.6mm	--

1-3-9 R420

Parts	Item	Standard	Service limit
Engine	Maximum speed (No load)	3750-3850rpm	--
	Cylinder compression	□1.2Mpa (1400rpm)	--
Cylinder head	Sleeve I.D	90-90.015mm	90.17mm
Cylinder head	Warpage	--	0.10mm
Piston	Skirt O.D.	89.96-89.97 mm	89.85mm
	Piston-to-cylinder clearance	0.03-0.055 mm	0.27mm
	Piston pin bore I.D.	20.002-20.008 mm	20.042mm
	Piston pin O.D	19.992-19.998 mm	19.95mm
	Piston pin-to-piston pin bore clearance	0.004-0.016 mm	0.08mm
Piston rings	Ring side clearance: first/ second	0.02-0.06mm	0.15mm
	Oil	--	--
	Ring end gap: first/second	0.2-0.4 mm	1.0mm
	Oil	0.2-0.7 mm	1.0mm

	Ring width:	first/second Oil	3.7-3.9 mm 2.95-3.15 mm	1.37mm 2.0mm
Connecting rod	Small end I.D		20.011-20.022 mm	20.07mm
	Big end I.D		36.025-30.039 mm	36.07mm
	Big end oil clearance		0.25-0.65 mm	0.12mm
	Big end side clearance		0.013-0.03 mm	1.0mm
Crankshaft	Crankshaft pin O.D		35.975-35.985 mm	35.92mm
Valves	Valve clearance	IN	0.013-0.017 mm	--
		EX	0.018-0.022 mm	--
	Stem O.D	IN	6.565-6.580 mm	6.44mm
		EX	6.545-6.560 mm	6.4mm
	Guide I.D	IN/EX	6.6-6.615 mm	6.66mm
	Stem clearance	IN	0.015-0.055mm	0.11mm
		EX	0.015-0.055mm	0.13mm
	Seat width		0.65-0.95	2.0mm
	Spring free length		38.8-39.2mm	37.5mm
camshaft	Cam height	IN	6.59 mm	33.58mm
		EX	6.07 mm	32.88mm
	Journal O.D		15.966-15.984 mm	15.92mm
Crankcase cover	Camshaft holder I.D		16-16.018	16.048mm
Carburetor	Main jet		Φ2	--
	Float height		1-3	--
	Pilot screw opening		--	--
Spark plug	Gap		0.7-0.8mm	--
Spark plug cap	Resistance		9.5-10.5kΩ	--
Ignition coil	Resistance	Primary coil	0.6-0.9Ω	--
		Secondary coil	5.6-6.9kΩ	--
	Air gap		0.3-0.5mm	--

1-3-10 R440

Parts	Item	Standard	Service limit
Engine	Maximum speed (No load)	3750-3850rpm	--
	Cylinder compression	≧ 1.2Mpa (1400rpm)	--
Cylinder	Sleeve I.D	92-92.015mm	92.17mm

head				
Cylinder head	Warpage	--	0.10mm	
Piston	Skirt O.D.	91.96-91.97 mm	91.85mm	
	Piston-to-cylinder clearance	0.03-0.055 mm	0.27mm	
	Piston pin bore I.D.	20.002-20.008 mm	20.042mm	
	Piston pin O.D	19.992-19.997 mm	19.95mm	
	Piston pin-to-piston pin bore clearance	0.004-0.016 mm	0.08mm	
Piston rings	Ring side clearance: first/ second	0.02-0.06mm	0.15mm	
	Oil	--	--	
	Ring end gap: first/second	0.25-0.4 mm	1.0mm	
	Oil	0.2-0.7 mm	1.0mm	
	Ring width: first/second	3.2-3.4 mm	1.37mm	
	Oil	2.42-2.82 mm	2.0mm	
Connecting rod	Small end I.D	20.011-20.022 mm	20.07mm	
	Big end I.D	36.025-36.039 mm	36.07mm	
	Big end oil clearance	0.25-0.65 mm	0.12mm	
	Big end side clearance	0.013-0.03 mm	1.0mm	
Crankshaft	Crankshaft pin O.D	35.975-35.985 mm	35.92mm	
Valves	Valve clearance	IN EX	0.013-0.017 mm --	
	Stem O.D	IN EX	0.018-0.022 mm 5.475-5.490 mm	
	Guide I.D	IN/EX	5.435-5.45 mm	
	Stem clearance	IN EX	5.5-5.515 mm 0.015-0.055mm	
	Seat width		0.015-0.055mm	
	Spring free length		0.65-0.95mm	
				2.0mm
				37.5mm
camshaft	Cam height	IN EX	32.742-33.142 mm 31.609-32.009 mm	
	Journal O.D		15.966-15.984 mm	
Crankcase cover	Camshaft holder I.D	16-16.018	16.048mm	
Carburetor	Main jet	Φ2.4	--	
	Float height	1-3	--	

	Pilot screw opening	--	--
Spark plug	Gap	0.7-0.8mm	--
Spark plug cap	Resistance	9.5-10.5k Ω	--
Ignition coil	Resistance	Primary coil	0.6-0.9 Ω
		Secondary coil	5.6-6.9k Ω
	Air gap		0.3-0.5mm

2. DIMENSIONS AND TORQUE

2-1 ENGINE DIMENSIONS

2-1-1 R100

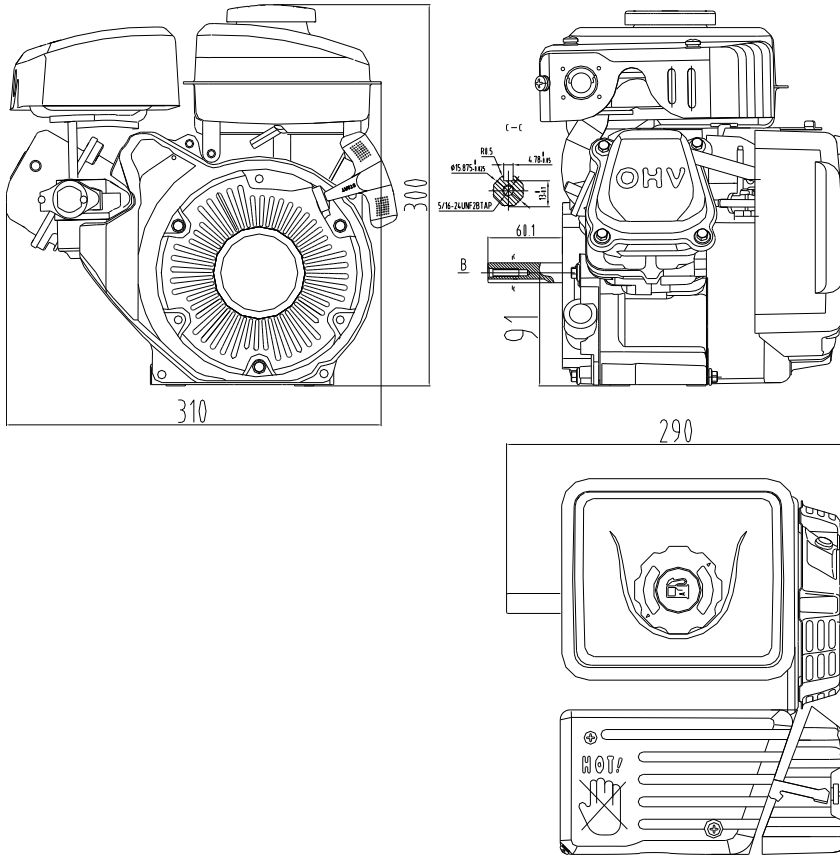

2-1-2 R160/R180/R200/R210/R225

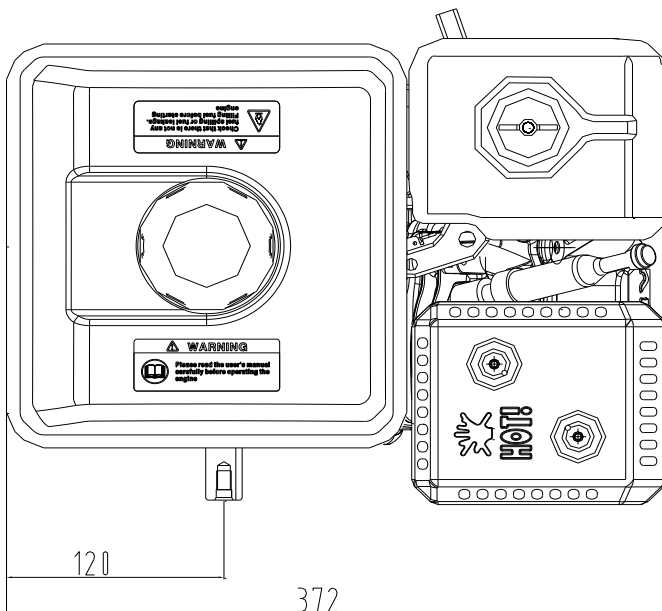

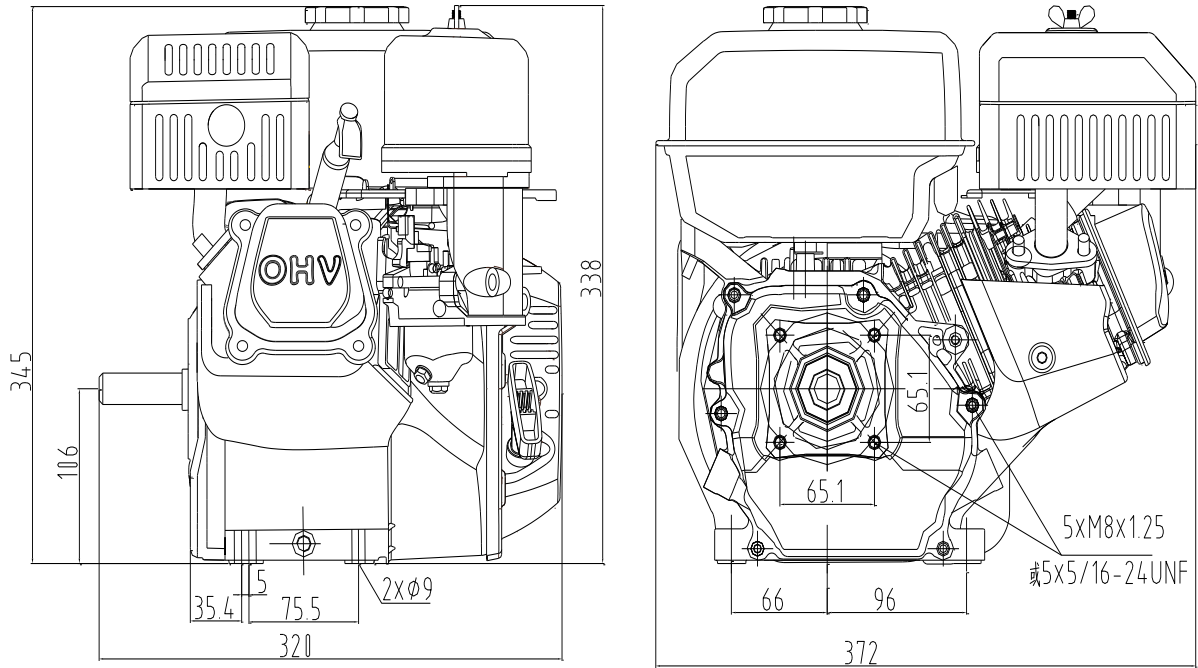

2-1-3 R270/R280/R300

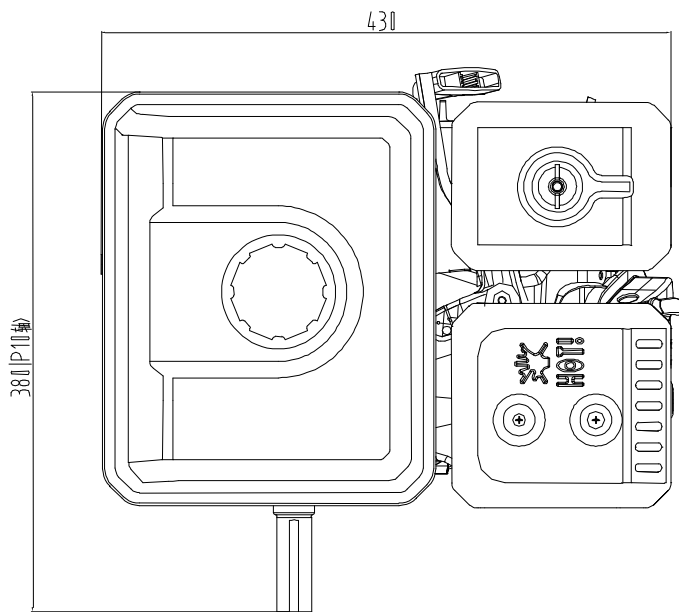

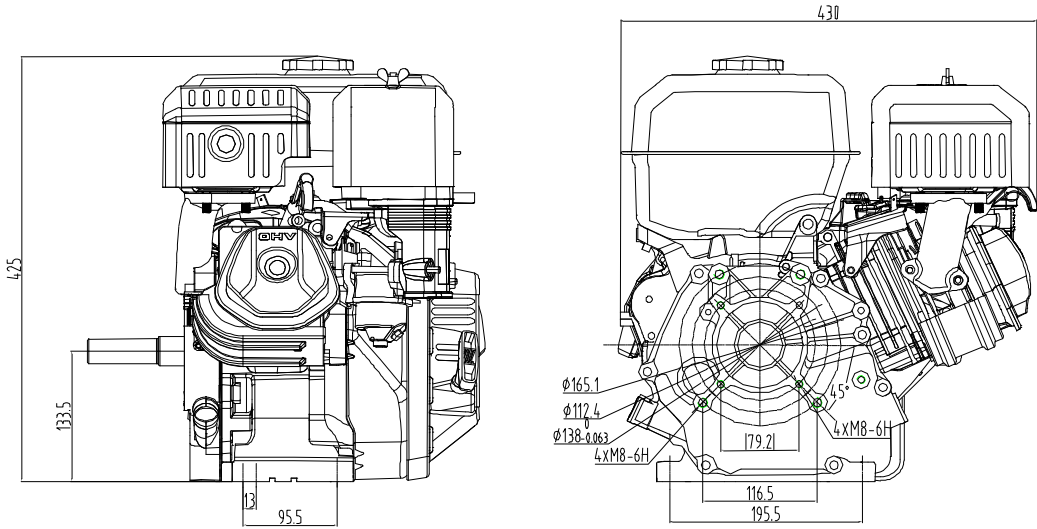

2-1-4 R390/R420/R440

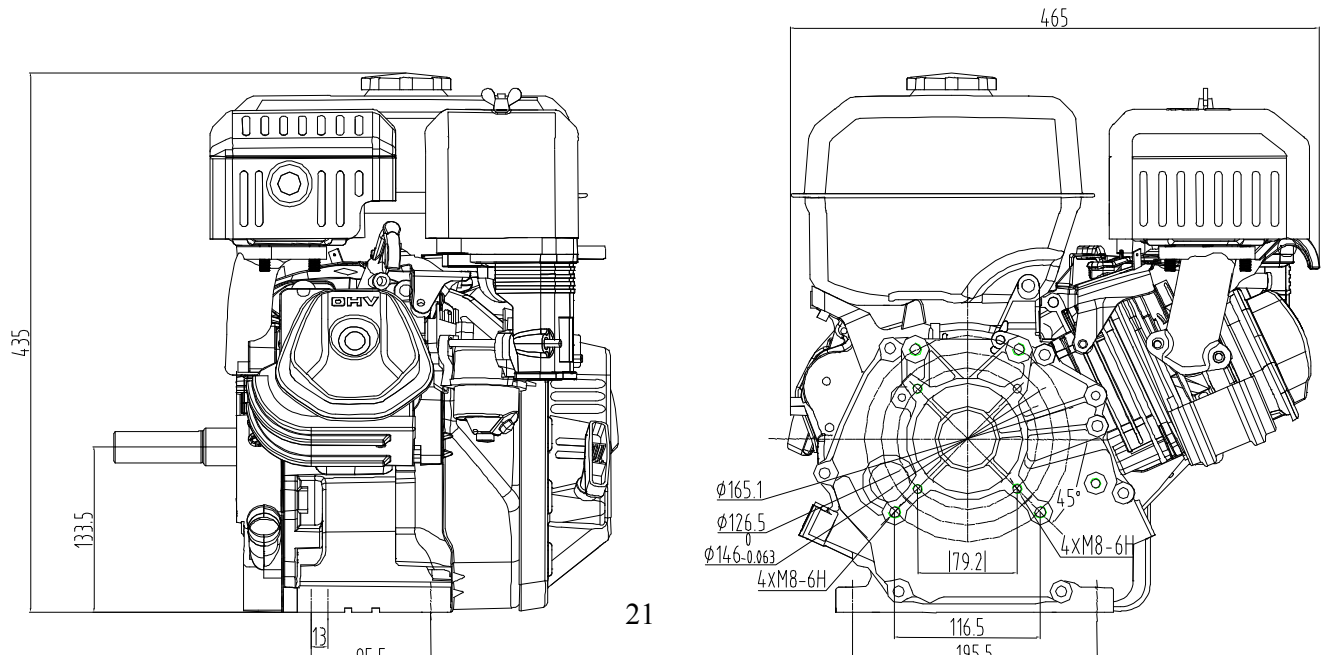
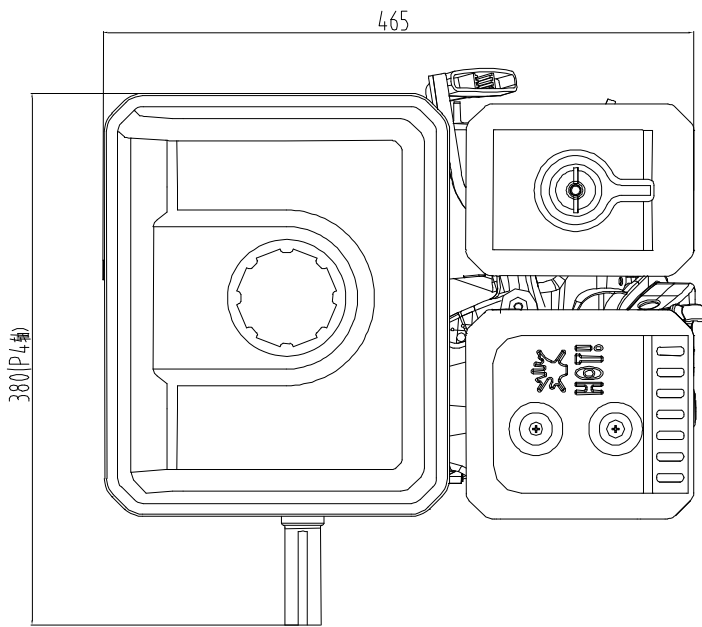

2-2 TORQUE VALUES

2-2-1 torque values

Ser. no.	Part	MODEL	Part description and specifications	Torque value	Connecting components
1	Oil drain plug	R100 R160-R225 R270-R440	M10×1.5×15 8.8-A M10×1.5×15 8.8-A M12×1.5×18 8.8-A	22±2	Oil drain plug-flat washer-crankcase
2	Oil sensor	R100 R160-R225 R270-R440	M6×14 8.8-A M6×14 8.8-A M6×16 8.8-A	8±2	Oil sensor-crankcase
		R100 R160-R225 R270-R440	M10×1.5 8-A	7±1	
3	Connecting rod	R100 R160-R210 R225 R270-R420 R440	M6×25 10.9-A M7×32 10.9-A M5×32 10.9-A M8×35 10.9-A M8×35 10.9-A	12±1 13±1 8±1 15±1 18±1	Connecting rod cover-crankcase-connecting rod
		R100 R160-R225	M6×25 8.8-A M8×32 8.8-A	11±2 28±2	Crankcase cover-crankcase gasket-crankcase
		R100 R160-R225 R270-R440	M12×1.25 8-A M14×1.5 8-A M16×1.5 8-A	55±4 75±4 95±4	Starter pulley-impeller-flywheel subassembly-crankcase assy.
		R100 R160-R225 R270-R440	M6×20 8.8-A M6×25 8.8-A M6×28 8.8-A	11±1	Ignition coil-crankcase
		R100 R160-R225 R270-R440	M6×20 10.9-A M8×32 10.9-A M8×35 10.9-A	32±2 32±2 42±2	Cylinder head subassembly- gasket-crankcase
8	Rocker shaft bolt	R100 R160-R225 R270-R440	M8×1.25 8.8-A M8×1.25 8.8-A M8×1.25 8.8-A	24±2	Rocker shaft bolt- cylinder head subassembly
		R100 R160-R225	M6×12 8.8-A M6×12 8.8-A	10±1	Cylinder head cover subassembly - cylinder

	subassembly	R270-R440	--		head subassembly
10	Spark plug	R100-R440	M14×1.25	28±2	Spark plug-cylinder head subassembly
11	Cylinder shroud	R100 R160-R210 R270-R4440	M6×10 8.8-A M6×8 8.8-A M6×12 8.8-A	10±2	Cylinder shroud-cylinder head subassembly
12	Lower shield	R100 R160-R225 R270-R440	-- M6×16 8.8-A --	10±2	Lower shield- crankcase
13	Oil protector	R100 R160-R225 R270-R440	-- M6×12 8.8-A M6×12 8.8-A	8±2	Oil protector - crankcase
14	Shroud	R100 R160-R225 R270-R440	M6×12 8.8-A M6×12 8.8-A M6×12 8.8-A	10±2	Shroud- crankcase
15	Recoil starter	R100 R160-R225 R270-R440	M6×8 8.8-A M6×8 8.8-A M6×8 8.8-A	10±2	Recoil starter- shroud
16	Air cleaner	R100-R440	M6 8-A	10±2	Air cleaner- gasket- carburetor
17	Throttle control subassembly	R100 R160-R225 R270-R440	M6×8 8.8-A M6×12 8.8-A M6×12 8.8-A	10±2	Throttle control subassembly- crankcase - cylinder head subassembly
18	Governor support subassembly	R100-R400	M6 8-A	8±1	Governor support subassembly - Governor arm- governor support subassembly
19	Charging coil subassembly	R100 R160-R225 R270-R440	-- M6×28 8.8-A M6×32 8.8-A	10±2	Charging coil subassembly - crankcase
20	Charging coil clamp	R100 R160-R225 R270-R440	-- M6×10 8.8-A M6×10 8.8-A	10±2	Charging coil clamp - crankcase
21	Starter motor subassembly	R100 R160-R225	-- M6×35 8.8-A	11±1	Starter motor subassembly - crankcase

		R270-R440	M6×30 8.8-A		
--	--	-----------	-------------	--	--

2-3 STANDARD TORQUE VALUES

Item	Specifications	Torque valve	
		N·m	Kg·m
Standard torque	5mm bolt, nut	5.5	0.55
	6mm bolt, nut	10	1.0
	8mm bolt, nut	21	2.4
	10mm bolt, nut	37.5	3.75
	12mm bolt, nut	55	5.5

3. MAINTENANCE

3-1. MAINTENANCE SCHEDULE

Good maintenance is essential for safe, economical, and trouble-free operation. It will also help reduce air pollution.

⚠ WARNING Exhaust gas contains poisonous carbon monoxide. Shut off the engine before performing any maintenance. If the engine must be running during maintenance, make sure the area is well ventilated.

Periodic maintenance and adjustment are necessary for keeping the generator in a good operating condition. Perform the service and inspection at the intervals shown in the Maintenance Schedule below:

Time option	Each use	First month or 20 Hrs. (3)	Every 3 months or 50 Hrs. (3)	Every 6 months or 100 Hrs. (3)	Every year or 300 Hrs. (3)
Oil Check	○				
Oil Replace		○		○	
Air cleaner element Check	○				
Air cleaner element Clean			○ □		
Fuel strainer Clean				○	
Spark plug Clean Adjust				○	
Valve gap Check Adjust					○
Fuel tank, fuel element Clean					○
Fuel tube Check	Every 2 years (2)				
Replace	Every 4 years (4)				

□ Clean the air cleaner once every 10 hours or once every day when engine is used in dusty areas.

3-2 ENGINE OIL

• Oil change

- 1) Dismount the oil filler cap and oil drain bolt to drain dirty oil.
- 2) Tighten the oil drain plug
See 2-2-1 Maintenance Standard
- 3) Add the clean oil from the filler neck.

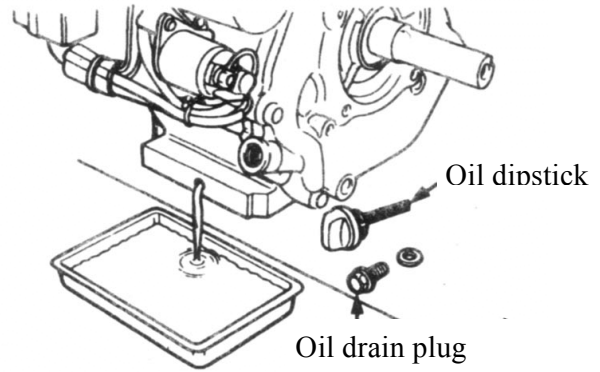

R100 Oil capacity	0.35L
R160/R180/R200/R210/R225 Oil capacity	0.6L
R270/R300/R390/R420 Oil capacity	0.6L

Recommended oil	<p>General oil: SAE15W-40 SJ class or equivalent API classified SJ class SAE10W-30 oil.</p> <p><input type="checkbox"/> In a low temperature range (below 10°C), use oil with the grade higher than SAE10W-30 °</p> <p><input type="checkbox"/> In a cold environment (temperature is below -15°C), use SAE5W-30, or equivalent API classified SJ class SAE5W-30 oil.</p>
-----------------	---

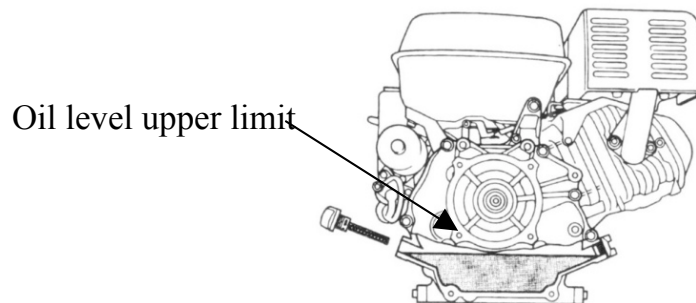

- 4) After filling, check oil level. If the oil is insufficient, add the oil to the upper limit.

CAUTION: Run with insufficient engine oil may damage the engine severely.

3-3 AIR CLEANER

Dual element type

- 1) Remove the nut, air cleaner cover and wing nut. Remove polyurethane and paper elements.
- 2) Clean polyurethane with detergent, then, blow it dry with compressed air or squeeze it dry. Dip the element in clean oil, then, forcefully squeeze it dry and install it back.
- 3) Tap the element lightly several times on a hard surface to remove excess dirt or blow compressed air lightly from the inside out. If it is dirty, replace it in time.

CAUTION: Polyurethane element containing too much oil will jam the strainer holes.

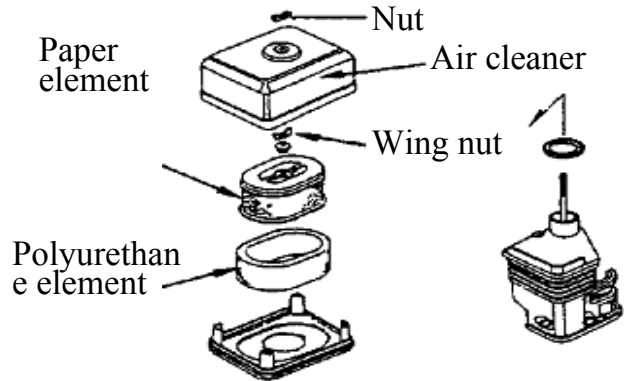

Oil bath type

- 1) Clean the air cleaner case with cleaning oil and dry it.
- 2) Add the clean oil to specified level and install the air cleaner case back.
- 3) Clean the polyurethane element with cleaning oil, then blow with compressed air or squeeze. Dip the element in clean oil, then, forcefully squeeze and install it back.

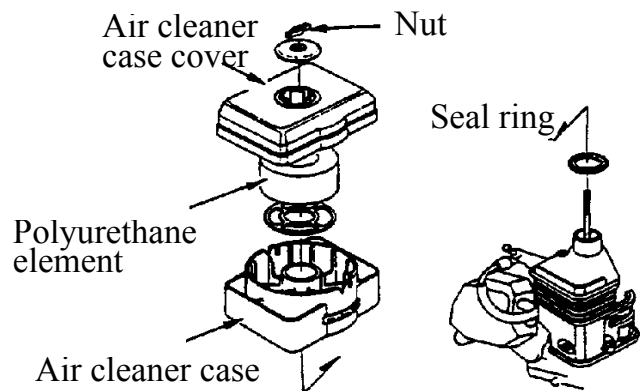

3-4 CLEANING OF THE FUEL FILTER

Caution

- Don't smoke when washing.
- Be sure there is no fuel leakage after tightening.

Turn the fuel cock to OFF position and tighten filter cup. Torque : 7N.m

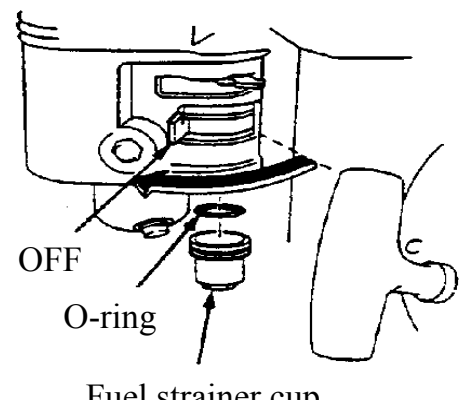

3-5 SPARK PLUG CLEANING AND ADJUSTING

- 1) Remove carbon or other deposits with a stiff wire brush. Check gasket for damage.
- 2) Measure plug gap between center electrode and side electrode with a spark plug feeler. If necessary, adjust the gap by bending the side electrode.

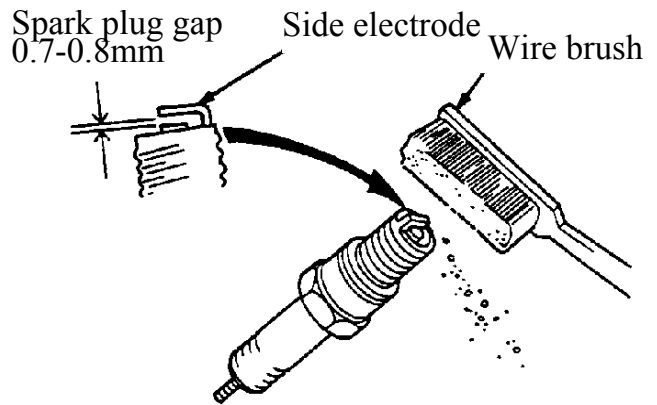

Spark plug gap	0.7 - 0.8 mm
----------------	--------------

Standard spark plug	BP6ES (NGK)
	F7TC
	BPR6ES (NGK)with anti-wave interference ability
	F7RTCwith anti-wave interference ability

3-6 VALVE CLEARANCE ADJUSTMENT

CAUTION :

Valve clearance adjustment must be performed with the engine cold.

- 1) Remove the cylinder head cover bolt, head cover and gasket.

CAUTION :

Be careful to avoid oil leaking when removing cylinder head cover.

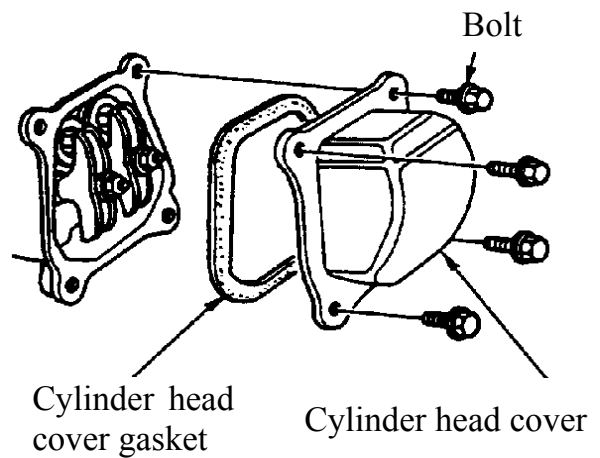

- 2) Set the piston at top dead center of the compression stroke.
- 3) Insert a feeler gauge between the rocker arm

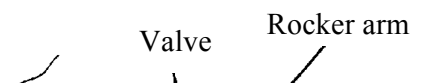

and valve to measure valve clearance.

Valve clearance	IN : 0.15 ± 0.02 mm EX : 0.20 ± 0.02 mm
-----------------	--

4) If adjustment is necessary, proceed as follows:

- a · Hold the rocker arm pivot and loosen the valve lock nut
- b · Turn the rocker arm pivot to obtain the specified clearance.
- c · Fix the rocker arm pivot with a spanner, then tighten the lock nut.
- d · Recheck valve clearance after tightening the valve lock nut.

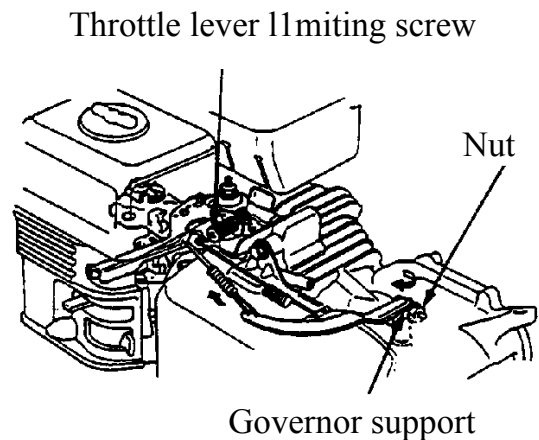

3-7 GOVERNOR

- 1) Remove the fuel tank.
- 2) Loosen the nut on the governor arm. Check the throttle to ensure it is fully open. (turn to left to extreme position) .
- 3) Turn the governor support right to extreme position(governor fully close position). Tighten the bolt and nut.
- 4) Check the governor support and throttle to ensure free moving.
- 5) Assembling fuel tank.

Start the engine, rotate the throttle lever limiting screw to adjust the maximum speed.

Maximum	3780±50rpm
---------	------------

4. DISASSEMBLING AND SERVICING

4-1 TROUBLESHOOTING

4-1-1 Hard starting

TROUBLE			CAUSE		REMEDY
Normal cylinder compression	Normal spark plug spark	Something wrong with the fuel system.	Fuel supply is not smooth or there is no fuel supply.	There is no enough fuel in fuel tank and fuel cock is closed.	Add fuel, open fuel cock.
				Air vent in the fuel tank cover is clogged	Unclog air vent.
				Improper or clogged main jet.	Readjust or clean, blow to get through.
				Needle valve is not closed properly or start hole is clogged.	Dismantle needle valve and repair, clean, blow to get through.
				Float is damaged or sticking.	Repair float
			Fuel supply is normal.	Fuel is too filthy or deteriorated	Replace
				There is water in fuel.	Replace
				Too much fuel in engine	Drain extra fuel, dry up spark plug electrodes.
				Wrong fuel grade	Select proper fuel grade corresponding with the requirements.

	al fuel supply system.	Normal high-tension cord spark.	Spark plug is in poor conditions	Too much carbon deposit and dirt around electrodes.	Clear away.	
				Electrodes are burned badly or insulators are damaged.	Replace spark plug.	
		High-tension cord with no spark	Normal spark plug	Improper electrode gap.	Adjust to proper value.	
				High-tension cord is damaged.	Replace	
	Ignition coil is damaged.			Replace		
	Magneto loses magnetism.			Replace		
					Abnormal gap between the ignition coil and flywheel.	Adjust gap

TROUBLE		CAUSE		REMEDY
Abnormal cylinder compression	Normal fuel supply system	Normal ignition system	Piston ring is worn too much or even over its service limit	Replace
			Piston ring is broken.	Replace
			Piston ring is sticking.	Clear up carbon fouling.
			Spark plug is not installed tightly or is installed without a gasket.	Tighten with a gasket in.
			Air leakage between cylinder block and cylinder head.	Check cylinder gasket, and the flatness of the surface by which cylinder block contacting with cylinder head
				Tighten cylinder head cover bolts in stipulated order to stipulated torque value.
		Air leakage in the valves	Check valve clearance and tightness, repair if necessary.	

If engine still can't start, take the engine to our authorized dealer to repair it.

● Spark plug testing

WARNING:

- When testing the spark plug, never hold the high-tension cord of the spark plug with wet hand.
- Make sure there is no spilled fuel outside the engine and that the spark plug isn't dipped with fuel.
- To prevent fire, keep sparks far away from the spark plug mounting hole.



- Turn the fuel cock to “OFF” position, and drain the gasoline of the carburetor.
- Remove the spark plug and spark plug cap.
- Pull the recoil start handle to drive off the gas out of the cylinder.
- Install the spark plug cap.
- Put the control lever to “low” position.
- Put negative pole (thread) of the spark plug through cylinder cover to connect to ground and pull the recoil start handle to observe the spark.

4-1-2 Engine lacks power

TROUBLE	CAUSE		REMEDY
When increasing throttle opening, speed increases slowly or even decreases and stops running	Ignition system	Air in fuel line or fuel line is clogged	Drain air or unclog fuel line
		Main jet is not adjusted properly	Readjust
		In carburetor, needle valve and main jet are clogged.	Clean and blow to get through
	Fuel supply system	Fuel cock is clogged.	Clean, replace damaged part
		Too much carbon deposit in combusting chamber.	Clear away
		Air cleaner is clogged.	Clean air cleaner filter element
		Intake pipe is leaking	Repair or replace
	Poor compression	Intake pipe is leaking	Repair or replace
		Piston, cylinder or piston ring is worn	Replace the worn part
		Air leakage from the surface along which cylinder block contacts with cylinder head.	Replace cylinder gasket
Too big or too small valve clearance.		Readjust	

• Compression pressure check



Drain the oil of the fuel tank.

Drain the gasoline by loosening the fuel drain plug of the carburetor.

Remove the spark plug cap and spark plug and install the cylinder pressure meter.

Forcibly pull the recoil starter several times and measure compression force ($\geq 0.4\text{MPa}$)

4-1-3 Speed is unstable

TROUBLE	CAUSE	REMEDY
Knocking sound	Piston, cylinder or piston ring is worn excessively.	Replace the worn part
	Piston pin and piston pin hole are worn excessively.	Replace piston or piston pin
	Connecting rod small head is worn excessively.	Replace connecting rod
	Roller bearing for crankshaft main journal is worn.	Replace roller bearing
Abnormal combustion	Engine is too hot	Shoot trouble
	Too much carbon deposit in combustion chamber	Clear away
	Improper gasoline grade or low gasoline quality	Replace with qualified gasoline
Lack of spark	There is water in float chamber	Clean
	Improper clearance between spark plug and electrodes	Adjust
	Something wrong with induced coil, and so on	Check and replace damaged parts

4-1-4 Motor is unable to start

TROUBLE	CAUSE	REMEDY
1. Check the battery connection	Improper connection	Correct the connection
2. Check battery	Wrong gasoline engine, or battery is charged insufficiently, battery is stored long without being used, and pole plate's sulphation is eroded.	Check or replace rectification circuit, charge the battery with a special charger or replace the battery.
3. Starter motor running is abnormal	Motor and relay are in trouble, connection is loose, falling off and switch is damaged.	Check and eliminate starting appliance circuit trouble or replace damaged part.

4-1-5 Exhaust gas color is abnormal

TROUBLE	CAUSE	REMEDY
Black smoke	Piston, cylinder or piston ring is worn excessively.	Replace the worn part
	Too much carbon deposit in combustion chamber	Clear away
	Too much carbon deposit in combustion chamber	Clear away
	Improper gasoline grade or low gasoline quality	Replace with qualified gasoline
	Air cleaner is clogged.	Clean air cleaner filter element

4-1-6 Unable to ignite

TROUBLE	CAUSE		REMEDY
Unable to ignite	Fuel supply system	Fuel has run out	Add fuel
		Carburetor is clogged	Check fuel line and unclog it
		Float is leaking	Repair
		Needle valve is stuck	Dismantle float chamber and eliminate the sticking
	Ignition system	Spark plug is punctured, or short-circuited by carbon deposit	Replace spark plug

		Side electrode of spark plug has dropped out	Replace spark plug
		High-tension cord has dropped out	Weld it on
		Ignition coil is punctured or short-circuited	Replace ignition coil
		Stop engine wire is located on engine body	Find out the meeting position, separate them and insulate
	Others	Cylinder is seriously scored and valves have dropped out	Repair or replace damaged parts

4-1-7 Oil alert system malfunction

Check the oil alert system with the following method:

- 1) Disconnect yellow lead of the engine and connect the engine to ground when the engine is running. Be sure the alert lamp lights up, and the engine stops.
- 2) Disconnect oil level switch lead under the specified condition with the engine stopped, and check the continuity of the yellow and green leads, uncontinuity between yellow and green leads is normal.
- 3) Disconnect oil level switch lead after draining oil out with the engine stopped, and check the continuity of the yellow and green leads, continuity between yellow and green leads is normal.

4)

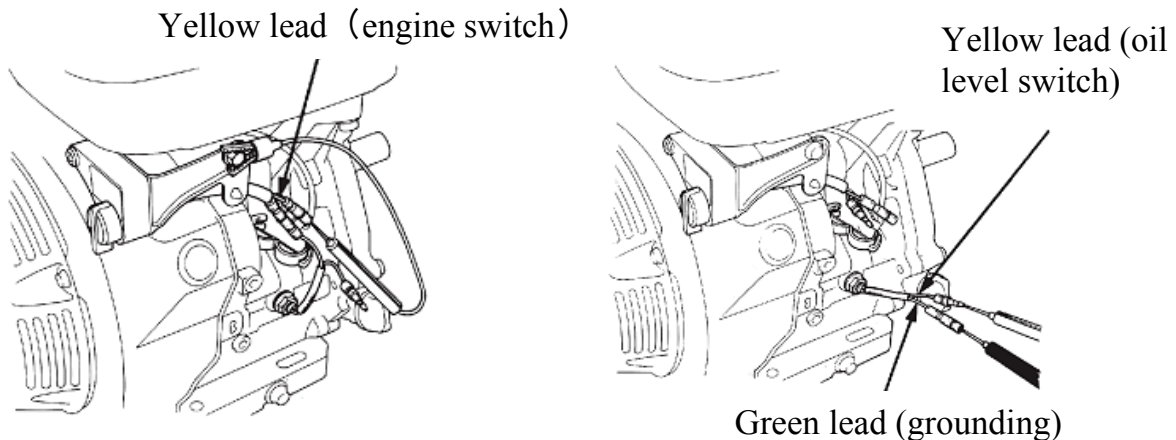

4-1-8 GASOLINE ENGINE IS OVERERHEATED

TROUBLE	CAUSE	REMEDY
---------	-------	--------

Gasoline engine is overheated	Oil insufficient or wrong oil/gasoline ratio	Add engine oil
	Exhaust pipe is blocked	Clean exhaust pipe
	Shroud is leaking	Repair damaged part
	Cooling fins are blocked by foreign matter	Clear cooling fins
	Cooling fan is loose and malfunctioning	Reinstall it well
	Connecting rod deformation to make piston and cylinder bushing side wear	Replace connecting rod
	Cylinder, piston or piston ring is worn, causing hunting between cylinder and crankcase	Replace the worn parts
	Improper adjustment of engine governor cause high speed.	Readjust engine governor
	Crankshaft main bearing is burnt out	Replace main bearing

4-2 PREPARATION OF SERVICING

4-2-1 Safety precautions

WARNING:

Indicate the possibility of invalid warranty and personal injury or equipment damage if instructions are not followed.

Please pay special attention to the following:

1. Strictly set the engine according to the regulated power on the nameplate. Do not overload, overrun the engine or run it with a low load and at low speed for a long time.
2. Use prescribed grade of gas and diesel. The fuel should be fully deposited and filtered before being used. Keep the fuel filler clean, change the fuel periodically.
3. Periodically check the installation, connection and the degree of tightness of the fixed bolt. Tighten it if necessary.
4. Periodically clean the element of the air cleaner, change it when necessary.
5. The engine is air-cooled, so clean the radiator, wind cover and fan in time in order to ensure the engine can cool normally.
6. The operator should be familiar with the working principle and structure of the gasoline engine, know how to make an emergency stop and the operation of all controlling parts. Any one without training is forbidden to operate the engine. Keep periodical maintenance. Solve problems in time. Do not run the engine when it has malfunction.
7. Run the engine in a well-ventilated place, keep it at least one meter away from building

walls or other equipment, keep away from inflammables such as gasoline, matches and so on to avoid possibility of fire.

8. Refuel in a well-ventilated area with the engine stopped, and in places refueling or storing gasoline, no smoking and any flames or sparks.
9. Refuel the fuel tank not too much so as to avoid fuel's spilling out. If there is spilled fuel around, be sure to clean it thoroughly before starting.
10. Do not run the engine in airtight or poorly ventilated places.
11. The exhaust muffler is very hot during running the engine even after the engine stops. Never touch it, or you may get burns. Transport or store the engine with it cooled down entirely.
12. Safety warning labels:
13. Please carefully read warning labels before operating. Our company will not assume any responsibility, for person injury, or equipment damage caused by disregarding warning labels.

(Applique labels are shown as follows)

1. Fuel label



2. Warning label



3. Displacement label



4. Trademark label



5. Throttle control label



6. Air cleaner maintenance label



7. Choke lever, fuel cock label



8. Oil grade label



9. Oil filling label

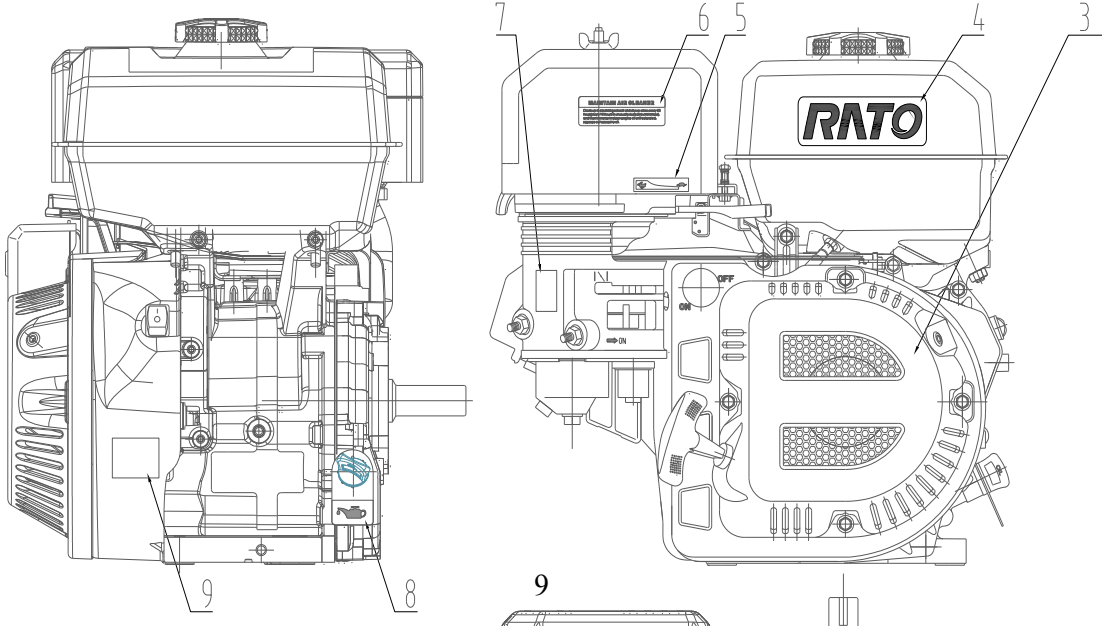

4-2-2 Special tools

Tool name	Application note
1. Float level gauge	Carburetor float level inspection.
2. Valve guide driver	Valve guide removal, installation.
3. Retainer assembler	Assembling ball bearing.
4. Assembler handle	Installing handle and bearing.
5. Inner retainer assembler	Assembling ball bearing and time gear.
6. Diamond lap 45 ⁰	Reconditioning valve seat surface.
7. Diamond lap 32 ⁰	Reconditioning valve seat surface.
8. Flywheel driver	Detaching flywheel.
9. Bearing extractor	Detaching flywheel.
10. Valve guide reamer	Fine reaming the guide inner hole.

4-3 DISASSEMBLING CHART

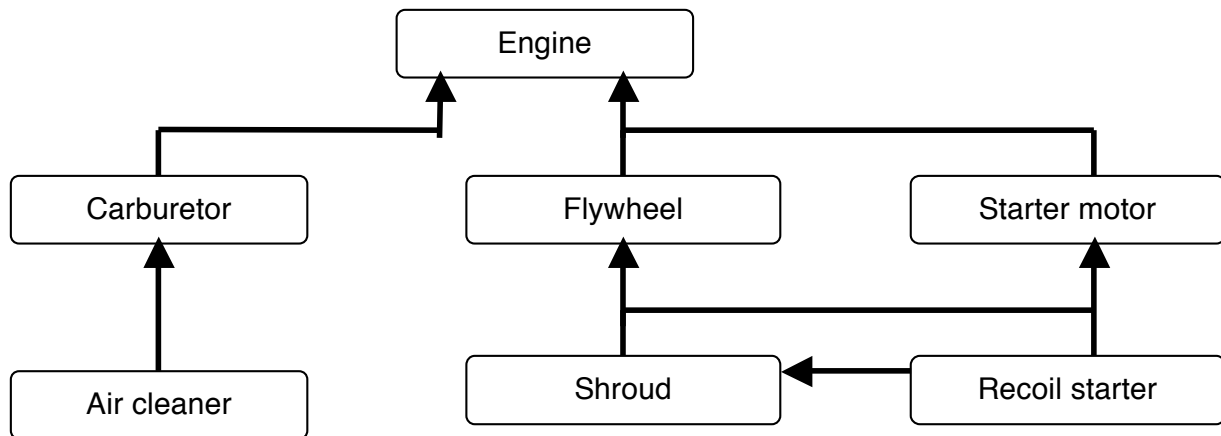

4-4 ENGINE

a · Disassembly, reassembly

Fan cover (only used for automatic starter)

Disassembly, reassembly:
Disassemble and reassemble with the recoil starter assembled.

Engine switch

Disassembly:
Detach the clip with a screwdriver

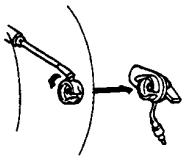

Black lead
(to ignition coil lead)

Black lead
(Connect to ignition coil lead)

**Engine switch
(Engine equipped with oil alert device)**

Fan cover (Recoil starter)

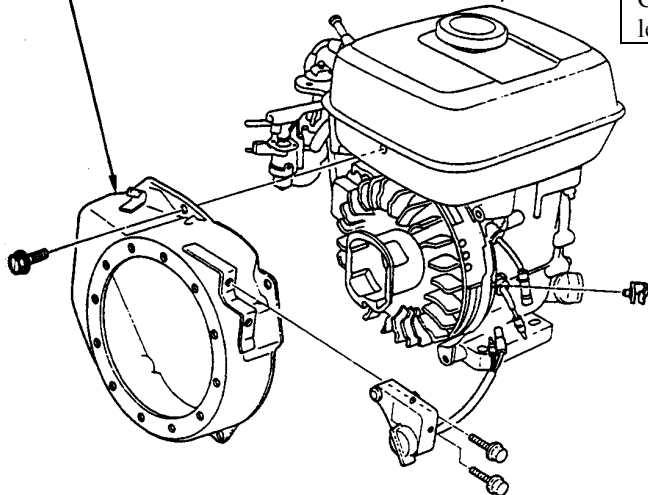

Yellow lead
Connect to oil level switch)

Black/white lead
Connect to starter lead

Control box (only used for automatic starter)

Lead support (2)

Assembling: Insert it into fan cover

Ignition coil lead (black)

Starter relay lead

White lead

Oil level switch lead (yellow)

Oil level switch lead (green)
(to side plate)

Charging coil lead (white)

Black/red lead

To ignition coil lead

Yellow lead

Connect to oil level switch yellow lead

Gray lead

Connect to charging coil lead

- Lead harness method (only used for engine with a starter) After connecting leads, fix them with zipper jacket, cable with collar, and clip as shown as following

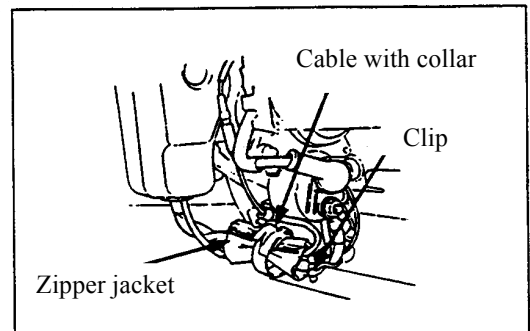

4-4-1 Recoil starter

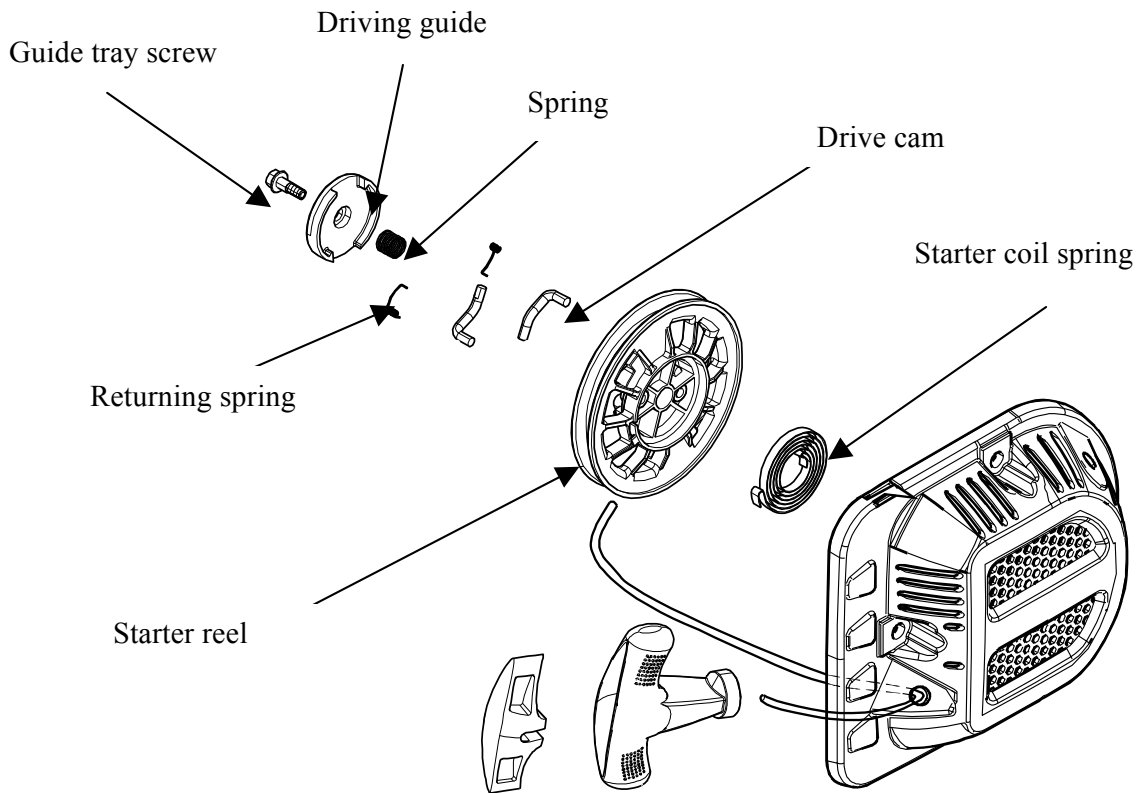

NOTICE:

Wear gloves and eye protection during disassembling, and take care not to allow the return spring to come out

⊖ Insert the recoil starter rope through the groove in the recoil starter reel and make a figure-eight knot at the rope end

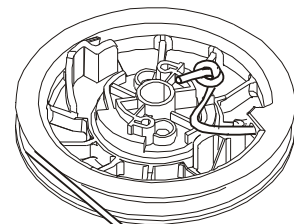

⊖ Hang the side hook of the recoil starter spring to the groove of the recoil starter case, set the recoil starter spring into the case while counterclockwise rotating starter spring

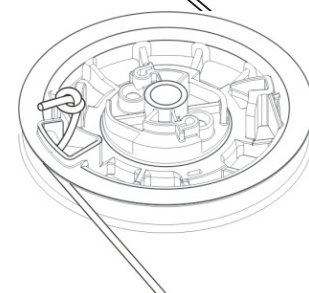

- . Set the recoil starter coil spring's outside hook to the groove of the recoil starter reel.

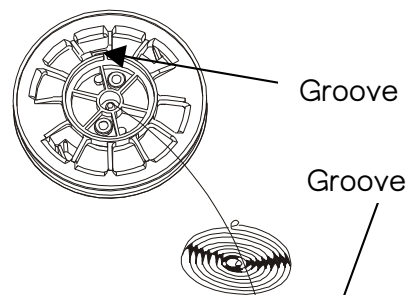

- . Set the starter drive cam on the recoil starter reel, and install the return spring on the recoil starter reel while hooking it to the side of the driving cam.

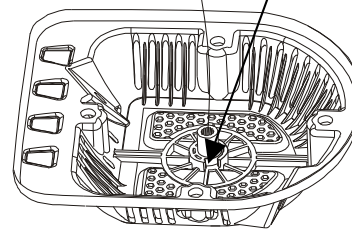

- . Install the spring, driving guide and fixing screw one after another

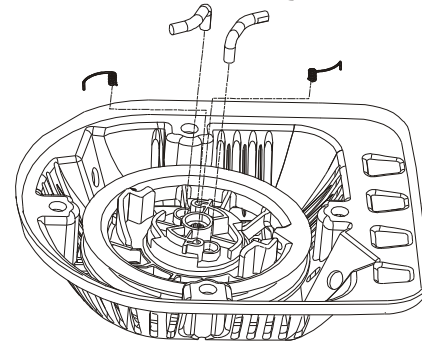

- . Insert the recoil starter rope through the recoil starter case and recoil start handle, and make a figure-eight knot at the rope end.

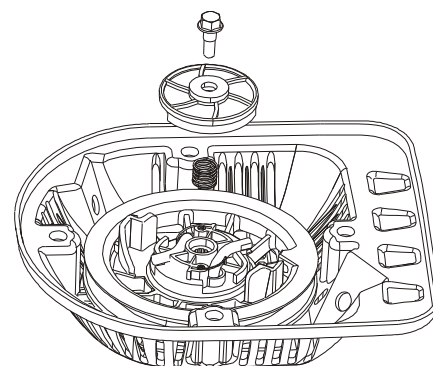

- . Pull the recoil starter rope lightly to check the drive cam's function.

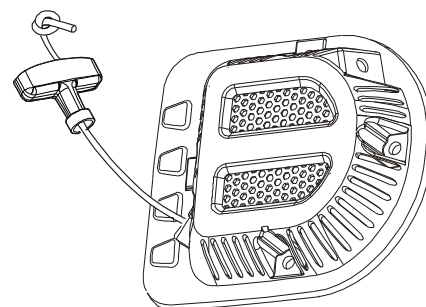

4-4-2 Flywheel

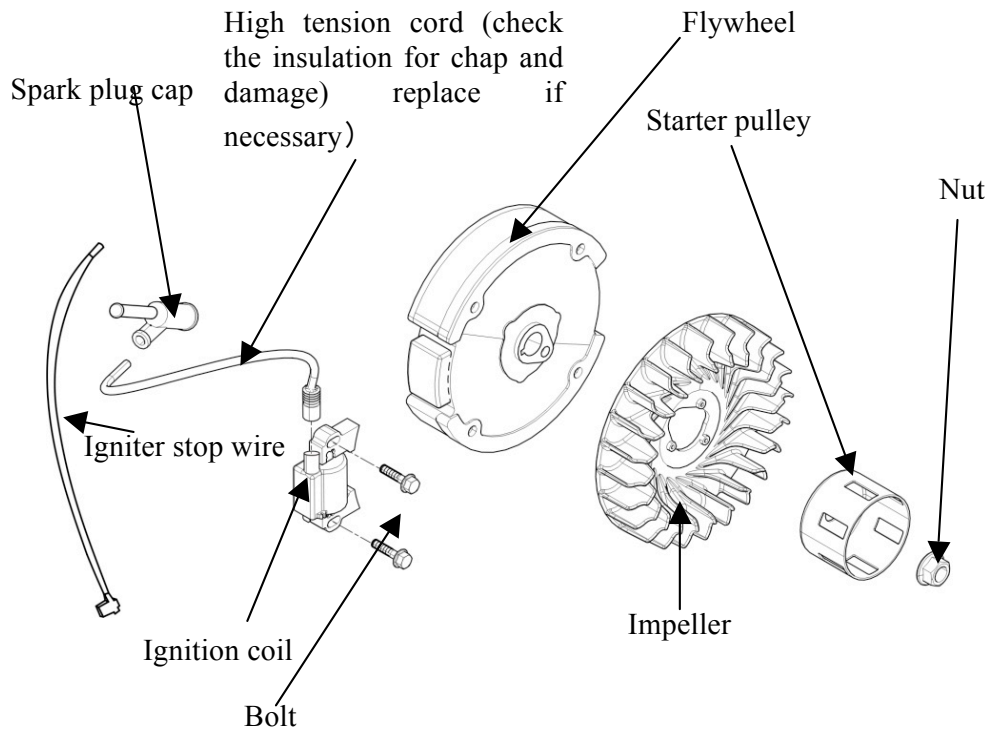

- Remove the fuel tank, air cleaner, carburetor and recoil starter assy.
- Measure the clearance between the ignition coil and flywheel with the feeler.
- Adjust the clearance of the ignition and flywheel.
- Adjusting method: Loosen the bolt and move the ignition coil up and down for adjusting the clearance, then, screw down the bolt.

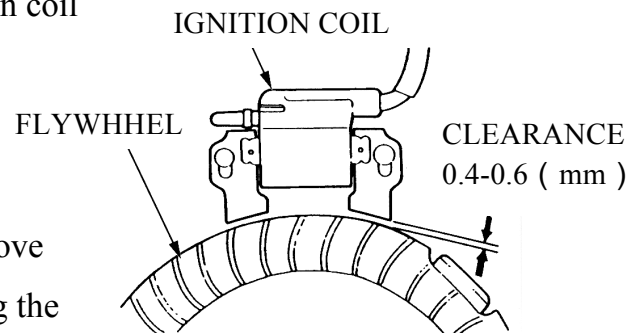

Check the ignition coil

(Primary side)

Measure the resistance of the primary coil by attaching one ohmmeter lead to the ignition coil's primary lead while touching the other test lead to the iron core.

Primary side resistance value : 1.0-1.5Ω(recommended value)

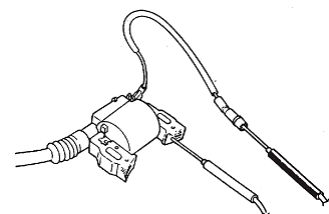

(Secondary side)

Measure the resistance of the secondary side of the coil with the spark plug cap removed, touch one test lead to the high tension cord while touching the other test lead to the coil's iron core.

Secondary side resistance value : 5-7kΩ(recommended value)

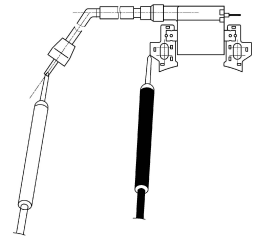

Measure the resistance of the spark plug cap by attaching one ohmmeter lead to the wire end of the plug cap while touching the other test lead to the spark plug end.

Resistance value : 5kΩ±5%/10kΩ±5%(recommended value)

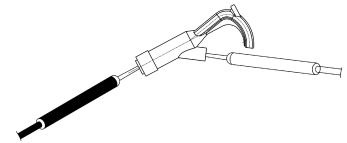

Flywheel (cast iron)

- Assemble by aligning the four small holes in the flywheel.
- Assemble by aligning the lug on the rear side of the starter pulley with the small hole at the center of the flywheel.

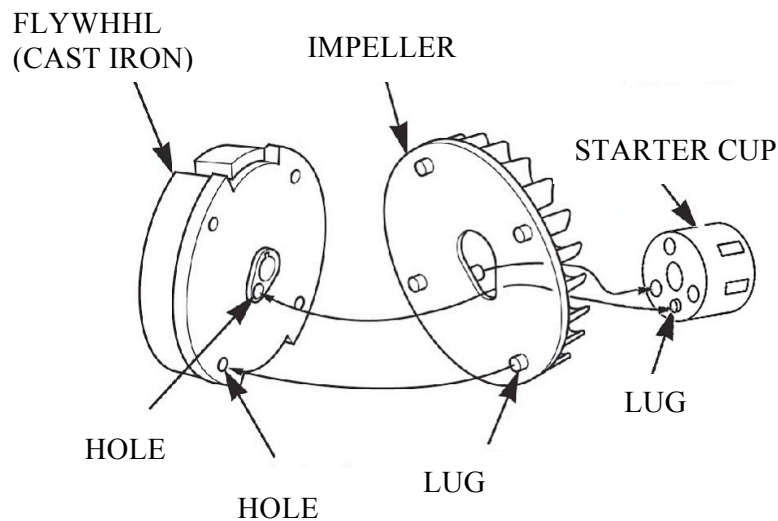

4-4-3 Air cleaner

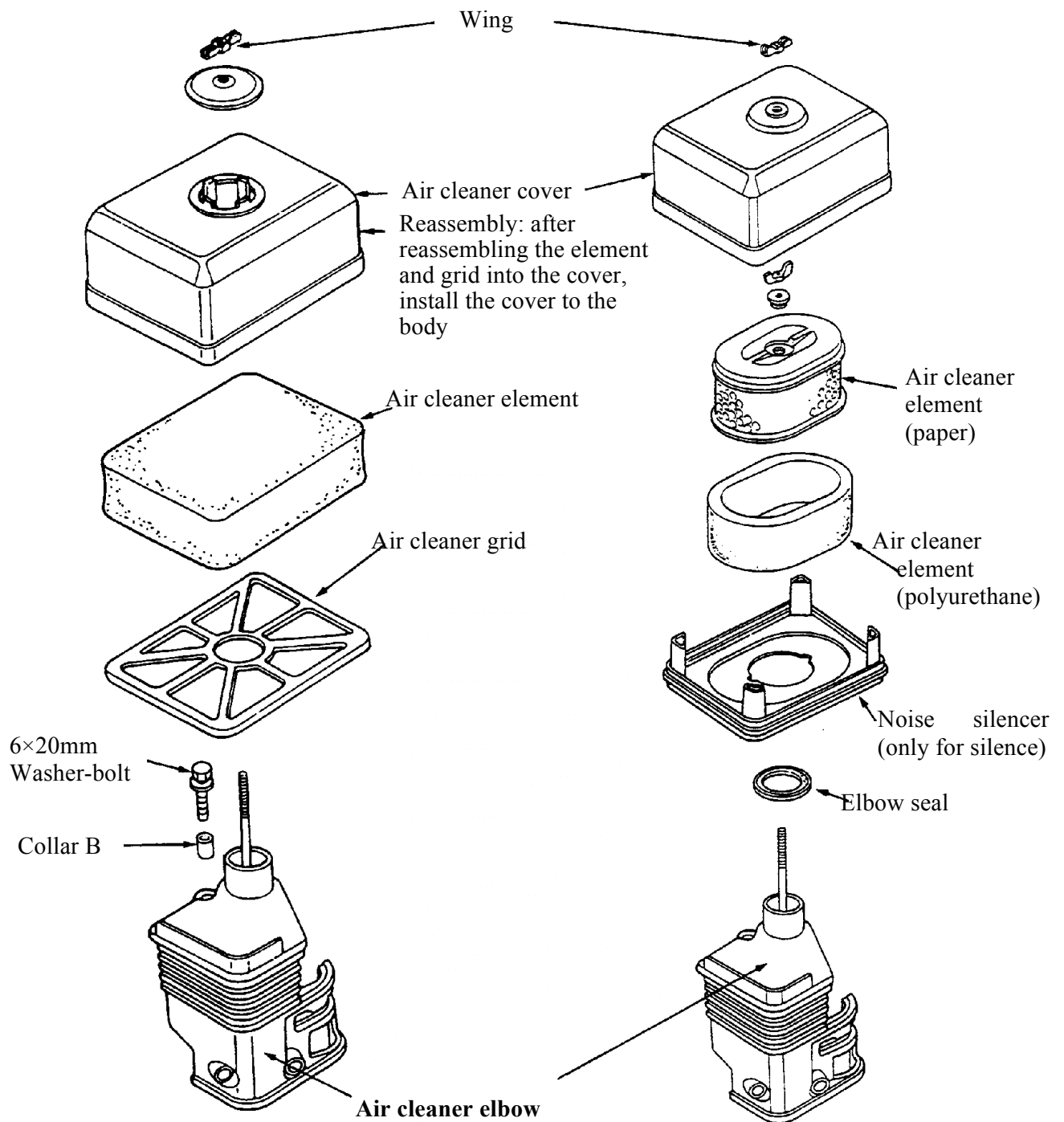

Disassembly/reassembly:
 · remove and install with the choke lever and fuel valve in the ON position
 · Clean the inside of the elbow with compressed air before installation.

Oil bath type

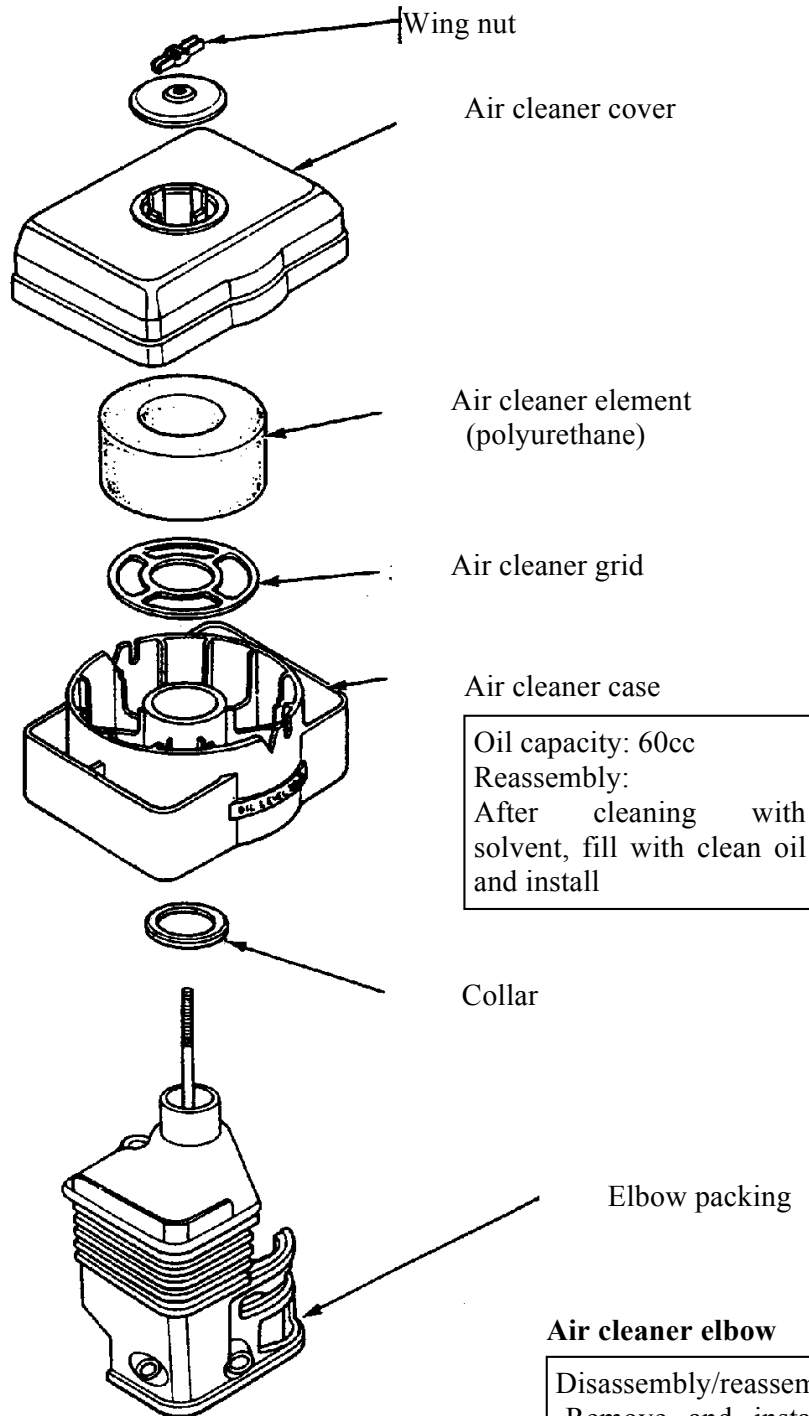

4-4-4 Carburetor

a · Disassembly/reassembly

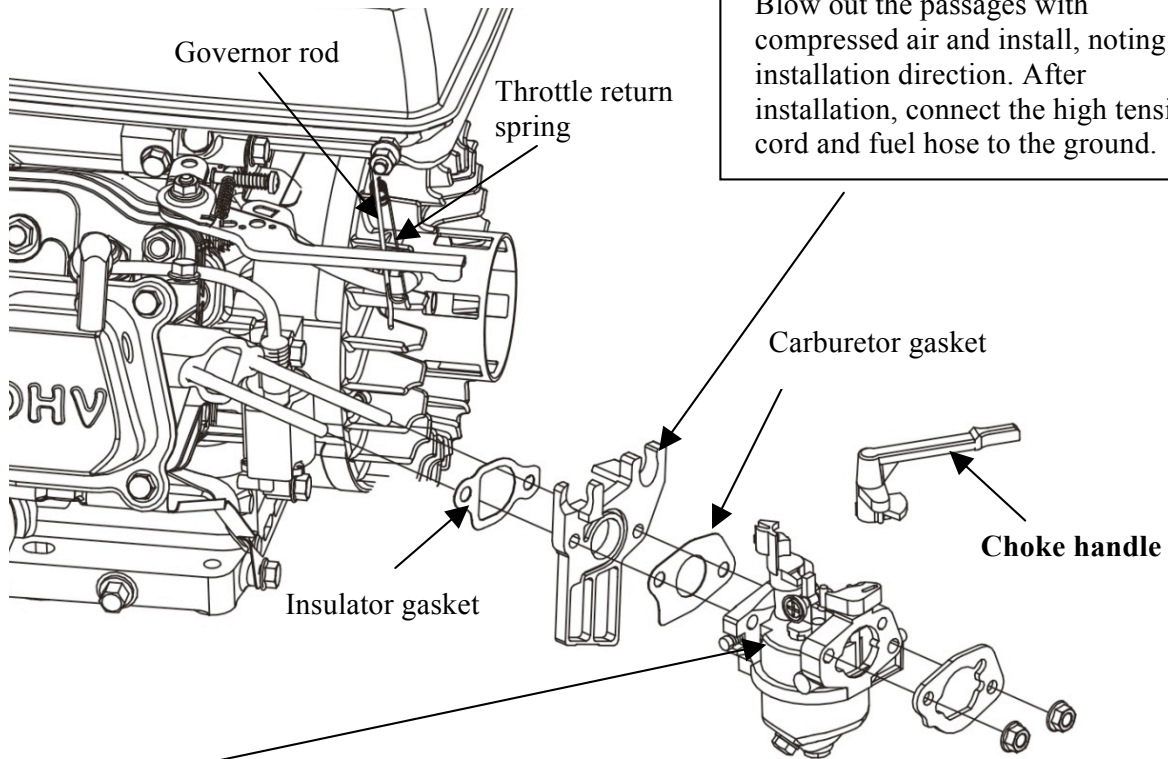

Carburetor insulator

Reassembly:

Blow out the passages with compressed air and install, noting installation direction. After installation, connect the high tension cord and fuel hose to the ground.

Carburetor assy.

Disassembly:

Unhook the throttle return spring. Pull the carburetor forward to a point where the groove in the governor rod lines up with the governor rod, and lift the rod out of its hole.

Throttle

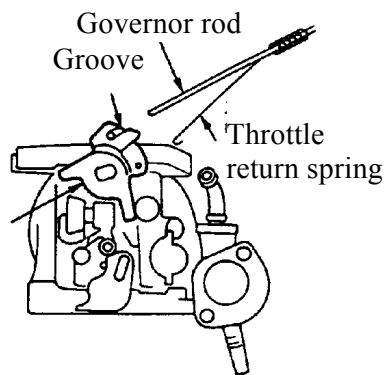

Reassembly:

After pulling fuel hose from the carburetor, insert it into protruding shoulder of the choke handle, preventing oil leakage.

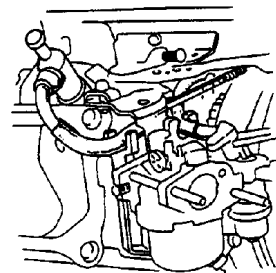

b · Disassembly/reassembly

CAUTION

- Remove the drain plug and drain the carburetor before disassembling
- Prohibit fire.

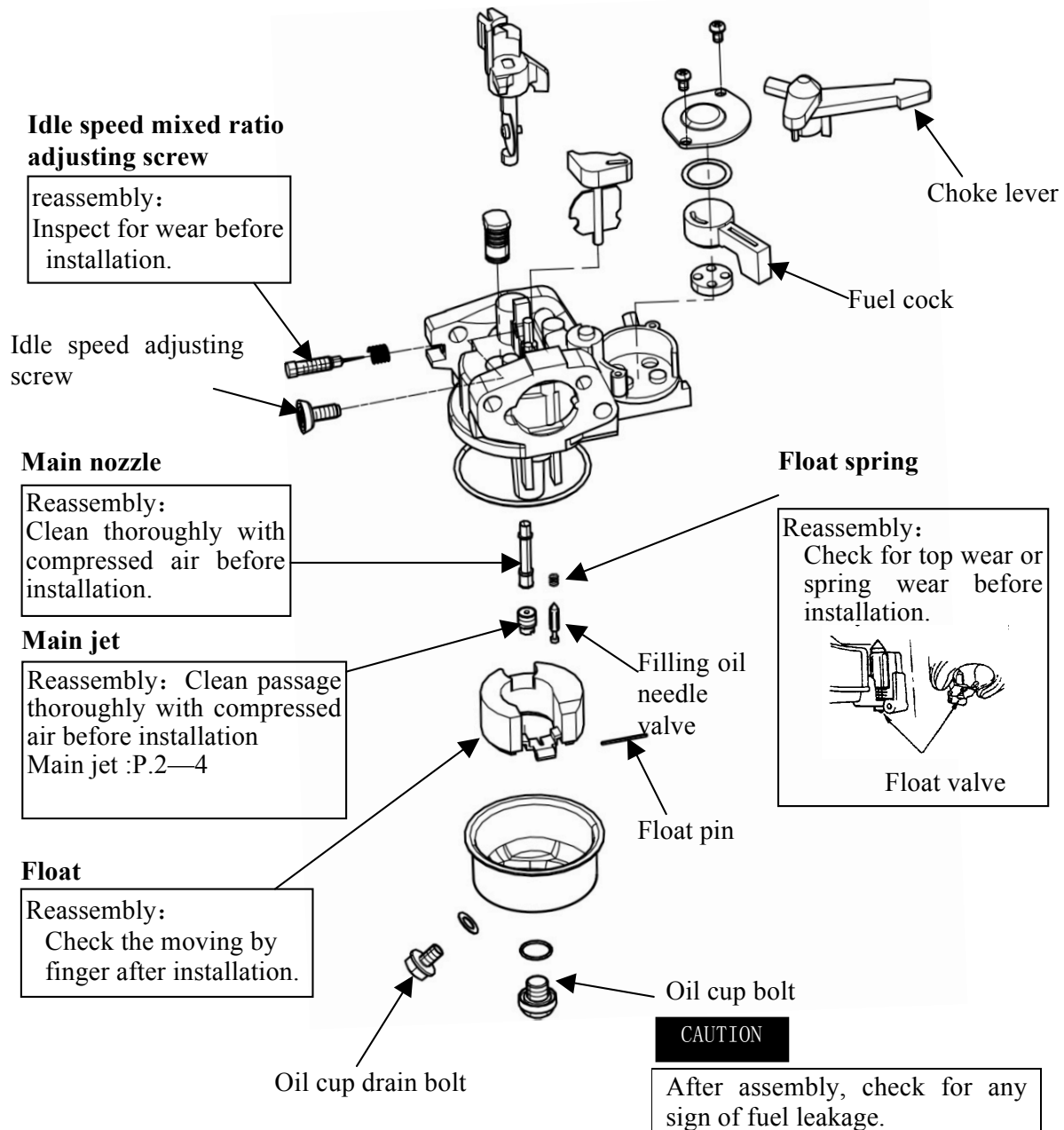

Inspection

- Float level height

Place the carburetor in the position as shown and push the float in by finger and measure the distance between the float top and carburetor body (float height).

Specified float height	See 1-3Maintenance Standard
------------------------	-----------------------------

If the float height is out of specification, replace the float valve and recheck the float height

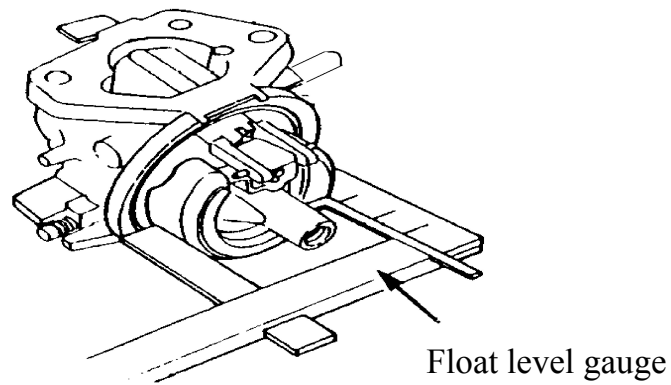

4-4-5 Cylinder head /valve

1) Removal/ installation

- Remove the fuel tank
- Remove the air cleaner
- Remove the recoil starter and shroud
- Remove the carburetor and insulator

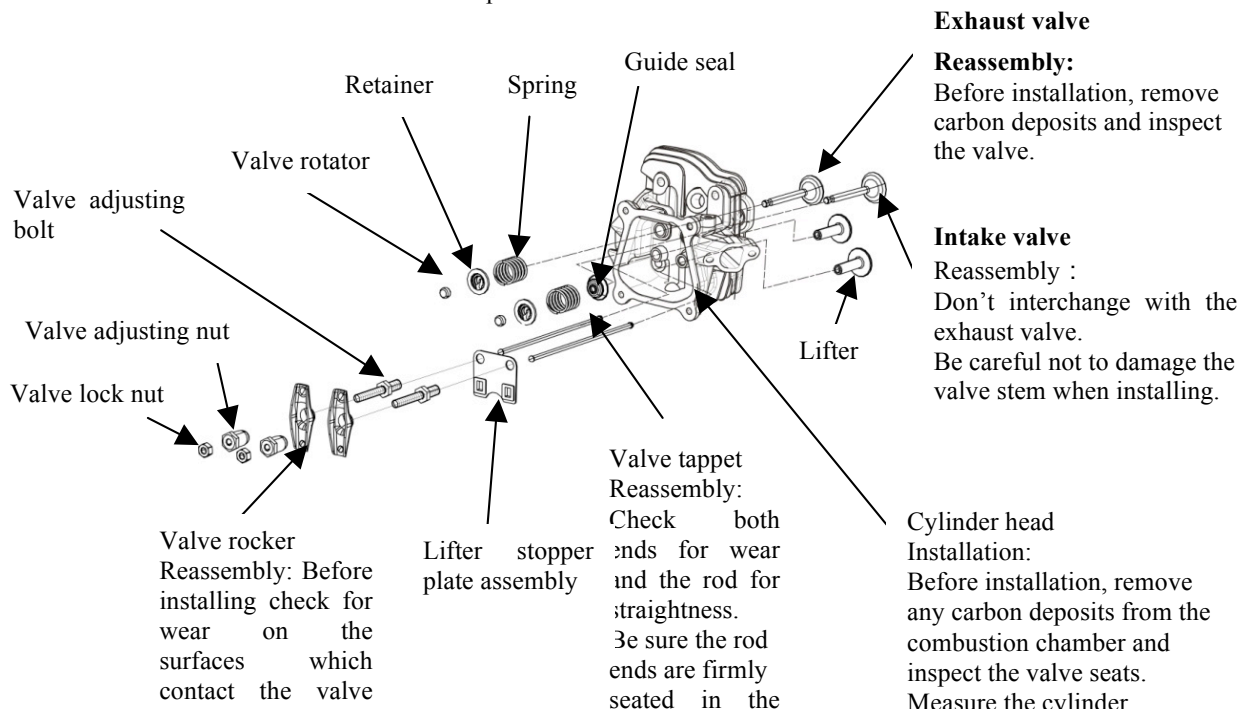
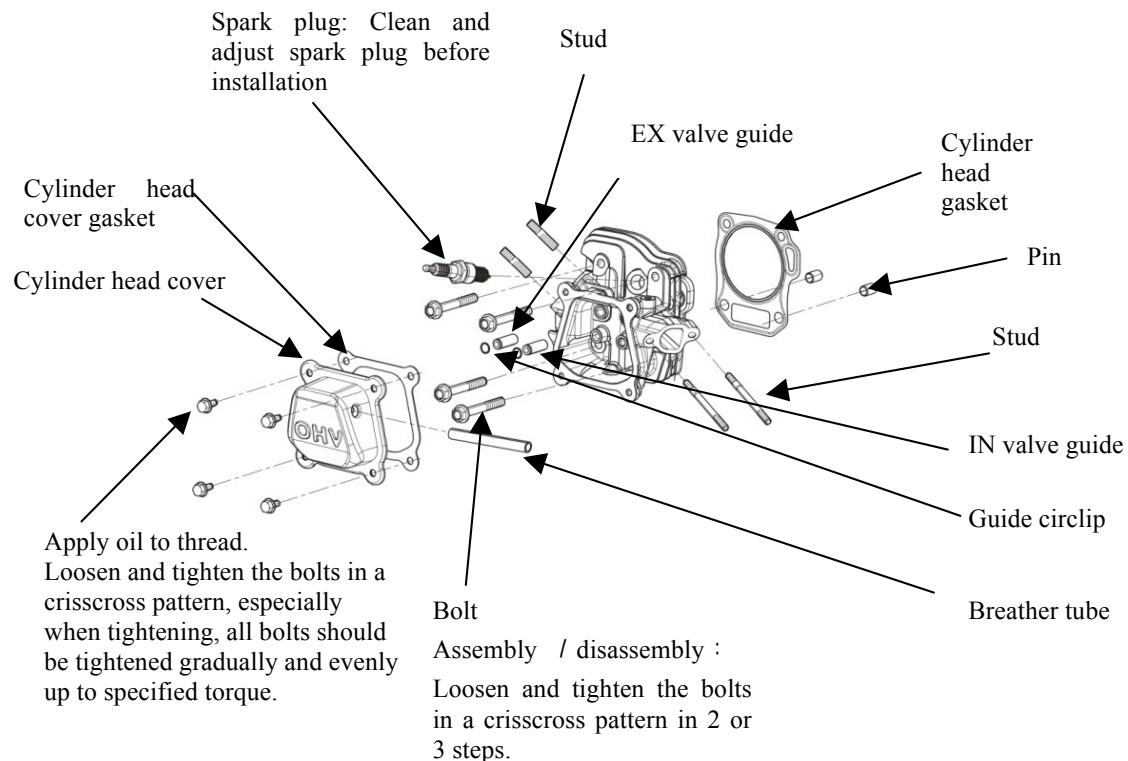

Valve spring retainer :

Push down on the valve spring and move the retainer to the side so that valve stem slips through the side hole

Do not remove the valve spring retainers while the cylinder head is installed to the cylinder, or the valves will drop into the cylinder.

2) Inspect/service/repair :

Valve stem outside diameter

Inspect the valve stem outside diameter with the micrometer, if it is found out of the standard or service limit, or if it has visible burn and damage on the valve face, please replace it with new one.

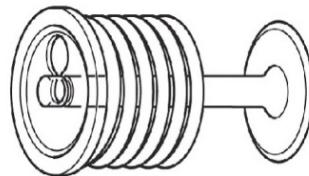
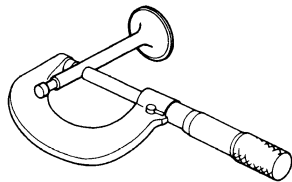

Standard	Service limit
See 1-3Maintenance Standard	See 1-3Maintenance Standard

Valve spring free length

Measure the free length of the valve

Springs: If out of the standard or service limit; please replace the spring

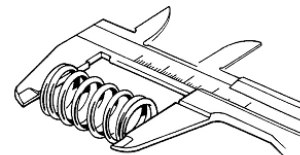

Standard	Service limit
See 1-3Maintenance Standard	See 1-3Maintenance Standard

□ **Valve guide**

Inspect :

a) Inspect the valve guide for smoothness, scratch and damage in the inner surface, and matching between the valve guide and cylinder cover for fastness.

b) Use the valve guide reamer, ream the valve guides to remove any carbon deposits before measuring.

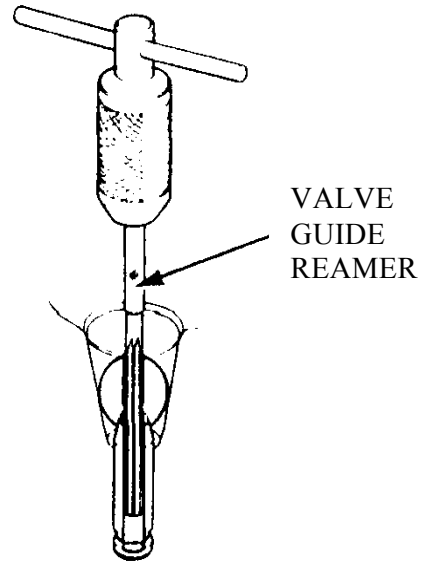

If the valve guide inside diameter is lower than standard or out of the service limit, replace the guide.

Standard	Service limit
See 1-3Maintenance Standard	See 1-3Maintenance Standard

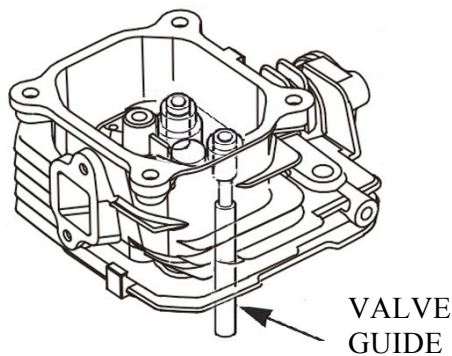

Replacement:

- a) Chill the replacement valve guides in the freezer section of a refrigerator for about an hour.
- b) Drive the valve guide out of the combustion chamber side using valve guide driver.

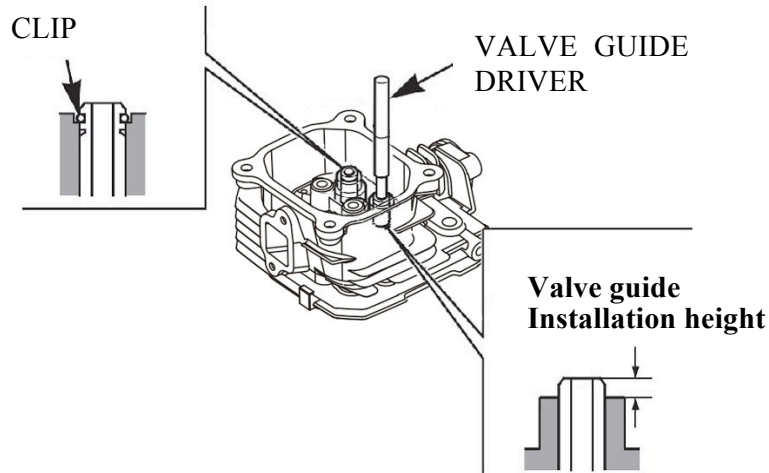

NOTICE: Be careful to avoid damaging the cylinder head when driving out the valve guides.

- c) Install the new valve guides from the valve spring side of the cylinder head.
Exhaust side: Drive the exhaust valve guide until the clip is fully seated (as shown in the fig.)
Intake side: Drive the intake valve guide to the specified height (measured from the top of the valve guide to the cylinder cover as shown in the fig.)
- d) After installation, inspect the valve guide for damage, if it is damaged, please replace.

Reamer :

For best results, be sure the cylinder head is at room temperature before reaming valve guides.

- a) Coat the reamer and valve guide with cutting oil.
- b) Rotate the reamer clockwise through the valve guide for the full length of the reamer. Continue to rotate the reamer clockwise while removing it from the valve guide.
- c) Thoroughly clean the cylinder head to remove any cutting residue.
- d) Check the valve guide bore, it should be straight, round and centered in the valve guide, insert the valve and check operation. If the valve does not operate smoothly, the guide may have been bent during installation. Replace the valve guide if it is bent or damaged.
- e) Check the valve stem-to-guide clearance
- f) The valve stem-to-guide clearance:
- g) Deduct the valve stem outside diameter from the valve guide bore to get the clearance between the valve guide and valve stem.
- h) If the clearance is over the service limit, judge whether new guide can make the clearance conform to service limit, if it can, replace the guide and ream the guide, refinish the valve when replacing the valve guide.

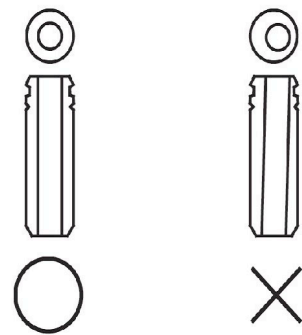
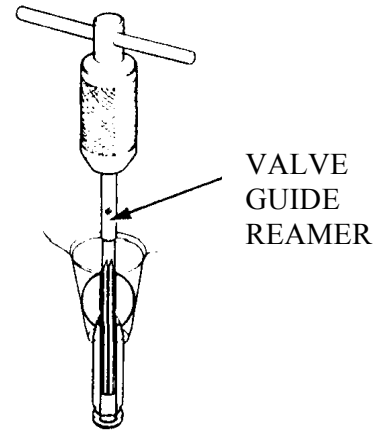

CORRECT

INCORRECT

□ **Valve seat :**

a) Thoroughly clean the combustion chambers and valve seats to remove carbon deposits. Apply a light coat of red lead powder or erasable color painting to the valve faces.

Insert the valves, and then press the valve several times forcefully. Be sure the valve does not rotate on the seat.

The transferred marking compound will show any area of the seat that is not concentric.

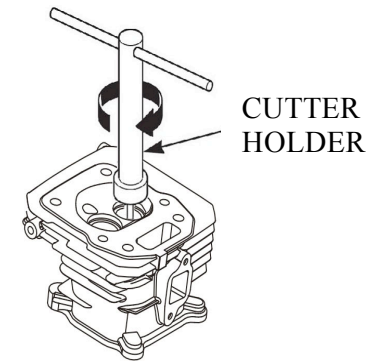
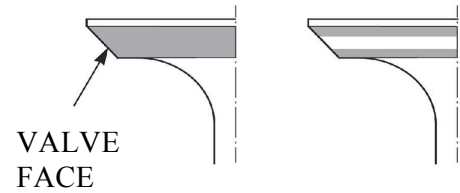

b) Using 45°cutter, remove enough material to produce a smooth and concentric seat.

c) Turn cutter clockwise, never counterclockwise.

d) Continue turning the cutter as you lift it from the valve seat.

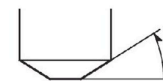

IN valve : 32°

EN valve : 32°



IN valve : 45

EX valve : 45

Tool :

Valve seat cutter

Use the 32°-45°cutters to narrow and adjust the valve seat so that it contacts the middle of the valve face. The 32°cutter removes material from the top edge (contact too high).

The 45°cutter removes material from the bottom edge (contact too low). Be sure that the width of the finished valve seat is within specification.

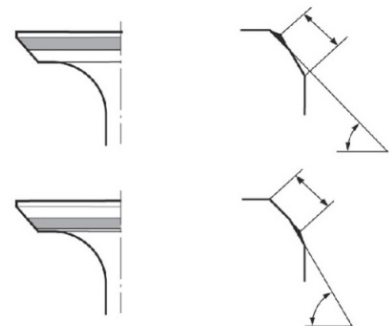

Standard	Service limit
See 1-3Maintenance Standard	See 1-3Maintenance Standard

d) Make a light pass with the 45°cutter to remove any possible burrs at the edges of the seat.

4-4-6 Crankshaft/piston

Oil seal

- Don't reuse
- Apply oil to lip of the oil seal

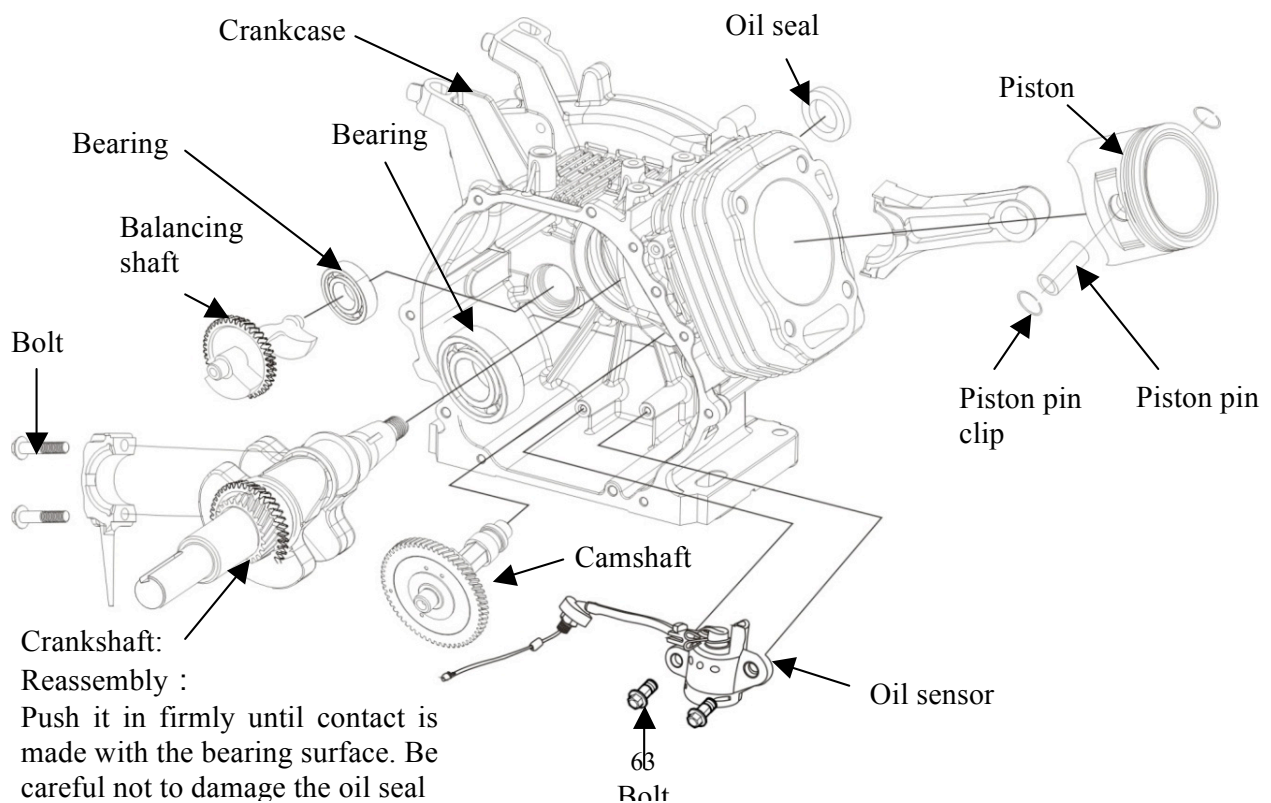
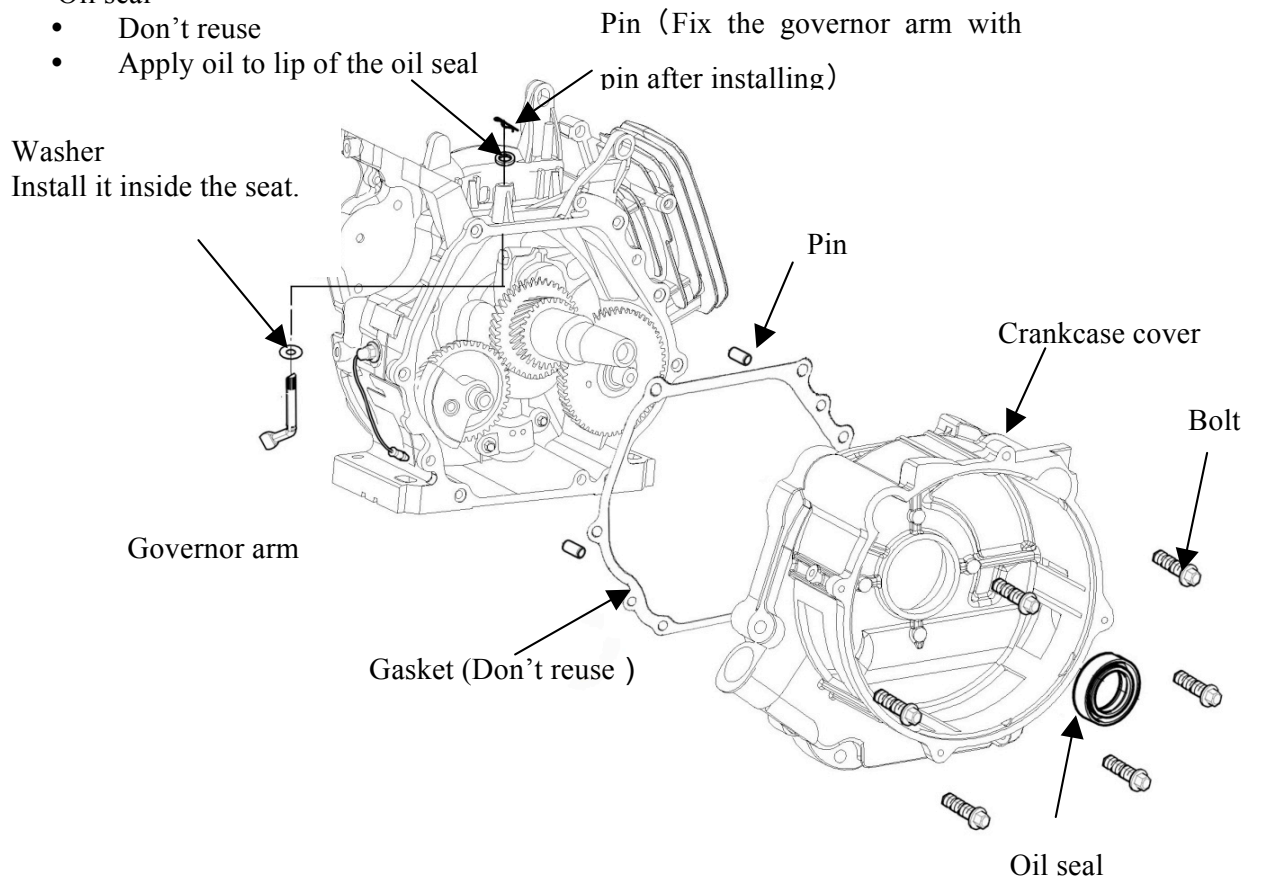

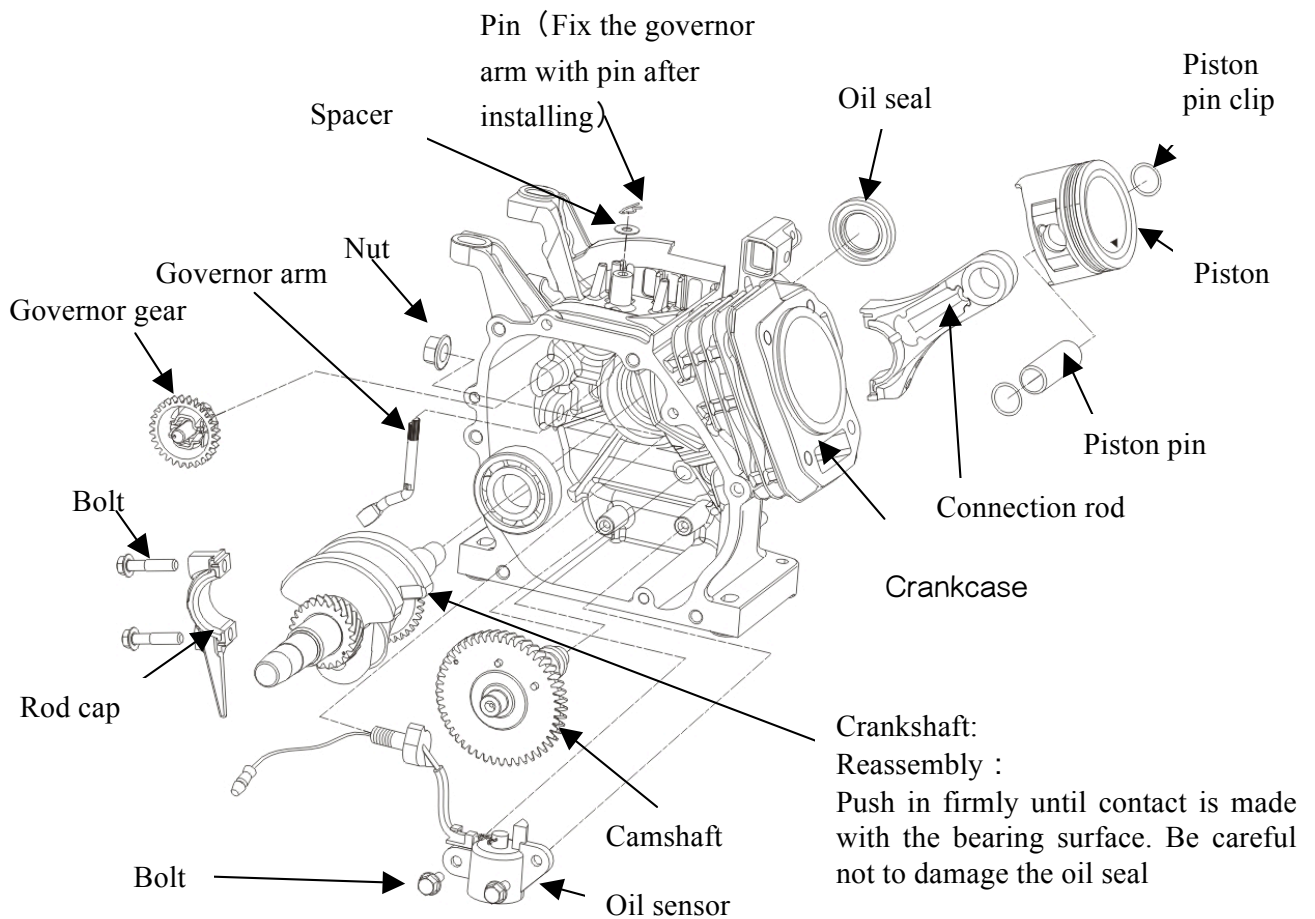
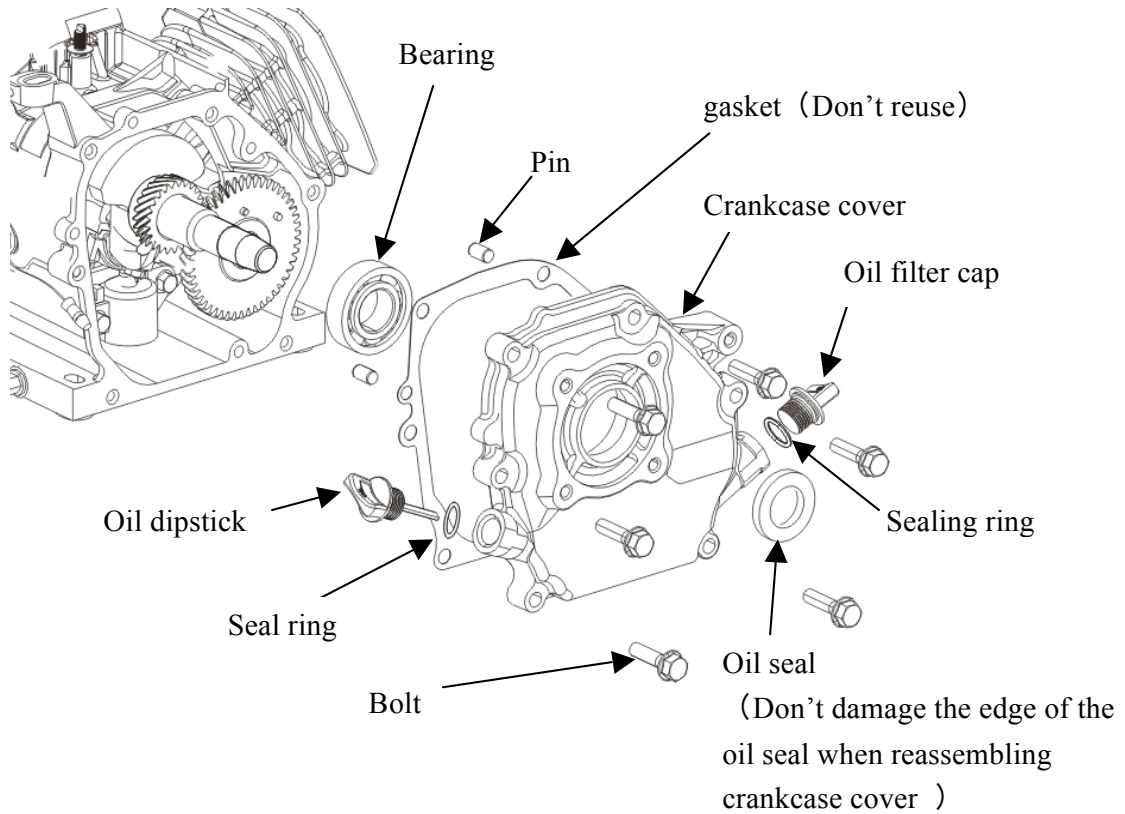

□ Disassembly :

a) Piston

- Install with the marker marking facing upward as shown.
- Do not interchange the first ring and the second ring (first ring is chrome plated)
- After assembly, check for smooth movement of the piston rings.
- Stagger the piston ring end gaps 120° apart.

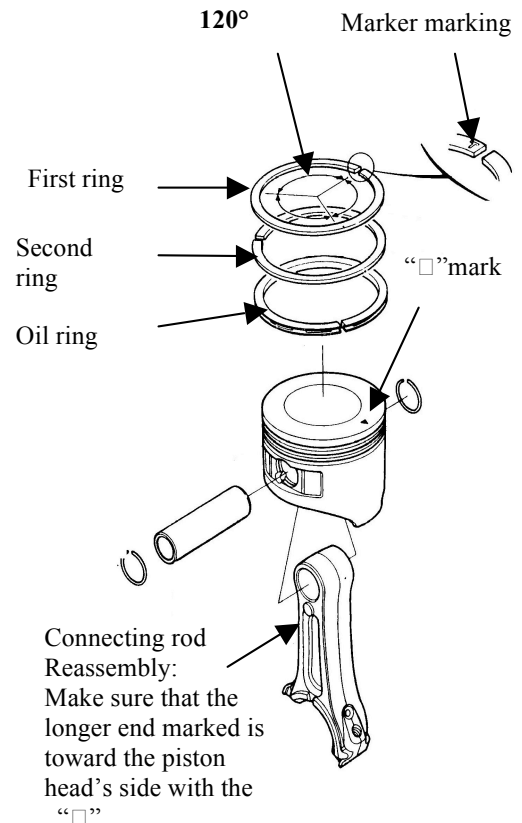

□ Reassembly :

a) Piston pin clip

Install by setting front end of the clip in the piston groove, holding the other end with long nosed pliers, and rotating the clip in.

Do not align the end gap of the clip with the cutout in the piston pin bore.

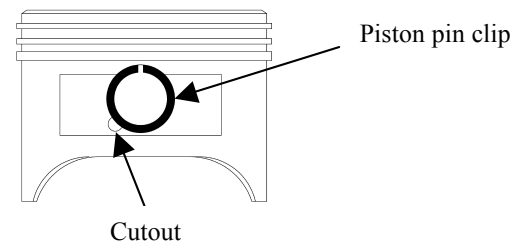

c) Connecting rod cap

Install by aligning the alignment marks on the connecting rod cap.

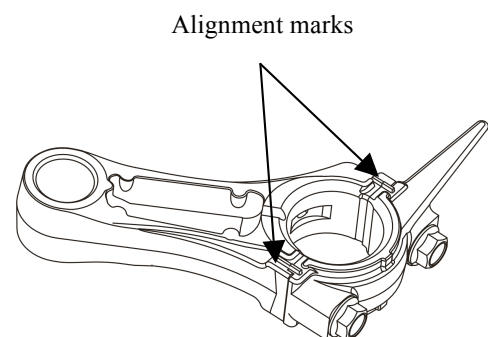

□ Piston check

Check the piston and cylinder for contacting, and check the groove for defects, piston top for burn and cracks. If any of them is damaged, replace it.

Clean the carbon deposit

Clean the deposit round the piston top and cylinder neck before checking, first soak the carbon deposit with kerosene, then clean with a metal scraper or metal brush.

a) Piston skirt O.D

Measure the piston skirt O.D with an outside micrometer, if it is out of the service limit, replace it.

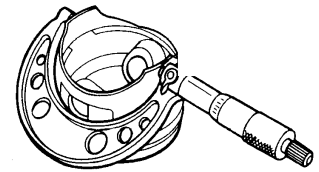

Standard	Service limit
See 1-3Maintenance Standard	See 1-3Maintenance Standard

b) Piston pin bore to piston clearance

Separately measure the piston pin bore I.D and O.D with inside micrometer and outside micrometer. Then calculate clearance by measuring results. If out of the service limit, replace the piston pin and piston as necessary.

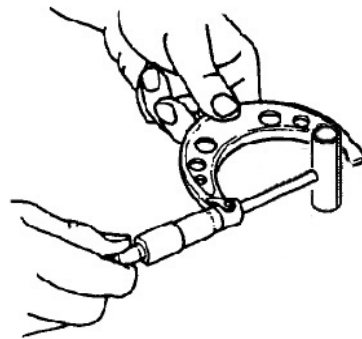
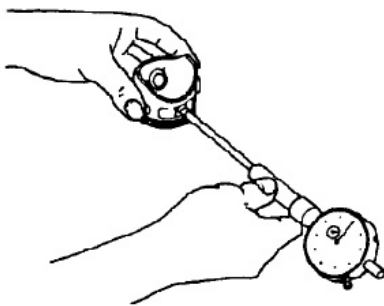

Standard	Service limit
See 1-3Maintenance Standard	See 1-3Maintenance Standard

c) Piston-to-cylinder clearance

Difference between cylinder maximum diameter and piston skirt should be considered as piston-to-cylinder clearance.

NOTICE: This clearance must be checked before and after repairing.

Check with piston upside down in the cylinder, and inserting feeler between piston skirt bearing face and wall, then pull the feeler out, if feeling resistance and moving smoothly out, the thickness of the feeler shall be considered as piston-to-cylinder clearance.

Standard	Service limit
See 1-3Maintenance Standard	See 1-3Maintenance Standard

d) Piston ring side clearance

Check by placing each ring into its groove. The piston ring should be freely turned without loosening and sticking. Then measure by inserting the feeler into clearance of the ring and upper and lower face.

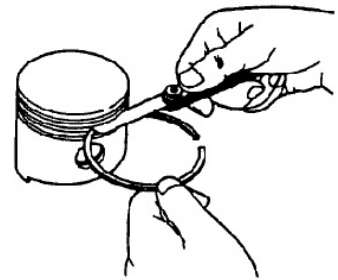

Standard	Service limit
See 1-3Maintenance Standard	See 1-3Maintenance Standard

e) Piston ring end gap

Flatly place the piston into the cylinder by pushing the piston head to working position. Measure the opening clearance with a feeler, that clearance should not be too big or too small, if it is too big can, cylinder sealing performance will be poor, if it is too small, piston expanded by heat will be blocked in the cylinder, thus causing piston broken and “sticking”. If opening clearance is too small, file the opening with fine flat file. Often check in the cylinder when filing until the proper clearance is got.

Piston ring

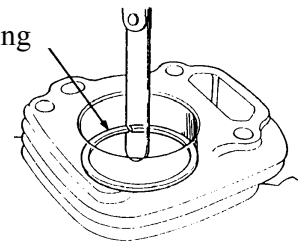

	Standard	Service limit
First ring/second ring	See 1-3Maintenance Standard	See 1-3Maintenance Standard
Oil ring	See 1-3Maintenance	See 1-3Maintenance

	Standard	Standard
--	----------	----------

□ Check connecting rod

If connecting rod is bent or twisted, or its big end shaft hole and small end hole have apparent grooves, or have cracks on one side, the connecting rod should be rejected and replaced with a new one.

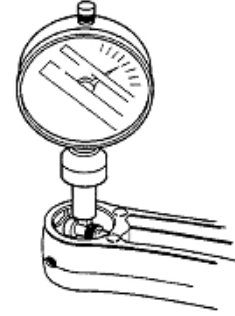

a) Check small end diameter

If it is out of the standard or exceeds service limit, replace the connecting rod.

Standard	Service limit
See 1-3Maintenance Standard	See 1-3Maintenance Standard

b) Check big end diameter

If it is out of the standard or exceeds service limit, replace the connecting rod.

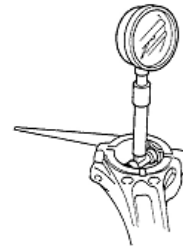

Standard	Service limit
See 1-3Maintenance Standard	See 1-3Maintenance Standard

c) Connecting rod big end oil clearance

- Wipe oil off the crank pin and connecting rod bearing mating surface.
- Set the plastic gauge on the crank pin, then install connecting rod and fasten bolts to specified torque.

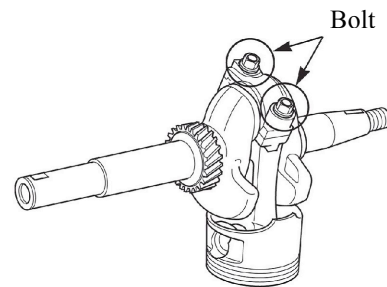

Torque : See 1-3Maintenance Standard

NOTICE: Place the plastic gauge axially.

- **Remove connecting rod and measure with plastic gauge.**
- If the clearance exceeds the service limit, replace the connecting rod and recheck the clearance.

Standard	Service limit
See 1-3Maintenance Standard	See 1-3Maintenance Standard

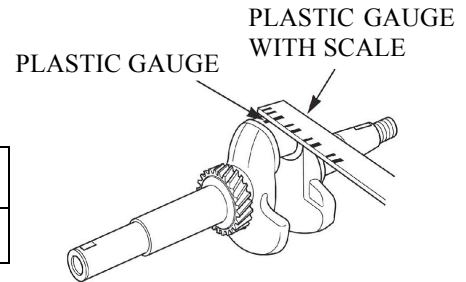

□ Camshaft check

The camshaft is main driving part of the valve timing mechanism, which controls the intake and exhaust valves' opening and closing.

Feature: The shaft is equipped with a cam and journal which can control intake and exhaust. When operating, camshaft operating face and lifter will be badly rubbed from periodical impact and will be easily damaged. So, the camshaft shall be wearable and lubricated well.

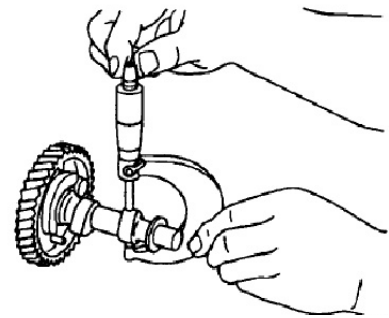

- Visually inspect camshaft face and camshaft height for damage, and camshaft and bearing for loosening and wear, replace if necessary.
- Check camshaft for height. If it is out of the service limit, replace the camshaft.

	Standard	Service limit
IN lifter	See 1-3Maintenance Standard	See 1-3Maintenance Standard
EX lifter	See 1-3Maintenance Standard	See 1-3Maintenance Standard

- Check outside diameter of the camshaft, if it is less than the service limit, replace the camshaft.

Standard	Service limit
See 1-3Maintenance Standard	See 1-3Maintenance Standard

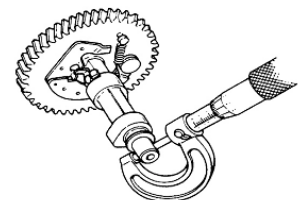

Camshaft wearing cause and its influence on engine performance:

Poor lubrication, caused by factors such as low oil viscosity, too many impurities, and little recycling oil, will result in camshaft abnormal wearing, making it hard for the camshaft surface to have a complete oil film, causing the camshaft surface seriously worn in the state of high-speed rubbing; installing precision problem is also a factor that can cause lubrication problem, when the matching clearance of the camshaft journal and camshaft seat or bearing is out of the service limit, camshaft rotation precision will lower and contacting with the relative part will produce deviation to make abnormal wearing.

□ Timing gear

a) Check timing gear for engagement clearance and align marks of the gears on two sides.

Timing gear will be damaged if gear is worn, gear face peels off, and gear teeth are broken.

The engagement clearance is bigger due to gear wearing, the noise is bigger.

If the timing gear is damaged, please replace it with new one.

NOTICE: Please replace the gear with a new set to ensure the engaging face completely engages in.

Crankshaft and Camshaft Alignment

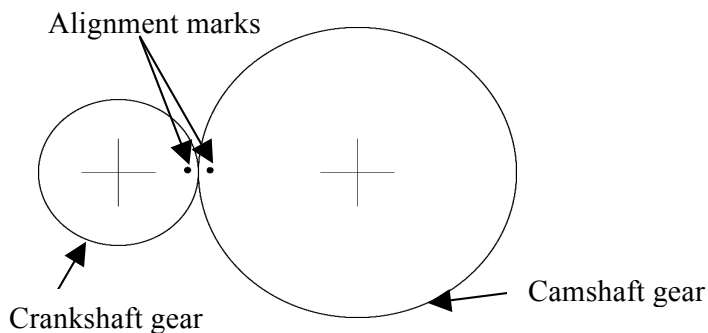

Crankshaft and Crankshaft gear Alignment

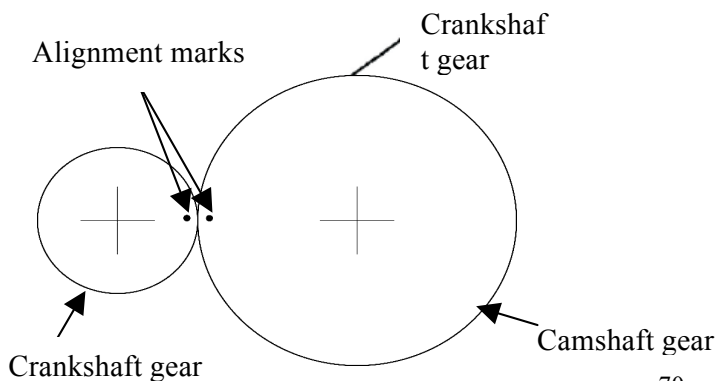

4-4-7 Starting control box

a · Disassembly/reassembly (Only for starter)

6×12mm(2)
screw

Control box

Silicon rectifier

Check : 7-8

Blade type fuse (5A)

Reassembly:

Check for burn before installation

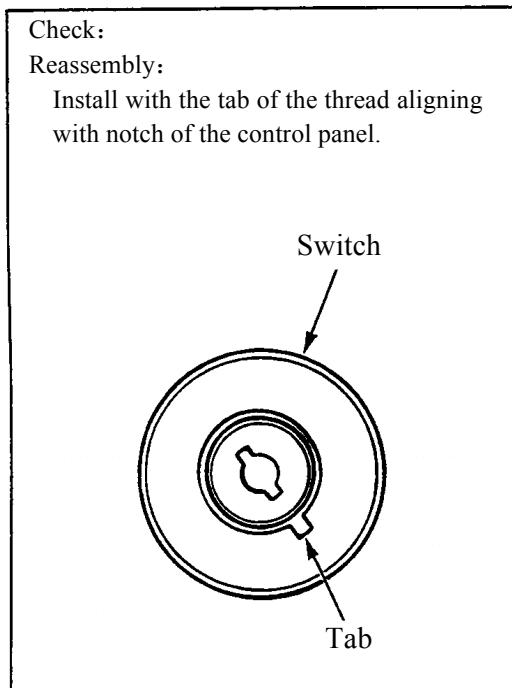
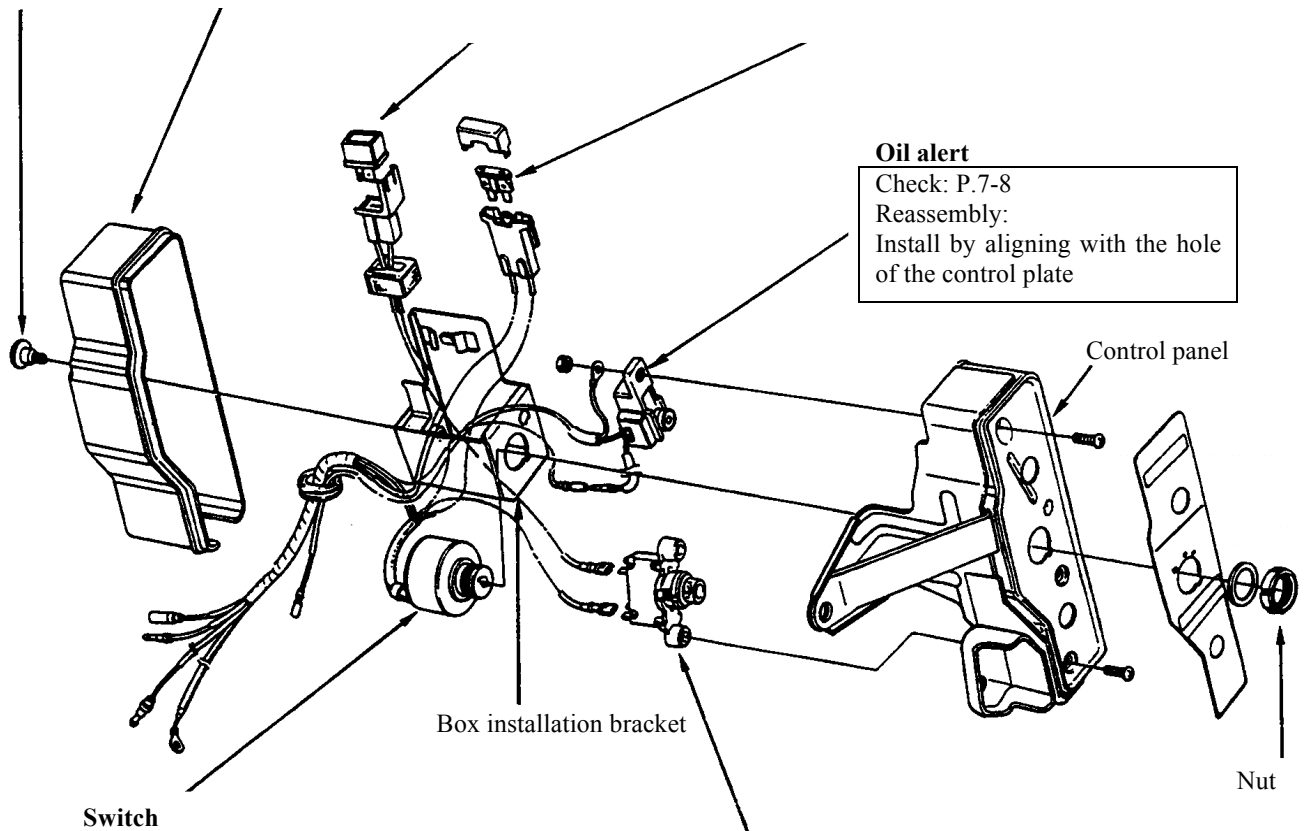

Resetting button (1A)

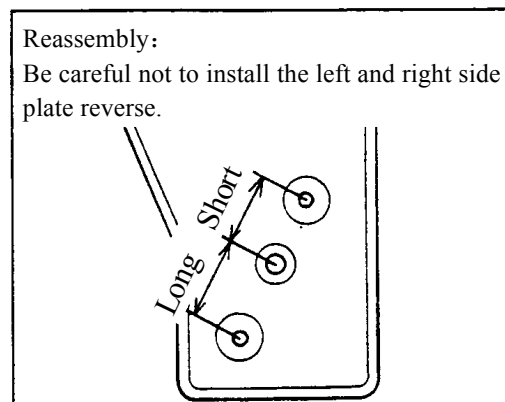

b · Check

● **Engine switch**

Check the continuity between lead and fan cover.

Switch position	Continuity
-----------------	------------

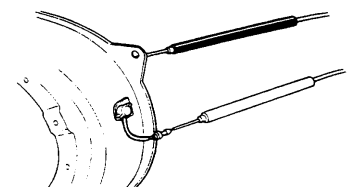

ON	No
OFF	Yes

● **Engine switch (with oil alert)**

Check the continuity between black lead and engine switch.

Switch position	Continuity
ON	No
OFF	Yes

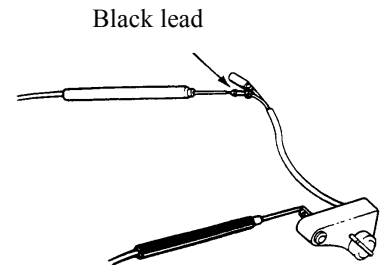

● **Switch (with starter)**

Check continuity between leads when switch is kept at each position.

Lead color	Black/red	(to grounding)	Black/white	White
Switch position				
OFF	○	○	—	—
ON				
START	—	—	○	○

Check with fuse connected

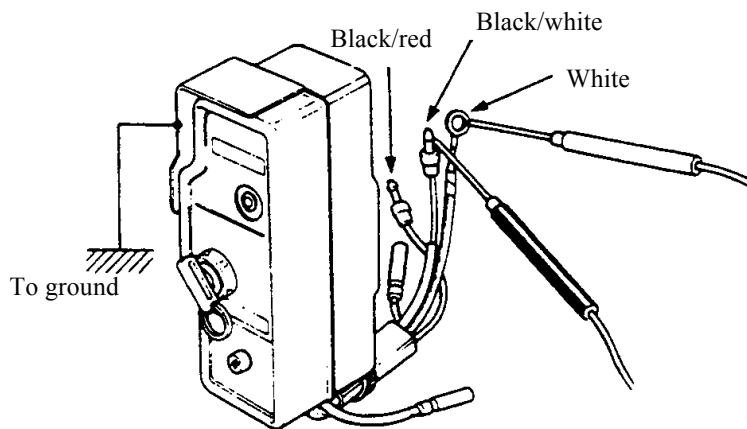

● **Oil alert lamp**

Connect the black and yellow leads to 6V battery or dry cell, check the alert lamp for lighting up.

Black—□ battery (+)

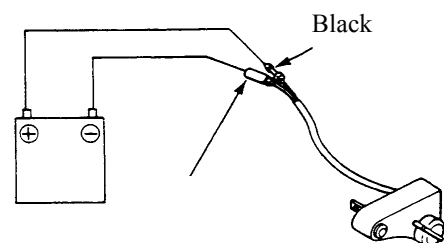

Yellow—□ battery (-)

(Don't connect the positive and negative poles wrongly)

※ Don't use the battery with over 6V, if so, bulb will break.

- Connect the black/red and yellow leads to 6V battery or dry cell, check whether the alert lamp lights up.

Black—□ battery (+)

Yellow—□ battery (-)

(Don't connect the positive and negative poles wrongly)

※ Don't use the battery with over 6V, if so, bulb will break.

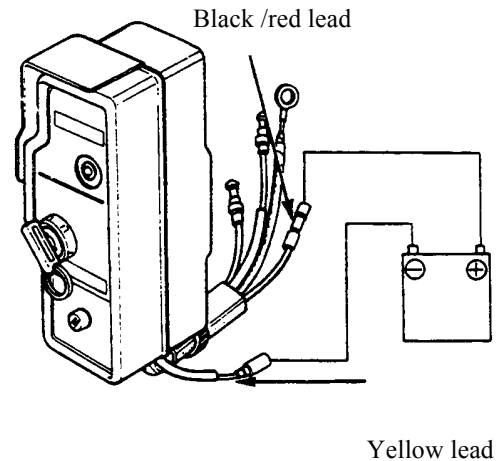

● Silicon rectifier

Check continuity between the two terminals, if it is continuous in the forward direction and uncontinuous in the reverse direction, it shall be considered as normal.

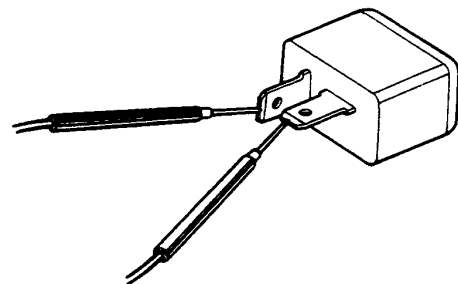

● Resetting button

Check the two terminals for continuity with resetting button turned to ON position.

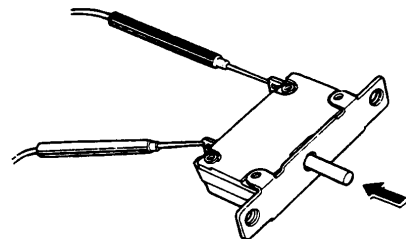

ELECTRIC DIAGRAM

Bl	black	Gr	grey
Y	yellow	R	red
W	white	G	green

switch combination

	IG	E	ST	BAT
OFF	○—○			
ON				
START			○—○	

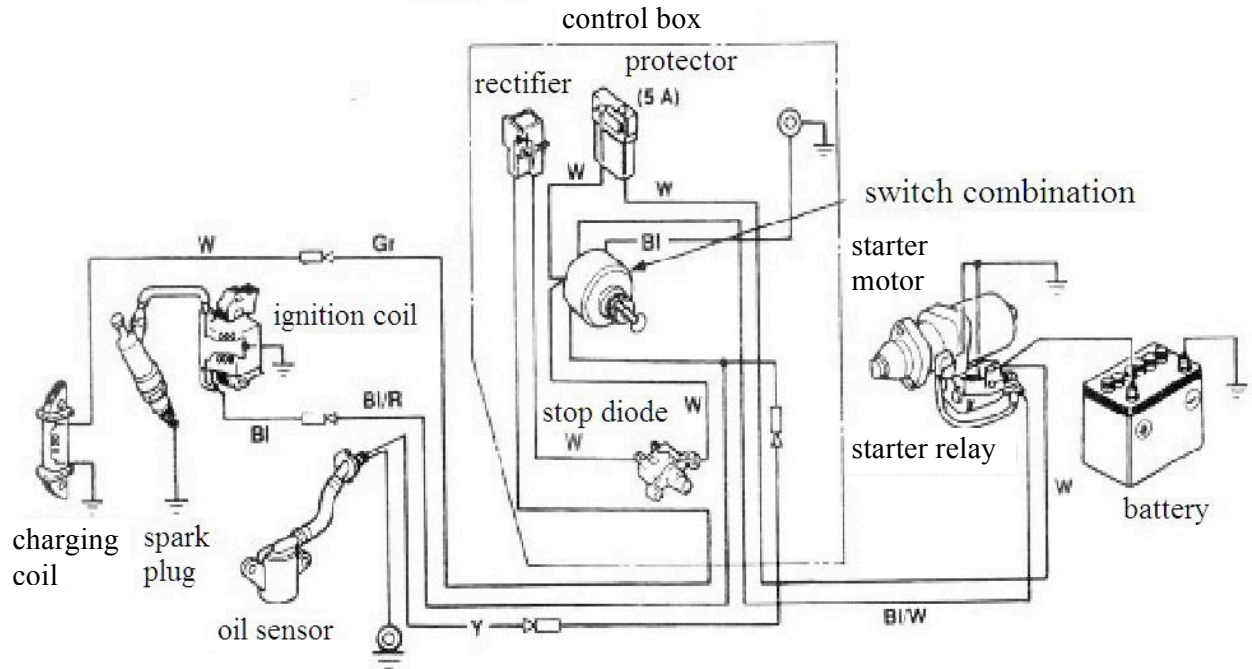

Chongqing Rato Power Manufacturing Corporation
Add: No. 99 Jiujiang Road, Shuangfu District, Chongqing
China

service hotline: 400-681-9981

fox: 023-85553450

postcode: 402247

URL: www.rato.cc

E-mail: ratoservice@rato.cc (consultation customer service)