YANMAR

SERVICE MANUAL

INDUSTRIAL DIESEL ENGINE

MODEL **L - A series**



YANMAR DIESEL ENGINE CO., LTD.

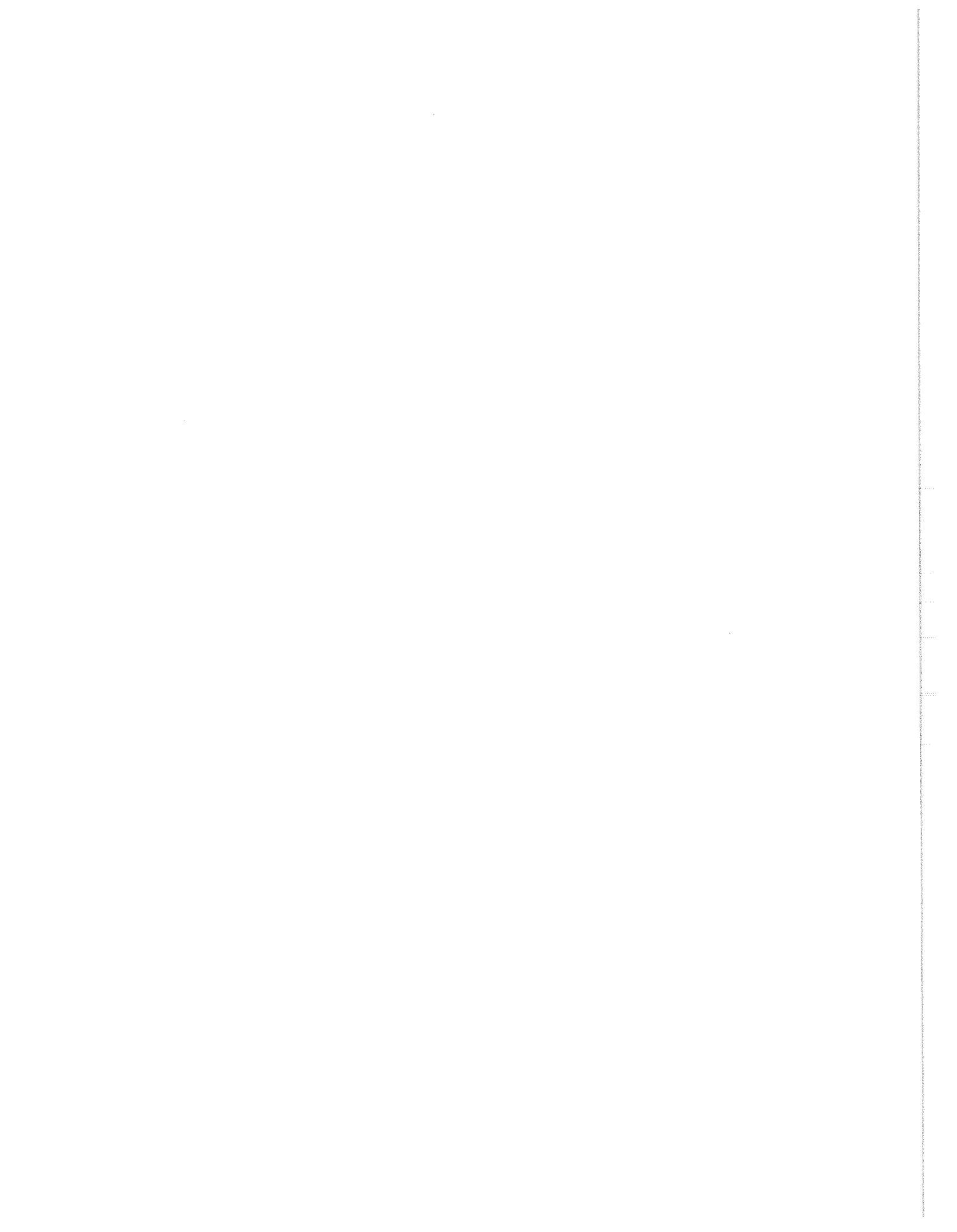

INTRODUCTION

This Service Manual offers instructions on standard service procedures (disassembly and reassembly) for Yanmar Diesel Engine models L40AE, L48AE, L60AE, L70AE, L75AE, L90AE and L100AE. More detailed information is given particularly in the sections of the construction and function of each engine part.

Before servicing these engines, make sure you read this manual carefully.

The information contained in this manual will be updated periodically to incorporate improvements in the quality and performance of our engines.

Before beginning your service work:

To insure efficient service and repairs, the following pre-service steps should be taken:

1. Check your customer control book

- (1) When was the engine last serviced?
- (2) What is the engine's service history?
 - a. How often was the engine serviced (after how many months or hours of operation)?
 - b. What problems has the engine had in the past?

2. Stock control (spare parts)

- (1) Keep a good stock of engine parts and other items necessary for efficient servicing.
- (2) Keep a copy of the check/service parts list and plenty of parts cards on hand.

3. Keep an accurate service record (diary, notes, etc.)

- (1) Work (manpower) table
 - (2) Check list (including service parts list)
 - (3) Parts measurement data
 - (4) Operation data
- } Maintenance of performance
and quality

4. Tools and equipment required for service

- (1) Tools
- (2) Meters and instruments
- (3) Others



Service Information

1. GENERAL SAFETY

WARNING

STOP THE ENGINE BEFORE SERVICING

1) PREVENTING FIRES

- Never add fuel to the fuel tank while the engine is running. Wipe away all fuel spills with a clean cloth.
- Keep gasoline, kerosene, matches, other explosives and inflammables away from the engine, since the temperature around the exhaust silencer is very high during operation.
- To prevent fire hazards and to provide adequate ventilation, keep the engine at least 3 ft (1m) away from the building and other equipment during operation.

2) PREVENTING EXHAUST GAS INHALATION

- Note that exhaust gas contains carbon monoxide (CO), nitrogen oxide (NOx), hydrocarbon (HC), sulfur oxide (SOx), and particulates.
- Never use the engine in poorly ventilated locations such as indoors, inside of tunnels and so on. If indoor operation is unavoidable, provide proper ventilation so that people and cattle will not be affected.

3) PREVENTING BURNS

- Never touch the exhaust silencer, muffler cover or engine body while the engine is running or hot.

4) PRECAUTIONS FOR THE BATTERY

- The battery electrode is essentially dilute sulfuric acid, which injures the human body and damages clothes. Should it touch the body or clothes, immediately wash it away. If it enters your eye, hasten to consult the doctor.
- Never use fire near the battery during charging, which generates hydrogen.
- Charge the battery in a well ventilated place.

5) OTHERS

- Wear safety shoes, working clothes, etc. before servicing the engine.
- Do not service the engine under the influence of alcohol.
- Keep children and pets away from the engine in operation.
- Do not have access to rotary part during operation, which is extremely dangerous.

2. SERIAL NUMBER LOCATION

Engine serial number (E/#) is indicated in the engine nameplate, and is stamped on the crankcase cover. Before ordering service parts, be sure to check serial number and identify necessary parts by nos. (Parts may not have interchangeability as a result of a change in the specification.)

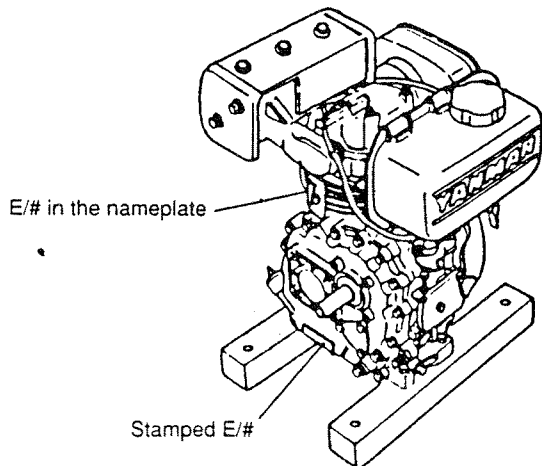

3. SERVICE RULES

1. Use genuine YANMAR parts. Parts that do not meet YANMAR's design specification may damage the engine.
2. In disassembling the engine in trouble, exactly locate the cause of trouble.
Remove or disassemble only the parts specified in the troubleshooting procedure.
3. Use the special tools designed for this engine.
4. Install new gasket, O-ring, cotter pins, etc. when reassembling.
5. When torquing bolts or nuts, tighten them to the specified torque diagonally.
6. Clean parts in cleaning solvent upon disassembly.
Lubricate any sliding surfaces before reassembly.
7. After reassembly, check all parts for proper installation and operation.

CONTENTS

1. Specifications	1
1.1 Specifications	1
1.2 Cross Sectional Views.....	5
2. Service standard	8
3. Disassembly and Reassembly	18
3.1 Tools, Meters and Instruments	18
1. Tools	18
2. Meters, Instruments and Service Accessories	20
3. Instruments	22
3.2 Tightening Torque	23
3.3 Maintenance Schedule.....	24
3.4 Disassembly Procedures	25
3.5 Reassembly Procedures	29
3.6 Recoil Starter	34
4. Checking and Servicing	37
4.1 Cylinder Head	37
4.2 Piston and Piston Pin	41
4.3 Connecting Rod	45
4.4 Crankshaft, Flywheel and Main Bearing	49
4.5 Camshaft and Tappet.....	51
4.6 Timing Gear	52
4.7 Crankcase Cover	53
4.8 Cylinder Sleeve and Cylinder Block.....	55
4.9 Lubrication System.....	56
4.10 Fuel System	58
4.11 Speed Control Device	62
4.12 Electrical System.....	64
1. Wiring Diagram.....	64
2. Starter Motor	69
3. Generator (Dynamo), Regulator and Rectifier	84
4. Air Heater	89
5. Battery	90
4.13 Adjustment	93
5. Troubleshooting	95
6. Test Run	111
7. Helical Inserting Part for Repair	114
Appendix 1 Difference Between Parts under Spec. S and D	117
Appendix 2 Detail of Special Tools	120



1. Specifications

1.1 Specifications

Item	Model	L40AE -				L48AE -			
		D	S	DE	SE	D	S	DE	SE
Type		Single-cylinder, vertical-4 cycle air-cooled diesel							
Cooling system		Forced air cooling by flywheel fan							
Combustion system		Direct injection system							
Starting system		Recoil starter		Starting motor with recoil starter		Recoil starter		Starting motor with recoil starter	
Number of cylinders - Bore × Stroke	mm (in.)	1-68 × 55 (2.677 × 2.165)				1-70 × 55 (2.756 × 2.165)			
Displacement	ℓ (cu.in.)	0.109 (12.14)				0.211 (12.88)			
Output	Continuous	2.8 (3.8)				3.1 (4.2)			
	Maximum	3.1 (4.2)				3.5 (4.7)			
Speed (PTO shaft)	rpm	3600	1800	3600	1800	3600	1800	3600	1800
Speed at no-load, max/min	rpm	$\frac{3800^{+30}}{1200}$	$\frac{1900^{+15}}{600}$	$\frac{3800^{+30}}{1200}$	$\frac{1900^{+15}}{600}$	$\frac{3800^{+30}}{1200}$	$\frac{1900^{+15}}{600}$	$\frac{3800^{+30}}{1200}$	$\frac{1900^{+15}}{600}$
Compression ratio		20.0				19.9			
PTO shaft	PTO position	Crank	Cam	Crank	Cam	Crank	Cam	Crank	Cam
	Direction of revolution	Counterclockwise viewed from PTO shaft							
Fuel oil	Fuel injection pump	Bosch type, YANMAR PFE-M type							
	Fuel injection timing (FID)	bTDC 14 ^{±1}							
	Fuel injection nozzle	Hole nozzle, YANMAR YDLLA-P type							
	Fuel injection pressure	Mpa (kgf/cm ²) 19.6 (200)							
	Fuel oil selection	Diesel fuel BS 2869 A1 or equivalent							
	Fuel oil filter	Paper element, FO tank built-in type							
	Fuel oil tank capacity	ℓ(US gal.)	2.5 (0.66)						
Lubricating oil	Type of lubrication	Forced lubrication via trochoid pump; splash lubrication for valve rocker arm chamber							
	Lubricating oil filter	Resin, 60 mesh							
	Lubricating oil selection	SAE 10W30, API grade CC or higher							
	Lubricating oil capacity	ℓ(US gal.)	0.80 (0.21) effective 0.25 (0.07)						
Air cleaner		Wet type paper element filter (Oil-bath type: Option)							
Exhaust silencer		Expansion silencer with cover							
Governor		All speed type, mechanical							
Engine dimensions (Length × Width × Height)	mm (in.)	D-spec. 332 × 384 × 416 (13.071 × 15.118 × 16.378) S-spec. 324 × 384 × 416 (12.756 × 15.118 × 16.378)							
Dry weight	kg (lb)	25.5 (56.2)		31.0 (68.3)		25.5 (56.2)		31.0 (68.3)	
Permissible angle of inclination	deg.	20 (momentary 30)							
Balancer shaft		Single shaft							

Item		Model	L60AE				L70AE			
			D	S	DE	SE	D	S	DE	SE
Type			Single-cylinder, vertical-4 cycle air-cooled diesel							
Cooling system			Forced air cooling by flywheel fan							
Combustion system			Direct injection system							
Starting system			Recoil starter		Starting motor with recoil starter		Recoil starter		Starting motor with recoil starter	
Number of cylinders - Bore x Stroke		mm (in.)	1-75 x 62 (2.953 x 2.441)				1-78 x 62 (3.071 x 2.441)			
Displacement		ℓ (cu.in.)	0.273 (16.66)				0.296 (18.06)			
Output	Continuous	kW (HP)	4.0 (5.5)				4.4 (6.0)			
	Maximum		4.4 (6.0)				4.9 (6.7)			
Speed (PTO shaft)		rpm	3600	1800	3600	1800	3600	1800	3600	1800
Speed at no-load, max/min		rpm	$\frac{3800^{+30}}{1200}$	$\frac{1900^{+15}}{600}$	$\frac{3800^{+30}}{1200}$	$\frac{1900^{+15}}{600}$	$\frac{3800^{+30}}{1200}$	$\frac{1900^{+15}}{600}$	$\frac{3800^{+30}}{1200}$	$\frac{1900^{+15}}{600}$
Compression ratio			19.5							
PTO shaft	PTO position		Crank	Cam	Crank	Cam	Crank	Cam	Crank	Cam
	Direction of revolution		Counterclockwise viewed from PTO shaft							
Fuel oil	Fuel injection pump		Bosch type, YANMAR PFE-M type							
	Fuel injection timing (FID)	bTDC	14 \pm 1							
	Fuel injection nozzle		Hole nozzle, YANMAR YDLLA-P type							
	Fuel injection pressure	Mpa (kgf/cm 2)	19.6 (200)							
	Fuel oil selection		Diesel fuel BS 2869 A1 or equivalent							
	Fuel oil filter		Paper element, FO tank built-in type							
	Fuel oil tank capacity	ℓ (US gal.)	3.5 (0.92)							
Lubricating oil	Type of lubrication		Forced lubrication via trochoid pump; splash lubrication for valve rocker arm chamber							
	Lubricating oil filter		Resin, 60 mesh							
	Lubricating oil selection		SAE 10W30, API grade CC or higher							
	Lubricating oil capacity	ℓ (US gal.)	1.1 (0.29) effective 0.4 (0.11)							
Air cleaner			Wet type paper element filter (Oil-bath type: Option)							
Exhaust silencer			Expansion silencer with cover							
Governor			All speed type, mechanical							
Engine dimensions (Length x Width x Height)		mm (in.)	D-spec. 383 x 421 x 450 (15.079 x 16.575 x 17.717) S-spec. 358 x 421 x 450 (14.094 x 16.575 x 17.717)							
Dry weight		kg (lb)	33.5 (73.9)		39.0 (86.0)		33.5 (73.9)		39.0 (86.0)	
Permissible angle of inclination		deg.	20 (momentary 30)							
Balancer shaft			Single shaft							

Specifications

Item		Model	L75AE-				L90AE-			
			D	S	DE	SE	D	S	DE	SE
Type			Single-cylinder, vertical-4 cycle air-cooled diesel							
Cooling system			Forced air cooling by flywheel fan							
Combustion system			Direct injection system							
Starting system			Recoil starter		Starting motor with recoil starter		Recoil starter		Starting motor with recoil starter	
Number of cylinders - Bore × Stroke		mm (in.)	1-80 × 70 (3.150 × 2.756)				1-84 × 70 (3.307 × 2.756)			
Displacement		ℓ (cu.in.)	0.351 (21.42)				0.387 (23.62)			
Output	Continuous	kW (HP)	4.8 (6.5)				5.9 (8.0)			
	Maximum		5.5 (7.5)				6.6 (9.0)			
Speed (PTO shaft)		rpm	3600	1800	3600	1800	3600	1800	3600	1800
Speed at no-load, max/min		rpm	$\frac{3800^{+30}}{1200}$	$\frac{1900^{+15}}{600}$	$\frac{3800^{+30}}{1200}$	$\frac{1900^{+15}}{600}$	$\frac{3800^{+30}}{1200}$	$\frac{1900^{+15}}{600}$	$\frac{3800^{+30}}{1200}$	$\frac{1900^{+15}}{600}$
Compression ratio			20.2				18.9			
PTO shaft	PTO position		Crank	Cam	Crank	Cam	Crank	Cam	Crank	Cam
	Direction of revolution		Counterclockwise viewed from PTO shaft							
Fuel oil	Fuel injection pump		Bosch type, YANMAR PFE-M type							
	Fuel injection timing (FID)	bTDC	13 ^{±1}							
	Fuel injection nozzle		Hole nozzle, YANMAR YDLLA-P type							
	Fuel injection pressure	Mpa (kgf/cm ²)	19.6 (200)							
	Fuel oil selection		Diesel fuel BS 2869 A1 or equivalent							
	Fuel oil filter		Paper element, FO tank built-in type							
	Fuel oil tank capacity	ℓ (US gal.)	5.5 (1.45)							
Lubricating oil	Type of lubrication		Forced lubrication via trochoid pump; splash lubrication for valve rocker arm chamber							
	Lubricating oil filter		Resin, 60 mesh							
	Lubricating oil selection		SAE 10W30, API grade CC or higher							
	Lubricating oil capacity	ℓ (US gal.)	1.65 (0.44) effective 0.6 (0.16)							
Air cleaner			Wet type paper element filter (Oil-bath type: Option)							
Exhaust silencer			Expansion silencer with cover							
Governor			All speed type, mechanical							
Engine dimensions (Length × Width × Height)		mm (in.)	D-spec. 417 × 470 × 494 (16.417 × 18.503 × 19.449) S-spec. 392 × 470 × 494 (15.433 × 18.503 × 19.449)							
Dry weight		kg (lb)	48.5 (106.9)		54.0 (119.0)		48.5 (106.9)		54.0 (119.0)	
Permissible angle of inclination		deg.	20 (momentary 30)							
Balancer shaft			Single shaft							

Item		Model	L100AE--			
			D	S	DE	SE
Type			Single-cylinder, vertical-4 cycle air-cooled diesel			
Cooling system			Forced air cooling by flywheel fan			
Combustion system			Direct injection system			
Starting system			Recoil starter		Starting motor with recoil starter	
Number of cylinders - Bore × Stroke		mm (in.)	1-86 × 70 (3.386 × 2.756)			
Displacement		ℓ (cu.in.)	0.406 (24.78)			
Output	Continuous	kW (HP)	6.6 (9.0)			
	Maximum		7.4 (10.0)			
Speed (PTO shaft)		rpm	3600	1800	3600	1800
Speed at no-load, max/min		rpm	3800 ⁺³⁰ 1200	1900 ⁺¹⁵ 600	3800 ⁺³⁰ 1200	1900 ⁺¹⁵ 600
Compression ratio			19.3			
PTO shaft	PTO position		Crank	Cam	Crank	Cam
	Direction of revolution		Counterclockwise viewed from PTO shaft			
Fuel oil	Fuel injection pump		Bosch type, YANMAR PFE-M type			
	Fuel injection timing (FID)	bTDC	13 ⁺¹			
	Fuel injection nozzle		Hole nozzle, YANMAR YDLLA-P type			
	Fuel injection pressure	Mpa (kgf/cm ²)	19.6 (200)			
	Fuel oil selection		Diesel fuel BS 2869 A1 or equivalent			
	Fuel oil filter		Paper element, FO tank built-in type			
	Fuel oil tank capacity	ℓ (US gal.)	5.5 (1.45)			
Lubricating oil	Type of lubrication		Forced lubrication via trochoid pump; splash lubrication for valve rocker arm chamber			
	Lubricating oil filter		Resin, 60 mesh			
	Lubricating oil selection		SAE 10W30, API grade CC or higher			
	Lubricating oil capacity	ℓ (US gal.)	1.65 (0.44) effective 0.6 (0.16)			
Air cleaner			Wet type paper element filter (Oil-bath type: Option)			
Exhaust silencer			Expansion silencer with cover			
Governor			All speed type, mechanical			
Engine dimensions (Length × Width × Height)		mm (in.)	D-spec. 417 × 470 × 494 (16.417 × 18.504 × 19.449) S-spec. 392 × 470 × 494 (15.433 × 18.503 × 19.449)			
Dry weight		kg (lb)	48.5 (106.9)		54.0 (119.0)	
Permissible angle of inclination		deg.	20 (momentary 30)			
Balancer shaft			Single shaft			

1.2 Cross Sectional Views

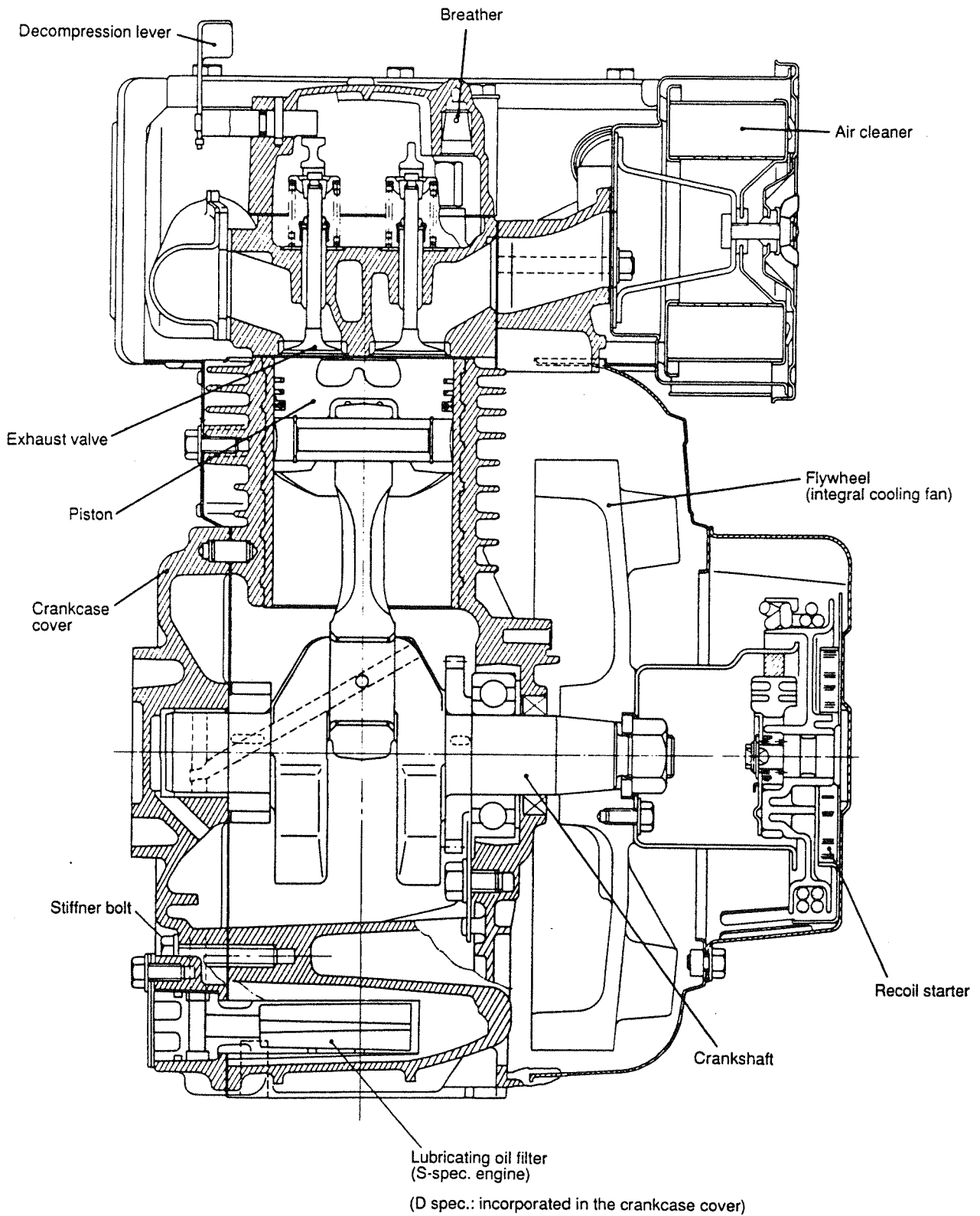

Longitudinal sectional view

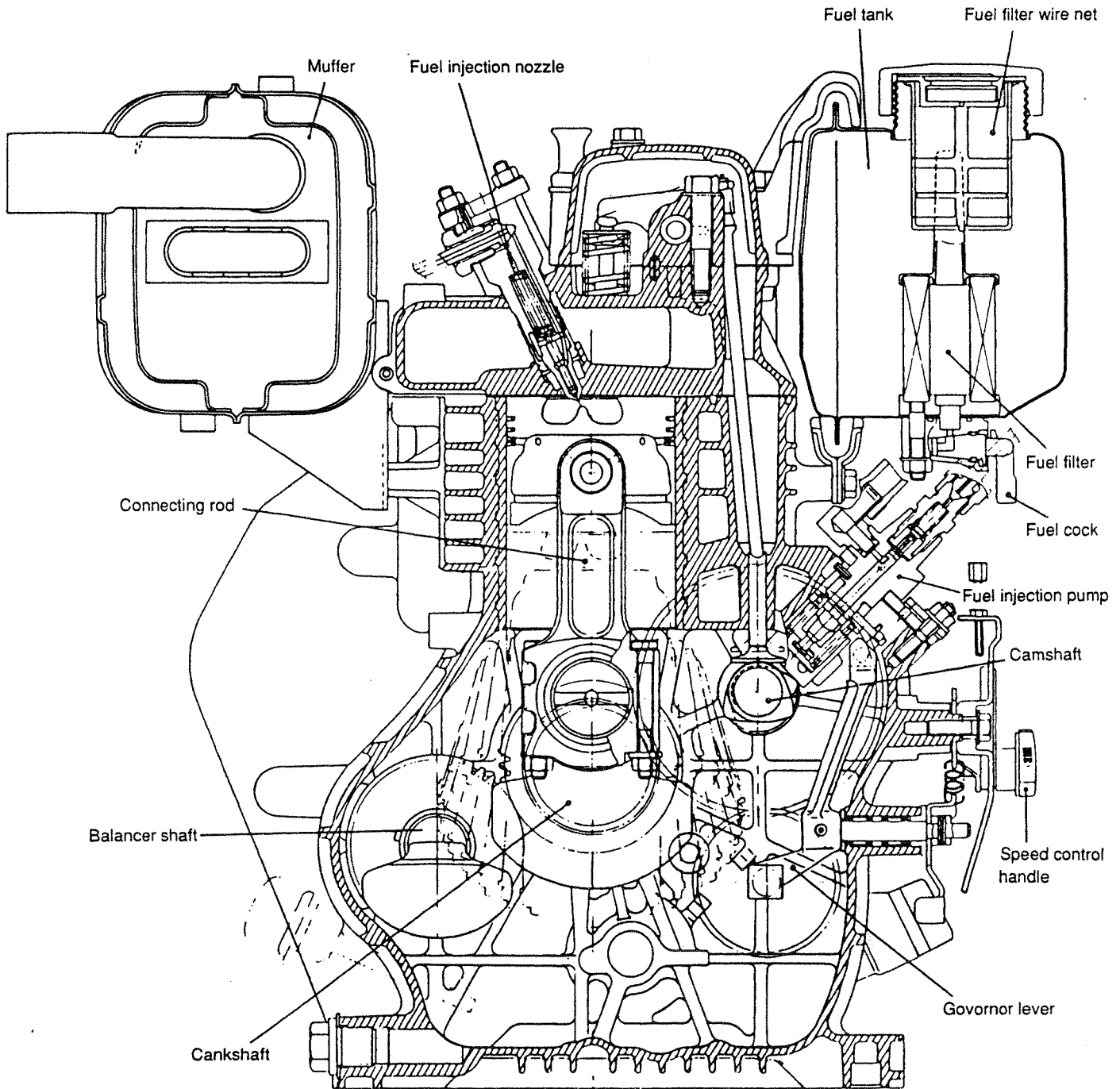

Plan view

Camshaft P.T.O.

(S spec.)

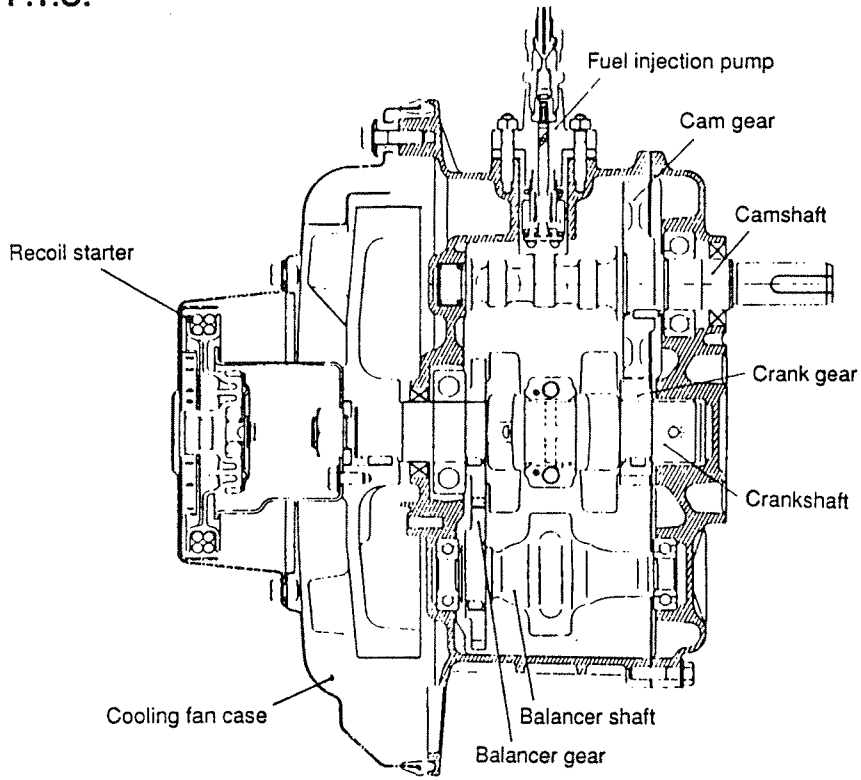

Crankshaft P.T.O.

(D spec.)

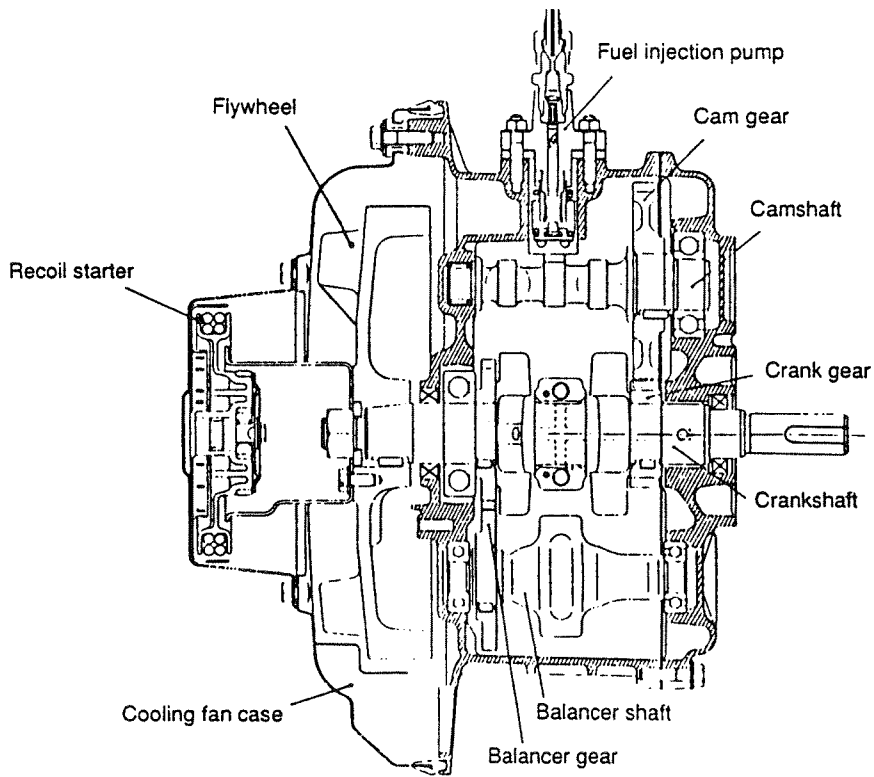

2. Service Standards

Unit: mm (in.)

Parts	Model	Standard	Service limit	Remarks
-------	-------	----------	---------------	---------

Intake/exhaust valve seats

Seat angle	L40AE~ L100AE	60°–90°	—	
Seat width	L40AE~ L100AE	1.5–3.0 (0.059–0.118)	—	

Intake/exhaust valves & valve guides

Valve sinkage	L40AE~ L100AE	0.3–0.7 (0.012–0.028)	1.1 (0.043)	
Valve guide I.D.	Intake/ Exhaust	L40AE, L48AE	5.500–5.515 (0.2165–0.2171)	5.58 (0.2197)
		L60AE, L70AE	6.0–6.015 (0.2362–0.2368)	6.08 (0.2394)
		L75AE~ L100AE	7.0–7.015 (0.2756–0.2762)	7.08 (0.2787)
Valve stem O.D.	Intake	L40AE, L48AE	5.465–5.475 (0.2152–0.2156)	5.40 (0.2126)
		L60AE, L70AE	5.960–5.975 (0.2346–0.2352)	5.90 (0.2323)
		L75AE~ L100AE	6.960–6.975 (0.2740–0.2745)	6.90 (0.2717)
	Exhaust	L40AE, L48AE	5.450–5.460 (0.2146–0.2150)	5.40 (0.2126)
		L60AE, L70AE	5.945–5.960 (0.2341–0.2346)	5.90 (0.2323)
		L75AE~ L100AE	6.945–6.960 (2.734–2.740)	6.90 (0.2717)

Valve spring

Free length	L40AE, L48AE	28 (1.102)	26.5 (1.043)	
	L60AE, L70AE	33 (1.299)	31.5 (1.240)	
	L75AE~ L100AE	40 (1.575)	39.5 (1.555)	

Service Standards

Unit: mm (in.)

Parts	Model	Standard	Service limit	Remarks
Valve spring				
Inclination	L40AE, L48AE	<0.75 (0.030)	—	
	L60AE, L70AE	<0.6 (0.024)	—	
	L75AE~ L100AE	<1.0 (0.039)	—	
Spring constant (kg/mm)	L40AE, L48AE	1.14~1.4kg (2.51~3.09 lb)	—	
	L60AE, L70AE	1.27~1.55kg (2.80~3.42 lb)	—	
	L75AE~ L100AE	1.80~2.51kg (3.97~5.51 lb)	—	

Intake/exhaust valve rocker-arm, rocker shaft and push rods

IN/EX valve rocker arm shaft O.D.	L40AE~ L70AE	11.989~12.000 (0.4720~0.4724)	11.90 (0.4685)	
	L75AE~ L100AE	14.989~15.000 (0.5901~0.5906)	14.90 (0.5866)	
IN/EX valve rocker arm I.D.	L40AE~ L70AE	12.016~12.034 (0.4731~0.4738)	12.10 (0.4764)	
	L75AE~ L100AE	15.016~15.034 (0.5912~0.5919)	15.10 (0.5945)	
Push rod length	L40AE~ L48AE	129.8~130.2 (5.110~5.126)	—	
	L60AE~ L70AE	162.3~162.7 (6.390~6.406)	—	
	L75AE~ L100AE	196.8~197.2 (7.748~7.764)	—	
Push rod distortion	L40AE~ L100AE	< 0.05 (0.0020)	0.3 (0.0118)	

Valve clearance

Intake and exhaust	L40AE~ L100AE	0.15 (0.0059)	—	
--------------------	------------------	------------------	---	--

Unit: mm (in.)

Parts	Model	Standard	Service limit	Remarks
Valve opening/closing timing				
Intake	Open	L40AE~ L70AE	25° b T.D.C.	—
		L75AE~ L100AE	20° b T.D.C.	—
	Closed	L40AE~ L70AE	59° a B.D.C.	—
		L75AE~ L100AE	53° a B.D.C.	—
Exhaust	Open	L40AE~ L70AE	59° b B.D.C.	—
		L75AE~ L100AE	53° b. B.D.C	—
	Closed	L40AE~ L70AE	25° a T.D.C.	—
		L75AE~ L100AE	20° a T.D.C.	—

Piston

Piston O.D.	L40AE	67.965 (2.6758)	67.68 (2.6646)	Refer to Page 31 for measuring position. Oversize: 0.25 mm 0.50 mm
	L48AE	69.965 (2.7545)	69.70 (2.7441)	
	L60AE	74.965 (2.9514)	74.70 (2.9410)	
	L70AE	79.965 (3.1482)	77.70 (3.0590)	
	L75AE	79.965 (3.1482)	79.70 (3.1378)	
	L90AE	83.965 (3.3057)	83.70 (3.2953)	
	L100AE	85.965 (3.3844)	85.70 (3.3740)	
Clearance between piston and sleeve	L40AE~ L90AE	0.04–0.06 (0.00157–0.00236)	—	
	L100AE	0.05–0.07 (0.00197–0.00276)	—	
Piston pin hole ID	L40AE/ L48AE	18.985–18.996 (0.7474–0.7479)	19.07 (0.7508)	
	L60AE/ L70AE	20.983–20.996 (0.8261–0.8266)	21.07 (0.8295)	
	L75AE~ L100AE	22.983–22.996 (0.9048–0.9054)	23.07 (0.9083)	
Clearance between piston pin hole and piston pin	L40AE	L 0.004–0.015 T (0.0002–0.0006)	—	L: Loose fit T: Tight fit
	L48AE~ L100AE	L 0.005–0.017 T (0.0002–0.0007)	—	

Parts	Model	Standard	Service limit	Remarks
Piston pin				
Piston pin O.D.	L40AE, L48AE	18.992–19.000 (0.7477–0.7480)	18.92 (0.7449)	
	L60AE, L70AE	20.991–21.000 (0.8264–0.8268)	20.91 (0.8232)	
	L75AE~ L100AE	22.991–23.000 (0.9052–0.9055)	22.91 (0.9020)	

Piston and rings

1st ring side clearance (ring width and ring groove)	L40AE~ L100AE	0.065–0.095 (0.0026–0.0037)	0.15 (0.0059)	
2nd ring side clearance (ring width and ring groove)	L40AE~ L100AE	0.03–0.065 (0.0012–0.0026)	0.15 (0.0059)	
Oil ring side clearance (ring width and ring groove)	L40AE~ L100AE	0.02–0.055 (0.0008–0.0022)	0.15 (0.0059)	

Piston ring

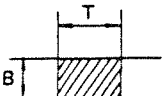
1st ring	T dimensions	L40AE	2.7–2.9 (0.1063–0.1141)	2.52 (0.0992)	
		L48AE	3.0–3.2 (0.1181–0.1260)	2.77 (0.1091)	
		L60AE~ L70AE	3.2–3.4 (0.1260–0.1339)	2.97 (0.1169)	
		L75AE	3.3–3.5 (0.1299–0.1378)	3.07 (0.1209)	
		L90AE	3.4–3.6 (0.1339–0.1417)	3.17 (0.1248)	
		L100AE	3.6–3.8 (0.1417–0.1496)	3.37 (0.1327)	
	B dimensions	L40AE~ L100AE	1.470–1.485 (0.0579–0.0585)	1.36 (0.0535)	
2nd ring	T dimensions	L40AE	2.75–2.95 (0.1083–0.1161)	2.75 (0.1083)	
		L48AE	3.0–3.2 (0.1181–0.1260)	2.77 (0.1091)	
		L60AE/ L70AE	3.2–3.4 (0.1260–0.1339)	2.97 (0.1169)	
		L75AE	3.3–3.5 (0.1300–0.1378)	3.07 (0.1209)	
		L90AE	3.4–3.6 (0.1339–0.1417)	3.17 (0.1248)	
		L100AE	3.6–3.8 (0.1417–0.1496)	3.37 (0.1327)	
	B dimensions	L40AE~ L70AE	1.470–1.490 (0.0579–0.0587)	1.36 (0.0535)	
		L75AE~ L100AE	1.970–1.990 (0.0776–0.0783)	1.86 (0.0732)	

Unit: mm (in.)

Parts	Model	Standard	Service limit	Remarks	
Piston ring					
Oil ring	T dimensions	L40AE	2.6-2.8 (0.1024-0.1102)	2.49 (0.0980)	
		L48AE	2.0-2.4 (0.0787-0.0945)	1.99 (0.0783)	
		L60AE/ L70AE	2.1-2.5 (0.0827-0.0984)	2.07 (0.0815)	
		L75AE	2.4-2.8 (0.0945-0.1102)	2.37 (0.0933)	
		L90AE/ L100AE	2.5-2.9 (0.0984-0.1141)	2.47 (0.0972)	
	B dimensions	L40AE~ L70AE	3.470-3.490 (0.1366-0.1374)	3.36 (0.1323)	
		L75AE~ L100AE	3.970-3.990 (0.1563-0.1571)	3.86 (0.1520)	
End gap	1st ring	L40AE~ L100AE	0.20-0.35 (0.0078-0.0138)	1.0 (0.0394)	
	2nd ring	L40AE~ L100AE	0.30-0.45 (0.0118-0.0177)	1.0 (0.0394)	
	Oil ring	L40AE~ L100AE	0.15 - 0.35 (0.0059 - 0.0138)	1.0 (0.0394)	

Connecting rod

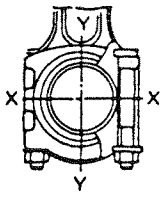
Small end hole (piston pin)	ID	L40AE, L48AE	19.012-19.024 (0.7485-0.7490)	19.10 (0.7520)	
		L60AE, L70AE	21.014-21.028 (0.8273-0.8279)	21.10 (0.8307)	
		L75AE~ L100AE	23.025-23.038 (0.9065-0.9070)	23.10 (0.9094)	
	Oil clearance	L40AE, L48AE	0.015-0.030 (0.0006-0.0012)	—	
		L60AE, L70AE	0.017-0.034 (0.0007-0.0013)	—	
		L75AE~ L100AE	0.028-0.044 (0.0011-0.0017)	—	
Large end hole (Crank pin)	ID (Y-Y direction)	L40AE, L48AE	30.007-30.015 (1.1814-1.1817)	30.09 (1.1846)	
		L60AE, L70AE	36.007-36.015 (1.4176-1.4179)	36.09 (1.4209)	
		L75AE~ L100AE	40.000-40.042 (1.5748-1.5765)	40.08 (1.5780)	
	Oil clearance	L40AE~ L70AE	0.025-0.050 (0.0010-0.0020)	—	
		L75AE~ L100AE	0.033-0.062 (0.0013-0.0024)	—	

Parts		Model	Standard	Service limit	Remarks	
Crankshaft and Main bearing						
Crank pin	Pin O.D.	L40AE, L48AE	29.965-29.982 (1.1797-1.1804)	29.90 (1.1772)		
		L60AE, L70AE	35.965-35.982 (1.4159-1.4166)	35.90 (1.4134)		
		L75AE~L100AE	39.965-39.982 (1.5734-1.5741)	39.90 (1.5709)		
	Oil clearance	L40AE~L70AE	0.025-0.055 (0.0010-0.0022)	—		
		L75AE~L100AE	0.033-0.062 (0.0013-0.0024)			
Crank journal part	Gear cover side	L40AE, L48AE	30.002-30.015 (1.1812-1.1817)	29.91 (1.1776)		
		L60AE, L70AE	35.002-35.018 (1.3780-1.3787)	34.91 (1.3744)		
		L75AE~L100AE	40.002-40.018 (1.5749-1.5755)	39.91 (1.5713)		
	Oil clearance	L40AE, L48AE	0.025-0.058 (0.0010-0.0023)	0.17 (0.0067)		
		L60AE~L100AE	0.025-0.061 (0.0010-0.0024)			
	Flywheel side	Journal O.D.	L40AE, L48AE	30.002-30.015 (1.1812-1.1817)	—	
			L60AE, L70AE	35.007-35.018 (1.3782-1.3787)	—	
			L75AE~L100AE	40.007-40.018 (1.5751-1.5755)	—	
	Journal part	Flywheel side	Bearing I.D.	L40AE, L48AE	29.990-30.000 (1.1807-1.1811)	—
L60AE, L70AE				34.988-35.000 (1.3775-1.3780)	—	
L75AE~L100AE				39.988-40.000 (1.5743-1.5748)	—	
Fitting		L40AE, L48AE	0.002-0.025 (0.00008-0.0010)	—	Tight fit	
		L60AE, L70AE	0.007-0.030 (0.0003-0.0012)	—		
		L75AE~L100AE				

Unit: mm (in.)

Parts	Model	Standard	Service limit	Remarks	
Camshaft					
Needle bearing on cylinder block side	Shaft O.D.	L40AE~L100AE	14.989–15.000 (0.5901–0.5906)	14.92 (0.5874)	
	Bearing I.D.	L40AE~L100AE	15.016–15.034 (0.5912–0.5919)	—	
	Oil clearance	L40AE~L100AE	0.016–0.045 (0.0006–0.0018)	—	
Ball bearing on crankcase cover side	Stem O.D.	L40AE, L48AE	24.980–24.993 (0.9835–0.9840)	24.90 (0.9803)	
		L60AE, L70AE	29.980–29.993 (1.1803–1.1808)	29.90 (1.1772)	
		L75AE~L100AE	34.980–34.993 (1.3772–1.3777)	34.90 (1.3740)	
Ball bearing on crankcase cover side	Bearing I.D.	L40AE, L48AE	24.990–25.000 (0.9839–0.9843)	25.02 (0.9850)	
		L60AE, L70AE	29.990–30.000 (1.1807–1.1811)	30.02 (1.1819)	
		L75AE~L100AE	34.990–35.000 (1.3776–1.3780)	35.02 (1.3787)	
	Oil clearance	L40AE, L48AE	L 0.020–0.030 T (0.0008–0.0012)	0.08–0.10 (0.0031–0.0039)	L: Loose fit T: Tight fit
		L60AE, L70AE			
		L75AE~L100AE			
Thrust clearance (Gap of axial direction)	L40AE~L100AE	0.040–0.280 (0.0016–0.0110)	0.45 (0.0177)		

Tappet

Tappets for IN/ EX. valves	Stem O.D.	L40AE~L100AE	6.960–6.980 (0.2740–0.2748)	6.87 (0.2705)	
	Hole dia. (Cylinder block)	L40AE~L100AE	7.000–7.015 (0.2756–0.2762)	7.06 (0.2780)	
	Oil clearance	L40AE~L100AE	0.020–0.055 (0.0008–0.0022)	—	
Tappets for fuel injection pump	O.D.	L40AE~L100AE	23.972–23.993 (0.9438–0.9446)	23.89 (0.9405)	
	Hole dia. (Cylinder block)	L40AE~L100AE	24.000–24.033 (0.9449–0.9462)	24.06 (0.9472)	
	Oil clearance	L40AE~L100AE	0.007–0.061 (0.0003–0.0024)	—	

Parts	Model	Standard	Service limit	Remarks	
Crankcase cover					
Crankshaft bearing part	I.D.	L40AE, L48AE	34.000-34.025 (1.3386-1.3396)	—	
		L60AE, L70AE	39.000-39.025 (1.5354-1.5364)	—	
		L75AE~L100AE	44.000-44.025 (1.7323-1.7333)	—	
	Bearing O.D (Plain)	L40AE, L48AE	34.070-34.105 (1.3413-1.3427)	—	
		L60AE, L70AE	39.070-39.105 (1.5382-1.5396)	—	
		L75AE L100AE	44.085-44.120 (1.7356-1.7370)	—	
	Fitting	L40AE~L70AE	0.045-0.105 (0.0018-0.0041)	—	Tight fit
		L75AE~L100AE	0.060-0.120 (0.0024-0.0047)	—	
	Bearing metal I.D. (Plain metal)	L40AE, L48AE	30 (1.1811)	30.13 (1.1862)	
		L60AE, L70AE	35 (1.3780)	35.13 (1.3831)	
		L75AE~L100AE	40 (1.5748)	40.13 (1.5800)	
	Camshaft bearing part	I.D.	L40AE~L48AE	51.945-51.965 (2.0451-2.0455)	—
L60AE, L70AE			61.940-61.960 (2.4386-2.4394)	—	
L75AE~L100AE			71.935-71.955 (2.8321-2.8329)	—	
Ball bearing O.D.		L40AE, L48AE	51.987-52.000 (2.0467-2.0472)	—	Tight fit
		L60AE~L70AE	61.987-62.000 (2.4404-2.4409)	—	
		L75AE~L100AE	71.987-72.000 (2.8341-2.8346)	—	
Fitting		L40AE, L48AE	0.022-0.055 (0.0009-0.0022)	—	
		L60AE, L70AE	0.027-0.060 (0.0011-0.0024)	—	
		L75AE~L100AE	0.032-0.065 (0.0013-0.0026)	—	

Unit: mm (in.)

Parts	Model	Standard	Service limit	Remarks	
Cylinder block					
Crankshaft bearing part	I.D.	L40AE, L48AE	71.9905–72.0095 (2.8343–2.8350)	—	
		L60AE, L70AE	79.980–79.996 (3.1488–3.1494)	—	
		L75AE~L100AE	89.984–90.000 (3.5427–3.5433)	—	
	Ball bearing O.D.	L40AE, L48AE	71.987–72.000 (2.8341–2.8346)	—	
		L60AE, L70AE	79.987–80.000 (3.1491–3.1496)	—	
		L75AE~L100AE	89.985–90.000 (3.5427–3.5433)	—	
	Fitting	L40AE, L48AE	0.0225–0.0095 (0.00089–0.00037)	—	
		L60AE, L70AE	0.009–0.020 (0.00035–0.00079)	—	
		L75AE, L100AE	0.015–0.016 (0.00059–0.00063)	—	
Camshaft bearing part	I.D.	L40AE, L100AE	20.957–20.978 (0.8251–0.8259)	—	
Cylinder sleeve I.D.	L40AE	68.000–68.030 (2.6771–2.6783)	68.16 (2.6835)		
	L48AE	70.000–70.030 (2.7559–2.7571)	70.16 (2.7622)		
	L60AE	75.000–75.030 (2.9528–2.9539)	75.18 (2.9598)		
	L70AE	78.000–78.030 (3.0709–3.0720)	78.18 (3.0779)		
	L75AE	80.000–80.030 (3.1496–3.1509)	80.18 (3.1567)		
	L90AE	84.000–84.030 (3.3071–3.3083)	84.18 (3.3142)		
	L100AE	86.000–86.030 (3.3858–3.3870)	86.18 (3.3929)		

Service Standards

Unit: mm (in.)



Parts	Model	Standard	Service limit	Remarks
Oil pump (Trochoid pump)				
Outer	Outer rotor O.D.	L40AE~ L100AE	28.96–28.98 (1.1402–1.1409)	28.90 (1.1378)
	Housing I.D. (Crankcase over)	L40AE~ L100AE	29.100–29.121 (1.1457–1.1465)	29.18 (1.1488)
	Clearance between housing ID and outer rotor O.D.	L40AE~ L100AE	0.120–0.161 (0.0047–0.0063)	—
Width	Outer and Inner rotor width	L40AE~ L100AE	7.97–8.00 (0.3138–0.3150)	7.90 (0.3110)
	Housing depth	L40AE~ L100AE	8.02–8.05 (0.3157–0.3169)	8.10 (0.3189)
	Clearance between housing and inner/outer rotors	L40AE~ L100AE	0.02–0.08 (0.0008–0.0031)	—
Clearance between the inner and outer rotor	L40AE~ L100AE	<0.14 (0.0055)	0.25 (0.0098)	
Cylinder compression pressure at 3000 rpm engine speed (turn the starter motor)	L40AE~ L100AE	2942 kPa (30 kgf/cm ²) [427 psi]	2452 kPa (25 kgf/cm ²) [356 psi]	
Cylinder compression pressure at 500 rpm engine speed (pull the recoil starter)	L40AE~ L100AE	2452 kPa (25 kgf/cm ²) [356 psi]	1961 kPa (20 kgf/cm ²) [284 psi]	

3. Disassembly and Reassembly

3.1 TOOLS, METERS AND INSTRUMENTS

Keep the following tools, jigs, and other service items on hand to ensure accurate measurement and diagnosis and efficient servicing.

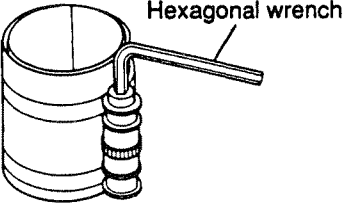
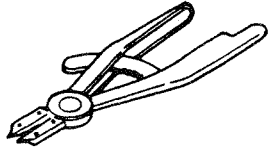
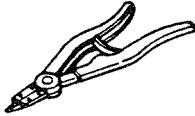
1. Tools

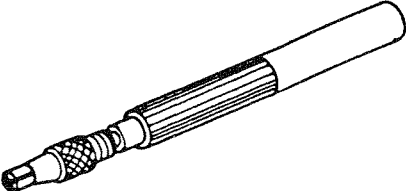
Name of tool	Description (YANMAR Code No.)	Illustration
YANMAR service tool set	Type A (including 65 tools) (955000-00001) Type B (including 46 tools) (955000-00002)	
Piston inserting tool	Commercially available (955500-02476) For ϕ 60 – 125	 Hexagonal wrench
Bore Pliers	(28190-000130) (included in YANMAR service tool set)	
Shaft pliers	(28190-000020) (included in YANMAR service tool set)	
Piston ring remover	(135410-92140)	
Cleaning needle for fuel injection valve	Wire (use ϕ 0.19) Commercially available	
	Pinvise Commercially available (28210-000010)	

Disassembly and Reassembly

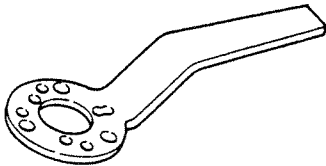
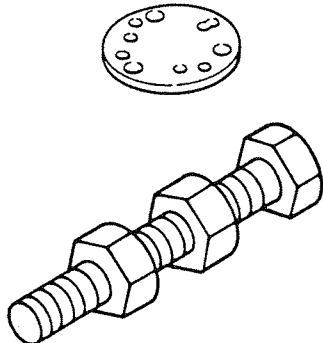
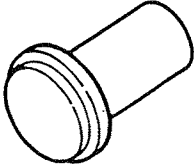
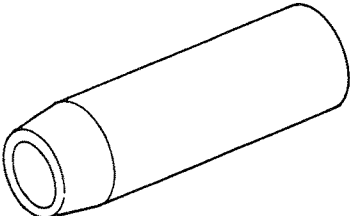
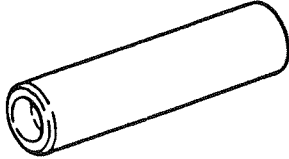

Name of tool	Description (YANMAR Code No.)	Illustration															
Flywheel end nut wrench*	Special-purpose tool for tightening the crankshaft end nut. (114250-92101)																
Flywheel extractor*	(114250-92121) <table border="1" data-bbox="508 428 1096 554"> <thead> <tr> <th>Model</th> <th>Bolt</th> <th>pcs</th> <th>Nut</th> <th>pcs</th> </tr> </thead> <tbody> <tr> <td>L40AE – L70AE</td> <td>26116-060454</td> <td>3</td> <td>26716-060002</td> <td>6</td> </tr> <tr> <td>L75AE – L100AE</td> <td>"</td> <td>4</td> <td>"</td> <td>8</td> </tr> </tbody> </table>	Model	Bolt	pcs	Nut	pcs	L40AE – L70AE	26116-060454	3	26716-060002	6	L75AE – L100AE	"	4	"	8	
Model	Bolt	pcs	Nut	pcs													
L40AE – L70AE	26116-060454	3	26716-060002	6													
L75AE – L100AE	"	4	"	8													
Oil seal fitting tool*	<table border="1" data-bbox="508 764 1096 982"> <thead> <tr> <th rowspan="2">Code</th> <th colspan="2">Applicable part</th> </tr> <tr> <th>Cylinder block (Crankshaft)</th> <th>Sidecover (Crank & Cam shaft)</th> </tr> </thead> <tbody> <tr> <td>114250-92311</td> <td>—</td> <td>L40AE, L48AE</td> </tr> <tr> <td>114350-92311</td> <td>L40AE ~ L70AE</td> <td>L60AE, L70AE</td> </tr> <tr> <td>114650-92310</td> <td colspan="2">L75AE ~ L100AE</td> </tr> </tbody> </table>	Code	Applicable part		Cylinder block (Crankshaft)	Sidecover (Crank & Cam shaft)	114250-92311	—	L40AE, L48AE	114350-92311	L40AE ~ L70AE	L60AE, L70AE	114650-92310	L75AE ~ L100AE			
Code	Applicable part																
	Cylinder block (Crankshaft)	Sidecover (Crank & Cam shaft)															
114250-92311	—	L40AE, L48AE															
114350-92311	L40AE ~ L70AE	L60AE, L70AE															
114650-92310	L75AE ~ L100AE																
Oil seal fitting guide*	After insertion of seal into crankcase cover, use this tool to install crankcase cover on cylinder block. Jig for inserting crankshaft and camshaft oil seals <table border="1" data-bbox="508 1234 1096 1512"> <thead> <tr> <th>Code</th> <th>Applicable Model</th> </tr> </thead> <tbody> <tr> <td>114250-92301</td> <td>L40AE-S, L48AE-S, L40AE-D, L48AE-D</td> </tr> <tr> <td>114268-92300</td> <td>L40AE-DE, L48AE-DE</td> </tr> <tr> <td>114350-92301</td> <td>L60AE-S, L70AE-S, L60AE-D, L70AE-D</td> </tr> <tr> <td>114368-92300</td> <td>L60AE-DE, L70AE-DE</td> </tr> <tr> <td>114650-92300</td> <td>L75AE-S, L90AE-S, L100AE-S</td> </tr> <tr> <td>114668-92300</td> <td>L75AE-DE, L90AE-DE, L100AE-DE</td> </tr> </tbody> </table>	Code	Applicable Model	114250-92301	L40AE-S, L48AE-S, L40AE-D, L48AE-D	114268-92300	L40AE-DE, L48AE-DE	114350-92301	L60AE-S, L70AE-S, L60AE-D, L70AE-D	114368-92300	L60AE-DE, L70AE-DE	114650-92300	L75AE-S, L90AE-S, L100AE-S	114668-92300	L75AE-DE, L90AE-DE, L100AE-DE		
Code	Applicable Model																
114250-92301	L40AE-S, L48AE-S, L40AE-D, L48AE-D																
114268-92300	L40AE-DE, L48AE-DE																
114350-92301	L60AE-S, L70AE-S, L60AE-D, L70AE-D																
114368-92300	L60AE-DE, L70AE-DE																
114650-92300	L75AE-S, L90AE-S, L100AE-S																
114668-92300	L75AE-DE, L90AE-DE, L100AE-DE																
Valve stem seal fitting tool*	<table border="1" data-bbox="508 1562 925 1722"> <thead> <tr> <th>Model</th> <th>Code</th> </tr> </thead> <tbody> <tr> <td>L40AE, L48AE</td> <td>114250-92350</td> </tr> <tr> <td>L60AE, L70AE</td> <td>114350-92350</td> </tr> <tr> <td>L75AE-100AE</td> <td>114650-92350</td> </tr> </tbody> </table>	Model	Code	L40AE, L48AE	114250-92350	L60AE, L70AE	114350-92350	L75AE-100AE	114650-92350								
Model	Code																
L40AE, L48AE	114250-92350																
L60AE, L70AE	114350-92350																
L75AE-100AE	114650-92350																

*Dimensions of oil seal fitting tool, oil seal fitting guide, flywheel tightening handle, flywheel extractor and valve stem seal fitting tool are detailed in Appendix 2.

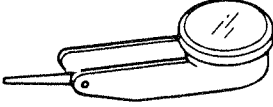

2. Meters, Instruments, and Service Accessories

(Necessary for middle- and small-size engine service shops)

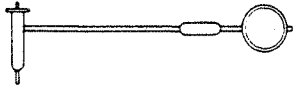
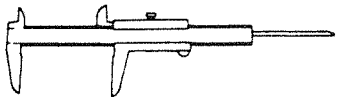
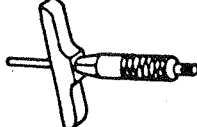
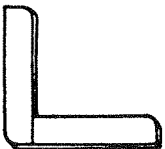
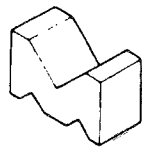
- Typical sizes -

Instrument Name	Description		Illustration											
Dial gauge	<table border="1"> <tr> <td colspan="2">mm (in.)</td> </tr> <tr> <td>1 div.</td> <td>0.01 (0.0004)</td> </tr> <tr> <td>Range</td> <td>0-5 (0-0.197)</td> </tr> <tr> <td></td> <td>0-10 (0-0.394)</td> </tr> </table>		mm (in.)		1 div.	0.01 (0.0004)	Range	0-5 (0-0.197)		0-10 (0-0.394)	To measure bending and gap of the shaft, surface distortion, etc.			
mm (in.)														
1 div.	0.01 (0.0004)													
Range	0-5 (0-0.197)													
	0-10 (0-0.394)													
Test indicator	<table border="1"> <tr> <td colspan="2">mm (in.)</td> </tr> <tr> <td>1 div.</td> <td>0.01 (0.0004)</td> </tr> <tr> <td>Range</td> <td>0-0.8 (0-0.031)</td> </tr> </table>		mm (in.)		1 div.	0.01 (0.0004)	Range	0-0.8 (0-0.031)	To measure positions too narrow and too deep for normal dial indicators.					
mm (in.)														
1 div.	0.01 (0.0004)													
Range	0-0.8 (0-0.031)													
Magnet stand	<table border="1"> <tr> <td colspan="2">mm (in.)</td> </tr> <tr> <td>Main bar (dia. x length)</td> <td>Sub bar (dia. x length)</td> </tr> <tr> <td>12 x 176 (0.472 x 6.929)</td> <td>10 x 165 (0.394 x 6.496)</td> </tr> <tr> <td>14 x 183 (0.551 x 7.205)</td> <td>12 x 165 (0.472 x 6.496)</td> </tr> </table>		mm (in.)		Main bar (dia. x length)	Sub bar (dia. x length)	12 x 176 (0.472 x 6.929)	10 x 165 (0.394 x 6.496)	14 x 183 (0.551 x 7.205)	12 x 165 (0.472 x 6.496)	To attach dial indicators to various positions for easy accurate viewing.			
mm (in.)														
Main bar (dia. x length)	Sub bar (dia. x length)													
12 x 176 (0.472 x 6.929)	10 x 165 (0.394 x 6.496)													
14 x 183 (0.551 x 7.205)	12 x 165 (0.472 x 6.496)													
Micrometer	<table border="1"> <tr> <td>Range</td> <td>mm (in.)</td> </tr> <tr> <td>0-25</td> <td>(0-0.984)</td> </tr> <tr> <td>25-50</td> <td>(0.984-1.969)</td> </tr> <tr> <td>50-75</td> <td>(1.969-2.953)</td> </tr> <tr> <td>75-100</td> <td>(2.953-3.937)</td> </tr> </table>		Range	mm (in.)	0-25	(0-0.984)	25-50	(0.984-1.969)	50-75	(1.969-2.953)	75-100	(2.953-3.937)	To measure the O.D. of the crankshaft, piston, piston pin, etc.	
Range	mm (in.)													
0-25	(0-0.984)													
25-50	(0.984-1.969)													
50-75	(1.969-2.953)													
75-100	(2.953-3.937)													
Cylinder gauge	<table border="1"> <tr> <td>Range</td> <td>mm (in.)</td> </tr> <tr> <td>10-18</td> <td>(0.394-0.709)</td> </tr> <tr> <td>18-35</td> <td>(0.709-1.378)</td> </tr> <tr> <td>35-60</td> <td>(1.378-2.362)</td> </tr> <tr> <td>50-100</td> <td>(1.969-3.937)</td> </tr> </table>		Range	mm (in.)	10-18	(0.394-0.709)	18-35	(0.709-1.378)	35-60	(1.378-2.362)	50-100	(1.969-3.937)	To measure the I.D. of the cylinder liners and bearings.	
Range	mm (in.)													
10-18	(0.394-0.709)													
18-35	(0.709-1.378)													
35-60	(1.378-2.362)													
50-100	(1.969-3.937)													
Vernier calipers	<table border="1"> <tr> <td colspan="2">mm (in.)</td> </tr> <tr> <td>1 div.</td> <td>0.05 (0.002)</td> </tr> <tr> <td>Range</td> <td>0-150 (0-5.906)</td> </tr> </table>		mm (in.)		1 div.	0.05 (0.002)	Range	0-150 (0-5.906)	To measure outside diameter, depth, thickness, width, etc.					
mm (in.)														
1 div.	0.05 (0.002)													
Range	0-150 (0-5.906)													
Depth micrometer	<table border="1"> <tr> <td>Range</td> <td>mm (in.)</td> </tr> <tr> <td>0-25</td> <td>(0-0.984)</td> </tr> </table>		Range	mm (in.)	0-25	(0-0.984)	To measure valve sinkage and liner projection.							
Range	mm (in.)													
0-25	(0-0.984)													
Square	<table border="1"> <tr> <td colspan="2">mm (in.)</td> </tr> <tr> <td>Size</td> <td>100 (3.937)</td> </tr> </table>		mm (in.)		Size	100 (3.937)	To measure the inclination of valve springs and squareness of various parts.							
mm (in.)														
Size	100 (3.937)													
V-block	<table border="1"> <tr> <td colspan="2">mm (in.)</td> </tr> <tr> <td>Size</td> <td>100 x 50 x 55 (3.937 x 1.9685 x 2.165 in.)</td> </tr> </table>		mm (in.)		Size	100 x 50 x 55 (3.937 x 1.9685 x 2.165 in.)	Use when measuring the bending of a shaft.							
mm (in.)														
Size	100 x 50 x 55 (3.937 x 1.9685 x 2.165 in.)													

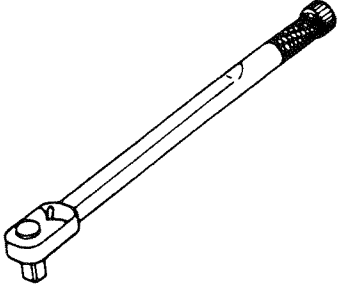
Disassembly and Reassembly

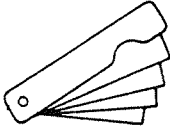
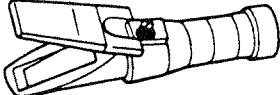
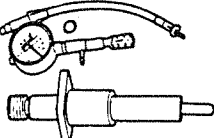
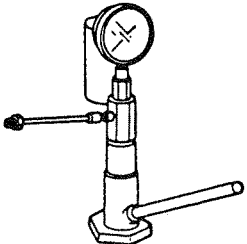
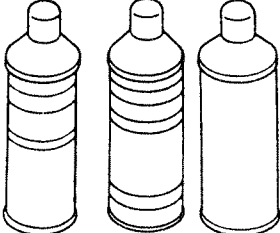
Instrument Name (Yanmar code No.)	Description		Illustration								
Torque wrench	<table border="1" data-bbox="459 216 844 510"> <thead> <tr> <th>Size mm (in.)</th> <th>Range kg-cm (lb-ft)</th> </tr> </thead> <tbody> <tr> <td>6-14 (0.236-0.551)</td> <td>40-300 (2.9-21.7) 300-800 (21.7-57.8)</td> </tr> <tr> <td>15 (0.591) 17 (0.669) 19 (0.748) 21 (0.827)</td> <td>300-1,600 (21.7-115.7)</td> </tr> </tbody> </table> <p data-bbox="915 216 1141 296">Use when tightening bolts and nuts with specified torques.</p>		Size mm (in.)	Range kg-cm (lb-ft)	6-14 (0.236-0.551)	40-300 (2.9-21.7) 300-800 (21.7-57.8)	15 (0.591) 17 (0.669) 19 (0.748) 21 (0.827)	300-1,600 (21.7-115.7)			
Size mm (in.)	Range kg-cm (lb-ft)										
6-14 (0.236-0.551)	40-300 (2.9-21.7) 300-800 (21.7-57.8)										
15 (0.591) 17 (0.669) 19 (0.748) 21 (0.827)	300-1,600 (21.7-115.7)										
Plastigage	<p data-bbox="434 621 1108 653">To measure oil clearance between crankpin and main bearing.</p> <table border="1" data-bbox="459 667 1075 800"> <thead> <tr> <th>Type</th> <th>Applicable clearance mm (in.)</th> </tr> </thead> <tbody> <tr> <td>PG-1 (Green)</td> <td>0.025-0.076 (0.001-0.003)</td> </tr> <tr> <td>PR-1 (Red)</td> <td>0.051-0.152 (0.002-0.006)</td> </tr> <tr> <td>PB-1 (Gray)</td> <td>0.102-0.229 (0.004-0.009)</td> </tr> </tbody> </table>		Type	Applicable clearance mm (in.)	PG-1 (Green)	0.025-0.076 (0.001-0.003)	PR-1 (Red)	0.051-0.152 (0.002-0.006)	PB-1 (Gray)	0.102-0.229 (0.004-0.009)	<p data-bbox="1301 667 1422 699">Plastigage</p>  <p data-bbox="1273 785 1455 816">Measuring scale</p>
Type	Applicable clearance mm (in.)										
PG-1 (Green)	0.025-0.076 (0.001-0.003)										
PR-1 (Red)	0.051-0.152 (0.002-0.006)										
PB-1 (Gray)	0.102-0.229 (0.004-0.009)										
Thickness gauge	<p data-bbox="434 852 1166 911">To measure clearances between piston rings and piston grooves or between shaft couplings during installation.</p>										
Battery electrolyte tester (955000-00013)	<p data-bbox="802 1052 1166 1136">To inspect antifreeze solution and electrolyte for specific gravity, and charging condition.</p>										
Compression gauge	<p data-bbox="434 1241 621 1272">L40AE - L100AE</p> <p data-bbox="434 1293 596 1352">Tool set TOL-97190060</p> <p data-bbox="802 1241 1133 1299">To measure compressive pressure in the cylinder.</p>										
Nozzle tester (737600-93502) High pressure pipe (124233-93400)	<p data-bbox="434 1388 769 1419">Pressure gauge: 0-500 kg/cm²</p> <p data-bbox="802 1388 1149 1472">To inspect spray condition and the injection pressure of the fuel injection valve.</p>										
Color check (for flaw detection) Set product (6 bottles) (975500-004560)	<table border="1" data-bbox="434 1671 893 1871"> <tbody> <tr> <td>Penetrant (97550-00451)</td> <td>450 cc (27.5 cu. in.)</td> </tr> <tr> <td>Developer (97550-004520)</td> <td>450 cc (27.5 cu. in.)</td> </tr> <tr> <td>Cleaning agent (97550-004530)</td> <td>450 cc (27.5 cu. in.)</td> </tr> </tbody> </table> <p data-bbox="935 1671 1116 1730">Use in detecting flaws.</p>		Penetrant (97550-00451)	450 cc (27.5 cu. in.)	Developer (97550-004520)	450 cc (27.5 cu. in.)	Cleaning agent (97550-004530)	450 cc (27.5 cu. in.)			
Penetrant (97550-00451)	450 cc (27.5 cu. in.)										
Developer (97550-004520)	450 cc (27.5 cu. in.)										
Cleaning agent (97550-004530)	450 cc (27.5 cu. in.)										

3. Instruments

(Select the appropriate thermometer and tachometer from among the following types.)

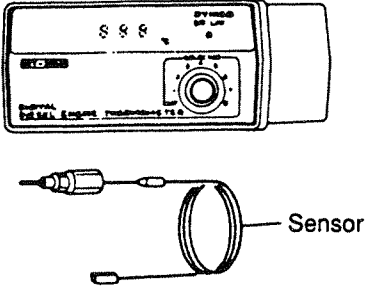
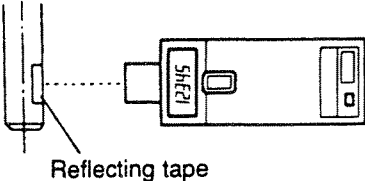
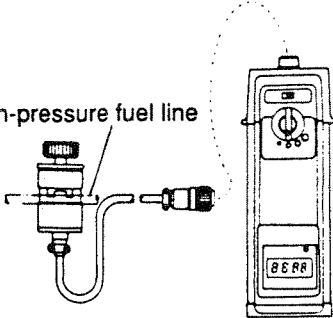
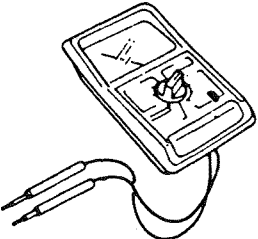
Instrument Name (Yanmar code No.)		Description	Illustration
Thermometer	Digital type Model: BT-800 (955000-08000)	Instantaneously measures temperature in each cylinder using a select switch.	
	Sensor (955000-08640)	CA 64	
Tachometer	Photoelectric type (non-contacting) Model HT-441 (95500H-T4410)	Reflecting tape is applied to the outside of the rotating parts to measure RPMs. Capable of measuring RPM of reduction gears, step-up gears, and pulleys.	
	Reflecting Tape (10 pieces) (955000-01041)		
	High-pressure fuel pipe clamping type Model: GE-450 (955000-01045)	Measures engine RPM's using pulse system.	
Circuit tester		To measure resistance, DC voltage, AC voltage, DC current, and for continuity testing.	

3.2 TIGHTENING TORQUES

Standard bolts and nuts tightening torque:
 M6 70–100 kg-cm (5.1–7.2 lb-ft)
 M8 180–200 kg-cm (13–14.5 lb-ft)

Where specified torque be applied	Model	Thread No. dia. x pitch	Tightening torque kg-cm (lb-ft)	Remarks
Valve rocker arm support	L40AE–L70AE	M8 x 1.25	200–230 (14.5–16.6)	Hexagonal dimension: 12
	L75AE–L100AE	M10 x 1.5	430–470 (31.1–34.0)	Hexagonal dimension: 14
Flywheel end nuts*	L40AE–L70AE	M16 x 1.5	1200–1300 (86.8–94.0)	Hexagonal dimension: 24
	L75AE–L100AE	M18 x 1.5	2200–2300 (159.1–166.3)	
Crankcase cover bolts	L40AE, L48AE	14-M6 x 1.0	100–120 (7.2–8.7)	Hexagonal dimension: 10
	L60AE–L100AE	13-M8 x 1.25	200–230 (14.5–16.7)	Hexagonal dimension: 12
Stiffener bolts on crankcase cover	L40AE–L100AE	M8 x 1.25	200–230 (14.5–16.6)	
Head stud bolts (stud side)*	L40AE, L48AE	4-M8 x 1.25	130–150 (9.4–10.8)	Apply "screw locking agent"
	L60AE, L70AE	4-M9 x 1.25	130–150 (9.4–10.8)	
	L75AE–L100AE	4-M10 x 1.5	130–150 (9.4–10.8)	
Cylinder head nuts*	L40AE, L48AE	4-M8 x 1.25	280–320 (20.3–23.1)	Apply oil to the face of the threaded part. Hexagonal dimension: 12
	L60AE, L70AE	4-M9 x 1.25	420–460 (30.4–33.3)	Hexagonal dimension: 14
	L75AE–L100AE	4-M10 x 1.5	540–580 (39.0–42.0)	Hexagonal dimension: 17
FO nozzle case nut	L40AE–L100AE	1-0.605-40UNS-2B	400–450 (28.9–32.5)	Hexagonal dimension: 15
FO pump delivery holder	L40AE–L100AE	M14 x 1.5	300–350 (21.7–25.3)	Hexagonal dimension: 17
FO pump stud bolts (stud side)*	L40AE–L100AE	3-M6 x 1.0	70–100 (5.1–7.2)	Apply "screw locking agent"
FO pump nuts	L40AE–L100AE	3-M6 x 1.0	100–120 (7.2–8.7)	Hexagonal dimension: 10
FO nozzle bolts (stud side)*	L40AE–L100AE	2-M6 x 1.0	70–100 (5.1–7.2)	Apply "screw locking agent"
FO injection nozzle nuts	L40AE–L100AE	2-M6 x 1.0	100–120 (7.2–8.7)	Hexagonal dimension: 10
Connecting rod bolts & nuts*	L40AE–L70AE	2-M7 x 1.0	180–210 (13–15.2)	Apply oil to the face of the threaded part. Hexagonal dimension: 10
	L75AE –L100AE	2-M8 x 1.0	375–425 (27.1–30.7)	Hexagonal dimension: 13

Notes:

1. For bolts and nuts marked *, apply engine oil to the thread and seat.
2. For bolts and nuts marked *, apply screw locking agent to the thread before threading them.

3.3 MAINTENANCE SCHEDULE

Periodical maintenance is the key to a smooth-running, long-lasting engine. The table below shows when checks should be carried out.

○ Check, Add ● Replace

Item	Operating hours						
	Every day	Every 20 – 50 hrs	Every 100 hrs	Every 200 hrs	Every 500 hrs	Every 1000 hrs	
Check and retighten all bolts and nuts	○				(Head bolt retightening) ○		
Check and add engine oil	○						
Change engine oil		(1st) ●	(2nd and subsequent) ●				
Check and add fuel oil	○						
Clean and replace oil filter						Replace as requierd. ●	
Air cleaner element (Type)	Paper	(In dusty conditions, the element should be replaced more frequently).				● every 500 hours	
	Oil bath				●		
Clean fuel filter					○	(replace-ment) ●	
Check for oil leakage (engine oil, fuel oil)	○						
Check injection nozzle					○		
Check injection pump					○		
Adjust valve clearance of intake and exhaust valves		(1st) ○			○		
Inspection and refacing of intake and exhaust valve seats						○	
Replace piston ring						●	
Check the surfaces of brush and slip ring					○	(for YDG generator)	
Check battery electrolyte level	Check the battery once a month and add electrolyte if necessary.						
Drain fuel from F.O. tank	Monthly						
Check fuel piping					(Replace if necessary) ○		
Clean spark arrester (option)			○				

3.4 DISASSEMBLY PROCEDURES

Basic procedures

- Gather the required tools, jigs and meters.
- Have a notebook, etc. ready for recording service information.
- Fill containers with cleaning solution for cleaning parts.
- Prepare a special place for parts and containers.
- Drain old lubricating oil from engine.
- Arrange disassembled parts.
- Keep all bolts and nuts with their relative parts to make sure they are not reassembled incorrectly.
- Determine exactly what the problem is before disassembly. Never remove unnecessary parts.

1. Fuel tank

- 1) Pull the overflow pipe out toward the tank.
- 2) Release the hose clamp on the pump side of the fuel pipe.
- 3) Remove the fuel tank stay (upper part).
- 4) Remove the fuel tank. (Pull the oil pipe on the pump side up and out.)
 - Release the hose clamp on the pump side.

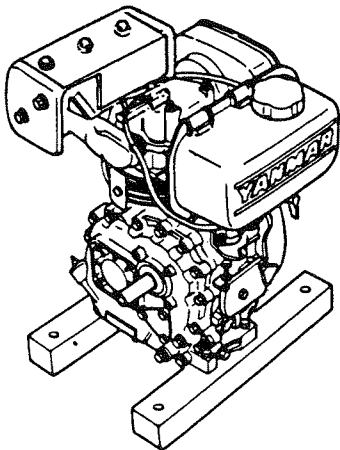

Removing the fuel tank

2. Exhaust silencer

- 1) Remove the flange nuts.
- 2) Remove the stay bolt.

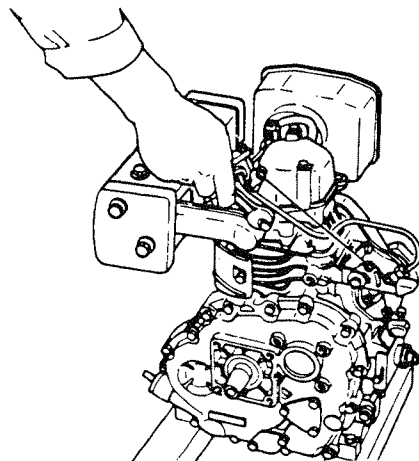

Removing the exhaust silencer

3. Air cleaner

- 1) Remove the air cleaner cover.
- 2) Pull out the filter element.
- 3) Remove the cleaner case.

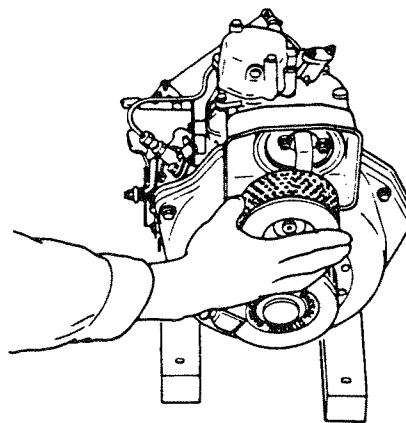

Removing the air cleaner

4. Recoil starter

The recoil starter does not have to be removed every time. Remove only when necessary.

5. Cooling fan case

Remove the cooling fan case.

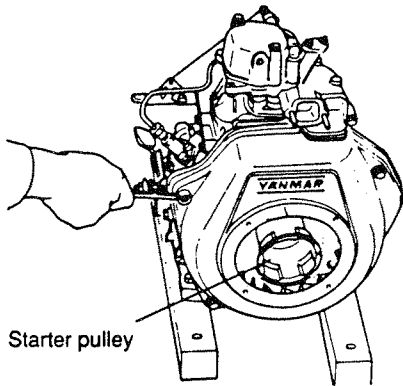

Removing the cooling fan case

6. Starter pulley

Remove the starter pulley.

7. Air intake bend

Remove the air intake bend.

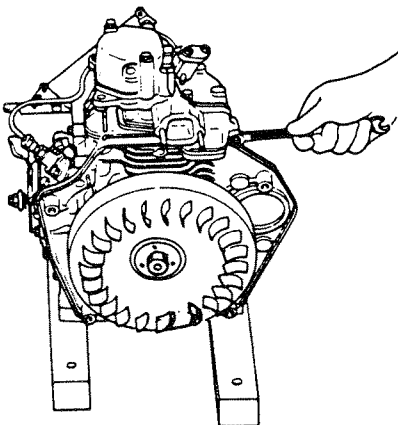

Removing the air intake bend

8. Starting motor

(Only for starter motor specification.)
Remove the starting motor.

9. Valve rocker arm cover

Remove the valve rocker arm cover.

10. Valve rocker arm assembly

Remove the valve rocker arm assembly.

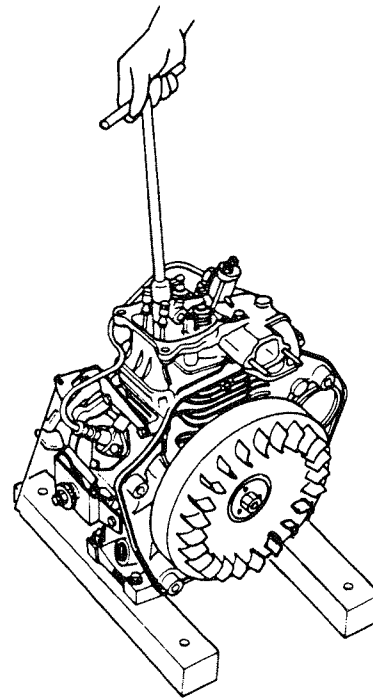

Removing the valve rocker arm assembly

11. Push rods

Pull out the push rods.

12. Fuel injection valve

- 1) Remove the fuel injection pipe.
- 2) Remove the fuel injection valve.
 - If the valve is tight, loosen the nuts using a wrench with the fuel injection pipe set.
 - Be carefully not to damage the nozzle gasket (insulator) and nozzle spacer.

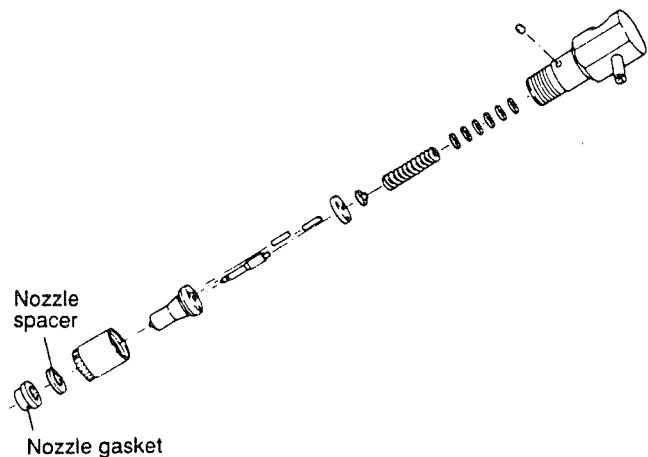

Fuel injection valve disassembled

13. Cylinder head

- 1) Remove the cylinder head
 - Keep the combustion surface faced up.

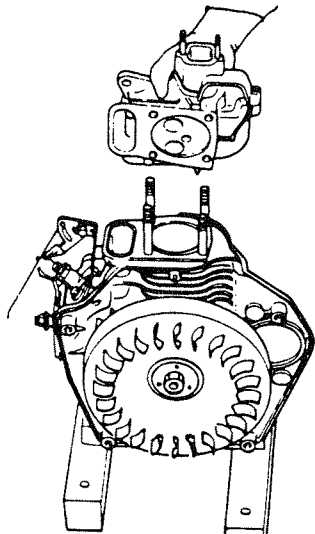

Removing the cylinder head

15. Crankcase cover

- 1) Remove the oil pump cover.
- 2) Remove the oil filter cover.
- 3) Remove the crankcase cover.
 - Step 1) and 2) should only be done when necessary.
 - Be carefully not to damage the oil seal.

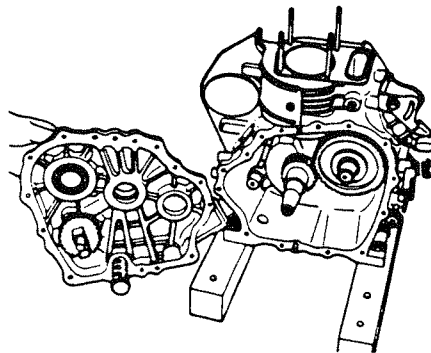

Removing the crankcase cover

14. Fuel injection pump

- 1) Remove the fuel injection pump.
 - Remove the pump together with the base plate.
 - Make sure the hooking of control lever in rack before disassembly.
 - Pull out any remaining flat tappet.

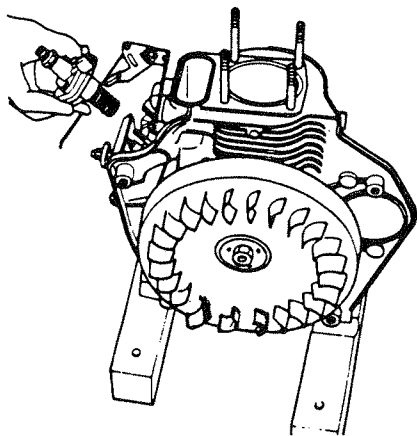

Removing the fuel pump

16. Camshaft

Pull out the camshaft

- Check the timing mark.
- Keep exhaust and intake tappets separate.

They may fall down when pulling out the camshaft and may be confused.

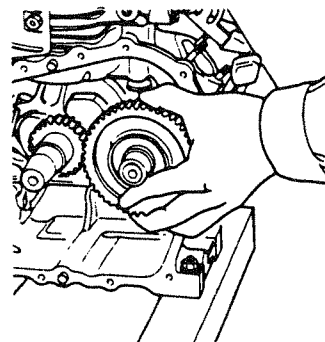

Removing the camshaft

17. Balancer shaft

Pull out the balancer shaft.

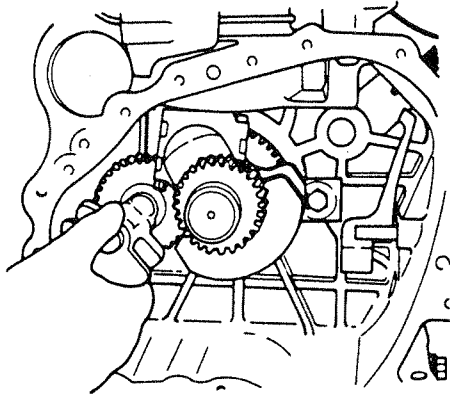

Removing the balancer shaft

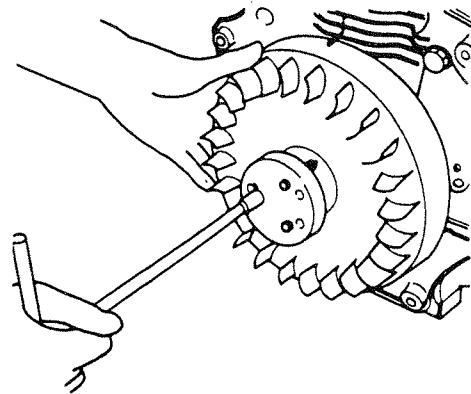

Removing the flywheel

20. Crankshaft

- 1) Remove the flywheel key.
- 2) Remove the bearing holder.
- 3) Pull out the crankshaft.
 - Be carefully not to damage the oil seal.

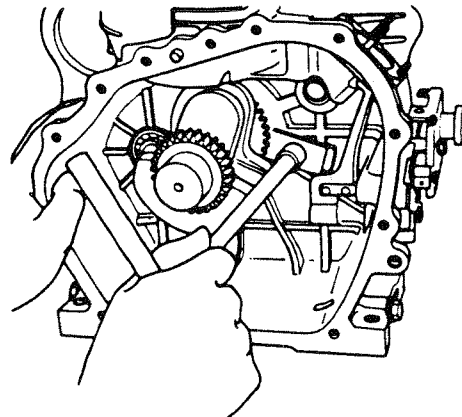

Removing the bearing holder

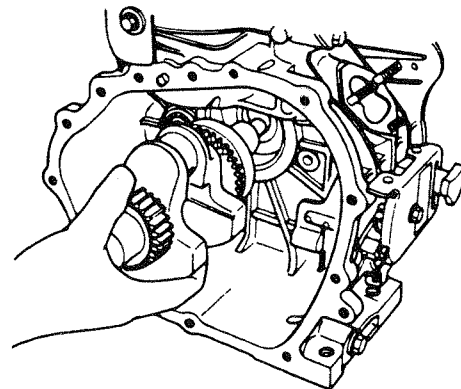

Pulling out the crankshaft

18. Piston and connecting rod assembly

- 1) Remove the connecting rod tightening nuts.
- 2) Remove the big end cap.
- 3) Move the crankshaft to the top of the stroke and pull out the piston.
 - Remove carbon deposited on the upper inside surface of the sleeve (when extracting the piston).
 - Make sure the main bearing is in the proper position.

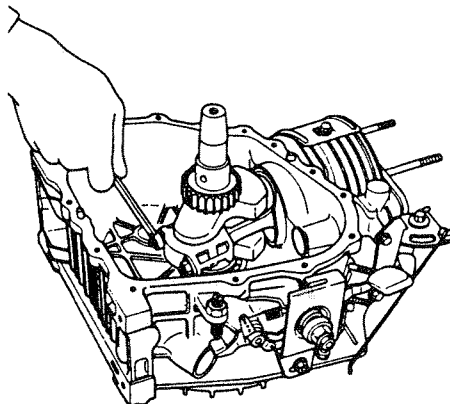

Removing the rod bolts and nuts.

19. Flywheel

- 1) Loosen the lock nut.
- 2) Remove the flywheel.
 - Use flywheel extractor (special tool).
 - Securely thread in the extractor bolts.

21. Governor or speed control device

Remove the governor or speed control device if necessary.

- Damage or scratches on the governor lever shaft can cause hunting and other troubles. Be sure to check the position to retain the regulator spring before removal.

3.5 REASSEMBLY PROCEDURES

Before reassembly

- Thoroughly clean and check all parts.
- Apply new engine oil to the sliding and rotating parts.
- Use new packings and O rings.
- Use liquid packing agents to prevent oil leakage.
- Make sure the clearance between parts (for oil, thrust, etc.) is correct.
- When reassembling, line up matching marks on parts.
- Use the proper bolts, nuts, and washer. Tighten the major bolts and nuts to the specified torque. (Be especially careful with aluminum alloy parts. These are easily damaged.)
- Apply engine oil to threaded parts and flange faces, before tightening the major bolts to the specified torque.

1. Governor or speed control device

Reassemble the governor or speed control device, if it has been removed.

2. Crankshaft

- 1) Insert the crankshaft.
- 2) Attach the key (flywheel) to the crankshaft.
- 3) Install the bearing holder.
 - Make sure that the crankshaft has been inserted as far as it will go.
 - Grease the oil seal lips.
 - Apply oil to the crankshaft journal and pin.

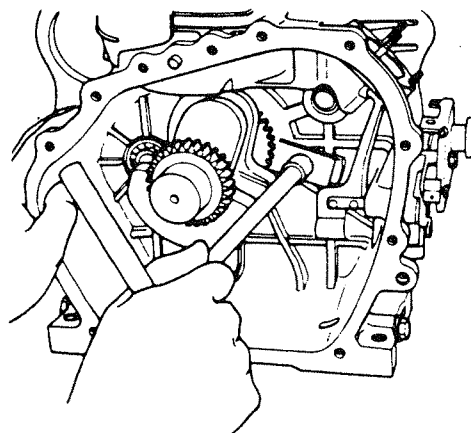

Installing the bearing holder

3. Flywheel

Tighten the flywheel with the retaining tool.

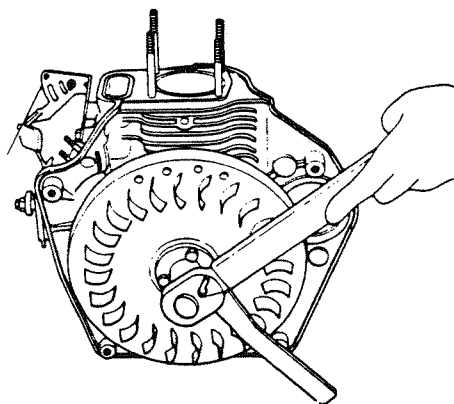

Tightening the flywheel

Flywheel Tightening Torque

kg-cm (lb-ft)

L40AE-L70AE	1,200-1,300(86.8-94.0)
L75AE-L100AE	2,200-2,300(159.1-166.3)

4. Piston and connecting rod

- 1) Insert the piston and connecting rod assembly, move the crankshaft to Top Dead Center. The mark on the piston head should face the crankcase cover side.

2) Install the big end cap.

(Always use a washer for the tightening nuts.)

- Apply oil to the crank pin.
- Install the rings in the proper direction.
- Apply oil to the outer surface of the piston and the inner surface of the sleeve.
- Make sure the main bearing is in the proper position.
- Check Whether the rod bolts retainer is in position.

- Do not confuse exhaust and intake tappets.
- Make sure the gears' matching marks are lined up.

6. Fuel injection pump reassembly
(Temporarily fix in proper position)

Line up the injection volume marks (marking-off) and attach the control lever to the governor lever fork.

Reassembly the fuel injection pump with a nut, for positioning purposes only.

- Make sure the adjusting shims are used correctly.

Connecting Rod Tightening Torque kg-cm (lb-ft)

L40AE-L70AE	180-210 (13.0-15.2)
L75AE-L100AE	375-425 (27.1-30.7)

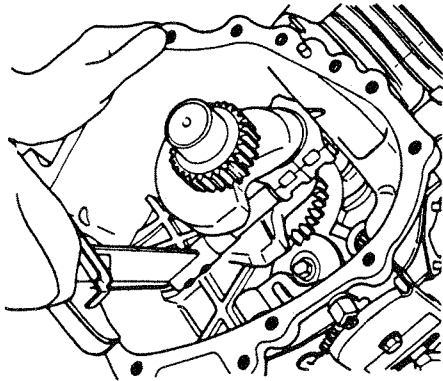

Installing the connecting rod big-end cap

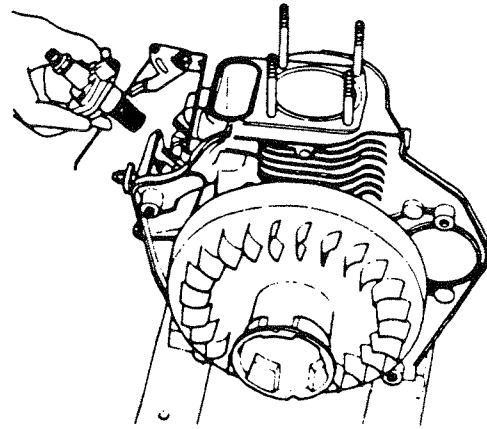

Installing the fuel injection pump

5. Camshaft, Balancer shaft

- 1) Insert the tappets.
- 2) Insert the camshaft.
- 3) Insert the balancer shaft.

7. Crankcase cover

- 1) Place an aluminum packing between the surface of the crankcase and the crankcase cover.

- 2) Reassemble the crankcase cover.

(Tighten bolts in the sequence shown in the below figure. Tighten bolts diagonally)

- To protect the oil seal, attach the jig for inserting the oil seal to the shaft prior to insertion.
- Apply grease to the lips of the oil seal.
- Apply oil to the crank and camshafts.
- Make sure that the oil pump drive gears are properly engaged.

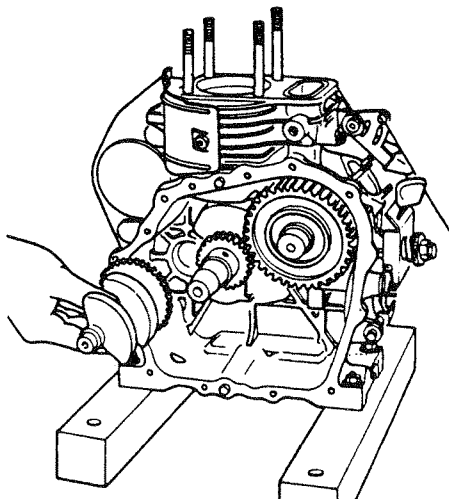

Inserting the balancer shaft

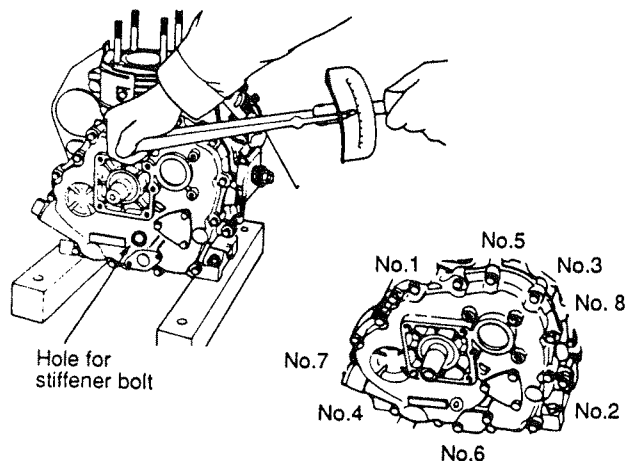

Attaching the crankcase cover and tightening three orders

Case Cover Tightening Torque		kg-cm (lb-ft)
L40AE, L48AE	100-120	(7.2-8.7)
L60AE-L100AE	200-230	(14.5-16.6)

- 3) Stiffener bolts have been added on the crankcase cover to reduce vibration and noise. For an engine with stiffener bolts, tighten them after the bolts on the periphery of the crankcase cover are tightened.

Stiffener Bolts Tightening Torque		kg-cm (lb-ft)
L40AE~L100AE	200-230	(14.5-16.6)

8. Fuel injection pump reassembly (final)

Tighten the fuel injection pump

- See page 58, "Fuel Injection Volume limitation."

Fuel Injection Pump Tightening Torque		kg-cm (lb-ft)
L40AE-L100AE	100-120	(7.2-8.7)

9. Cylinder head

- 1) Place a gasket packing on the cylinder block.
- 2) Attach an O-ring.
- 3) Reassemble the cylinder head.
 - Make sure that the nozzle insulation

packing and spacer are in position.

- Before reassembling the valve spring, place its identification mark (white paint) toward the cylinder head. (L75AE-L100AE)

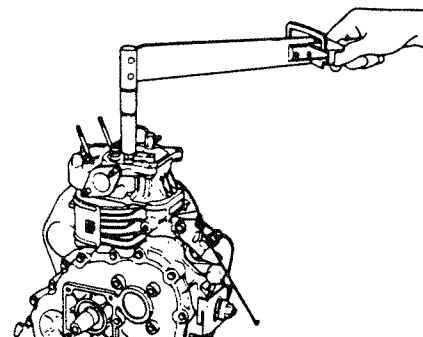

Tightening the bolts of the cylinder head

Tighten separately with two times.

Cylinder Head Tightening Torque		kg-cm (lb-ft)
Model	Final	First
L40AE, L48AE	150 (10.8)	280-320 (20.2-23.1)
L60AE, L70AE	220 (15.9)	420-460 (30.4-33.3)
L75AE-L100AE	300 (21.7)	540-580 (39.0-41.9)

10. Push rods

Insert the push rods.

- Ascertain that the tappets are properly inserted.

11. Valve rocker arm assembly

- 1) Reassemble the valve rocker arm assembly.
- 2) Adjust the valve clearance.

In./Ex.-valve head clearance: 0.15 mm (0.006 in./cold state)

 - Be careful not to lose or damage the knock pin.

Valve Rocker Arm Tightening Torque

kg-cm (lb-ft)

L40AE-L70AE	200-230 (14.5-16.6)
L75AE-L100AE	430-470 (31.1-34.0)

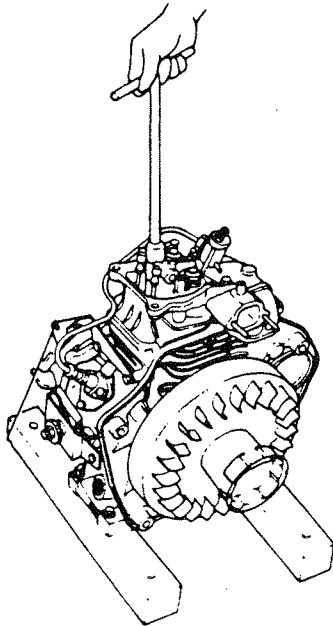

Tightening the valve rocker arm

12. Valve rocker arm cover

Install the valve rocker arm cover.

- Make sure the packing is in position.

13. Fuel injection valve

1) Insert the fuel injection valve.

2) Install the injection pipe.

(Check injection timing. See page 60.)

3) Tighten the injection valve.

- Make sure the fuel injection valve faces to the proper direction.
- Replace the nozzle gasket.

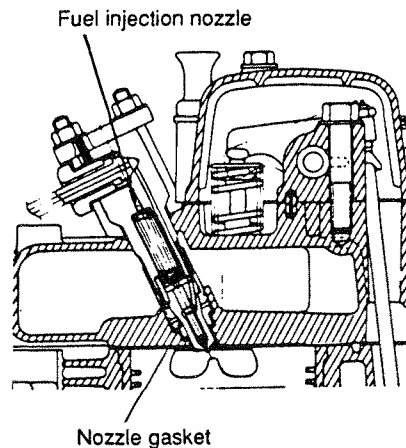

Install the fuel injection valve

Fuel Injection Valve Tightening Torque

kg-cm (lb-ft)

L40AE-L100AE	100-120 (7.2-8.7)
--------------	-------------------

14. Intake bend

Install the intake bend.

- Make sure the intake bend packing is in position.

15. Cooling fan case

1) Install the starter pulley.

2) Install the cooling fan case.

(Re-attach the recoil if it has been removed.)

- Attach the seal rubber to the case.
- Make sure the collar and fancase supporting rubber are in the proper position.

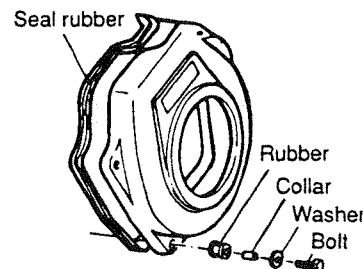

Cooling fan case

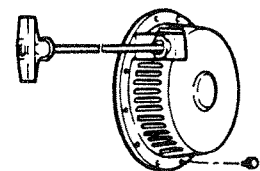

Recoil starter

16. Air cleaner

- 1) Attach the air cleaner case.
- 2) Install the element.
- 3) Install the cover.
 - Make sure the intake bend and packings in position.

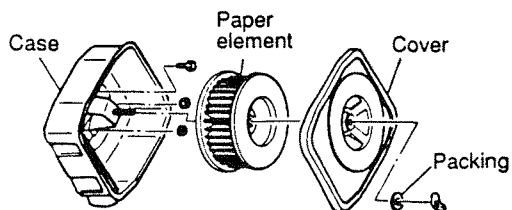

Air cleaner

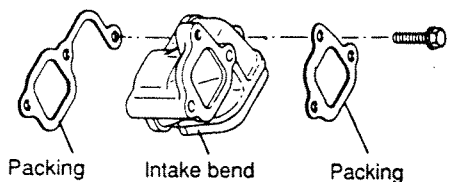

(a) Intake bend

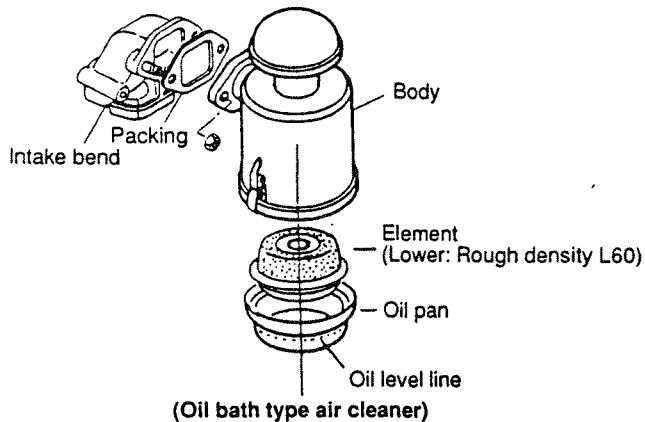

(b) Intake bend

17. Starting motor

(Only for model with starting motor)
Install the starting motor.

18. Exhaust silencer

Install the exhaust silencer.

- The silencer cover does not have to be removed.
- Model L75AE – L100AE have not a rear cover.

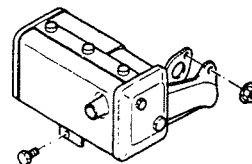
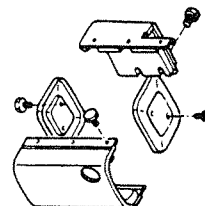

Exhaust silencer

19. Fuel tank

- 1) Connect the fuel pipe to the fuel injection pump.
- 2) Attach the fuel tank using the upper stay.
- 3) Insert the fuel return pipe to the fuel tank.
 - Make sure the fuel tank supporting rubber (vibration absorbing rubber) stays in place.

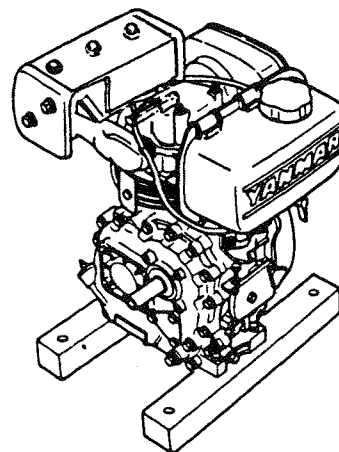

Installing the fuel tank

3.6 RECOIL STARTER

The recoil starter will not be trouble in normal usage. However, should it break, or when it must be lubricated, disassemble and reassemble it according to the following procedures:

(Tools used: box wrench, pliers, screw driver)

1. Disassembling procedures

- 1) Remove the recoil starter from the engine. (Use box wrench.)
- 2) Pull out the grip and draw out the starter rope for approx. 30 cm. When the reel's notch came at the outlet of the starter rope, fasten the reel's turning by your thumb and draw up the starter rope inside the recoil starter using a screwdriver as shown in Fig. (a).

Then, wind back the rope until the reel stops to turn by turning the reel with your thumb at the reel's notch.

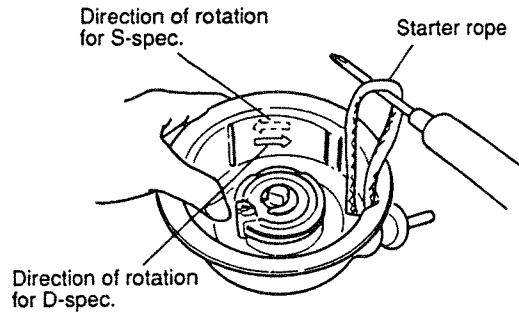

(a)

- 3) Remove the parts as shown in Fig. (b)~(d). To remove the E-ring, fasten the shaft by the pliers, and twist the E-ring left and right.
 - Model L60AE/L70AE have an additional slide plate. Model L40AE/L48AE and L75AE to L100AE have only the friction plate (Model L60AE to 100AE differ in the recoil starter complete and tightening nut (E-ring) both of which are used for the threaded recoil shaft.)

L40AE · L48AE

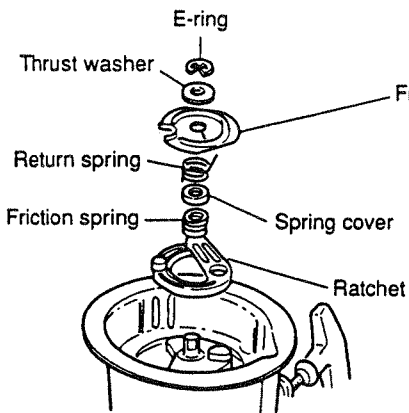

(b)

L60AE · L70AE

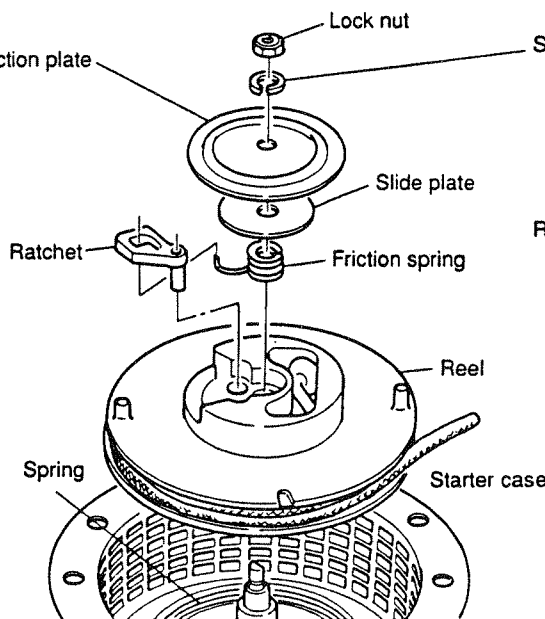

(c)

L75AE-L100AE

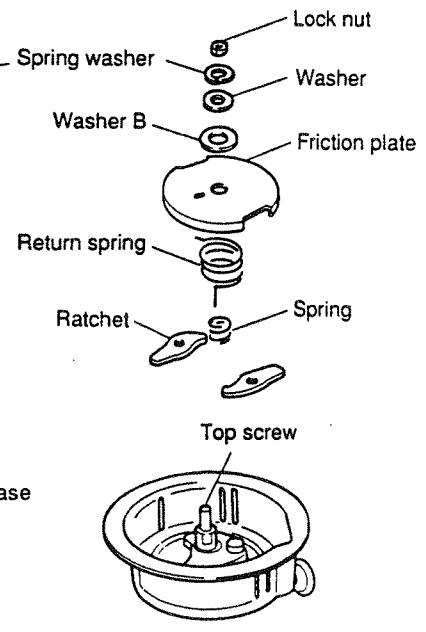

(d)

- 4) Remove the reel from the starter case as shown in Fig. (e). Take out the reel slowly while turning it lightly to the left and right to remove the spring. Take care not to take out the reel quickly. Otherwise, the spring may jump out its housing. (If the spring runs out of position, put it in the starter case as illustrated in Fig. (f))

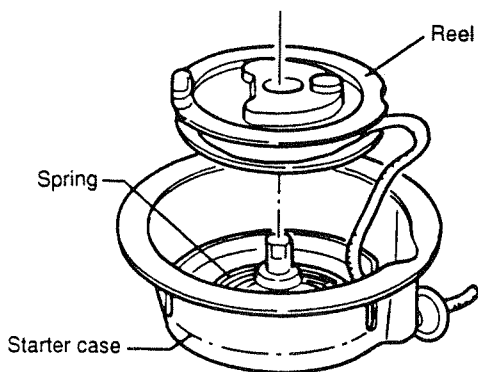

(e)

2. Assembling procedures

- 1) Check that the spring is set correctly in the starter case housing. Adjust the shape of the inner end of the spring to locate it at about 4 mm from the starter shaft for making the reel's hook engages with the spring correctly.

(The inner end of the spring can be simply reshaped by pliers for a length of about 10 mm.)

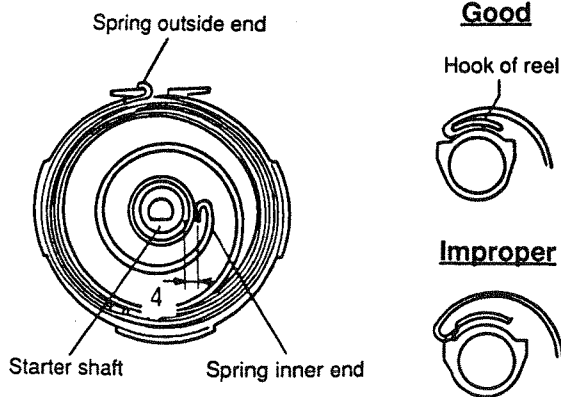

(f)

- 2) Wind the starter rope around the reel to the arrow mark direction as shown in Fig. (g). Take out the rope from reel's notch at the 2.5 turns, fit the reel's hook to the inner end of the spring, and reassemble the reel correctly into the starter case. (The reel's hook can't be seen on reassembly, so take care to reassemble correctly as the improper example shown in Fig. (f).)

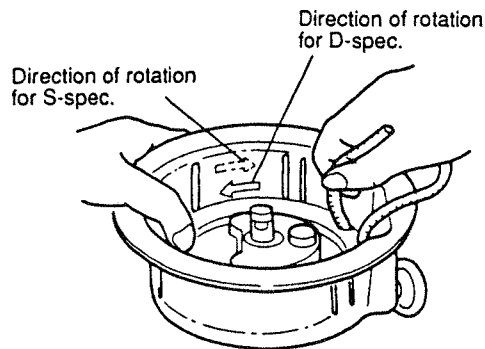

(g)

- 3) Hold the starter rope as shown in Fig. (h). Wind it 4 turns in the arrow direction while securely holding the reel so that the rope may not be reversed. Lead the starter rope from the inside to outside. Slowly turn the reel in reverse.

- 4) Assemble the removed parts in the reverse order of the disassembly in Fig. (g).

When setting the friction plate, first set the return spring slightly lift and then insert it into the mating hole of the friction plate, as shown in Fig. (h) and (i).

Turn the friction plate a little to the arrow direction. When the ratchet boss aligns with the guide, assemble the thrust washer and the E-ring (nut for L60AE and upper models) while securely pressing down the friction plate to the reel. (Place the E-ring in the groove of the starter shaft once manually, and then fasten it with the pliers.)

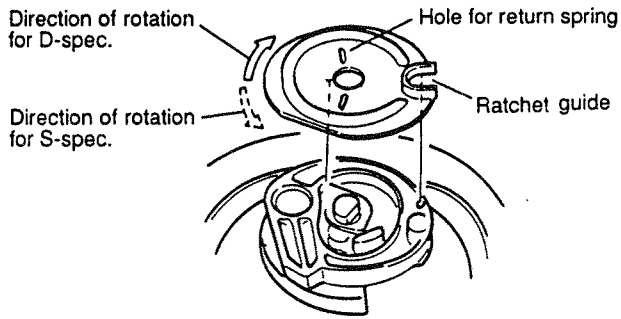

(h) L40AE/L48AE

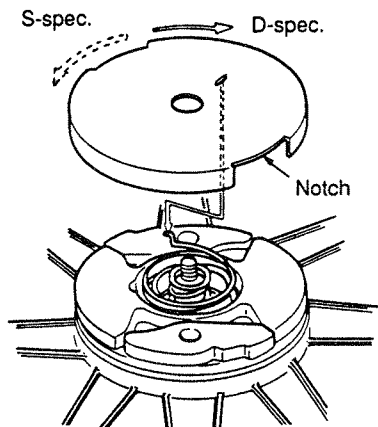

(i) L75AE~L100AE

This completes the disassembly and reassembly. For cautions sake, be sure to check that all the parts are reassembled correctly according to the following procedures.

3. Checks after reassembly

- 1) Pull out the starter rope a little by pulling the grip 2 or 3 times.
 - ① When the grip is too heavy to pull, check whether the parts are reassembled correctly.
 - ② When the ratchet does not move, check whether the friction spring is reassembled.
- 2) Pull out the starter rope for the full stroke with drawing the grip.
 - ① When the starter rope is left inside the reel or the starter rope will not return at

all, an undue force is applied to the spring. In this case, rewind the starter rope one or two turns according to the procedures under Fig. (a).

- ② When the return of the starter rope is weak, or the grip hangs down in the midway, lubricate the friction parts with several drips of engine oil. When the failure can't be corrected still, rewind the starter rope one or two turns. (Check whether an undue force is applied to the spring, according to the procedure in ① above.)
- ③ When the spring is detached from the reel's hook and the starter rope can't be wound inside the reel, follow the reassembly procedure again.

4. Checking and Servicing

4.1 CYLINDER HEAD

1. Combustion surfaces

Remove the fuel injection valve, intake valve, and exhaust valve. Clean the valve combustion surface and check for crack and other damage. Use the color penetrant to check for minute cracks.

2. Intake and exhaust valve seats

The valve seats are cold-fitted in the cylinder head to improve its wear resistance. Clean off carbon deposited on the valve seats since carbon build-up, excessive wear and corrosion can cause compression leaks.

Valve seats are chilled by the liquid nitrogen and inserting to the cylinder head.

(temperature difference:
190°–200°C (374–392°F)

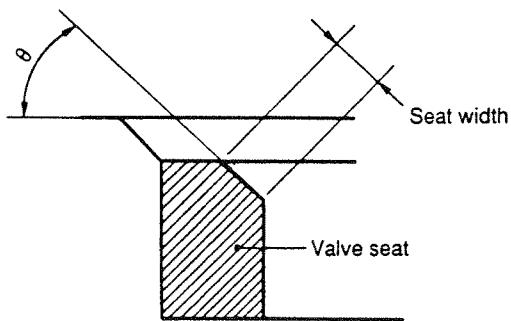

mm (in.)

Model	L40AE – L100AE	
Item	Standard	Service limit
Seat angle (θ)	60°–90°	—
Seat width	1.5–3.0 mm (0.059–0.118 in.)	—

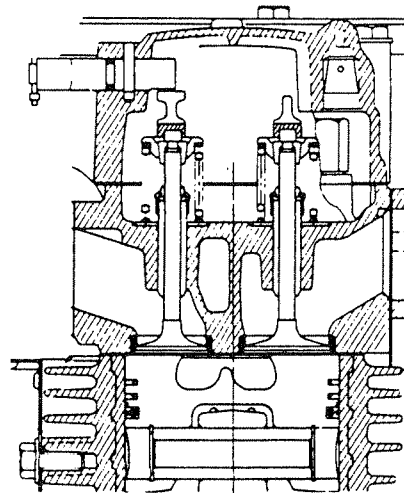

Intake/exhaust valve assembly

3. Intake/exhaust valves, and valve guides

- 1) Check the valve stem for wear and distortion and replace if necessary. Do not confuse the intake and exhaust valve stems.

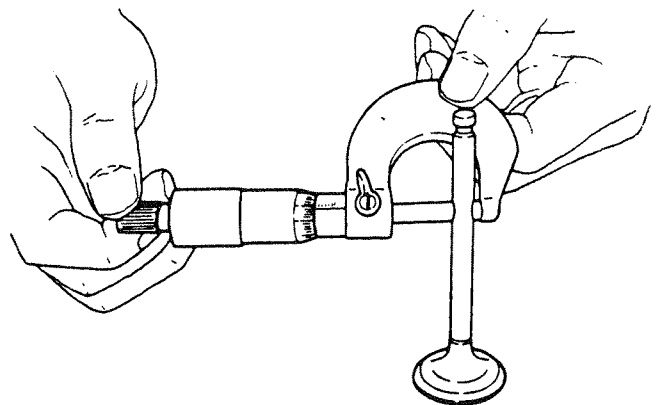

- 2) Check the valve sinkage. Replace worn-out valves (See service limits below).

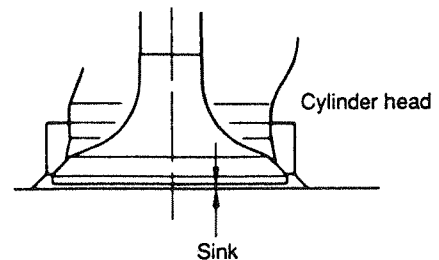

mm (in.)

Item	L40AE~L100AE	
	Standard	Service limit
Valve sinkage	0.3-0.7 (0.012-0.028)	1.1 (0.043)

In./Ex. Valve guide and valve stem

mm (in.)

Model	Item	Valve guide I.D.		Valve stem O.D.	
		Intake	Exhaust	Intake	Exhaust
L40AE L48AE	Standard	5.5-5.515 (0.2165-0.2171)		5.465-5.475 (0.2152-0.2156)	5.450-5.460 (0.2146-0.2150)
	Service limit	5.58 (0.2197)		5.40 (0.2126)	
L60AE L70AE	Standard	6.0-6.015 (0.2362-0.2368)		5.960-5.975 (0.2346-0.2352)	5.945-5.960 (0.2341-0.2346)
	Service limit	6.08 (0.2394)		5.90 (0.2323)	
L75AE L100AE	Standard	7.0-7.015 (0.2756-0.2762)		6.960-6.975 (0.2740-0.2745)	6.945-6.960 (0.2734-0.2740)
	Service limit	7.08 (0.2787)		6.90 (0.2717)	

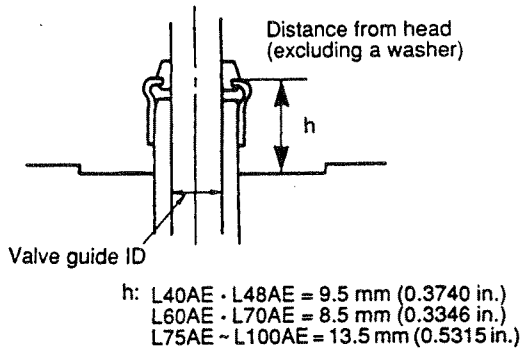

CAUTION:

1. The intake/exhaust valve guides are provided with a valve stem seal. Stem seals cannot be reused, and must be replaced with new ones.
2. When inserting the intake and exhaust valve apply lub. oil to valve stem.

(Valve stem seal)

4. Valve spring

- 1) Check the valve spring for flaw and corrosion.
- 2) Measure the free length.
- 3) Measure the spring inclination (how far the spring inclines to the left or right).
- 4) Measure the spring tension (on a spring tension tester).

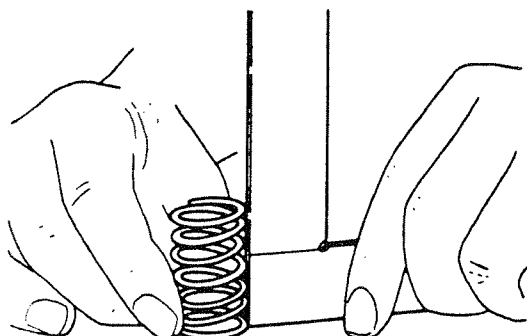

Variable pitch spring
(applied to L75AE~L100AE)

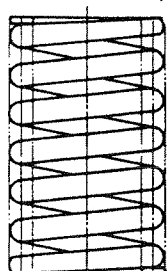

ID mark (white painted)

- Precaution for assembling the valve spring. (Applicable to L75AE to L100AE)
Place the identification mark (white painted) of the valve spring toward the cylinder head.

5. Measuring the top clearance

- 1) Remove the cylinder head. Place high-quality fuses (ø1.2 × about 10 mm (0.39 inch)) at three points on the upper part of the piston.
- 2) Reassemble the gasket packing and the head. Tighten them to the specified torque in the specified tightening order.
- 3) Press down the fuses with the piston by turning the crankshaft in its normal direction.
- 4) Remove the cylinder head and take out collapsed fuses. Measure the thickness of three crushed fuses. Instead of removing the cylinder head, thread a string tied to the fuse through the nozzle hole, pull it out to bring the fuse on the cylinder head as shown in the figure below, and apply step (3) described above.
- 5) The top clearance is the average of the three measured thicknesses. Obtain the mean value of the three thicknesses.

Valve spring

mm (in.)

Item	L40AE, L48AE		L60AE, L70AE		L75AE~L100AE	
	Standard	Service limit	Standard	Service limit	Standard	Service limit
Free length(A)	28 (1.102)	26.5 (1.043)	3.3 (1.299)	31.5 (1.240)	40 (1.575)	39.5 (1.555)
Inclination(B)	< 0.75 (0.030)	—	< 0.6 (0.024)	—	< 1.0 (0.039)	—
Spring tension per 1 mm kg (lb)	1.14~1.4 (2.51~3.09)	—	1.27~1.55 (2.80~3.42)	—	1.80~2.51 (3.97~5.51)	—

		mm (in.)
Model	L40AE-L100AE	
Item	Standard	
Top clearance	0.5-0.7 (0.0197-0.0276)	

6. Intake and exhaust valve rocker arms and push rods

1) Valve rocker arm shafts

Measure the O.D. of the shaft and the I.D. of the valve rocker arm. Replace the valve rocker arm shaft or valve rocker arms if it exceeds the service limits.

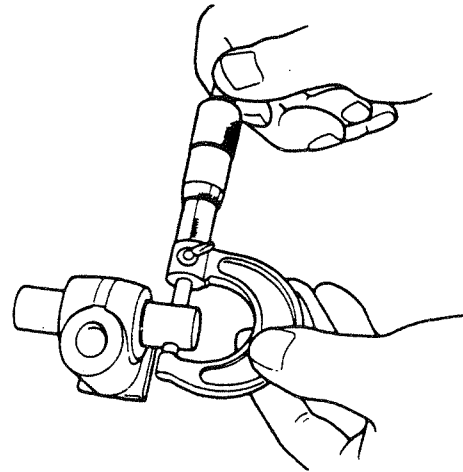
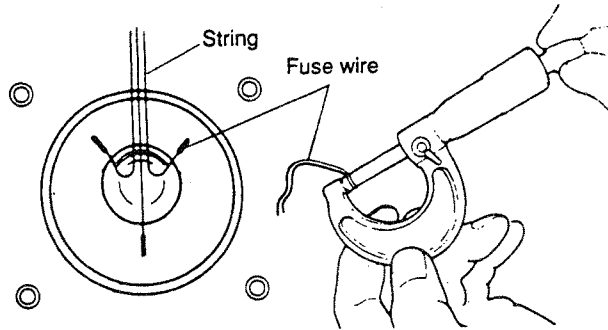
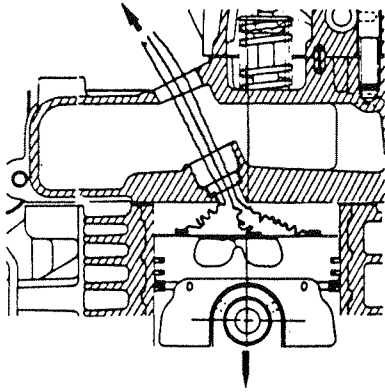

IN./EX. Valve rocker arm

mm (in.)

Item	L40AE-L70AE		L75AE-L100AE	
	Standard	Service limit	Standard	Service limit
O.D. of IN. & EX. valve rocker arm shaft	11.989-12.000 (0.4720-0.4724)	11.90 (0.4685)	14.989-15.000 (0.5901-0.5906)	14.90 (0.5866)
I.D. of IN. & EX. valve rocker arms	12.016-12.034 (0.4731-0.4738)	12.10 (0.4764)	15.016-15.034 (0.5912-0.5919)	15.10 (0.5945)

2) Push rods

Check the push rod length and distortion.

Push rod

mm (in.)

Model	Push rod length		Push rod distortion	
	Standard	Service limit	Standard	Service limit
L40AE, L48AE	129.8 - 130.2 (5.110 - 5.126)	—	< 0.05 (0.0020)	0.3 (0.0118)
L60AE, L70AE	162.3-162.7 (6.390-6.406)			
L75AE - L100AE	196.8-197.2 (7.748-7.764)			

7. Adjusting the valve clearance

- 1) The valve clearance should be adjusted while the engine is in the cold state.

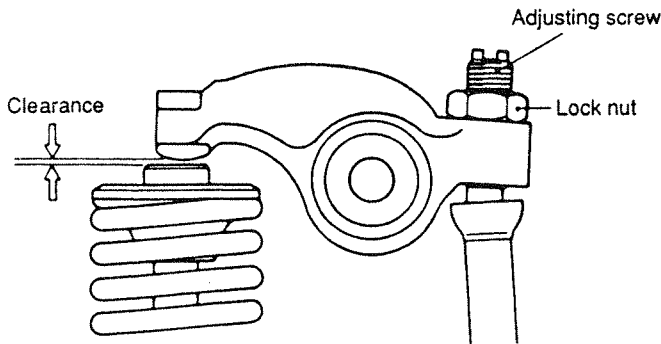

Valve clearance		mm (in.)	
Model		L40AE-L100AE	
Item		Standard	
Intake		0.15	
Exhaust		(0-0.059)	

- 2) The table below shows the proper valve timing.

Valve timing

Model		L40AE-L70AE	L75AE-L100AE
Item		Standard	
Intake	open	bTDC 25°	bTDC 20°
	closed	aBDC 59°	aBDC 53°
Exhaust	open	bBDC 59°	bBDC 53°
	closed	aTDC 25°	aTDC 20°

8. Identification of cylinder head

Model L70AE is provided with the cylinder head peculiar to the model, and has an identification stamp accordingly.

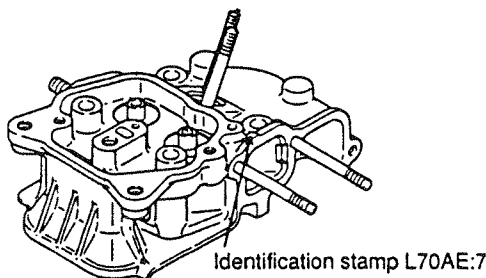

4.2 PISTON AND PISTON PIN

1. Piston

CAUTION:

The intake/exhaust valve recesses are added to the top surface of the piston (applicable to L40AE-L70AE) as a result of a change in the camshaft. When replacing piston, take special care of interchangeability of parts

- 1) Checking the piston top and combustion surface

Remove carbon build-up on the piston top and combustion surface. Be careful not to scratch the surface. Check the combustion surface for damage.

- 2) Checking and measuring piston O.D.

- (1) Replace the piston if the outer surface and ring groove are damaged excessively.

- (2) Measure piston O.D. across the piston pin approx. 12 mm (0.47 in.) from the bottom end of the piston.

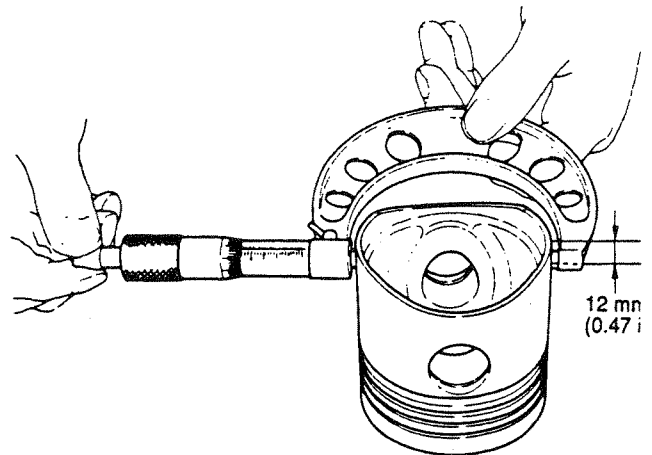

- 3) Piston and piston pin

To remove piston pin, heat piston to 70-80°C (158-176°F), before extruding it.

To reassemble it, repeat the same step.

2 Piston pin

Measure the O.D. of the piston pin. Replace if it worn exceeds the service limit or excessively stepped and worn.

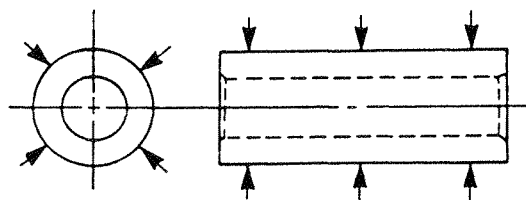

(Measuring point of piston pin)

Piston pin O.D.

mm (in.)

Item \ Model	L40AE, L48AE	L60AE, L70AE	L75AE -L100AE
Standard	18.992-19.000 (0.7477-0.7480)	20.991-21.000 (0.8264-0.8268)	22.991-23.000 (0.9052-0.9055)
Service Limit	18.92 (0.7449)	20.91 (0.8232)	22.91 (0.9020)

3. Checking piston pin hole

- 1) Replace the piston if the pin hole is discolored or damaged.
- 2) Measure the I.D. of the piston pin hole. If it exceeds the service limits, replace the piston.
- 3) Piston replacement procedure
Heat the piston to 70~80°C (158~176°F), align the small end hole with the piston pin hole, then, insert the piston pin into the hole.

Recommended way of heating

Heat the piston in oil. Avoid heating it directly.

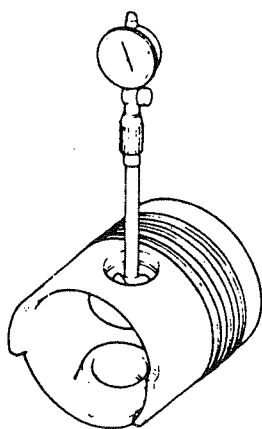

(Checking piston pin hole)

Piston O.D.

mm (in.)

Model	Standard	Service limit
L40AE	67.965 (2.6758)	67.68 (2.6646)
L48AE	69.965 (2.7545)	69.70 (2.7441)
L60AE	74.965 (2.9514)	74.70 (2.9410)
L70AE	77.965 (3.0694)	77.70 (3.0591)
L75AE	79.965 (3.1482)	79.70 (3.1378)
L90AE	83.965 (3.3057)	83.70 (3.2953)
L100AE	85.965 (3.3844)	85.70 (3.3740)

Clearance between Piston and Sleeve

mm (in.)

Model	Standard	Service limit
L40AE-L90AE	0.04-0.06 (0.00157-0.00236)	—
L100AE	0.05-0.07 (0.00197-0.00276)	—

Piston pin hole I.D.

mm (in.)

Model	Standard	Service limit
L40AE-L48AE	18.985-18.996 (0.7474-0.7479)	19.07 (0.7508)
L60AE-L70AE	20.983-20.996 (0.8261-0.8266)	21.07 (0.8295)
L75AE-L100AE	22.983-22.996 (0.9048-0.9054)	23.07 (0.9083)

Clearance between piston pin hole and pin
mm (in.)

Model	Standard	Service limit
L40AE	0.004–0.015 (0.0002–0.0006)	—
L48AE– L100AE	0.005–0.017 (0.0002–0.0007)	—

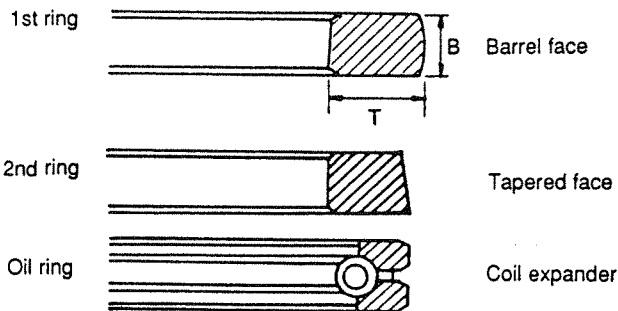

4. Piston rings

1) Measuring piston rings

Measure the thickness and width of the piston ring. Insert the piston ring into the piston ring groove and measure the clearance.

Replace the piston ring if it exceeds the service limit.

(Ring configuration)

Piston ring

Model		1st ring		2nd ring		Oil ring	
		T	B	T	B	T	B
L40AE	Standard	2.7–2.9 (0.1063–0.1141)	1.470–1.485 (0.0579–0.0585)	2.75–2.95 (0.1083–0.1161)	1.470–1.490 (0.0579–0.0587)	2.6–2.8 (0.1024–0.1102)	3.470–3.490 (0.1366–0.1374)
	Service limit	2.52 (0.0992)	1.36 (0.0535)	2.75 (0.1083)	1.36 (0.0535)	2.49 (0.0980)	3.36 (0.1323)
L48AE	Standard	3.0–3.2 (0.1181–0.1260)	1.470–1.485 (0.0579–0.0585)	3.0–3.2 (0.1181–0.1260)	1.470–1.490 (0.0579–0.0587)	2.0–2.4 (0.0787–0.0945)	3.470–3.490 (0.1366–0.1374)
	Service limit	2.77 (0.1091)	1.36 (0.0535)	2.77 (0.1091)	1.36 (0.0535)	1.99 (0.0783)	3.36 (0.1323)
L60AE L70AE	Standard	3.2–3.4 (0.1260–0.1339)	1.470–1.485 (0.0579–0.0585)	3.2–3.4 (0.1260–0.1339)	1.470–1.490 (0.0579–0.0587)	2.1–2.5 (0.0827–0.0984)	3.470–3.490 (0.1366–0.1374)
	Service limit	2.97 (0.1169)	1.36 (0.0535)	2.97 (0.1169)	1.36 (0.0535)	2.07 (0.0815)	3.36 (0.1323)
L75AE	Standard	3.3–3.5 (0.1299–0.1378)	1.470–1.485 (0.0579–0.0585)	3.3–3.5 (0.1300–0.1378)	1.970–1.990 (0.0776–0.0783)	2.4–2.8 (0.0945–0.1102)	3.970–3.990 (0.1563–0.1571)
	Service limit	3.07 (0.1209)	1.36 (0.0535)	3.07 (0.1209)	1.86 (0.0732)	2.37 (0.0933)	3.86 (0.1520)
L90AE	Standard	3.4–3.6 (0.1339–0.1417)	1.470–1.485 (0.0579–0.0585)	3.4–3.6 (0.1339–0.1417)	1.970–1.990 (0.0776–0.0783)	2.5–2.9 (0.0984–0.1141)	3.970–3.990 (0.1563–0.1571)
	Service limit	3.17 (0.1248)	1.36 (0.0535)	3.17 (0.1248)	1.86 (0.0732)	2.47 (0.0972)	3.86 (0.1520)
L100AE	Standard	3.6–3.8 (0.1417–0.1496)	1.470–1.485 (0.0579–0.0585)	3.6–3.8 (0.1417–0.1496)	1.970–1.990 (0.0776–0.0783)	2.5–2.9 (0.0984–0.1141)	3.970–3.990 (0.1563–0.1571)
	Service limit	3.37 (0.1327)	1.36 (0.0535)	3.37 (0.1327)	1.86 (0.0732)	2.47 (0.0972)	3.86 (0.1520)

Piston ring side clearance mm (in.)

Item		Model	L40AE-L70AE	L75AE-L100AE
1st ring	Ring width		1.5 (0.0591)	2.0 (0.0787)
	Ring groove			
	Side clearance	Standard		0.065-0.095 (0.0026-0.0037)
Limit			0.15 (0.0059)	
2nd ring	Ring width		1.5 (0.0591)	2.0 (0.0787)
	Ring groove			
	Side clearance	Standard		0.03-0.065 (0.0012-0.0026)
Limit			0.15 (0.0059)	
Oil ring	Ring width		3.5 (0.1378)	4.0 (0.1575)
	Ring groove			
	Side clearance	Standard		0.02-0.055 (0.0008-0.0022)
Limit			0.15 (0.0059)	

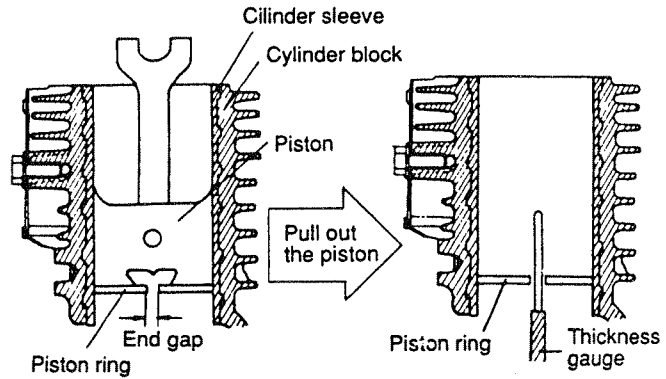

(Push in the piston ring using the piston head)

(Measure a piston ring end gap by inserting a thickness gauge into it.)

(Measuring of ring end gap)

Measuring of ring end gap mm (in.)

Item		Model	L40AE-L100AE	
			Standard	Service limit
Piston ring end gap	1st ring		0.20-0.35 (0.0078-0.0138)	1.0 (0.0394)
	2nd ring		0.30-0.45 (0.0118-0.0177)	
	Oil ring		0.15-0.35 (0.0059-0.0138)	

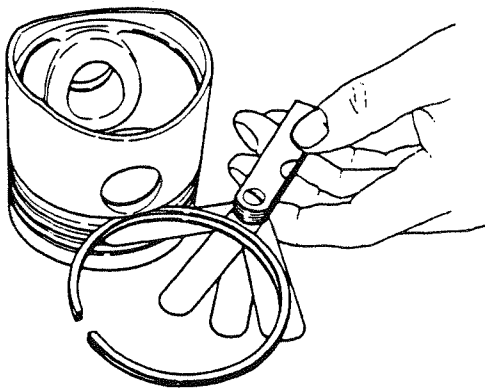

Measuring the clearance between the piston ring and groove (Side clearance)

2) Measuring piston ring end gap

Measure the ring end gap by using a new cylinder, which is free from wear. If measuring the clearance in an engine which is in use, measure at the lower part of the cylinder as this will be most free from wear. Push the ring into the cylinder with the piston top.

3) Cautions when replacing piston rings

- (1) Use the special-purpose tool to attach or remove the piston ring. Never stretch the piston ring.
- (2) Carefully clean the ring groove. The end gap of the top ring should face the intake side.
- (3) When inserting the ring, the maker should face up.

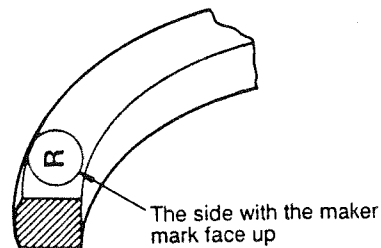

- (4) Make sure the ring moves smoothly.
- (5) When inserting the coil expander into the oil ring, make sure the coil expander joint is opposite to the ring end gap.
- (6) Make sure each piston ring gap is 120° apart.

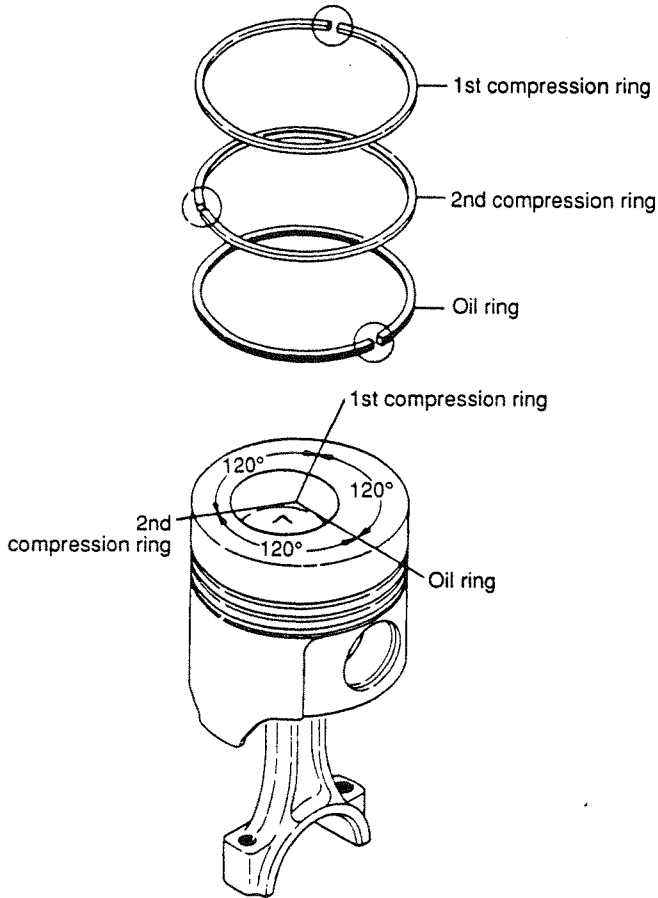

4.3 CONNECTING ROD

1. Checking the connecting rod

- 1) Parallelism or distortion of the large and small end holes.

Pass the measuring jigs through the large and small end holes of the connecting rod to measure parallelism or distortion.

Replace the rod if it is bent beyond the allowable limit.

		mm (in.)
Item	L40AE-L100AE	
Parallelity or distortion	0.05 (0.0020)	

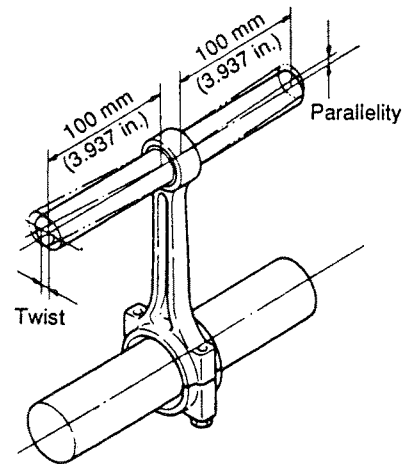

- 2) Side gap of connecting rod

Re-attach the connecting rod to the crank pin to make sure the gap in the crankshaft direction is proper. Make sure the thrust surfaces on both ends are not damaged.

		mm (in.)
Item	Model L40AE-L100AE	
Side gap	0.2-0.4 (0.0079-0.0157)	

Small & large end hole of Connecting rod

Item		Model		L40AE, L48AE		L60AE, L70AE		L75AE-L100AE	
		Standard	Service limit	Standard	Service limit	Standard	Service limit		
Small end hole (Piston pin)	ID	19.012-19.024 (0.7485-0.7490)	19.10 (0.7520)	21.014-21.028 (0.8273-0.8279)	21.10 (0.8307)	23.025-23.038 (0.9065-0.9070)	23.10 (0.9094)		
	Oil clearance	0.015-0.030 (0.0006-0.0012)	—	0.017-0.034 (0.0007-0.0013)	—	0.028-0.044 (0.0011-0.0017)	—		
Large end hole (Crank pin)	ID (Y-Y direction)	30.007-30.015 (1.1814-1.1817)	30.09 (1.1846)	36.007-36.015 (1.4176-1.4179)	36.09 (1.4209)	40.000-40.042 (1.5748-1.5765)	40.08 (1.5780)		
	Oil clearance	0.025-0.050 (0.0010-0.0020)	—	0.025-0.050 (0.0010-0.0020)	—	0.033-0.062 (0.0013-0.0024)	—		

Material: L40AE-L70AE : Aluminum alloy, stamp forging
 L75AE-L100AE : Carbon steel alloy, stamp forging

2. Checking the crank pin metals

- 1) Check the contact surface of the crank pin metals for separation, melting seizure, etc. Replace it if it is separated or damaged.

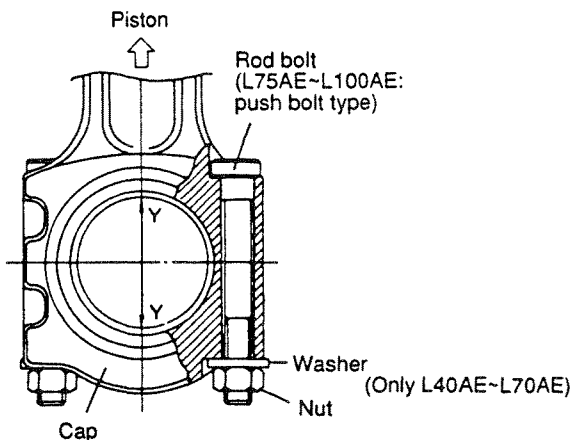

(Check of crank pin metal)

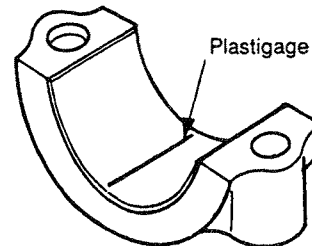

- (3) Attach the connecting rod to the crank pin and tighten the connecting rod to the specified torque.
- (4) Remove the rod and measure the crushed plastigage with the measuring scale.

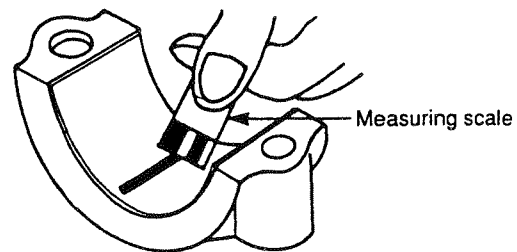

(Measuring the crank pin metal clearance)

- 2) Measuring clearance between crank pin and crank pin bearing metals.

(Use plastigage.)

- (1) Remove the bearing cap and wipe the oil from the bearing metals and crank pin.
- (2) Insert a plastigage into the cap on the large end in the crankshaft direction.

Tightening torque

kg-cm (lb-ft)

Item \ Model	L40AE-L70AE	L75AE-L100AE
Connecting rod	180-210 (13.0-15.2)	375-425 (27.1-30.7)

Clearance between crank pin and metal

mm (in.)

Item \ Model	L40AE-L70AE	L75AE-L100AE
Standard	0.025-0.050 (0.0010-0.0020)	0.033-0.062 (0.0013-0.0024)
Service limit	0.12 (0.0047)	

Measuring clearances between crank pins and crank pin bearing metals.

Line up it using the undersized crank pin metal if it exceeds the service limit.

(Undersized crank pin metal, Part No.)

Item \ Model	L40AE, L48AE	L60AE, L70AE	L75AE-L100AE
Standard	714250-23600	714350-23600	714650-23600
Under-size 0.25 mm (0.0098 in.)	714250-23610	714350-23610	714650-23610
Under-size 0.50 mm (0.0197 in.)	714250-23620	714350-23620	714650-23620

3. Connecting the piston and connecting rod

Line up the position of the piston top mark and the matching marks on the connecting rod as shown in the illustration. When inserting the piston into the cylinder, position the piston top mark so that it faces the crankcase cover side (gear box).

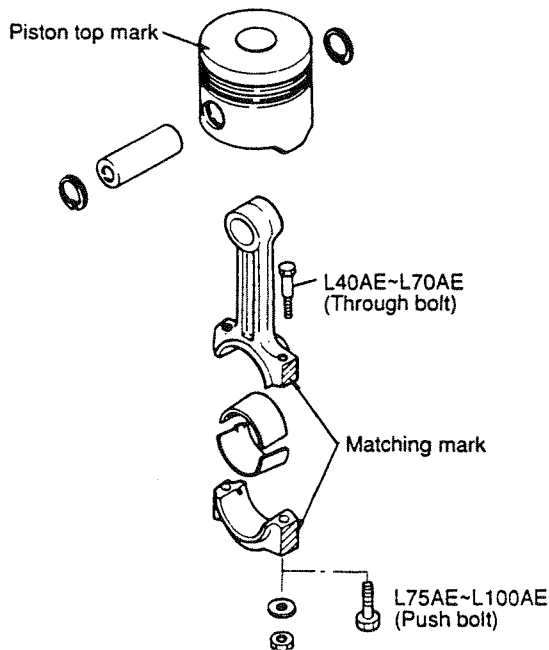

(Line up the piston and connecting rod)

Piston top mark

Piston top marks are stamped, as shown below, depending on specifications [S-spec. or D-spec.] and piston O.D. (selective fitting with the cylinder block).

Piston O.D.		Piston			Cylinder block	
		S-spec	D-spec		Classification of ID	
d	+0.015 (0.0006) or less	SS	DS	→	S	D +0.0030 (0.0012) or less
	+0.005 (0.0002) or more					D +0.020 (0.0008) or more
d	less than +0.005 (0.0002)	SM	DM	→	M	D less than +0.020 (0.0008)
	-0.005 (0.0002) or more					D +0.010 (0.0004) or more
d	less than -0.005 (0.0002)	SL	DL	→	L	D less than +0.010 (0.0004)
	-0.005 (0.0006) or more					D +0.005 (0.0002) or more

d : standard diameter (Refer to Page 32.)

D : nominal diameter

- The piston is selectively fitted with the cylinder block as indicated by the arrow mark in the above. (→)
- The piston for servicing is supplied in SM or DM irrespective of I.D. of the cylinder block. (---→)

4.4 CRANKSHAFT, MAIN BEARING AND FLYWHEEL

1. Crankshaft

1) Stem color check

Clean the crankshaft and check for flaws using the color penetrant or by magnaflux inspector.

Replace the crankshaft if it is cracked or badly damaged.

2) Measuring the crank pin and journal

Check the crank pin and journal for surface wear. If the pin and journal are worn beyond the allowable limit, replace the crankshaft assembly, or grind them and fit them with an undersized bearing metal.

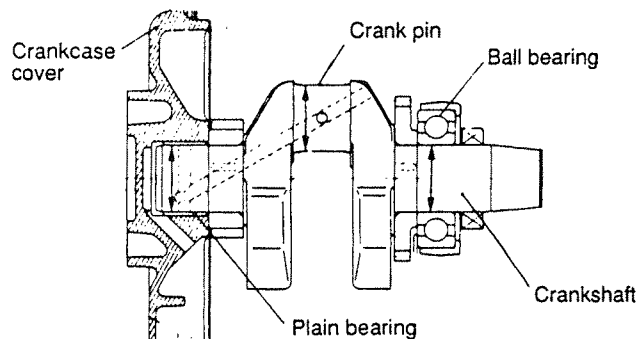

Crankshaft

mm (in.)

Item		Model	L40AE, L48AE		L60AE, L70AE		L75AE-L100AE	
			Standard	Service limit	Standard	Service limit	Standard	Service limit
Crank pin	Pin O.D.		29.965-29.982 (1.1797-1.1804)	29.90 (1.1772)	35.965-35.982 (1.4159-1.4166)	35.90 (1.4134)	39.965-39.982 (1.5734-1.5741)	39.90 (1.5709)
	Oil Clearance		0.025-0.055 (0.0010-0.0022)	—	0.025-0.055 (0.0010-0.0022)	—	0.033-0.062 (0.0013-0.0024)	—
Crank journal	Gear cover side	Journal O.D.	30.002-30.015 (1.1812-1.1817)	29.91 (1.1776)	35.002-35.018 (1.3780-1.3787)	34.91 (1.3744)	40.002-40.018 (1.5749-1.5755)	39.91 (1.5713)
		Oil clearance	0.025-0.058 (0.0010-0.0023)	0.17 (0.0067)	0.025-0.061 (0.0010-0.0024)	0.17 (0.0067)	0.025-0.061 (0.0010-0.0024)	0.17 (0.0067)
	Flywheel side	Journal O.D.	30.002-30.015 (1.1812-1.1817)	—	35.007-35.018 (1.3782-1.3787)	—	40.007-40.018 (1.5751-1.5755)	—
		Bearing I.D.	29.990-30.000 (1.1807-1.1811)	—	34.988-35.000 (1.3775-1.3780)	—	39.988-40.000 (1.5743-1.5748)	—
		Fitting	0.002-0.025 (0.00008-0.0010)	—	0.007-0.030 (0.0003-0.0012)	—	0.007-0.030 (0.0003-0.0012)	—

3) The ball bearing on the flywheel side has been press-fitted onto the crankshaft.

(Replace the crankshaft assembly if it is loosened.)

2. Main bearing metal

1) Checking the metal

(metal on the crankcase cover side)

Replace the main bearing metal if it is discolored, separated, or damaged in any other way.

The main bearing metal has been pressfitted into the crankcase cover. Align oil hole in the metal with oil groove as illustrated below.

Carefully fit the main bearing metal so that the oil groove is on the upper half.

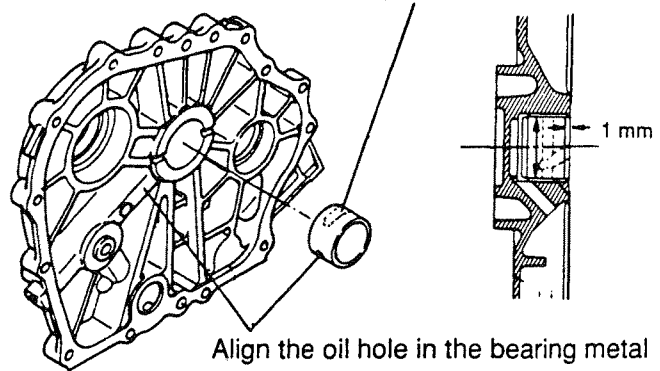

Align the oil hole in the bearing metal with the oil groove.

(Positioning the main bearing metal)

Measure an oil clearance between the main bearing metal and journal. If an oil clearance exceeds the allowable limit, add an undersized bearing metal shown below.

CAUTIONS:

1. Mount the metal so that the oil groove faces up.
2. The sinkage should be 1 mm (0.0394 in.) from the thrust surface.

(Under-size crank pin metal, Part No.)

Item	Model	L40AE, L48AE	L60AE, L70AE	L75AE-L100AE
Standard		114250-02100	114350-02100	114650-02100
Under-size 0.25 mm (0.0098 in.)		114250-02200	114350-02200	114650-02200
Under-size 0.50 mm (0.0197 in.)		114250-02210	114350-02210	114650-02210

3. Flywheel

1) Timing mark

Fuel injection timing mark for measurement are on the periphery of the flywheel.

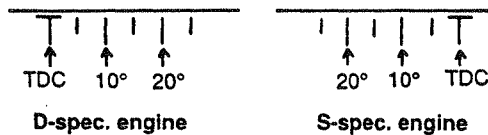
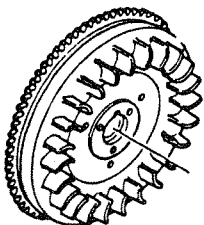

2) Ring gear

Ring gear has been shrinkage-fitted on the flywheel at approx. 180°C (356°F).

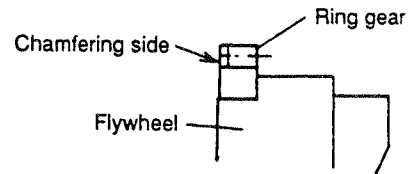

4.5 CAMSHAFT AND TAPPET

1. Camshaft

- 1) Checking the clearance at the thrust of the camshaft (cylinder block side)

Check the clearance at the thrust of the camshaft. The camshaft bearing has been press-fitted into the cylinder block. Maintain the sinkage between the pressfitted bearing face and the thrust surface of cylinder block at 1.4~1.5 mm.

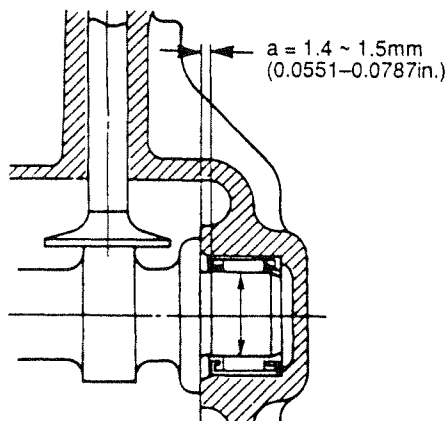

(Cam shaft thrust clearance)

- 2) Measuring the camshaft and bearing (Crankcase cover side)

Measure the I.D. of the ball bearing and O.D. of the camshaft. Replace to ball bearing if it exceeds the wear limit or is badly damaged.

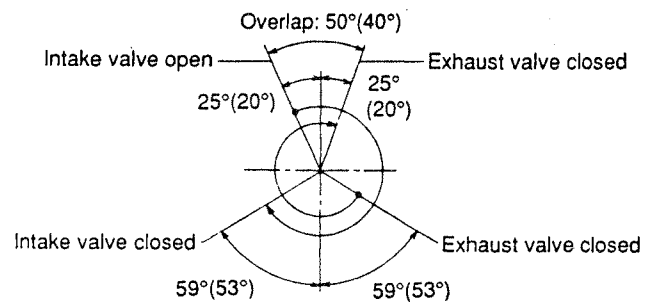

Valve timing
(valve clearance in cold state: at 0.15mm)

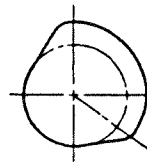

Shape of fuel cam
(Reverse preventive type)

Camshaft

mm (in.)

Model		L40AE, L48AE		L60AE, L70AE		L75AE-L100AE	
Item		Standard	Service limit	Standard	Service limit	Standard	service limit
Needle bearing on cylinder block side	Shaft O.D.	14.989-15.000 (0.5901-0.5906)	14.92 (0.5874)	14.989-15.000 (0.5901-0.5906)	14.92 (0.5874)	14.989-15.000 (0.5901-0.5906)	14.92 (0.5874)
	Bearing I.D.	15.016-15.034 (0.5912-0.5919)	—	15.016-15.034 (0.5912-0.5919)	—	15.016-15.034 (0.5912-0.5919)	—
	Oil clearance	0.016-0.045 (0.0006-0.0018)	—	0.016-0.045 (0.0006-0.0018)	—	0.016-0.045 (0.0006-0.0018)	—
Ball bearing on crankcase cover side	Stem O.D.	24.980-24.993 (0.9835-0.9840)	24.90 (0.9803)	29.980-29.993 (1.1803-1.1808)	29.90 (1.1772)	34.980-34.993 (1.3772-1.3777)	34.90 (1.3740)
	Bearing I.D.	24.990-25.000 (0.9839-0.9843)	25.02 (0.9850)	29.990-30.000 (1.1807-1.1811)	30.02 (1.1819)	34.990-35.000 (1.3776-1.3780)	35.02 (1.3787)
	Oil clearance	0.020-0.030 (0.0008-0.0012)	—	0.020-0.030 (0.0008-0.0012)	—	0.020-0.030 (0.0008-0.0012)	—
Thrust clearance		0.040-0.280 (0.0016-0.0110)	0.45 (0.0177)	0.040-0.280 (0.0016-0.0110)	0.45 (0.0177)	0.040-0.280 (0.0016-0.0110)	0.45 (0.0177)

2. Tappet

- 1) Check the condition of the tappet contact point. The tappet is offset with regard to the cam center and rotated during operation to prevent uneven wear. Replace the tappet if it is badly worn or contacts the cam unevenly.
- 2) Check the outer surface of the tappet for wear and damage. Replace if defective.

CAUTION:

Keep the intake and exhaust tappets separate in disassembling or reassembling them.

Tappet

mm (in.)

Model		L40AE-L100AE	
Item		Standard	Service limit
Intake • Exhaust Tappet	Stem O.D.	6.960-6.980 (0.2740-0.2748)	6.87 (0.2705)
	Hole dia. (Cylinder block)	7.000-7.015 (0.2756-0.2762)	7.06 (0.2780)
	Oil clearance	0.020-0.055 (0.0008-0.0022)	—
Fuel Injection Pump Tappet	O.D.	23.972-23.993 (0.9438-0.9446)	23.89 (0.9405)
	Hole dia. (Cylinder block)	24.000-24.033 (0.9449-0.9462)	24.06 (0.9472)
	Oil clearance	0.007-0.061 (0.0003-0.0024)	—

4.6 TIMING GEARS

1. Checking the timing gears

- 1) Check each gear and replace those that are damaged or worn.
- 2) When reassembling, line up the timing marks on each gear.

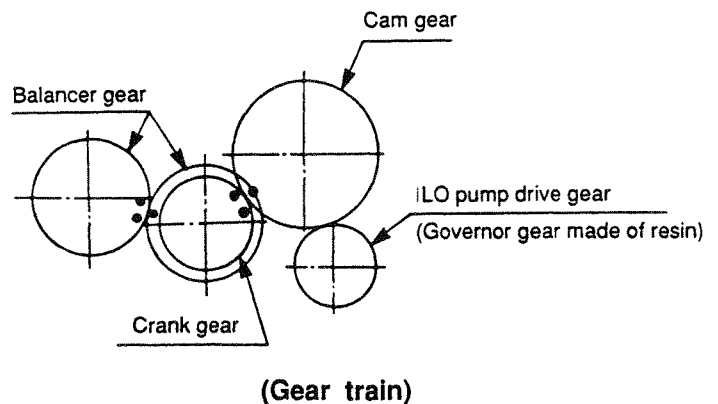

4.7 CRANKCASE COVER

Always handle the aluminum packing with care. When the crankcase cover is disassembled, replace the aluminum packing on the crankcase cover if damaged or deformed. Be sure to tighten the crankcase cover to the tightening torques as specified below. The crankcase cover is held in position by two knock pins.

Tightening torque kg-cm (lb-ft)

Model	L40AE, L48AE	L60AE-L100AE
Crankcase cover	100-120 (7.2-8.7)	200-230 (14.5-16.6)
Stiffener bolt	200-230 (14.5-16.6)	

1. Cleaning and checking

Clean the cylinder block when the engine is overhauled. Clean out each oil hole and make sure it is not clogged. (Leave plugs in place if they do not need to be replaced. Protect the plugs from oil leaks.)

S-spec. engine

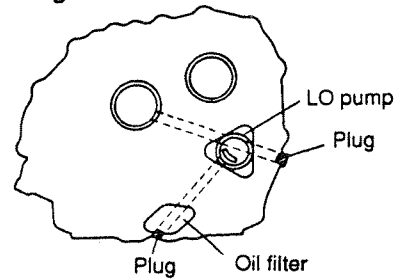

D-spec. engine

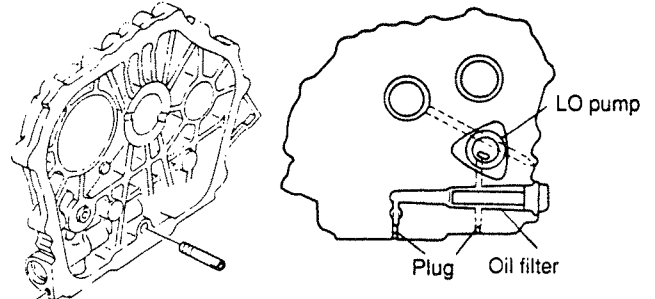

(Oil hole and blind cover of the crankcase)

Crankcase cover

mm (in.)

Item		L40AE, L48AE		L60AE, L70AE		L75AE-L100AE	
		Standard	Service limit	Standard	Service limit	Standard	Service limit
Crankshaft bearing part	I.D.	34.000-34.025 (1.3386-1.3396)	—	39.000-39.025 (1.5354-1.5364)	—	44.000-44.025 (1.7323-1.7333)	—
	Bearing O.D. (Plain)	34.070-34.105 (1.3413-1.3427)	—	39.070-39.105 (1.5382-1.5396)	—	44.085-44.120 (1.7356-1.7370)	—
	Fitting	0.045-0.105 (0.0018-0.0041)	—	0.045-0.105 (0.0018-0.0041)	—	0.060-0.120 (0.0024-0.0047)	—
	Bearing metal I.D. (Plain metal)	30 (1.1811)	30.13 (1.1862)	35 (1.3780)	35.13 (1.3831)	40 (1.5748)	40.13 (1.5800)
Camshaft bearing part	I.D.	51.945-51.965 (2.0451-2.0455)	—	61.940-61.960 (2.4386-2.4394)	—	71.935-71.955 (2.8321-2.8329)	—
	Ball bearing O.D.	51.987-52.000 (2.0467-2.0472)	—	61.987-62.000 (2.4404-2.4409)	—	71.987-72.000 (2.8341-2.8346)	—
	Fitting	0.022-0.055 (0.0009-0.0022)	—	0.027-0.060 (0.0011-0.0024)	—	0.032-0.065 (0.0013-0.0026)	—

The S specification differs from the D specification in the direction in which the Lub. oil filter is extracted, for the purpose of facilitating maintenance of the crank case cover.

mm (in.)

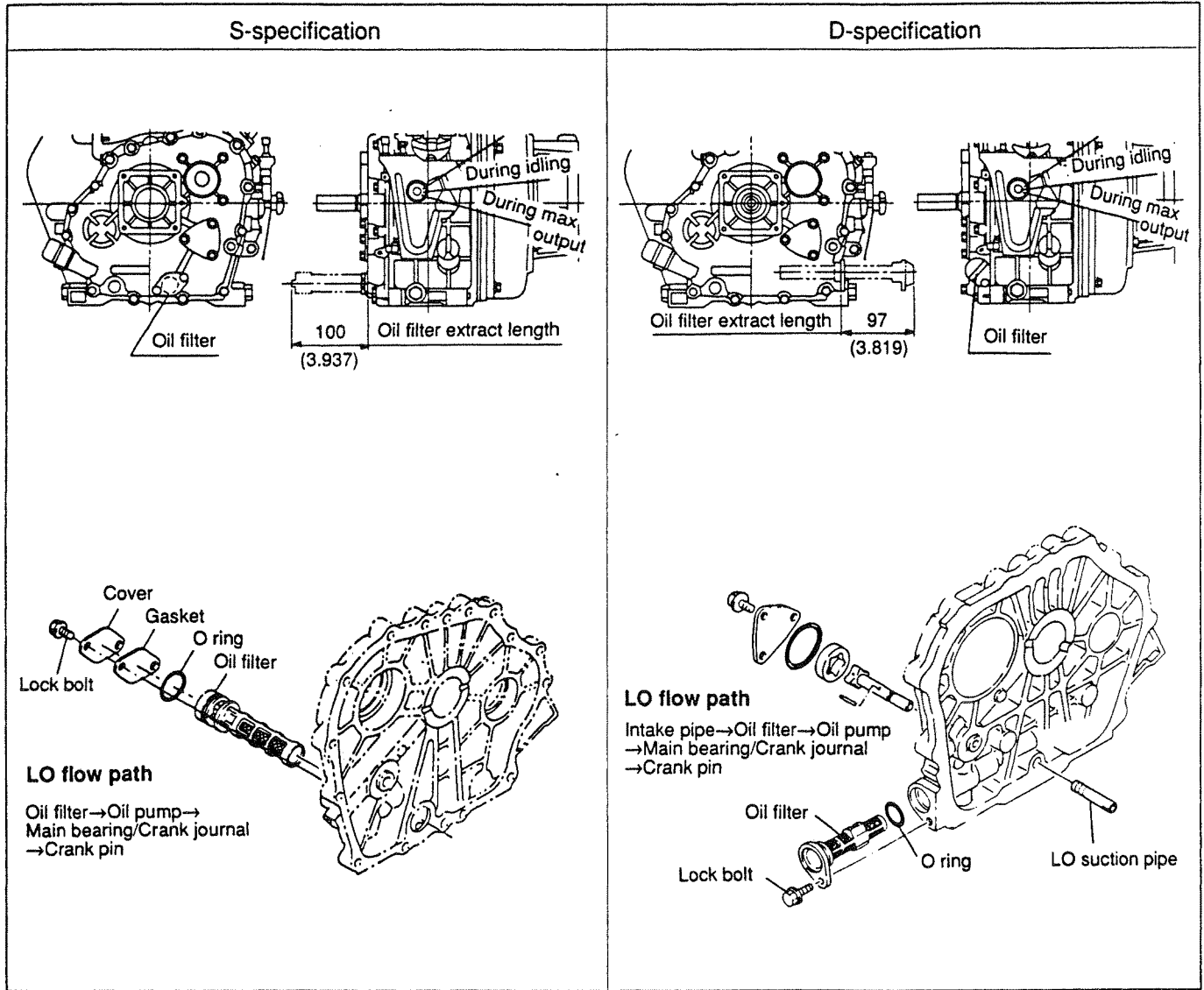

2. Replacing the crankshaft oil seal and camshaft oil seal

When replacing oil seal, use special tool.

Insert crankshaft oil seal into crankcase cover until it is 4 mm (0.1575 in.) deep from the end of crankcase.

Insert camshaft oil seal into crankcase cover flush with the end of crankcase. When inserting crankshaft oil seal into cylinder block, insert it flush with the end of cylinder block.

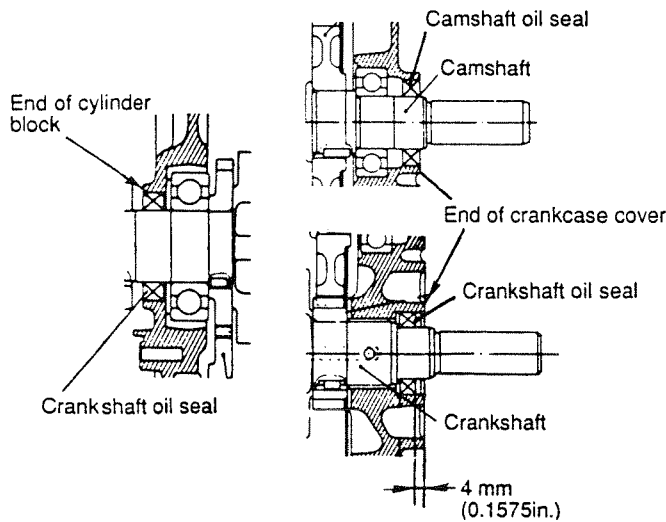

4.8 CYLINDER SLEEVE AND CYLINDER BLOCK

1. Cylinder sleeve

The cylinder sleeve (FC25S) is cast in the aluminum die-casting cylinder block.

Measure the I.D. of the cylinder sleeve. Re-bore the cylinder sleeve if it exceeds the allowable limit and use with an oversized piston.

mm (in.)

Oversize piston	0.25 (0.0098)
	0.50 (0.0197)

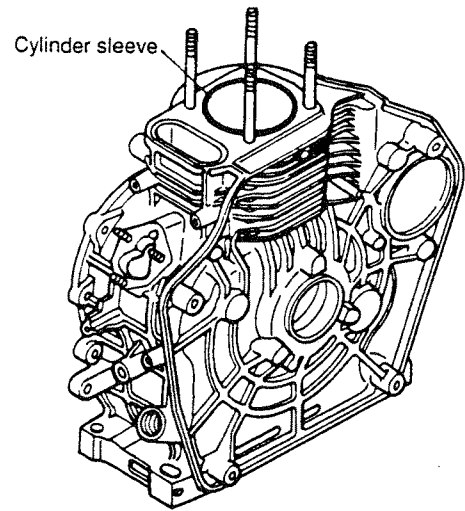

(Cylinder block and cylinder sleeve)

2. Cylinder block

mm (in.)

Model		L40AE, L48AE		L60AE, L70AE		L75AE-L100AE	
		Standard	Service limit	Standard	Service limit	Standard	Service limit
Crankshaft bearing part	I.D.	71.9905-72.0095 (2.8343-2.8350)	—	79.980-79.996 (3.1488-3.1494)	—	89.984-90.000 (3.5427-3.5433)	—
	Ball bearing O.D.	71.987-72.000 (2.8341-2.8346)	—	79.987-80.000 (3.1491-3.1496)	—	89.985-90.000 (3.5427-3.5433)	—
	Fitting	0.0225-0.0095 (0.00089-0.00037)	—	0.009-0.020 (0.00035-0.00079)	—	0.015-0.016 (0.00059-0.00063)	—
Camshaft bearing part I.D.		20.957-20.978 (0.8251-0.8259)	—	20.957-20.978 (0.8251-0.8259)	—	20.957-20.978 (0.8251-0.8259)	—

Cylinder sleeve I.D. mm (in.)

Model	Standard	Servie limit
L40AE	68.000–68.030 (2.6771–2.6783)	68.16 (2.6835)
L48AE	70.000–70.030 (2.7559–2.7571)	70.16 (2.7622)
L60AE	75.000–75.030 (2.9528–2.9539)	75.18 (2.9598)
L70AE	78.000–78.030 (3.0709–3.0720)	78.18 (3.0779)
L75AE	80.000–80.030 (3.1469–3.1509)	80.18 (3.1567)
L90AE	84.000–84.030 (3.3071–3.3083)	84.18 (3.3142)
L100AE	86.000–86.030 (3.3858–3.3870)	86.18 (3.3929)

4.9 LUBRICATION SYSTEM

This engine adopts a forced oil lubrication system driven by a trochoid pump. Lubricating oil is circulated as follows. The rocker arm chamber is lubricated by moisture.

LO filter → Trocoid pump → Crankshaft → Crankpin metal

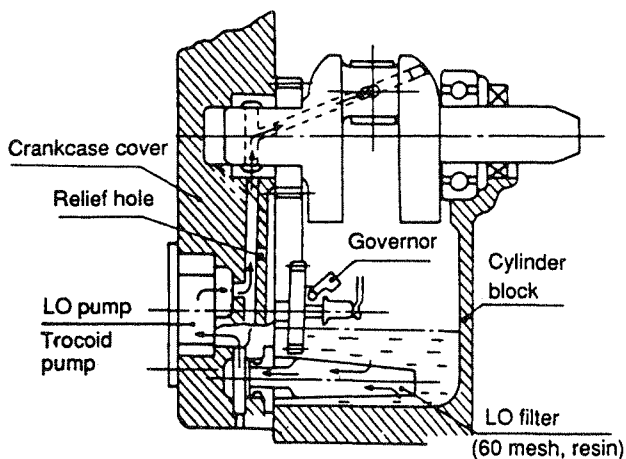

(Lubricating oil route)

1. Lubricating oil pump

- 1) Measure the clearance between the outer rotor and body (crankcase cover). Replace the pump if the clearance exceeds the allowable limit.
- 2) Measure the clearance between the outer rotor and the inner rotor with a thickness guage. Replace the pump as a set if the clearance exceeds the allowable limit.
- 3) Installing the lubricating oil pump
 - (1) Insert the lubricating oil pump assembly ① from the outside of the crankcase cover. Coat the rotor with oil before installing the cover.
 - (2) Insert the parallel pin ② into the lubricating oil pump shaft.
 - (3) Set the weight ③ on the gear.
 - (4) Insert the spindle into the weight, then push the spindle into the shaft. Once in place, the spindle cannot be removed.

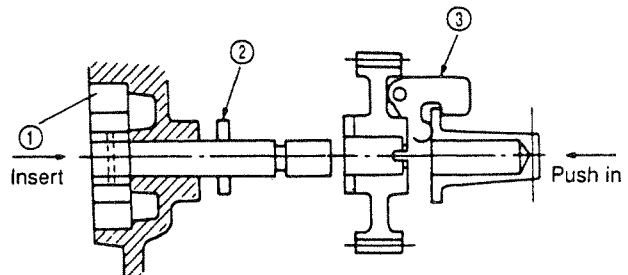

(Installation of lubricating oil pump)

Oil pump

mm (in.)

Item		Model	L40AE-L100AE	
			Standard	Service limit
Outer	Outer rotor O.D.		28.96-28.98 (1.1402-1.1409)	28.90 (1.1378)
	Housing I.D. (Crankcase cover)		29.100-29.121 (1.1457-1.1465)	29.18 (1.1488)
	Clearance between housing I.D. and outer rotor O.D.		0.120-0.161 (0.0047-0.0063)	—
Width	Outer and Inner rotor width		7.97-8.00 (0.3138-0.3150)	7.90 (0.3110)
	Housing depth		8.02-8.05 (0.3157-0.3169)	8.10 (0.3189)
	Clearance between housing and inner/outer rotors		0.02-0.08 (0.0008-0.0031)	—
Clearance between the inner and outer rotor			< 0.14 (0.0055)	0.25 (0.0098)

4.10 FUEL SYSTEM

1. Fuel injection pump

1) Specifications

Model: YPFE-M

Model		L40AE	L48AE	L60AE	L70AE	L75AE	L90AE	L100AE
Stamped mark	Bare engine	40S	48S	60S	70S	75S	90S	100S
	Generator set	40D	48D	60D	70D	75D	90D	100D

CAUTION:

1. The ID marks for stamped the pump is on the pump mounting flange.
2. None of these fuel injection pumps is interchangeable.
3. The fuel injection pump for discrete engine differs from the generator in the direction of the fuel inlet pipe.

	L40AE-L100AE
Adjusting Shims Standard thickness (shop assembly)	0.5 (0.0197)

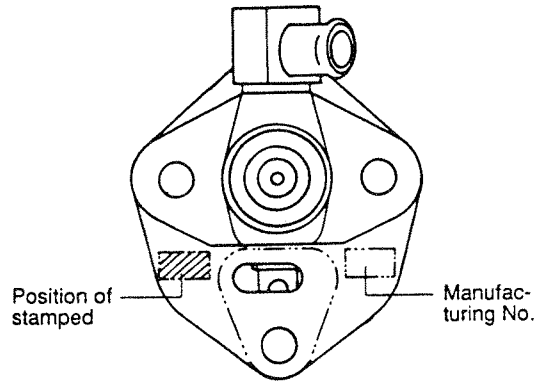

Fuel pump mounting flange

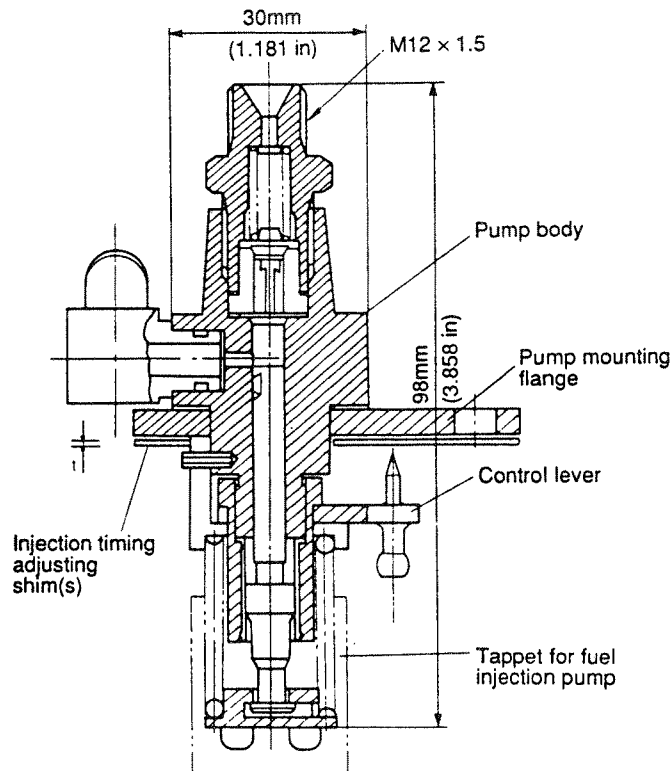

(Configuration of fuel oil pump)

3) Disassembly and reassembly

This is standard fuel injection pump body. Disassemble and reassemble the fuel pump in the direction order of "UP", "DOWN" and "SIDE" from the center of the fuel injection pump body (marked "C") as illustrated. Reassemble the gasket A and B for the delivery seat in the position at the time of disassembly.

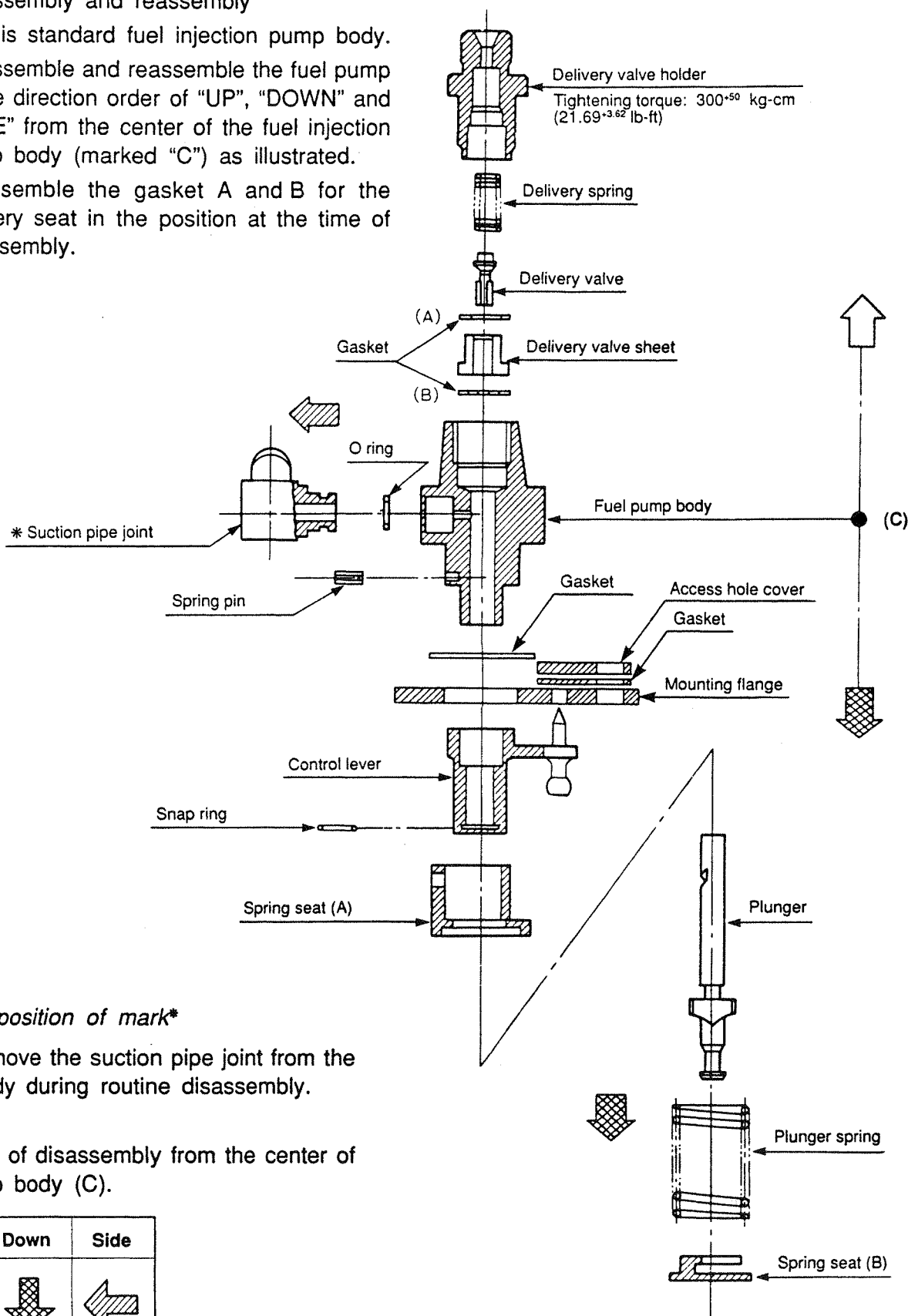

NOTE:

See the position of mark*

Never remove the suction pipe joint from the pump body during routine disassembly.

Symbols:

Directions of disassembly from the center of fuel pump body (C).

Up	Down	Side
↑	↓	←

(Fuel pump disassembly and reassembly)

2. Fuel injection valve

1) Specifications Model: YDLLA-P

Item \ Specification	L40AE/48AE	L60AE/L70AE	L75AE – L100AE
Mark to identify assembly ①	AB	AN	AF
Mark to identify nozzle valve and nozzle body ②	YANMAR 150P 224A1	YANMAR 150P 214B0	YANMAR 150P 224B0

Example:

Symbol 150P indicates an injection angle of 150°; symbol 224A1 implies 4 nozzle holes which are 0.22 mm in injection hole diameter.

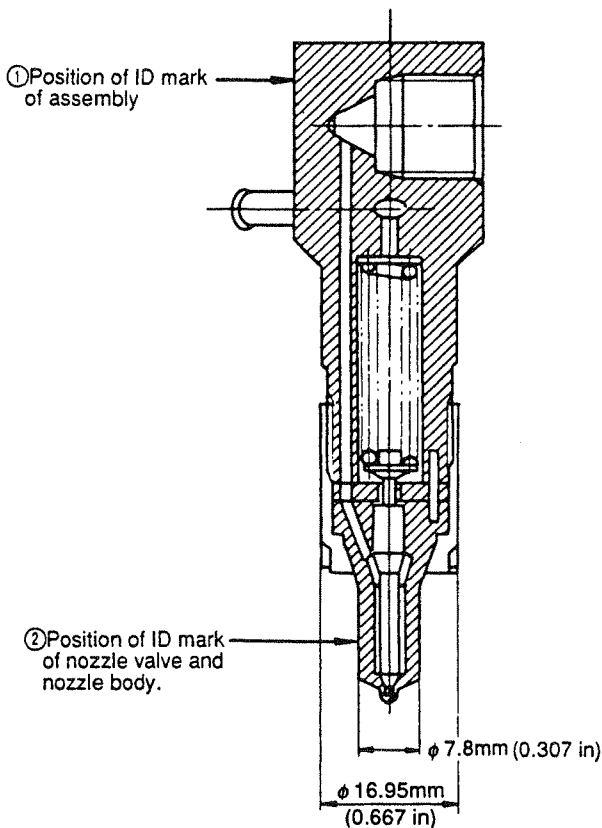

(Structure of injection valve)

CAUTION:

- When replacing fuel injection valve, be sure to check engine model against the identity marks shown above. Any injection valve is least identifiable in appearance.
- When removing the fuel injection valve, wrap it in cloth to protect the nozzle tip (injection port). Do not place the nozzle tip directly on the ground.

2) Check

(1) Carbon deposits

(Flowering)

Carbon deposits build up on the nozzle in the form of flowers. Flowering lowers combustion performance significantly. Make sure the nozzle is free from contamination.

(2) Shape of injection spray

Move the lever of the nozzle tester at a speed of approx. 1.2 time/sec. to check the spray pattern.

Normal shape of spray

- The spray should all be at the same angle.
(from all four injection ports)
- The spray should be a fine mist.
- The spray should be smooth and steady without deviations.
(4 nozzles)

3) Cautions when installing fuel injection valve

- Tighten the fuel injection valve assembly to the specified torque.
- Clean the sleeve surface. Be sure to replace the nozzle gasket at the same time.

Note:

If nozzle gasket stays in cylinder head after injection valve assembly has been removed from cylinder head, screw M8 or M9 stud bolt (more than 100 mm long) in nozzle gasket, then pull out stud bolts to remove gasket.

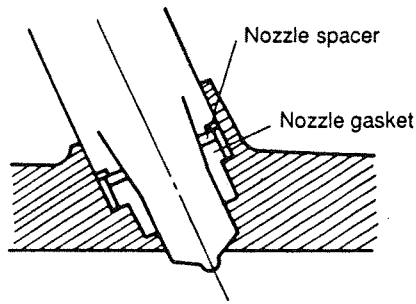

(Fuel injection nozzle)

Tightening torque		kg-cm (lb-ft)
Item	Model	L40AE~L100AE
Installing fuel injection valve nut		100-120 (7.2-8.7)
Fuel injection nozzle case nut		400-450 (28.9-32.5)

4) Disassembly and reassembly

Remove the case nut, and then all parts of the valve can be disassembled.

To disassemble and reassemble the case nut, use a 15 mm deep socket wrench.

The fuel valve positioning pin does not need to be removed in most cases.

5) Adjustment

The injection starting pressure is 200 kg. To adjust the nozzle injection starting pressure, remove the nozzle holder and increase or decrease the number of adjusting shims.

Adjustment by 0.1 mm results in a change in the injection starting pressure of about 20 kg/cm².

Adjusting shims come in the following thicknesses: 0.1, 0.15, 0.4, 0.5, 0.6, 0.7, and 0.8 mm.

		mm (in.)
		L40AE-L100AE
Adjusting shim standard thickness		0.60-0.65 (0.0236-0.0256)

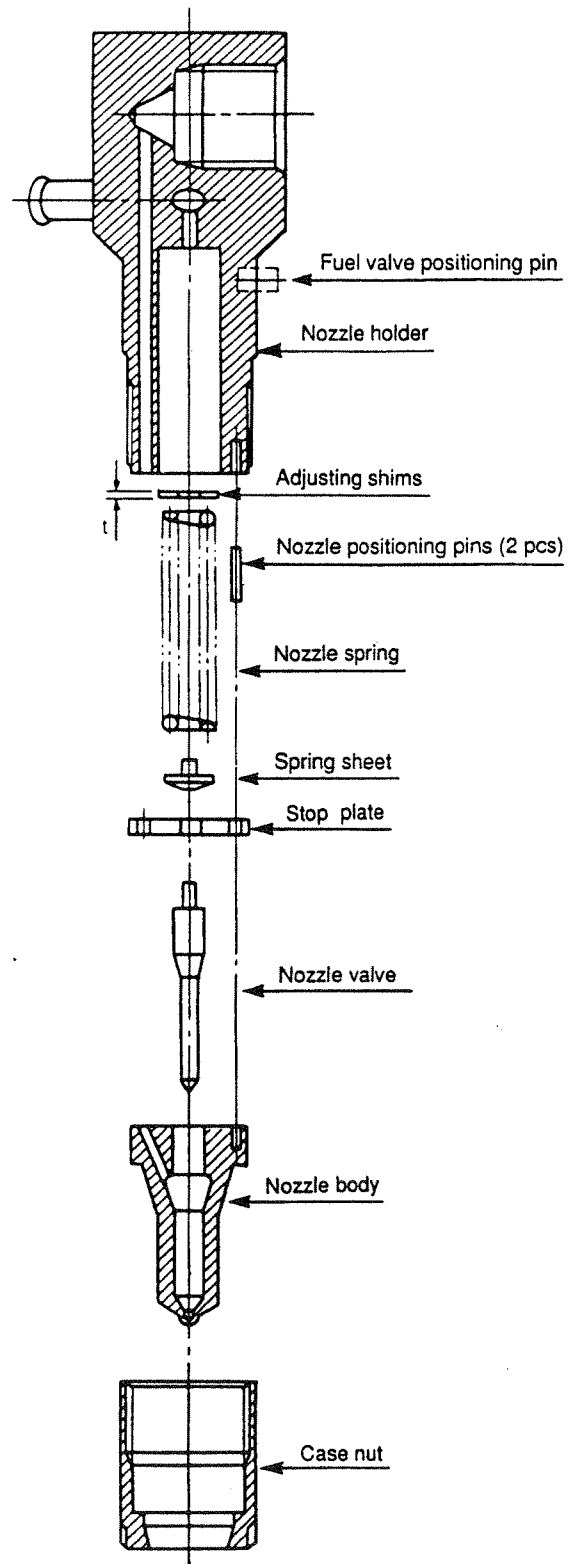

(Fuel injection valve assembly)

3. Fuel filter

The fuel filter uses an element of nominal filterable particle diameter of 5 μ . During the periodical inspection of this part, check the element for break, separation from the frame to which it should be bonded, stoppage, etc., and if a defection is found, replace it with new one. To detach the fuel filter, first remove the filter cap on fuel tank, then pull out it from the fuel filler port. But pull the filter down-wards for YDG (generator set), YLP, and YDP (pump set).

4.11 SPEED CONTROL DEVICE

The position where governor spring must be installed differs depending on engine model and its rated rpm as shows in the following table and illustrated.

Check the spring for position before ascertaining the fuel injection limit.

Position of Governor Spring Hole

Model and Application Type of speed control device	Location of governor spring installation hole			
	L40AE~L70AE		L75AE~L100AE	
	3600 rpm (60 Hz)	3000 rpm (50 Hz)	3600 rpm (60 Hz)	3000 rpm (50 Hz)
A Speed variable, regulator handle revolution/ fixed type (remote controllable)	2 - b	2 - c	3 - b	3 - c
B Remote control type				
C Speed variable, (friction plate type)	1 - b	1 - c	1 - b	1 - c
D Constant revolution, lock lever type	1 - b	2 - c	1 - b	2 - c

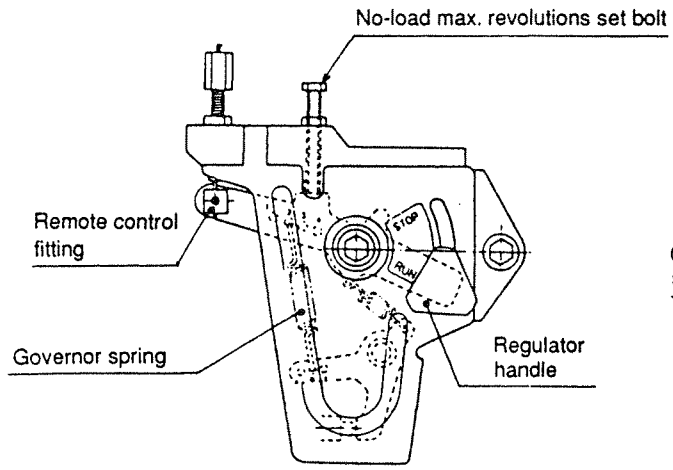

(Type A)

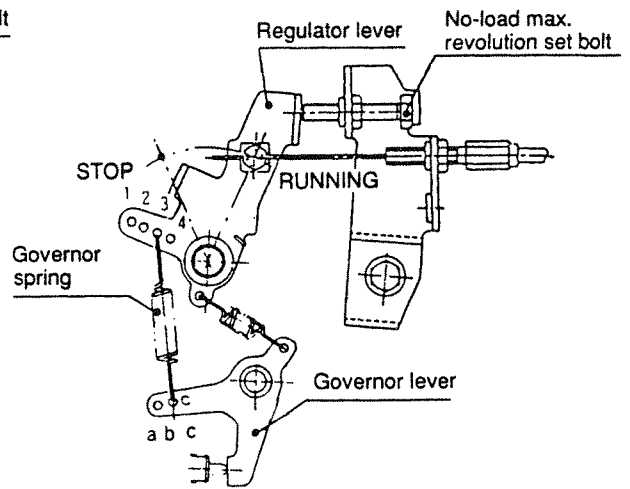

(Type B)

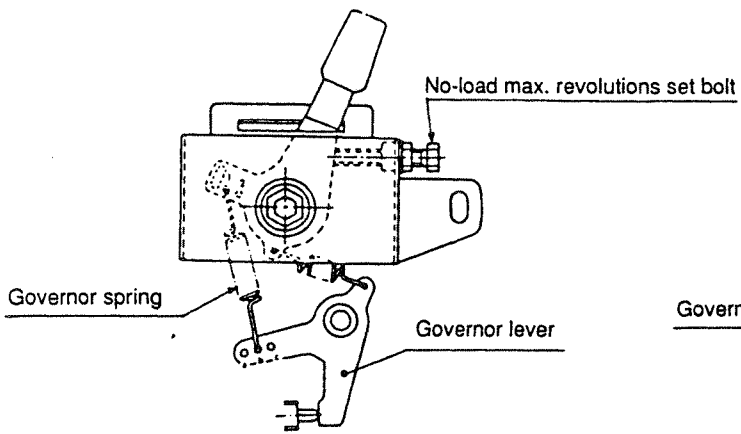

(Type C)

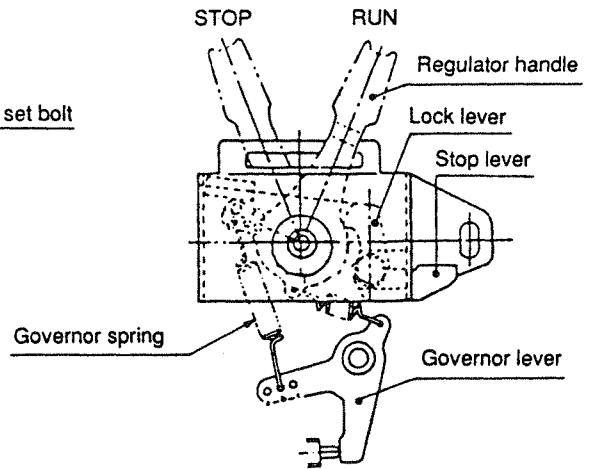

(Type D)

4.12 ELECTRICAL SYSTEM

1. Wiring Diagrams

L40AE – L100AE ENGINES WIRING DIAGRAM

For 12V-15A/12V-3A Charging Generator

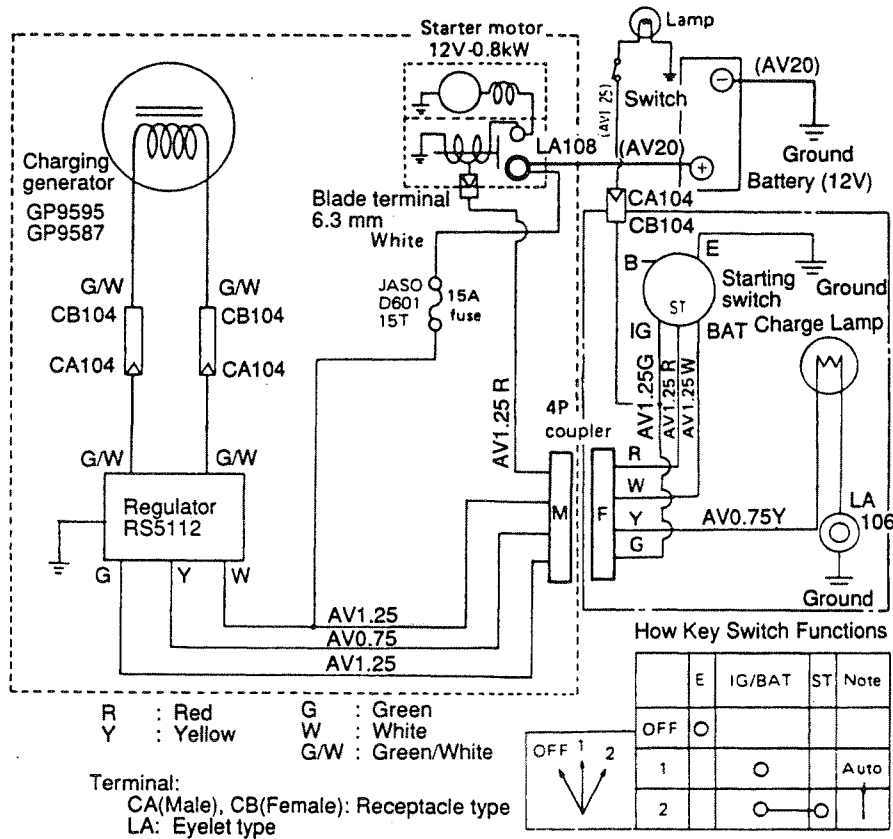

Notes:

Charging generator	Model	GP9595	GP9587
	Output current * (at 3600 rpm)	14.8 – 16A (DC) (at 12V)	2.6 – 3.3A (DC) (at 13V)
At charging * start	or less 1000 rpm (at 12V)	or less 1000 rpm (at 13V)	
Allowable ambient temperature	-20 – +65°C	-20 – +65°C	
Combination of regulator (Model)	RS5112	RS5112	
Starting motor	12V – 0.8kW		
Useable lamp (max.) (at 3600 rpm)	12V – 150W	12V – 25W	

An asterisk (*) indicates a characteristic in warm state (ambient temperature 20°C)

- Be sure to ground both engine and engine-driven machine.
- Section enclosed with dotted square is pre-wired at Yanmar factory.
 Section enclosed with alternate long and short dash line is the section included in engine packing. For this section, purchaser is expected to:
 - Connect 4P coupler.
 - Secure charge lamp ground (LA106) with bolt (M6).
- Locally procure:
 - Battery; L40AE, 48AE: 18 – 24 AH, L60AE, 70AE: 24 – 36 AH, L75AE – 100AE: 36 – 45 AH.
 - Battery, cable; ⊕ & ⊖ (AV20), lamp, switch and cable (AV1.25).
- Take off power for the lamp through the female box terminal (CB104). Procure the lamp and switch at your specification.
- 13V – 3.0A $\frac{3}{2}$ A (engine revolution 3600 rpm, 20°C)
 13V – 1.1A $\frac{3}{2}$ A (engine revolution 1400 rpm, 20°C)
- Length of wiring harness between key switch and 4P coupler is 700 mm (29.134 in.)
- When installing the engine according to the vibration-proof specification, use the cable in sufficient length to prevent disconnection.

L40AE – 100AE ENGINES WIRING DIAGRAM

For 12V – 3A Charging Generator

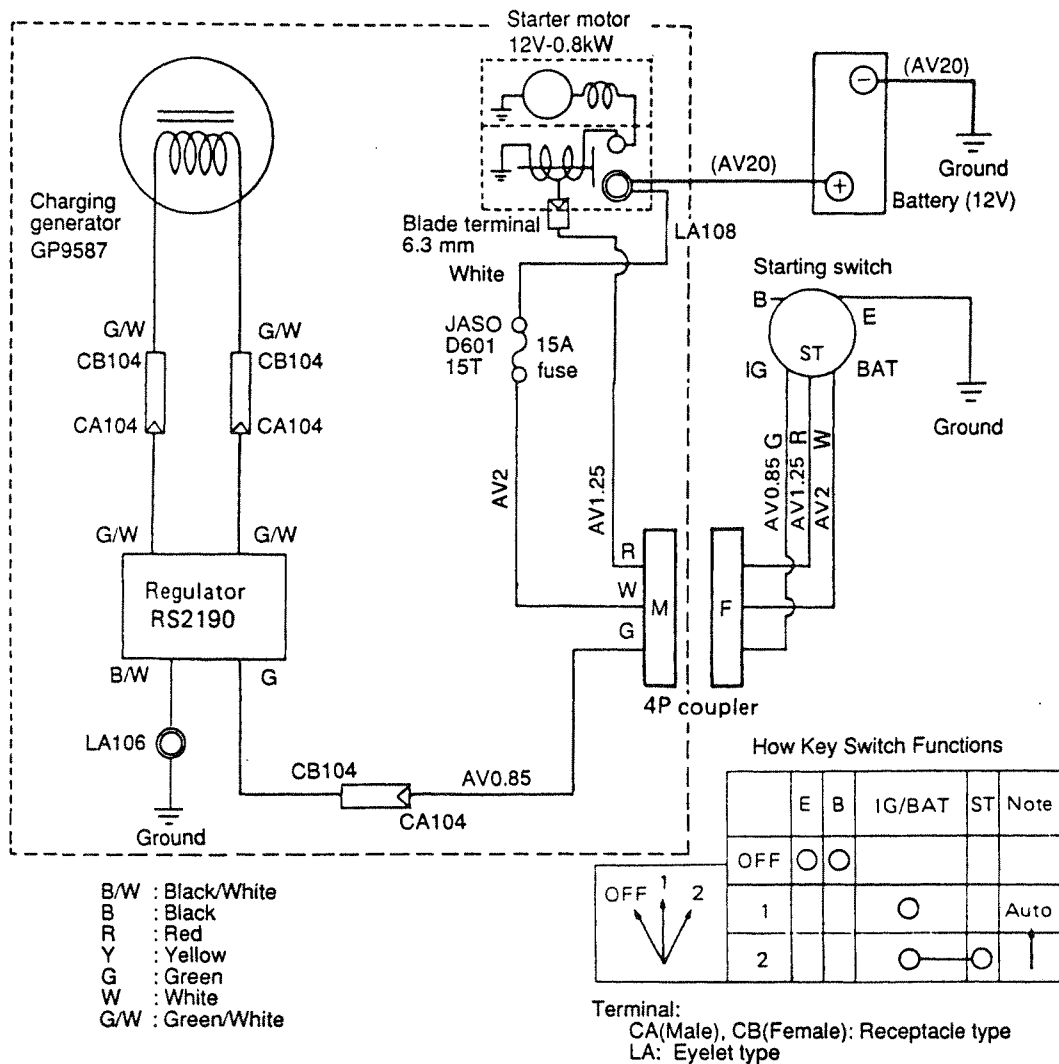

Notes:

Model	GP9587
Output current * (at 3600 rpm)	2.6 – 3.3A (DC) (at 13V)
At charging * start	or less 1000 rpm (at 13V)
Allowable ambient temperature	-20 – +65°C
Combination of regulator (Model)	RS2190
Starting motor	12V – 0.8kW

An asterisk (*) indicates a characteristic in warm state (ambient temperature 20°C)

1. Be sure to ground both engine and engine-driven machine.
2. Section enclosed with dotted square is pre-wired at Yanmar factory.
3. Locally procure:
 - 1) Battery; L40AE/L48AE: 18–24AH, L60AE/70AE: 24–36AH, L75AE~L100AE: 36 – 45 AH.
 - 2) Battery cable; ⊕ & ⊖ (AV20)
 - 3) Starting switch and 4P coupler.

L40AE – 100AE ENGINE WIRING DIAGRAM

For 12V – 1.7A Charging generator

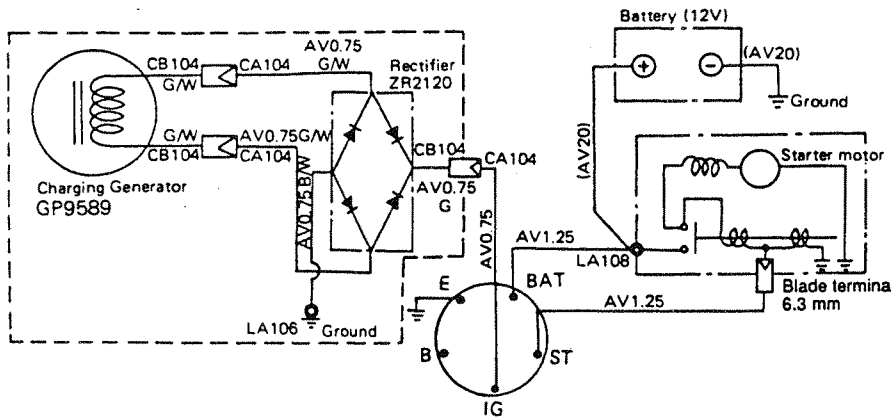

For 12V - 1A Charging generator

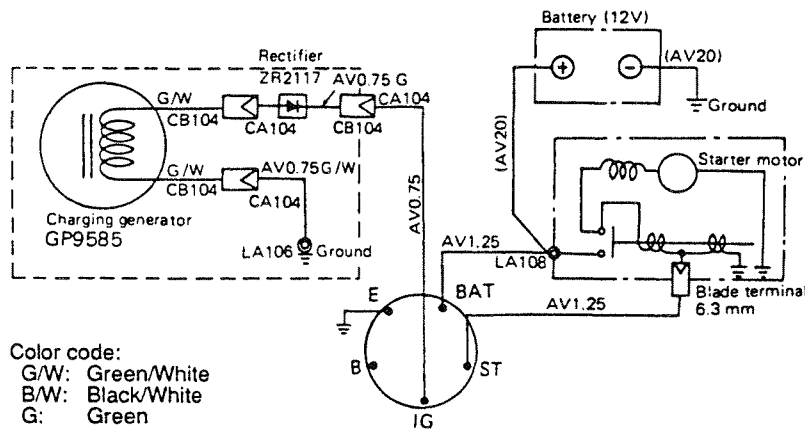

Color code:
 G/W: Green/White
 B/W: Black/White
 G: Green

Terminal:
 CA(Male), CB(Female) : Receptacle type
 LA: Eyelet type

Notes:

Charging generator	Model	GP9595	GP9587
	Output current * (at 3600 rpm)	1.6 – 1.8A (DC) (at 12V)	0.7 – 1.3A (DC) (at 13V)
	At charging * start	or less 1000 rpm (at 13V)	or less 1500 rpm at 13V
	Allowable ambient temperature	-20 – +65°C	-20 – +65°C
	Combination of regulator (Model)	ZR2120	RS2117
Starting motor		12V – 0.8kW	

An asterisk (*) indicates a characteristic in warm state (ambient temperature 20°C)

1. Be sure to ground both engine and engine-driven machine.
2. Section enclosed with dotted square is pre-wired at Yanmar factory.
3. Locally procure 1) battery 2) battery cable 3) starting switch and 4) cables.

Battery: L40AE, 48AE 18 – 24 AH
 L60AE, 70AE 24 – 36 AH
 L75AE-100AE 36 – 45 AH

Battery cable: ⊕ & ⊖ AV20

L40AE – 100AE ENGINES WIRING DIAGRAM (with air heater and timer)
For 12V – 15A/12V – 3A Charging Generator

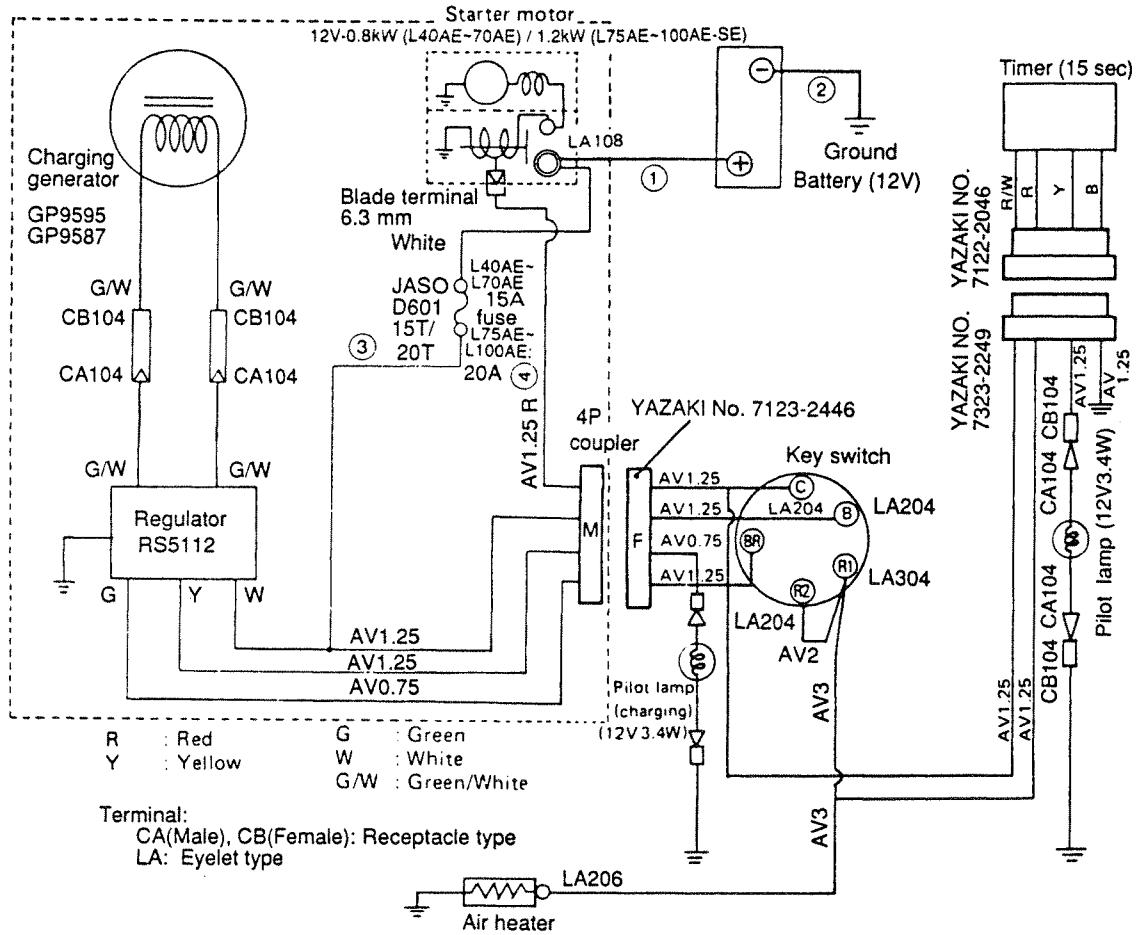

1. Be sure to ground both engine and engine-driven machine.
2. Section enclosed with dotted square is pre-wired at Yanmar factory.
3. Battery; L40AE/48AE: 30AH, L60AE/70AE: 35AH, L75-100AE: 45AH.
4. Battery cable (① + ②): AV20 ... <1.3m, AV30 ... <2.3m
5. Starter cables ③ and ④ shall have total resistance below 5/100 Ω, provided that terminal resistance shall have 15/1000 Ω per connector while screw-in connector 0 Ω

Key switch connections

	B	R1	R2	BR	C
Pre-heating	○	○	○	○	
OFF	○				
ON	○	○	○	○	
Starting	○	○	○	○	○

L40AE – L70AE ENGINES WIRING DIAGRAM

Generator for Lighting

For 12V-25W/40W (Use lamp only)

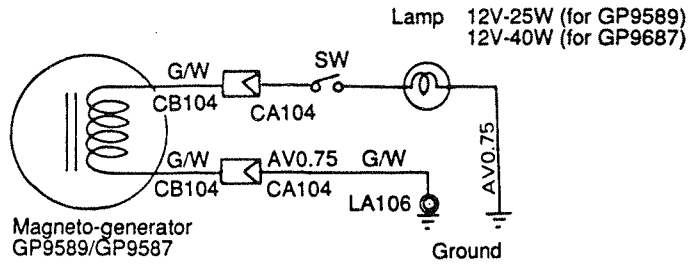

For 6V-15W (Use Lamp only)

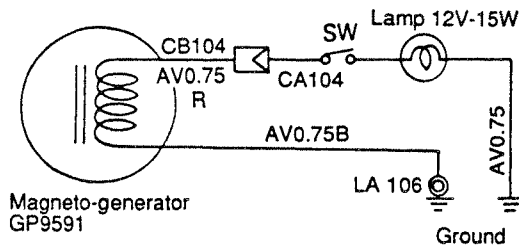

Notes:

1. Use Lamp only.
2. For Recoil starting specification engine
3. Color code

G/W: Green/White

R: Red

B: Black

Terminal:

CA(Male), CB(Female): Receptacle type

LA: Eyelet type

2. Starter Motor

Type of starter motor

Starter motors are roughly divided into the common type (conventional type) and reduction type; they are subdivided into the Bendix type and magnetic shift type (The clutch is available in the

roller clutch type and multi-plate clutch type.) depending on pinion engagement mechanisms. The L-A series uses the common type, magnetic shift system starter motor as standard.

1. Specifications and Performance

Engine model	L40AE-SE ~ L100AE-SE	L40AE-DE ~L100AE-DE	L75AE-SE~L100AE-SE (Optional)
Type	Conventional		Reduction type
Model	S114 - 413A	S114 - 414A	S114 - 478
Rating (sec.)	30		←
Output (V-kW)	12 - 0.8		12 - 1.2
Direction of rotation (viewed from pinion side)	Clockwise	Counterclockwise	Clockwise
Weight kg (lb.)	3.6 (7.9)		4.4 (9.7)
Clutch system	Over running		←
Engagement system	Magnetic shift		←
No. of pinion teeth	8		←
Pinion coming out voltage (V)	8		←
No-load	Terminal voltage (V)	11.5	12
	Current (A)	60 (Max.)	105 (Max.)
Loaded characteristics	Speed (rpm)	7000 (Min.)	4000 (Min.)
	Terminal voltage (V)	8	8.7
	Current (A)	200	←
	Torque kg-m (ft.-lb)	0.32 (2.31)/1850 rpm (Min.) (Min.)	0.46 (3.33)/1550 rpm (Min.) (Min.)

Characteristics Curve

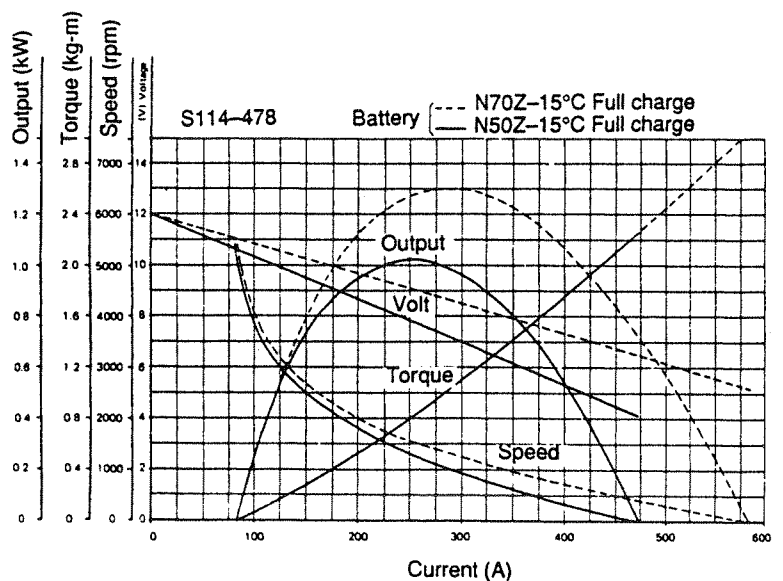
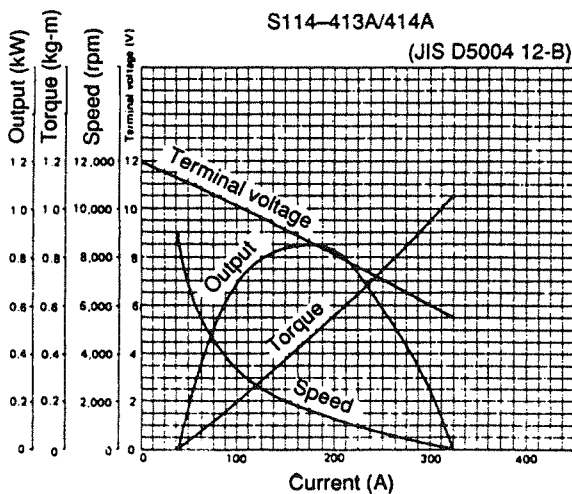

2. Construction

The starter motor is composed of three major parts, as follows:

1) Magnetic switch

Moves plunger to engage and disengage pinion and, through the engagement lever, opens and closes the main contact (moving contact) to start and stop the starter motor.

2) Motor

A continuous current series motor which generates rotational drive power.

3) Pinion

Transfers driving power from motor to ring gear. An over-running clutch is employed to prevent damage if the engine runs too fast.

The overrun clutch is composed of the roller and clutch outer, as illustrated below. The roller is held down the roller in tapered part.

The overrun clutch is composed of the roller and clutch outer, as illustrated below. The roller is kept pressed by the roller spring. The clutch outer houses the roller in tapered part.

2.1 Conventional type starter motor (Standard electric starter)

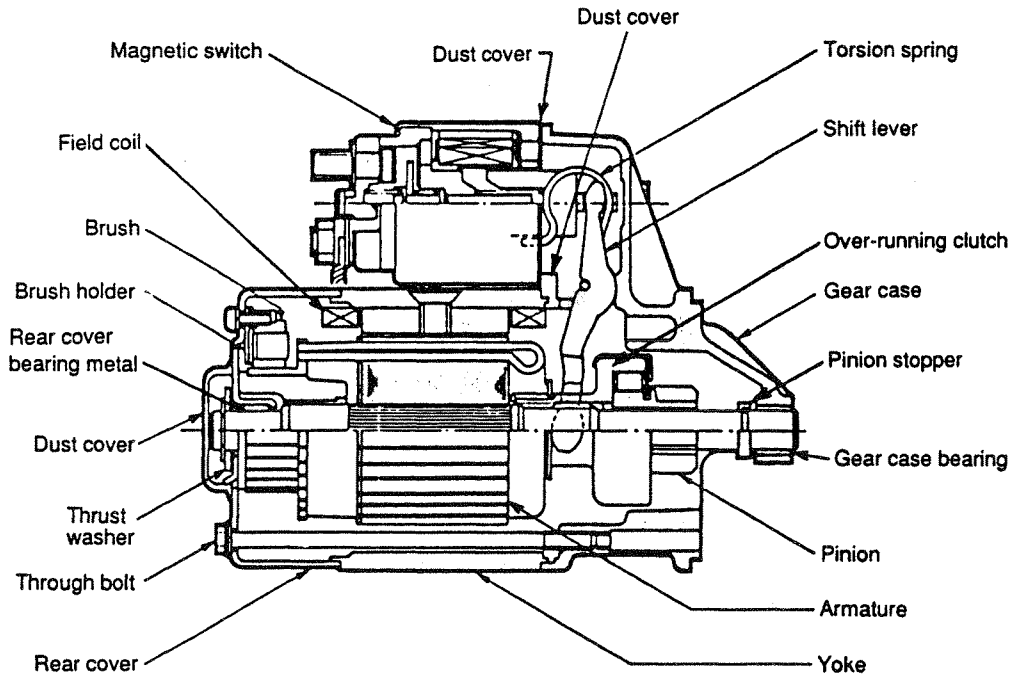

Over-running clutch

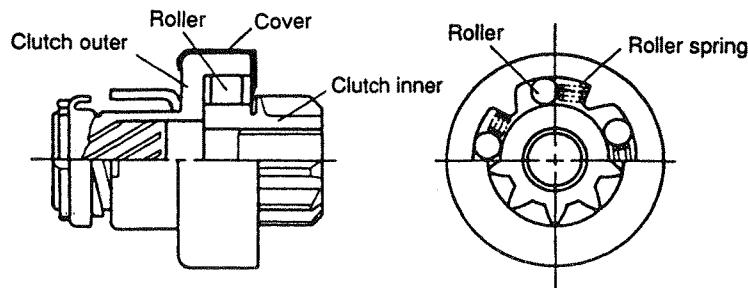

2.2 Reduction type startetr motor (Option for L75AE-SE – L100AE-SE)

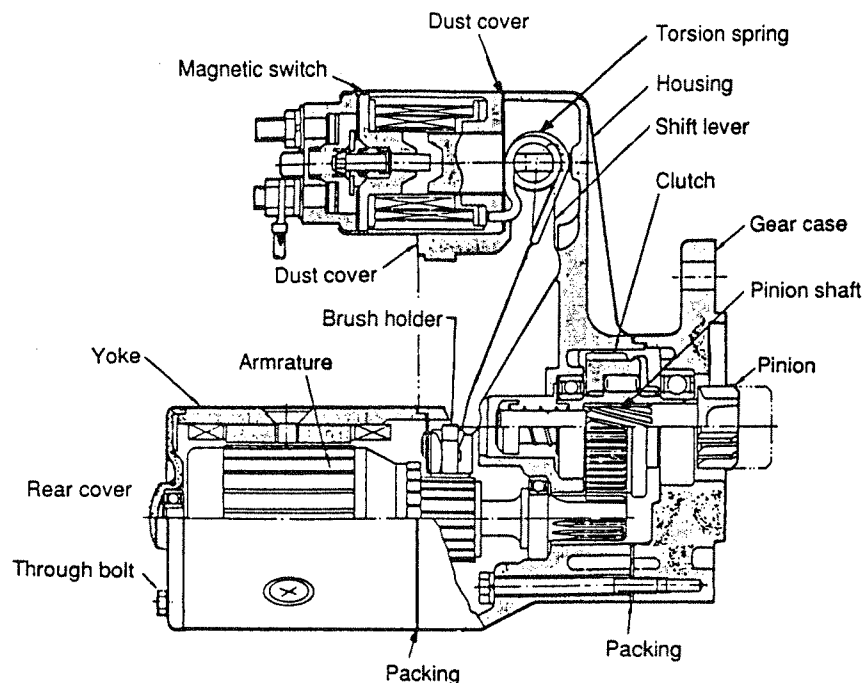

1) Construction of the reduction type starter motor

This motor is equipped with reduction gears between the armature and pinion; the reduction gears increase the torque of the motor before transmitting the torque to the pinion. The pinion and pinion shaft are shifted by the magnetic switch but the clutch assembly remains unmoved.

(1) Circumscribed type

The armature shaft is equipped with a small gear at the end, which is constantly engaged with a large gear on the circumference of the clutch. Thus, the revolution of the armature is transmitted to the pinion through the reduction gears and the clutch assembly. While the engine is being cranked, the motor emits a slightly loud sound because of the built-in reduction gears. This does not mean, of course, a sign of trouble.

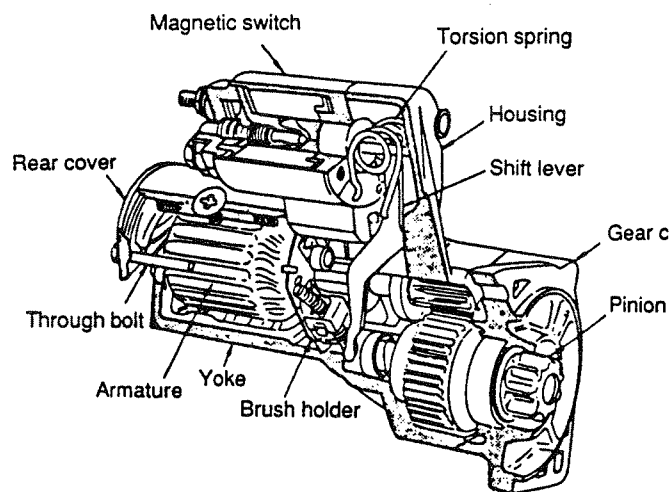

(2) Internal structure of reduction type

Illustration above shows the internal structure of the reduction type starting motor. This motor is similar to the magnetic shift type motor, except that it has a built-in reduction mechanism as its name implies.

In general type of starting motor, the armature is designed to turn at the same rpm as the pinion. However, the reduc-

tion type motor has its internal resistance reduced to about 25 – 33% of the conventional motor to a high-speed low torque motor while being a high torque motor by use of reduction gears.

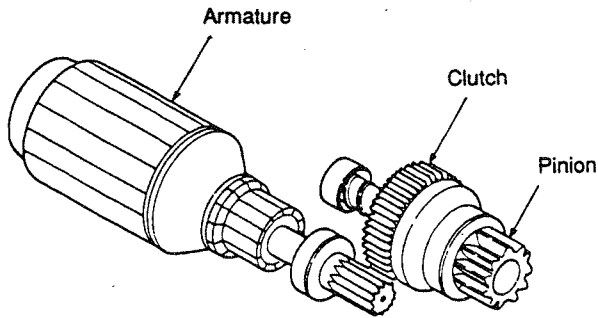

To prevent the motor from being affected by a shock when the engine starts and over-runs, the starter motor has an over-running clutch.

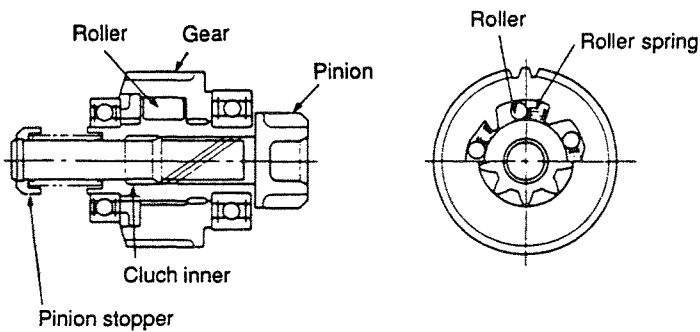

Over-running clutch

2) Operation

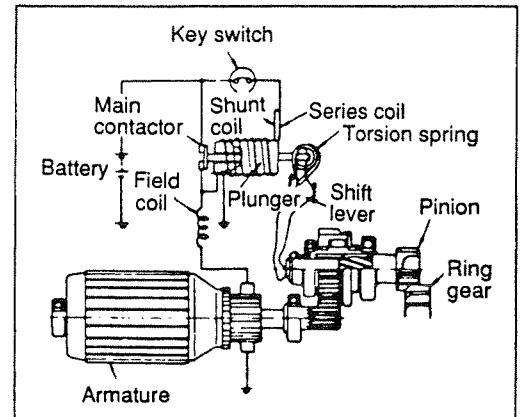
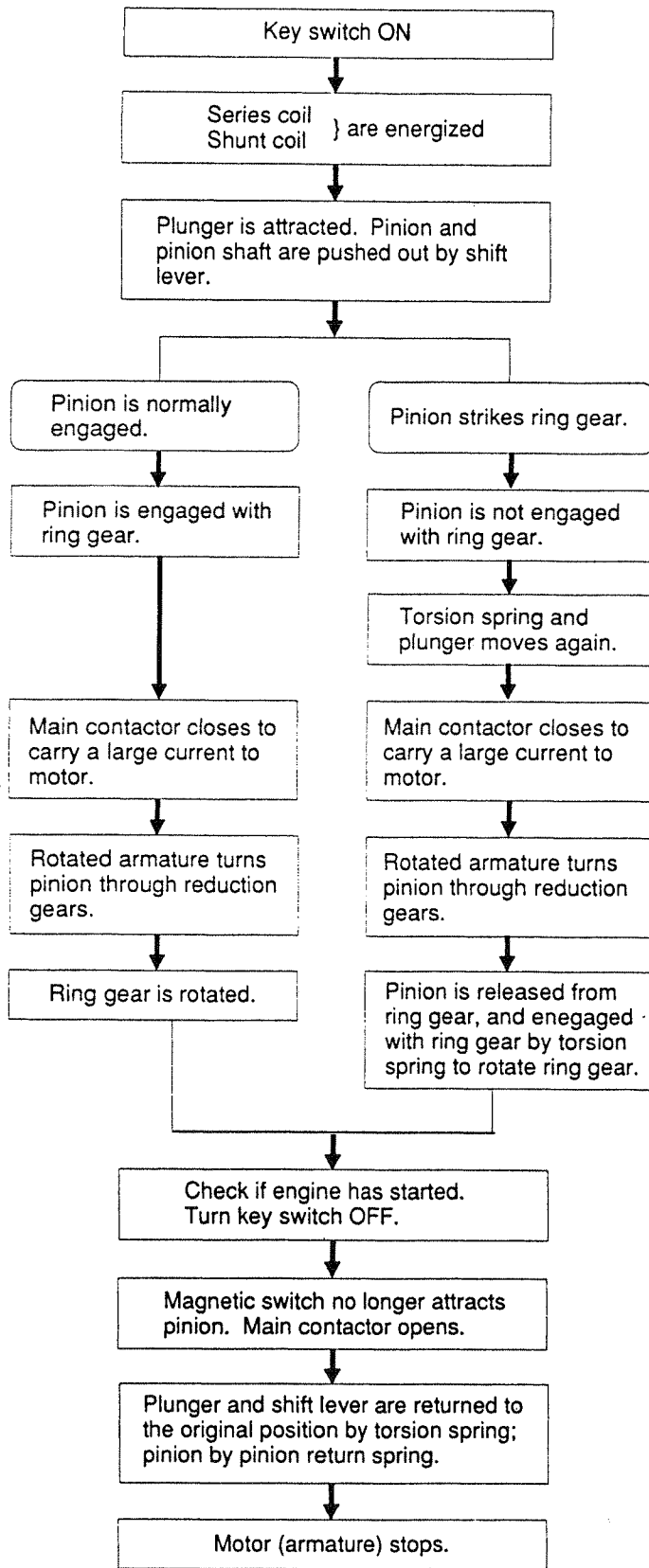

Pinion is engaged with ring gear

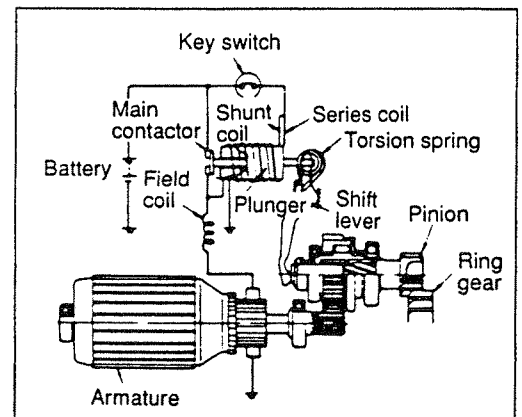

Ring gear is rotated

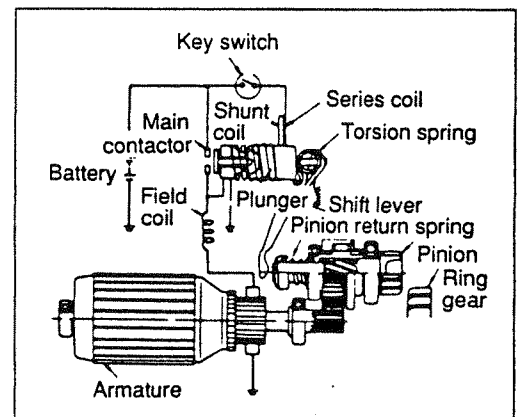

Key switch is turned off

3. Disassembly

3-1 Conventional starter motor (Standard)

1) Magnetic switch

- (1) Disconnect the magnetic switch wiring.
- (2) Remove the magnetic switch mounting bolt.
- (3) Remove the magnetic switch.
- (4) Separate the switch shift lever
- (5) Remove the torsion spring (for Reduction type Starter Motor only). Pull out the torsion spring on the magnetic switch.

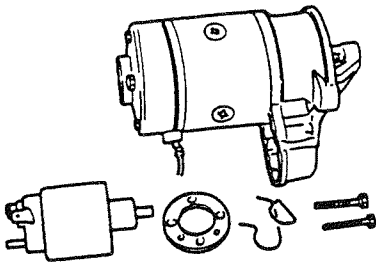
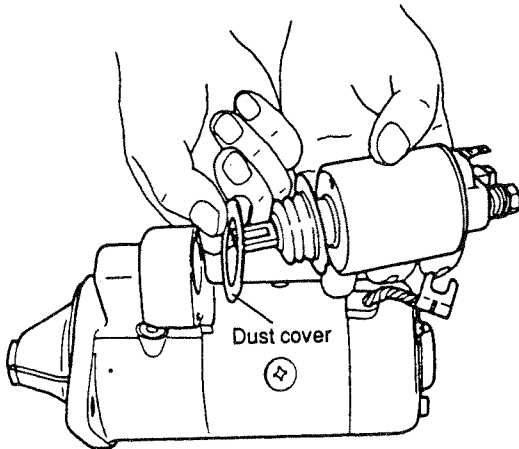

- Check whether the dust cover is kept. It is prone to be lost.

2) Rear cover

- (1) Remove dust cover.
- (2) Remove E-ring, and remove the thrust washer. Be careful not to lose the washer and shim.
- (3) Remove the two through bolts holding the rear cover and the two screws holding the brush holder.

- (4) Remove the rear cover.

- Make sure that the washer and shim are free from damage.
- Carefully keep the washer and shim until they are reassembled.

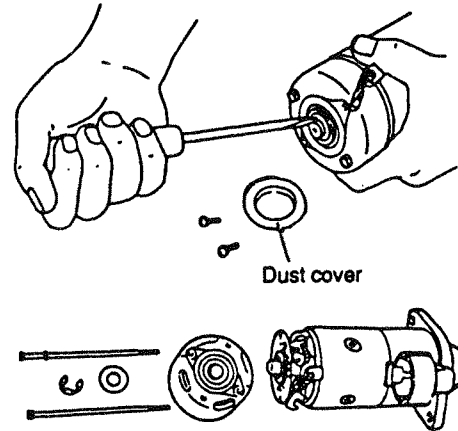

3) Brush holder

- (1) Lift the (-) brush from the commutator.
- (2) Remove the (+) brush from the brush holder.
- (3) Remove the brush holder
 - Number of brushes
 - (+) brush: 2
 - (-) brush: 1

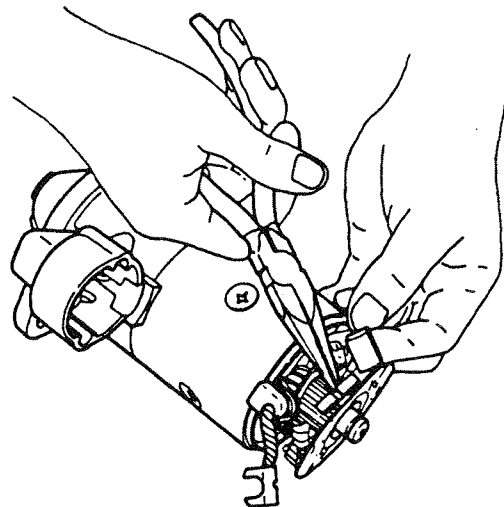

(Reduction type)

- (1) Removing yoke, armature, and brush holder. Pull out the yoke, armature, and brush holder simultaneously. Gently pull out the brush and commutator, avoiding interference with the

surrounding section.

4) Yoke

- (1) Extract the yoke from the armature.
 - Pull it out slowly so that it does not strike against other parts.

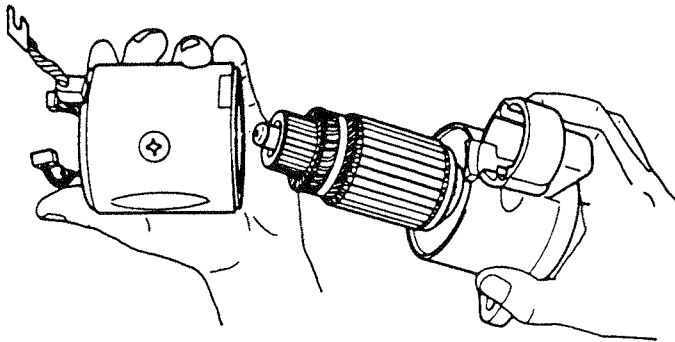

5) Armature

- (1) Remove the armature from the gear case.

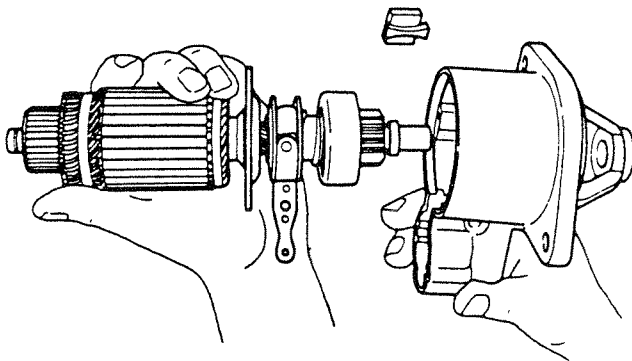

6) Pinion

- (1) Slide the pinion stopper to the pinion side.
- (2) Remove the pinion stopper clip using a screwdriver.
- (3) Remove the pinion from the armature.

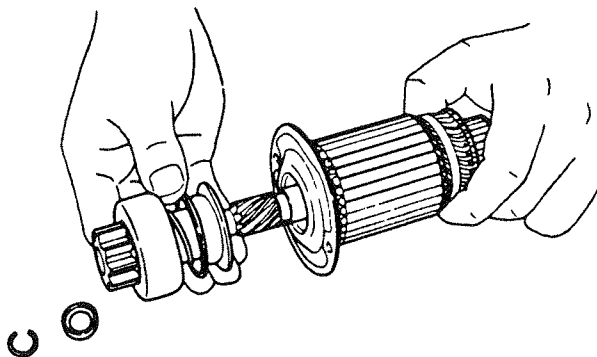

3-2 Reduction type (Option)

1) Wiring, Rear cover, yoke and armature

- (1) Disconnect the magnetic switch wiring.
- (2) Remove the two through bolts.
- (3) Remove the rear cover, yoke and armature.

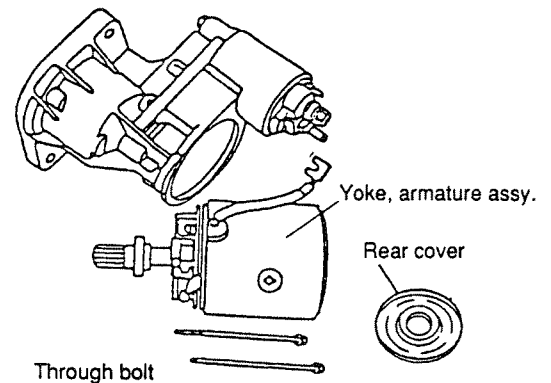

2) Brush, armature and yoke assy.

- (1) Lift the brush spring using the brush spring lifter. Touch the brush spring to the side of the (-) brush and float the brush from the commutator.
- (2) Remove the (+) brush from the brush holder.
 - Brush: (+) and (-) brush each 2 pcs.

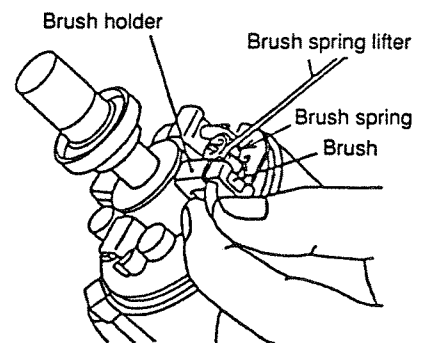

- (3) Remove the brush holder.
- (4) Remove the armature and yoke assembly.

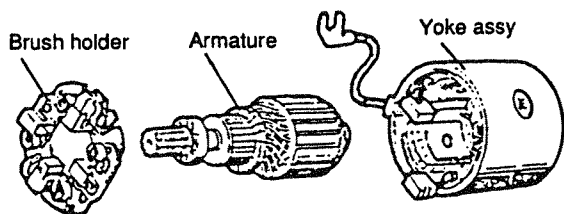

3) Magnetic switch

- (1) Remove the magnetic switch mounting bolts.
- (2) Remove the magnetic switch.
- (3) Separate the torsion spring from the magnetic switch.

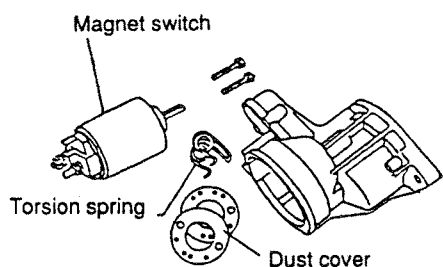

4) Dust cover and shift lever

- (1) Separate the dust cover and shift lever.

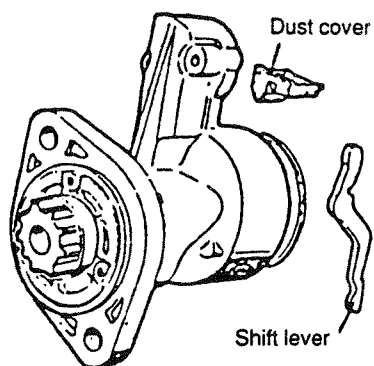

5) Clutch assembly (with pinion shaft)

- (1) Remove the gear case/housing mounting screws.
- (2) Remove the clutch assembly (w/pinion shaft) from the gear case.

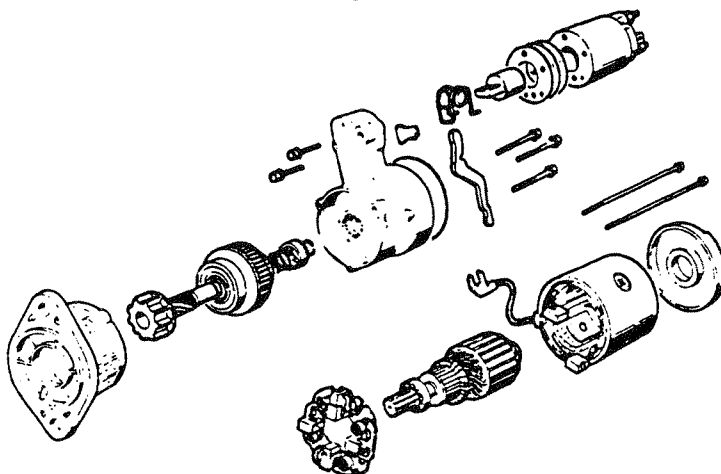

6) Clutch disassembly

- (1) Move the pinion stopper toward the pinion and remove the pinion stopper clip with a minus screwdriver.

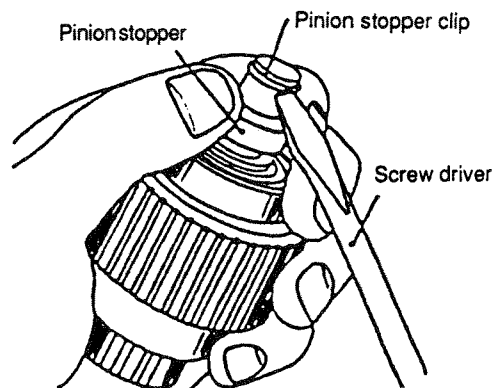

- (2) Remove the pinion stopper and return spring, and the pinion shaft from the clutch assembly.

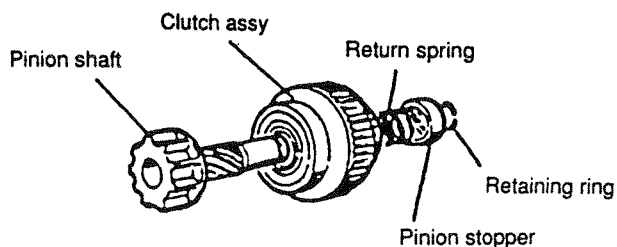

4. Inspection

Check the reduction type starter motor in the same way as the conventional type.

1) Armature

(1) Armature coil ground test

Use a circuit tester to check for the insulation between the commutator piece and the shaft (or armature core).

If an insulation failure is detected, replace the armature.

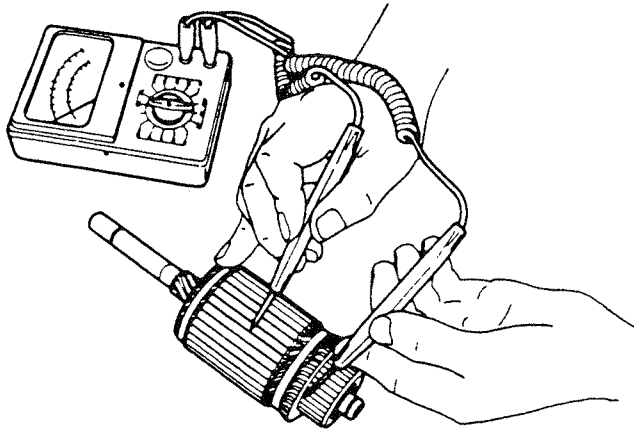

a) Armature coil shortcircuit test

Place the iron piece (a saw-like one) on the armature fitted to the layer short tester and turn the armature by hand. If the iron piece vibrates, it implies a short circuit and the armature should be replaced.

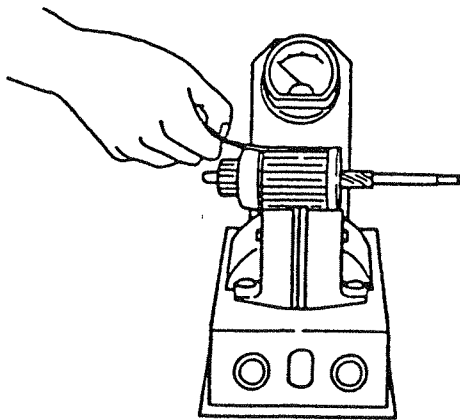

b) Commutator

Inspect the surface of the commutator. If it is corroded or pitted, grind with #500 ~ #600 sandpaper. Replace the commutator if damage is irreparable.

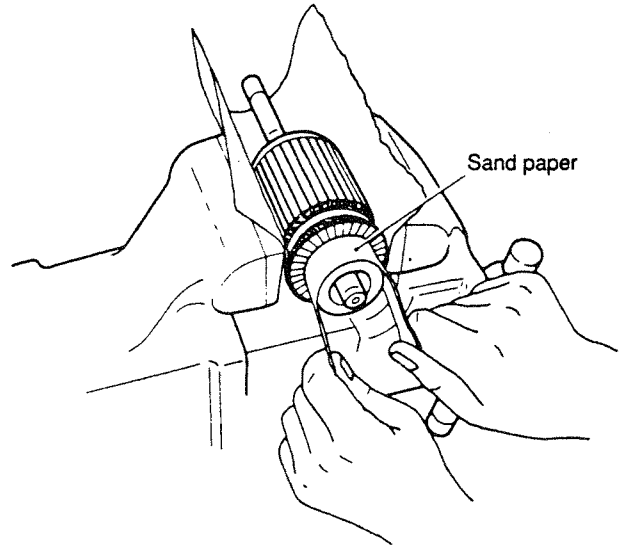

	Maintenance standard	Wear limit
Commutator outside diameter	<i>See separate service data (P.83).</i>	
Commutator run-out		

c) Armature shaft outside diameter

Measure the outside diameter of the armature shaft at four locations: front, center, end, and pinion. Replace the armature if the shaft is excessively worn.

Check the bend of the shaft; replace the armature if the bend exceeds 0.08 mm (0.0031 in.)

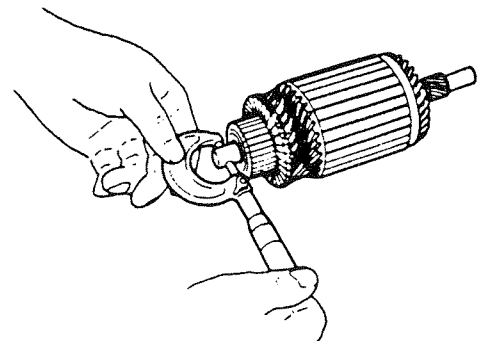

(2) Depth of commutator insulating material

Check the insulating material for depth. The depth is within a range from 0.5 to 0.8 mm, the commutator is acceptable. Correct with a hacksaw blade when the under cut is too shallow (0.2 mm tolerable limit)

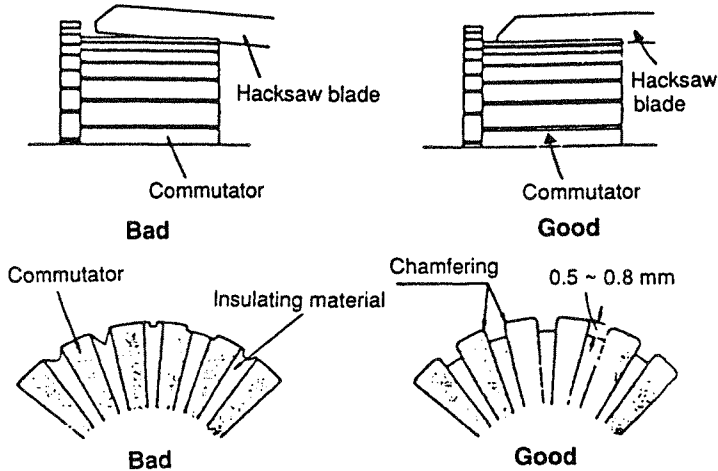
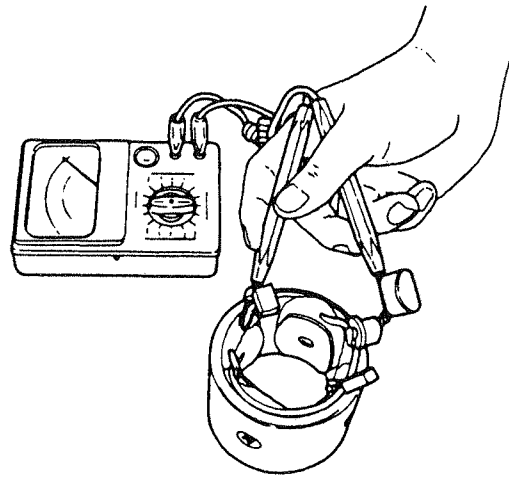

(2) Short-circuit test

Check the continuity between the yoke and any field coil terminal. Continuity indicates that the coil is shorted and it must be replaced.

(3) Cleaning the inside of the yoke

If any carbon powder or rust has been deposited in the yoke, blow the yoke out with dry compressed air.

* Do not remove the field coil from the yoke.

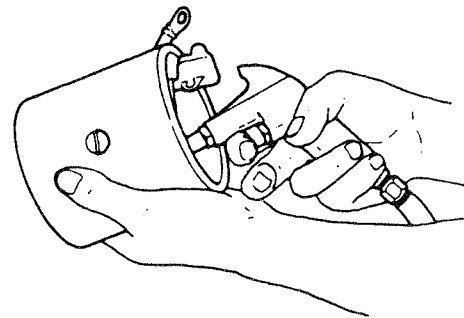

	mm (in.)	
	Maintenance standard	Repair limit
Insulating material	<i>See separate service data (P.83).</i>	

2) Field coil

(1) Open test

Check the field coil for disconnection and grounding.

Check the continuity between the terminals connecting the field coil brushes. Continuity indicates the coil is opened. If not, replace the coil.

3) Magnetic switch

(1) Shunt coil continuity test

Check the continuity between the C terminal and the magnetic switch body (metal part). If discontinuity is detected replace the magnetic switch, whose shunt coil is disconnected.

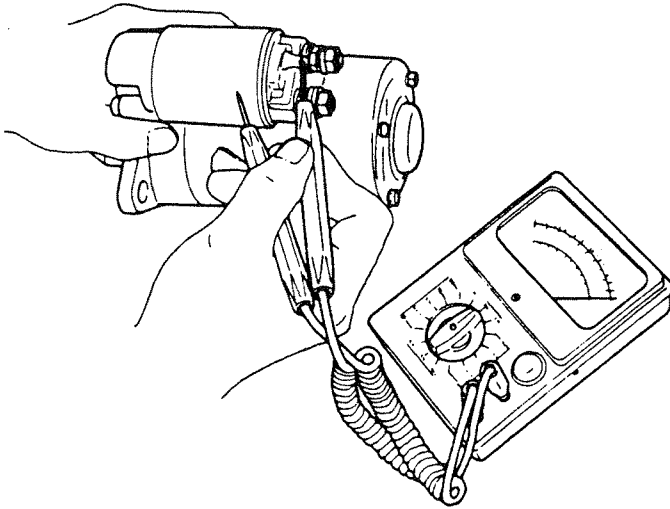

Coil resistance (at 20°C)	1.13Ω (Reduction type: 0.6Ω)
---------------------------	---------------------------------

(2) Series coil continuity test

Check the continuity between the terminal C and M of the magnetic switch is detected.

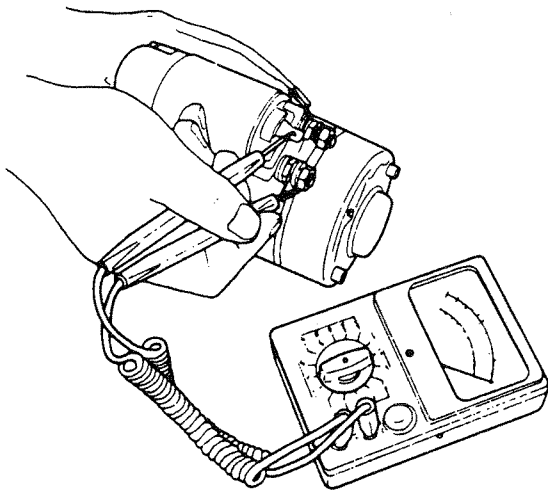

Coil resistance (at 20°C)	0.33Ω
---------------------------	-------

(3) Contact test of contactor

Push the plunger with your finger and check the continuity between the M terminal and B terminal. If discontinuity, the

contact is faulty and that the contactor must be replaced.

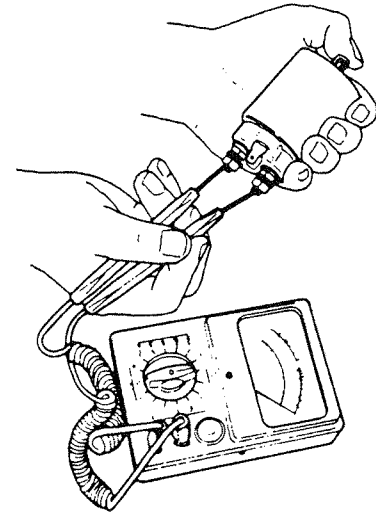

4) Pinion

- (1) Inspect the pinion teeth and replace the pinion if the teeth is excessively worn or damaged.
- (2) Check if the pinion slides smoothly; replace the pinion if faulty
- (3) Inspect the springs and replace if faulty.
- (4) Replace the clutch if it slips or seizes.

5) Brush

The brushes are quickly worn down by the motor. When the brushes are defective, the output of the motor will drop.

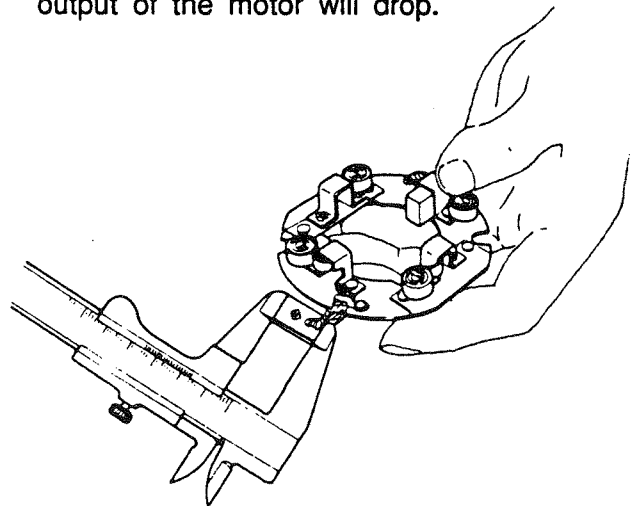

(1) Brush dimensions

Replace brushes which have been worn beyond the specified wear limit.

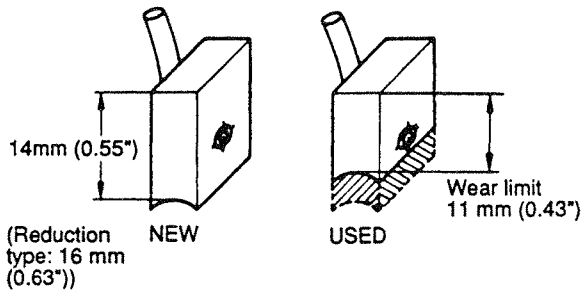

(2) Brush appearance and movement in brush holder

If the outside of the brush is damaged, replace it. If the movement of the brushes in the brush holder is hampered because the holder is rusted, repair or replace the holder.

(3) Brush spring

Since the brush spring pushes the brush against the commutator while the motor is running, a weak or defective spring will cause excessive brush wear, resulting in sparking between the brush and the commutator during operation. Measure the spring force with a spring balance; replace the spring when the difference between the standard value and the measured value exceeds $\pm 0.2\text{kg}$.

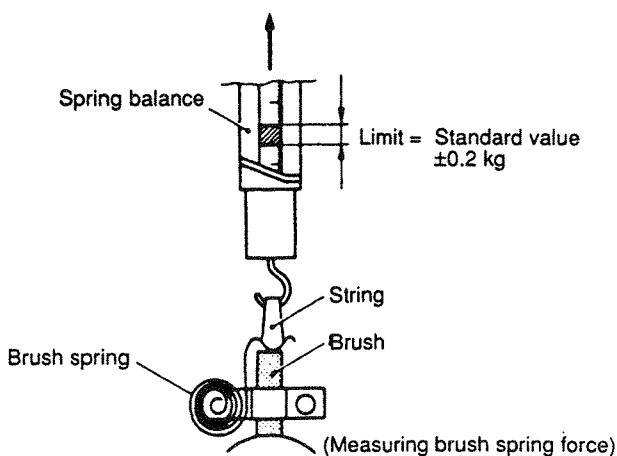

Standard spring load	2.0 kg
----------------------	--------

CAUTION:

Whenever overhauling the motor or removing the brush, apply high quality grease to the specified greasing point. This extends the service life of the bearing on the brush side, although the bearing uses an oilless alloy.

(4) Brush holder ground test

Check the continuity between the insulated brush holder (+) and the base (-) grounding) of the brush holder assembly. Continuity indicates that these two points are grounded and that the holder must be replaced.

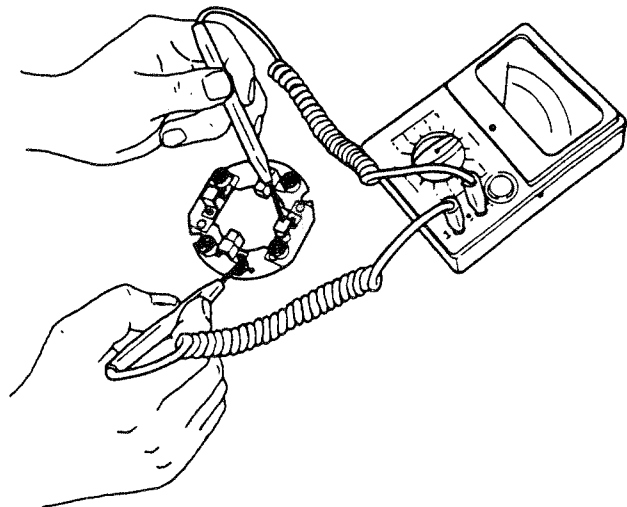

5. Adjustment and Performance test

1) l -size measurement (gap between pinion and pinion stopper)

[Conventional starter motor]

When the pinion is at the projected position, measure the gap between pinion and pinion stopper. This measurement should be made with the pinion pressed back lightly to take up any play in engagement linkage.

l dimension
0.3 - 2.5 (0.012 - 0.098)

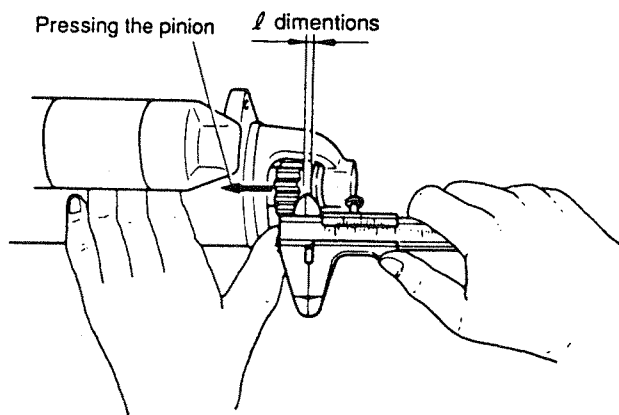

Measuring of l dimension

[Reduction type]

Connect the wiring as shown in the sketch below. Turn on the switch and measure the ' l ' distance in the pinion thrust direction.

l dimension
0.3 - 1.5 (0.012 - 0.059)

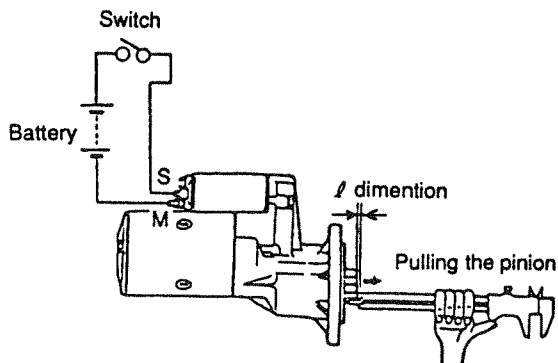

Measuring of l dimension

2) Pinion movement

To measure the l dimension, connect the \oplus wire of the battery to the S terminal, and the \ominus wire to the starter motor. When attracting the plunger and pushing out the pinion with the shift lever, push (or draw) the pinion by finger in the arrow direction. Make sure the pinion does not chatter before, the measurement.

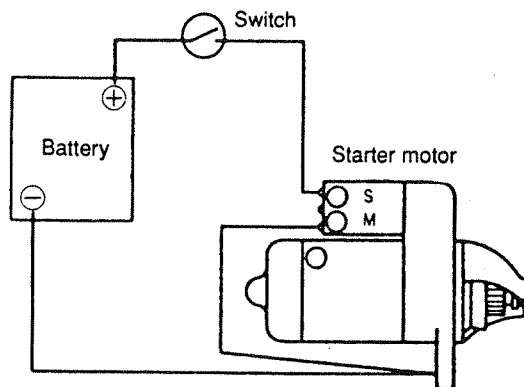

3) Plunger movement (Applicable also to the reduction type)

Adjustment the stroke of magnetic plunger to the prescribed value. Adjust the l dimension installing shim (adjusting plate) on the magnetic switch board.

There are two types of shim: 0.5 mm (0.0197 in.) and 0.8 mm (0.0315 in.) in thickness.

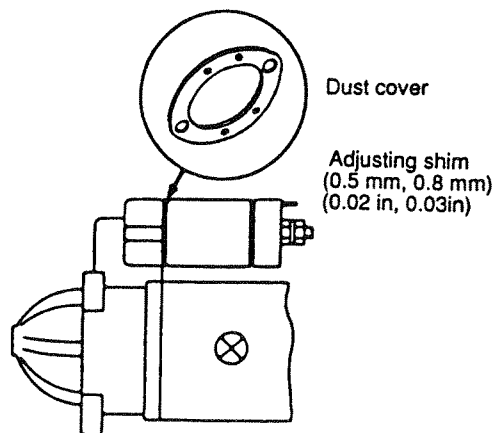

4) Mesh clearance (Applicable also to the reduction type)

Mesh clearance is the distance between the flywheel ring gear and starter motor pinion in the rest position. This clearance must be 3 mm (0.1181 in.) to 5 mm (0.1969 in.).

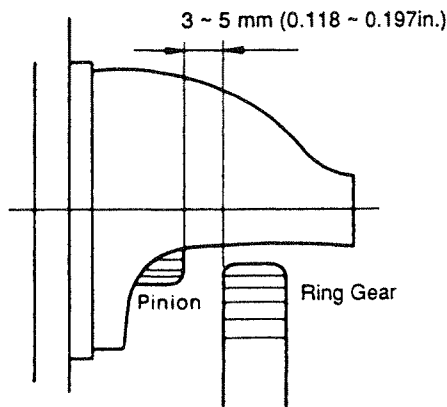

(3) Mounting the magnetic switch

Attach the magnetic switch and shift lever assembly to the gear case. Fix the magnetic switch with M6 lock bolts.

Be sure to install the dust cover before assembling the gear case (Tightning torque: 65 – 80 kg-cm (4.71 – 5.80 lb-ft)). After reassembly, check by conducting no-load operation.

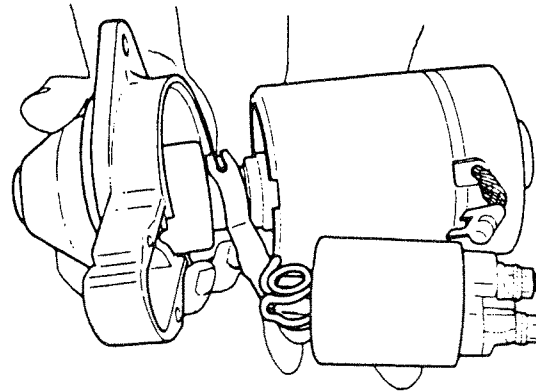

6. Reassembly precautions

When reassembling the starter motor in the reverse order of disassembly, paying a special attention to the following points:

(1) Where to grease

- Gears in the gear case
- Operating part of the shift lever
- Sliding part of the pinion
- Plunger sliding part of the magnetic switch

(2) Torsion spring and shift lever

Hook the torsion spring into the hole in the magnetic switch and insert the shift lever into the notch in the plunger of the magnetic switch (through the torsion spring).

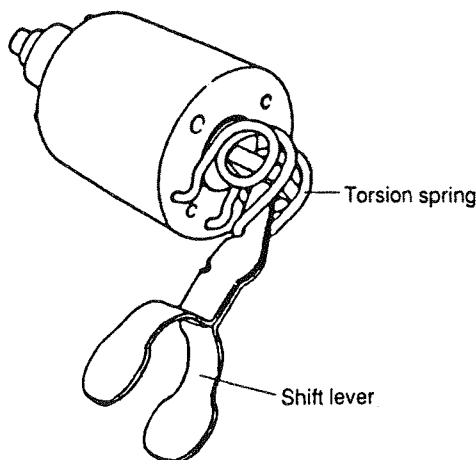

7. Characteristics test

The some characteristics can be checked easily by the no-load test procedure described below.

- The test should be carried out immediately because the rating of the starter motor is 30 seconds.

1) No-load test

Fix a starter motor on a test bench. Connect wiring to the motor as illustrated. Close the switch, and current flows through the motor, which is rotated at no-load. Measure working current, voltage, and motor revolutions. Check whether the specified characteristics are satisfied.

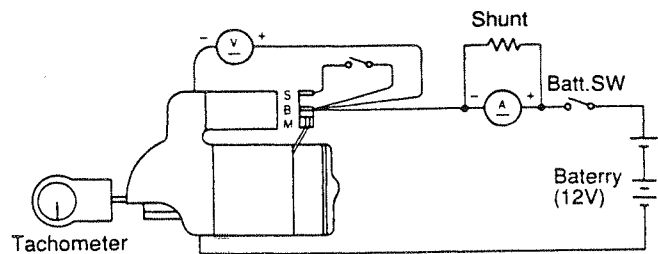

8. Maintenance Standards

Measuring position/item		Unit	S114-413A, 414A	S114-478	
Brush	Standard spring load	kg (lb)	1.8-2.2 (3.77-4.85)		
	Standard height	mm (in.)	14 (0.551)	16 (0.630)	
	Wear limit	mm (in.)	11 (0.433)		
Magnetic switch	Series coil resistance	Ω	0.33		
	Shunt coil resistance	Ω	1.13	0.6	
Commutator	Outside diameter	Standard	mm (in.)	33 (1.299)	30 (1.181)
		Wear limit	mm (in.)	32 (1.260)	29 (1.142)
	Off-set	Standard	mm (in.)	0.05 (0.002)	0.03 (0.0012)
		Repair limit	mm (in.)	0.4 (0.015)	0.2 (0.008)
	Mica depth	Standard	mm (in.)	0.5-0.8 (0.02-0.03)	
		Repair limit	mm (in.)	0.2 (0.008)	
Standard dimension	Brush side bearing	Shaft diameter	mm (in.)	12.450-12.468 (0.490-0.491)	—
		Bearing inside diameter	mm (in.)	12.500-12.518 (0.492-0.493)	—
	Pinion sliding section	Shaft diameter	mm (in.)	12.450-12.468 (0.490-0.491)	—
		Pinion inside diameter	mm (in.)	12.53-12.55 (0.493-0.494)	—
	Pinion side bearing	Shaft diameter	mm (in.)	12.450-12.468 (0.490-0.491)	—
		Bearing inside diameter	mm (in.)	12.500-12.518 (0.492-0.493)	—
	Clutch bearing	Front (Pinion side)	—	—	6004DDU
		Rear	—	—	6904ZZ
	Armature bearing	Front (Pinion side)	—	—	6903Z
		Rear	—	—	608Z

3. Generator (Dynamo), Regulator and Rectifier

The standard dynamo for the L-A type engine manufactured to the electric starting specification is rated at 12 V and 3A. Optionally available are dynamos of the 12 V system, which are rated at 1A, 1.7A and 15A. Also available are dynamos

rated at 12V-35W, 12V-40W, 6V-15W, which are used exclusively for lighting of engines to the recoil, S specification.

- Recoil specification: L40AE – L70AE

1. Specifications

Model		GP9585	GP9589	GP9587	GP9595"	GP9591
Type		Magnet system	←	←	←	←
Combination	Regulator	(1)	—	RS5112 (2)	RS5112 (3)	—
	Rectifier	ZR2117 (Half wave)	ZR2120 (Full wave)	—	—	—
Output at 3600 rpm (V/A) (20°C)	DC	13/1.0 – 1.3	13/1.6 – 1.8	13/2.6 – 3.3	12/14.8 – 16	—
	AC voltage (4)	—	13V/25W lamp- 12.5~15V	13V/40W	—	6V/15W lamp -7±0.5V
Direction of rotation		Clockwise or counterclockwise	←	←	←	←
At charging start (rpm)		≤ 1500/at 13 V	—	—	≤1000/at 12 V	—
Regulated voltage on regulator		—	—	14.5±0.5V	←	—
Permissible ambient temp. (°C)		-20 – +65	←	←	←	←
Color	Covered wire (2-wrie)	Green/White and Green/White	←	←	←	Red and Black
	Tube	Black	Gray	Black	Yellow	Yellow
Remark		for electric starting	for electric starting or for lighting of engines to the recoil, S-spec.	for electric starting (standard) or for lighting of engines to the recoil, S-spec.	for electric starting	only for lighting of engines to the recoil, S-spec.

Notes:

The dynamo may be combined with:-

- (1) RS5133 type regulator (with a built-in safety relay drive circuit).
- (2) RS2190 type regulator (without the charge lamp circuit), or
- (3) RS5110 type regulator (with a built-in safety relay drive circuit), and
- (4) The dynamo used only for lighting of engines to the recoil, S-spec. is equipped with neither a regulator nor rectifier, and outputs AC voltage.

2. Construction

The dinamo is composed of the starter coil and rotor; the stator is bolted to the cylinder block, and the rotor to the flywheel.

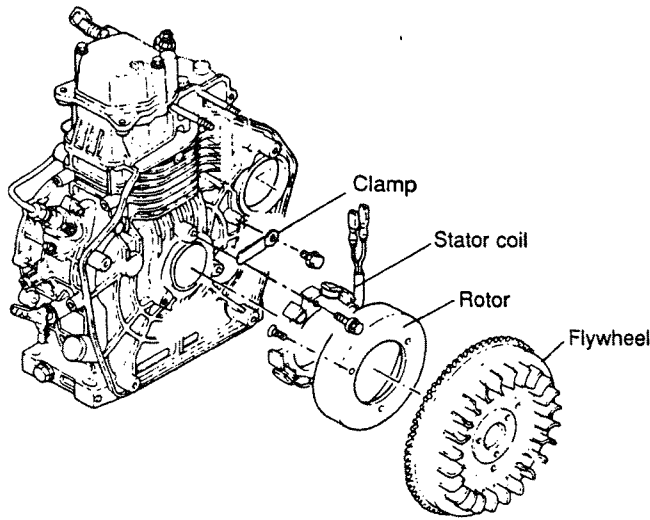

3. Generator check

Follow the directions to check whether the generator works normally.

- (1) Disconnect the generator output from the regulator, with the generator left coupled with the engine.
- (2) Connect the generator output to a volt/ammeter.
- (3) Set the volt/ammeter to the 100 VAC range.
- (4) Start the engine and check the volt/ammeter.
- (5) When the volt/ammeter reads the specified value, the generator is in normal operation. (Measure voltage between the connectors.)

Voltage (VAC)

	GP9585	GP9589	GP9587	GP9595	If the voltage is too low or 0V, the magnet is demagnetized or disconnected.
3750 rpm	Approx. 35.7	Approx. 53.8	Approx. 45.4	Approx. 41.5	
3200 rpm	Approx. 30.3	Approx. 46	Approx. 39	Approx. 35.5	

① Stator coil continuity test

Disconnect the green/white wire to the dynamo or red and black connectors. Check the stator coil for continuity using a circuit tester. If continuity is not detected ($\infty\Omega$), replace the stator coil, which is disconnected

⚠ Note

When the megger is used, short the circuit within 1 or less second.

② Coil insulation test

Remove the green and white, or red and black conductors from the dynamo.

1. Connect a cable from the megger (or circuit tester) to the G/W wire or red connector.
2. Connect the other cable from the megger (or circuit tester) to the cylinder block for 1 or less second, and check the indicator

of the megger (or circuit tester).

If there is continuity (the resistance is zero), replace the stator coil.

Tester's reading	Continuity	Evaluation	
∞	NO	Normal	—
0Ω	YES	Abnormal	Replace the stator coil

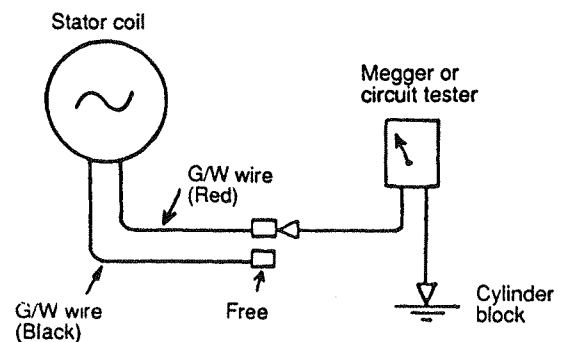

③ Inspection of dynamo /regulator (combination)

To inspect the dynamo/regulator, connect a voltmeter and ammeter to the dynamo/regulator circuit, as illustrated below.

Use a battery capable of running the engine.

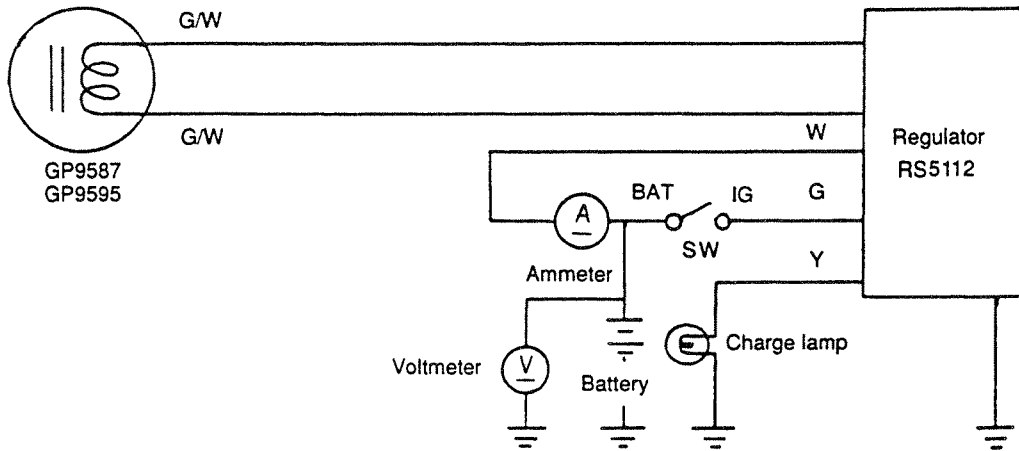

Relationship between charge current and battery terminal voltage (at 3600rpm)

	Evaluation	Cause
14V or less 2A or more (GP9587) 13.5 A or more (GP9595)	Normal	—
14 ~ 15V (within a range of voltages regulated by the regulator) 2~0.2A (GP9587) 13.5 ~ 0.3A (GP9595)	Normal	—
15V or more (reference) 2A or more (GP9587) 13.5A or more (GP9595)	Abnormal	Replace the regulator, which is faulty.
15V or less; charge current 0A		The regulator or dynamo is faulty, or wires are improperly connected.
A charge current flows but the battery fails to attain a desired terminal voltage. (The battery is discharged.)		Replace the battery, which is faulty.

④ Inspection of discrete regulator
(simplified inspection)

Check the continuity between the terminals on a discrete regulator listed the table below. The continuity between the regulator case and each terminal must also be checked. The values in the table were obtained in the normal condition. Note that this simplified in-

spection is not intended to detect all failures and trouble in the regulator.

Notes:

1. Use a tester at a range of 1Ω.
ON: The pointer moves
OFF: The pointer does not move
2. Be sure to inspect a desired regulator while checking it against a normal one.

RS5112

Tester		Red lead wire (+)					
Tester	Terminal No.	1	2	3	4	5	6
	Terminal No.						
Black lead wire (-)	1		1 OFF	2 OFF	3 OFF	4 OFF	5 OFF
	2	6 ON		7 OFF	8 OFF	9 OFF	10 OFF
	3	11 ON	12 OFF		13 OFF	14 OFF	15 OFF
	4	16 OFF	17 OFF	18 OFF		19 OFF	20 OFF
	5	21 ON	22 ON	23 ON	24 OFF		25 ON
	Case	26 OFF	27 OFF	28 OFF	29 OFF	30 OFF	

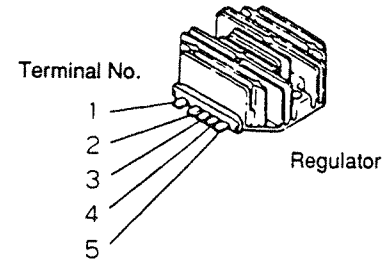

Symptom	Faulty point No.	Probable cause
The charge lamp does not turn off.	24: ON	The harness between the charge lamp and terminal No.4 of the regulator is likely to interfere with the body.
The fusible link is fused.	5: OFF, 26: ON	The battery is likely to be connected in reverse.
	5: ON, 26: ON	The regulator is likely to be poorly insulated within it or the battery is likely to be connected in reverse.
The battery is insufficiently charged or the charge lamp does not turn off.	6: OFF, 11: OFF	In the regulator the circuit is likely to be opened because of poor soldering.
The battery is insufficiently charged or the charge lamp turns off at higher revolutions of the engine.	6 or 11: OFF	In the regulator the circuit is likely to be opened because of poor soldering.
The battery is insufficiently charged or the charge lamp does not turn on.	10 or 15: ON	The battery is likely to be connected in reverse.

RS2190

Tester		Red lead wire (+)				
Tester	Terminal No.	1	2	3	4	5
	Terminal No.					
Black lead wire (-)	1		ON	ON	OFF	ON
	2	OFF		OFF	OFF	ON
	3	OFF	OFF		OFF	ON
	4	OFF	OFF	OFF		OFF
	5	OFF	OFF	OFF	OFF	

Note:

Terminal Nos. are the same as those listed above.

⑤ Inspection of rectifier

(1) ZR2117 (Half-wave rectifier)

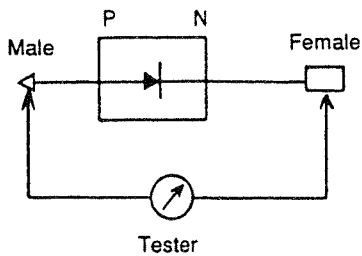

Terminal	Male	Female	Continuity (Normal)	
Tester	+ (Red)	- (Black)	No	Replace the rectifier if the left requirements are not met.
	- (Black)	+ (Red)	Yes	

(2) ZR2120 (Full- and half-wave rectifier)

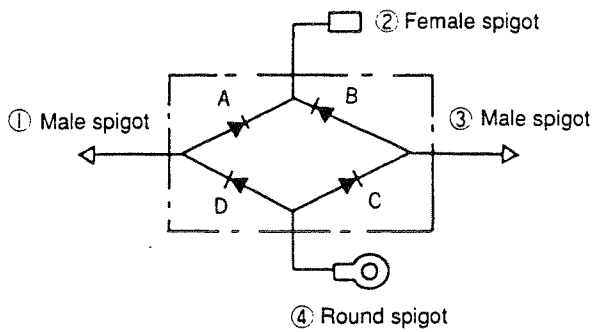

Terminal	Diode A		Diode B		Diode C		Diode D		Continuity (Normal)	
	①	②	②	③	③	④	④	①		
Tester	+	-	-	+	-	+	+	-	No	Replace the rectifier if the left requirements are not met.
	-	+	+	-	+	-	-	+	Yes	

4. Air Heater (Optional)

An air heater is available for warming intake air during starting in cold weather. The air heater is mounted on the end of the intake bend.

The device is operated by the key switch on the instrument panel.

A timer is used for the pre-heating. When the air heater key switch is turned on, the pilot lamp lights. The timer is set so that the pilot lamp goes off 15 sec. after the system is turned on. When the pilot lamp goes off, once turn the key switch off. Then, turn the key switch to the START position to start the engine.

An air heater system circuit consists of an air heater, pilot lamp and timer.

Air heater system circuit (without timer)

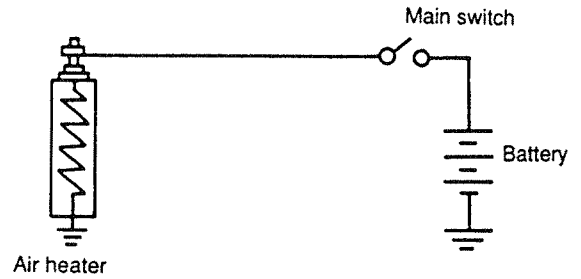

Air heater circuit (with timer)

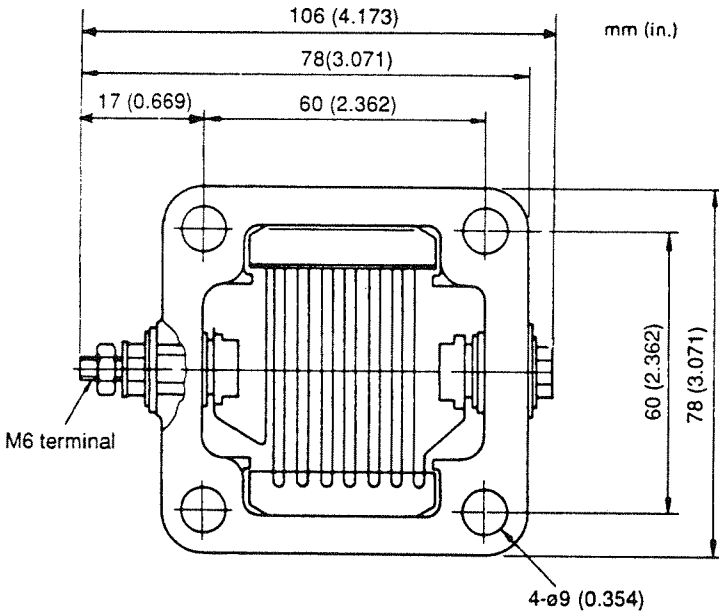
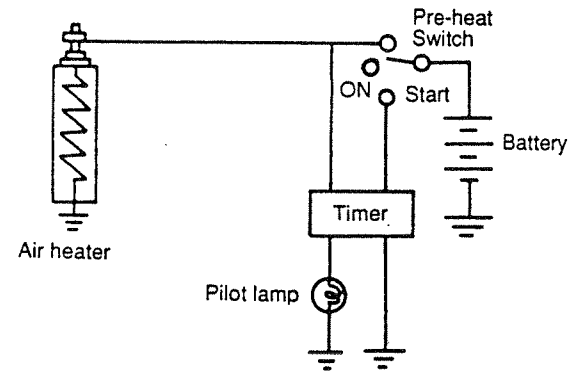

Rated output	400W
Rated current	33.3A
Rated voltage	DC 12V
Rated operating time	Pre-heating: 15 sec. Engine operation: 30 sec. max. Engine stop: 30 sec.
Range of operating temperature	-30°C (-22°F) or higher
Earth polarity	Negative earth/Body earth

5. Battery

The battery is used to start the engine (or to bear a lamp load) and must be well charged. Do not use a poorly charged battery which may be unable to attain the motor revolutions required to start the engine at low temperature.

1. Battery capacity and battery cables

1) Battery capacity

Recommended battery capacity (20 hrs rating) Ambient temperature

	18AH	24AH	30AH	35AH	40AH	45AH
L40AE/L48AE	-10°C (14°F) or higher		-30°C (-22°F) or higher			
L60AE/L70AE		-10°C (14°F) or higher		-30°C (-22°F) or higher		
L75AE ~ L100AE	—	—	—	-10°C (14°F) or higher		-30°C(-22°F) or higher

2) Battery cable

To connect the battery to the starter, thick and short wires must be used. (low-voltage cables for automobile [AV wire]).

Using wire other than that specified may cause the following troubles:

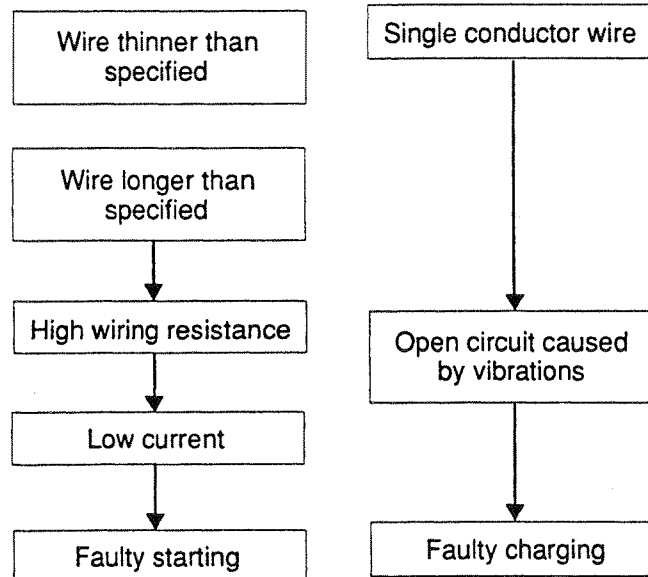

2. Battery inspection

- (1) Check the electrolyte level in each cell. If the level is insufficient, add distilled water to attain the upper limited level.

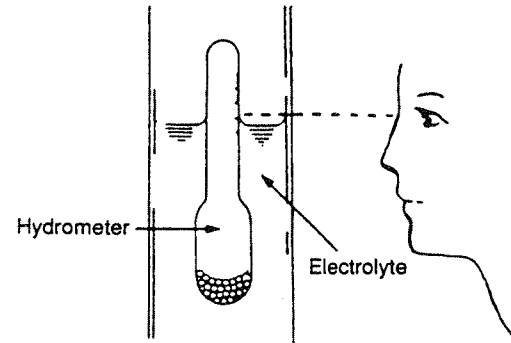
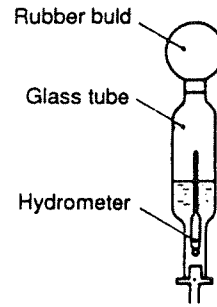
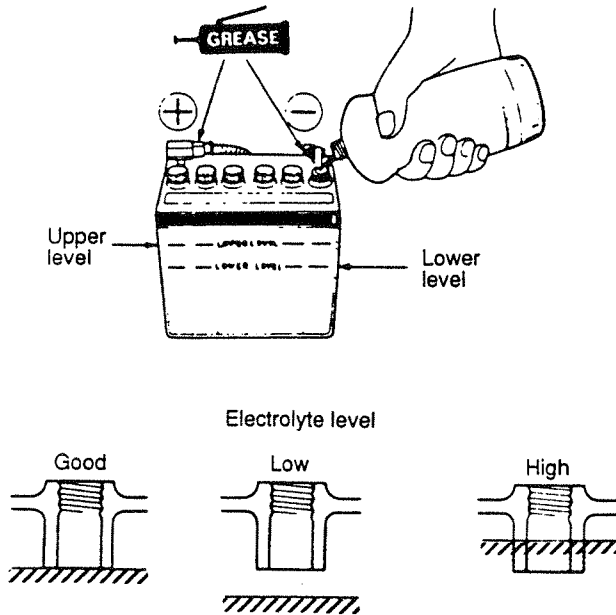

Check the electrolyte level every 7 to 10 days. The electrolyte must be kept 10 – 20 mm (0.3937 – 0.7874 in.) over the top of the plates.

- (2) Check the battery case for loose parts, cracks or flaws.
- (3) Check the battery terminals for looseness and rusting.
- (4) Check the battery cap for clogged vent holes.
- (5) Test each cell by drawing electrolyte into the hydrometer.

Specific Gravity: 1.27 – 1.29 (Type II)
 1.26 – 1.28 (Type I)

Variation of Specific Gravity with Temperature

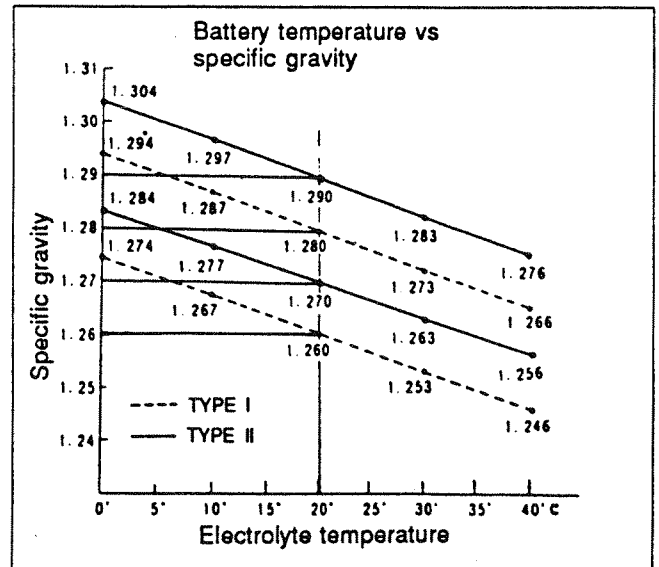

Note:

- Do not overfill the battery. Wipe up spilled electrolyte at once and flush well with water.
- The specific gravity varies with the temperature as shown in the accompanying table.
- The battery must be replaced if sulfation is evident.
- The battery must be replaced if there are pastes settled on the bottom of each cell.

WARNING

1. *Carfully protect yourself and your clothes against the battery electrolyte which is diluted sulfuric acid hard enough to injure the skin and eyes. If any injury is anticipated, consult the doctor at once.*
2. *When using the dynamos (combined with a regulator) on the engine, carefully check the battery for terminal voltage. If the terminal voltage is too low, the regulator works so that the dynamo fails to supply the voltage (about 6V or more) required to charge the battery. If so, use a battery charger.*

CAUTION:

Quick-charging should only be done in an emergency; slow-charging is preferred.

After installing the battery, coat the terminals with clean grease.

3. Battery charging

- 1) Remove the battery; remove the cap from each cell.
 - 2) Connect the charger positive (+) cable to the battery positive terminal.
 - 3) Connect the charger negative (-) cable to the battery negative terminal.
- Charging current:
Battery current 20 hrs. rating ~ 10 hrs. rating.

Example: 20 hrs. rating 45 AH, battery
 $(45 \div 20) - (45 \div 10) = 2.25A - 4.5A$

Charging:

Charging the battery until specific gravity is 1.270 – 1.290 at 20°C (68°F). (Incase of the battery of Type 1: 1.260 – 1.280)

WARNING

- *Before charging remove the cap from each cell.*
- *Keep fire and sparks from a charging battery.*
- *Turn power on/off at the charger, not at the battery terminals.*
- *Discontinue charging if the electrolyte temperature exceeds 45°C (113°F).*

4.13 ADJUSTMENT

1. Adjustment of fuel injection timing

Fuel injection timing must be precise. If it is too early or too late, a host of trouble will result in: difficulty in starting, knocking, lowered output, poor exhaust color, etc. Correctly adjust the governor linkage assembly and the injection pressure before adjusting the injection timing. When the engine is used for long periods of time, the injection pump plunger wears out and distorts the timing.

If the plunger is worn, replace it and read-just the injection timing.

1) How to check the injection timing.

- Set the speed control handle to "Run".
- Remove the fuel injection pipe, and install the injection timing measurement pipe.
- Match the TD position mark on the flywheel with the V notch line on the cylinder body fin.
- Turn the flywheel first clockwise then counterclockwise about 30° from the TD mark to make sure fuel is injected. (If it is not, turn the flywheel once).
- Turn the flywheel slowly until fuel flows out of the pipe. When the fuel begins to flow, check the angle using the mark on the flywheel.
- Repeat three or four times to make sure the reading is correct.

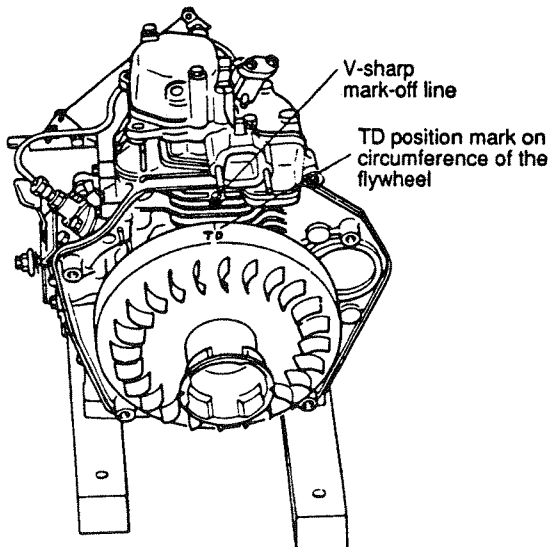

(TD position mark)

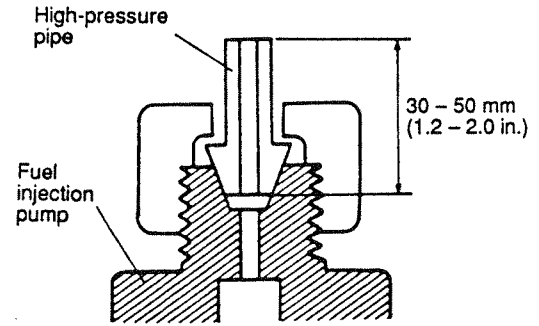

(Measurement pipe)

2) How to adjust the injection timing

- Remove the fuel injection pump and base.
- Add or remove adjusting shims.
If the timing is fast, add shims.
If the timing is slow, remove shims.
Each 0.1 mm (0.0039 in.) changes the timing by 1 degree (FID).

	L40AE-L70AE	L75AE-L100AE
Injection timing (FID bTDC) deg.	13-15	12-14

2. Bleeding air from fuel system

Air can enter the fuel oil pipe system when the engine is first installed, the fuel oil pipe is removed, etc. Bleed the air according to the following instructions:

- 1) Place the speed control handle in the run position.
- 2) Open all cocks of the fuel system.
- 3) Set the decompression lever to the position Non-compression.
- 4) Make sure that fuel comes out from the fuel injection nozzle while pulling the recoil starter, it can be heard injection sound. Loosen the delivery valve holder to bleed the air easily. Retighten it to 300 - 350 kg-cm (21.7 - 25.3 lb-ft) with a torque wrench.

3. Fuel injection volume limitation

1) Adjustment before shipment. The control lever is fixed after the rated revolutions and injection quantity have been checked with the pump installed on the special-purpose pump drive table. Then, a mark-off line is marked

on the spring sheet to line up with the edge of the control lever.

The access hole has an access hole pointer match mark. Make sure the mark-off line matches the edge of the control lever.

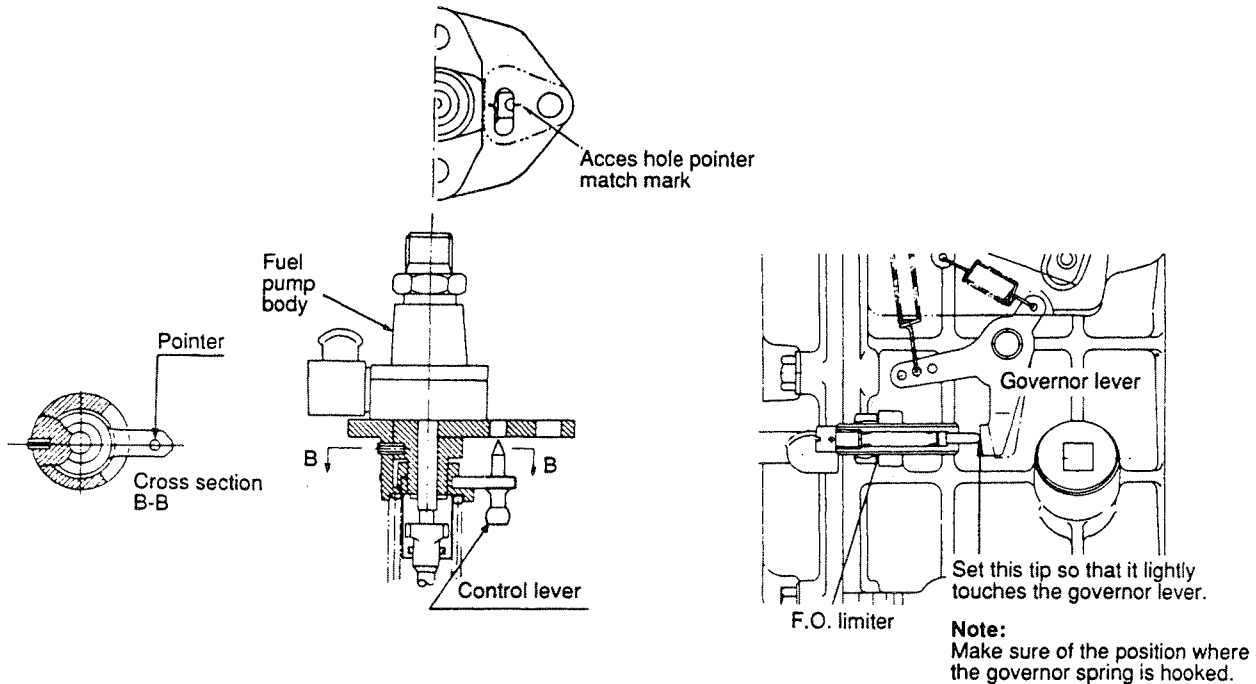

(Fuel injection volume limitation adjustment)

4. Adjusting the clearance on intake/exhaust valve head

Check the clearance at the disassembly and reassembly, and every 500 hours of operation. Then adjust it if necessary.

Intake/exhaust valve head clearance mm(in.)	0.10 – 0.15 (0.0039 – 0.0059) (cold state)
--	--

1) Adjustment

Adjust the clearance with a thickness gauge.

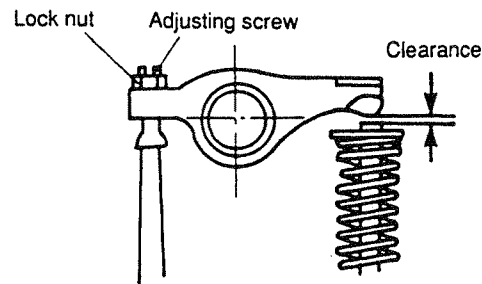

Clearance: 0.10 -0.15 mm (cold state)
(0.0039-0.0059in.)

(Adjusting the valve head clearance)

CAUTION:

Make sure each cylinder is in the T.D.C before adjusting the clearance. This way the intake/exhaust rocker arms will not move even if the crankshaft is turned clockwise or counterclockwise from the TD mark.

5. Troubleshooting

5.1 Troubleshooting

1. **No fuel injection sound**

[Engine allows easy manual rotation]

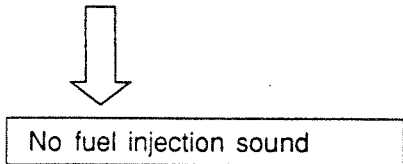
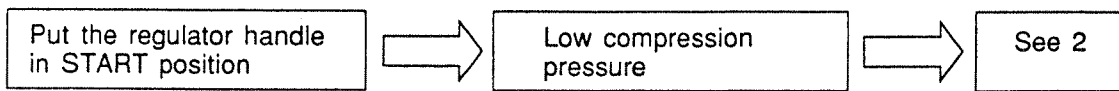

Trouble	Possible causes	Remedy
---------	-----------------	--------

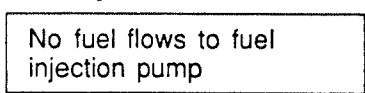

- 1. Fuel tank is empty
- 2. Fuel cock closed
- 3. Clogging in fuel strainer

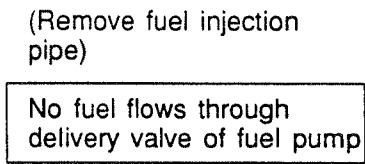
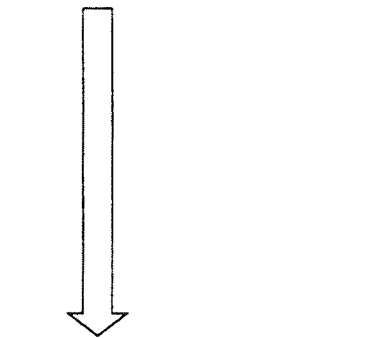

- 1. Air in fuel pump
 - * Push decomp. lever and pull recoil several times with no compression. Hold the high pressure pipe in the same hand as the decomp. lever.
 - Prime and bleed air
 - Methods
 - a. Remove the fuel injection pipe
 - b. Loosen the delivery valve retainer (removal not necessary)
 - c. Open the fuel cock to flow fuel (rotate flywheel half way when no fuel flows)
 - d. Tighten and test delivery valve (check tightening torque)
 - * Replace delivery valve as a set (including packing)
- 2. Dust/flaws in delivery valve seat
 - Clean the delivery valve
- 3. Faulty governor linkage adjustment
 - Adjust the governor linkage (see instructions)
- 4. Worn fuel pump plunger
 - Replace fuel pump

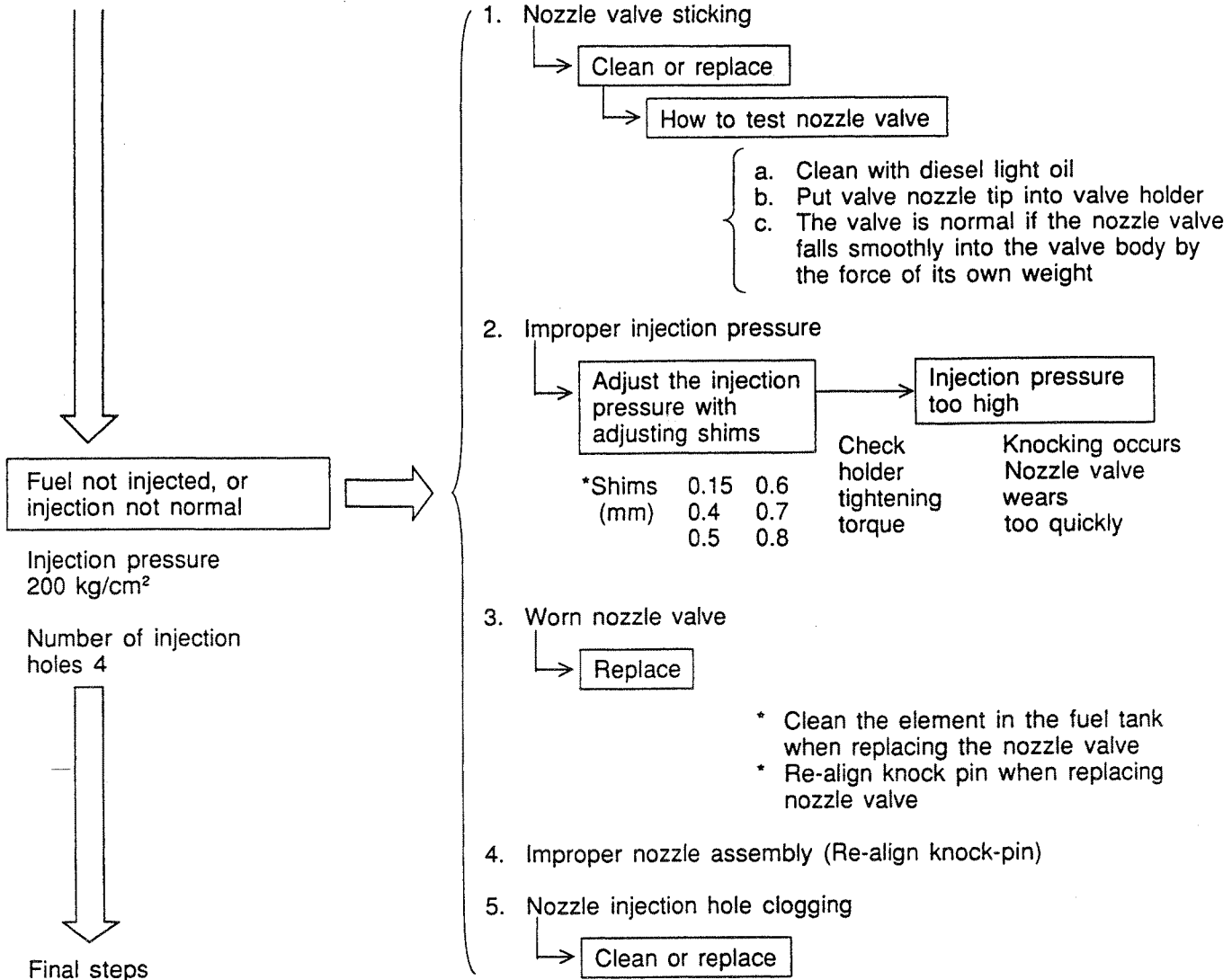

2. **Low compression pressure**

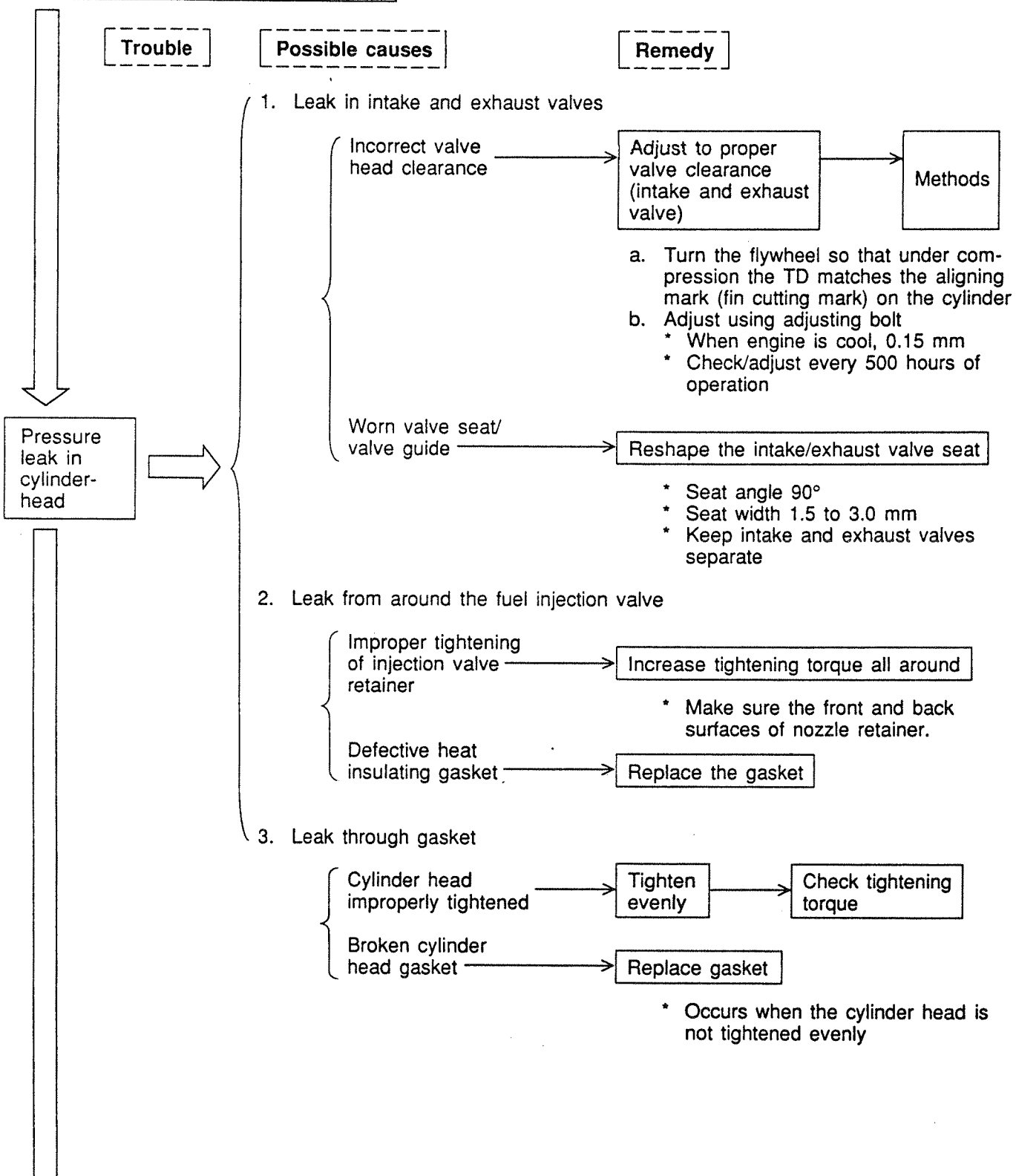

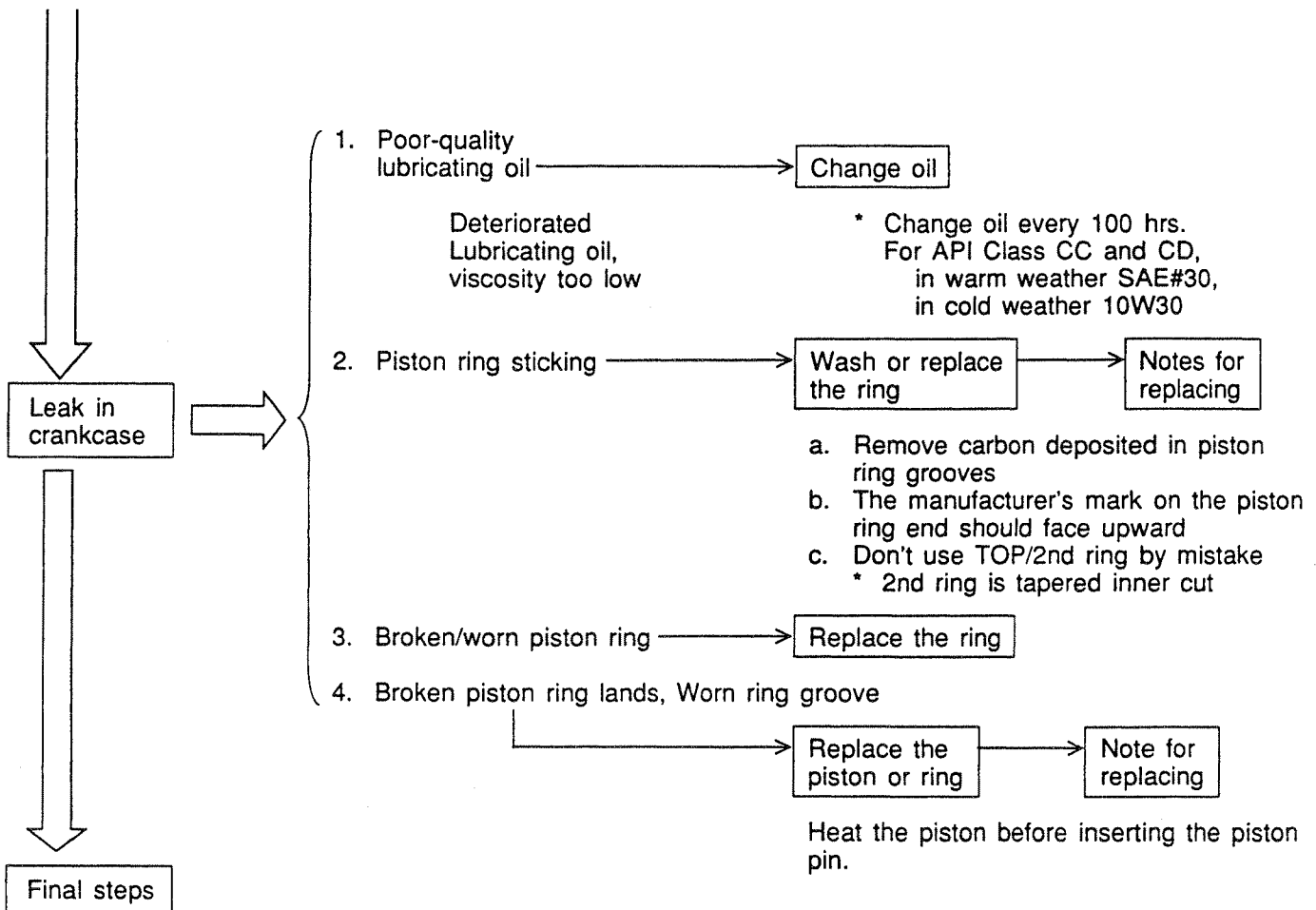

3. Recoil too heavy

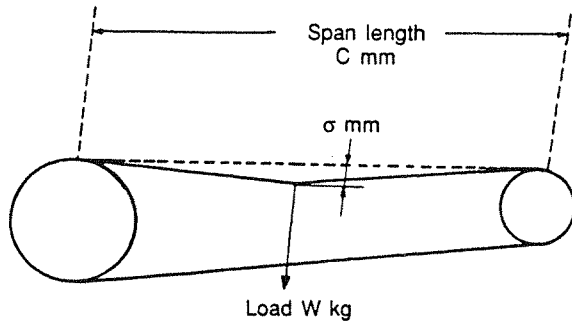

Belt type	Load W kg			Small pulley dia. (mm)
	W	1.3W	1.5W	
A	1.1	1.4	1.7	ø91~105
B	1.8	2.3	2.7	ø136~160

- a. Obtain $\sigma = 0.016 \times C$
- b. Measure the load when belt deflection is σ mm. If the load falls between W and $1.3 \times W$ as shown in the table, tension is correct. Apply $1.5 \times W$ to a new belt first installed.

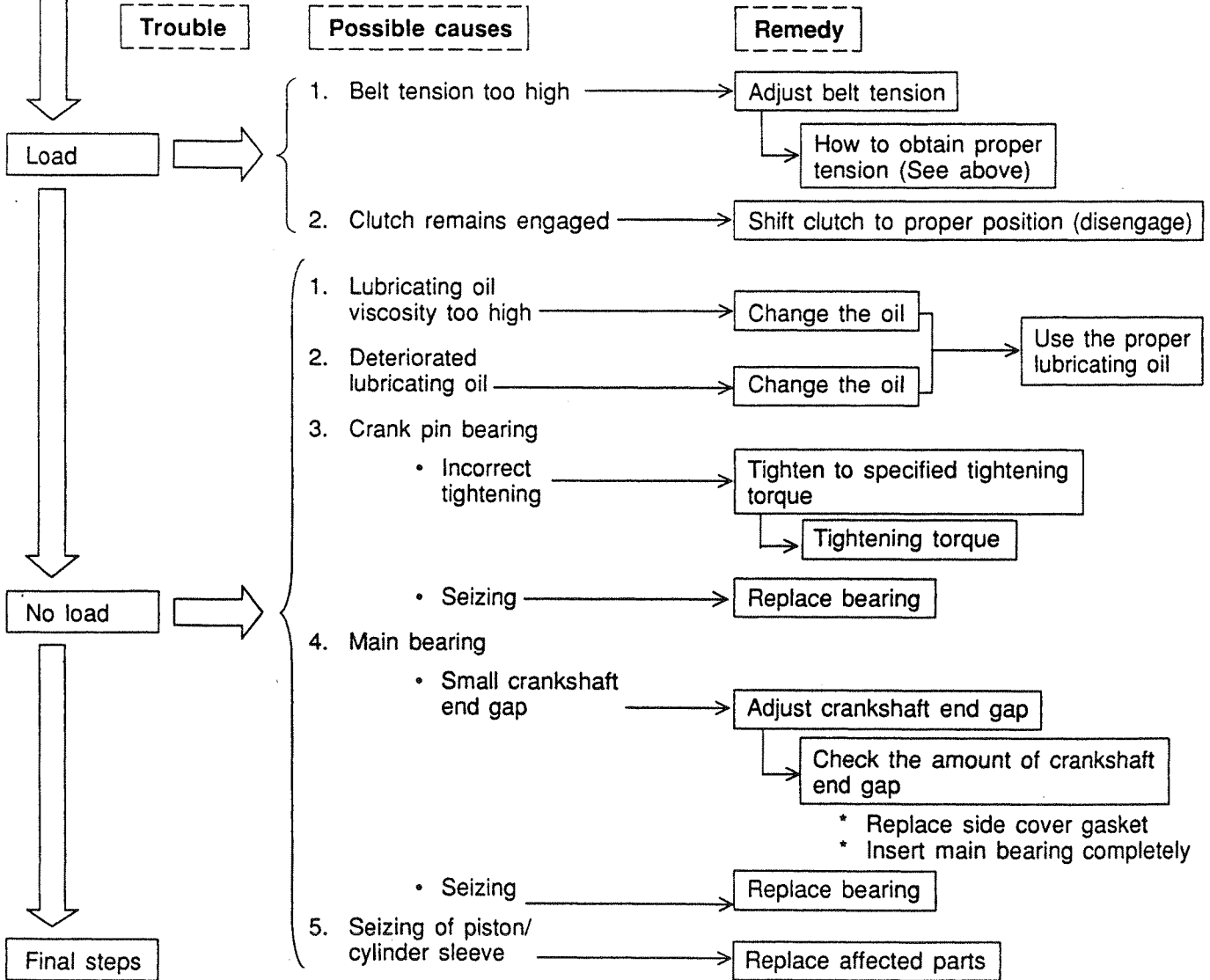

4. **Failure of starter motor (starter)**

Trouble	Possible causes	Remedy
Starter will not turn	1. Loosened or corroded battery terminal	Reconnect battery terminal. Repair corroded terminal.
	2. Discharged battery	Charge battery or replace (For improperly charged battery, refer to 5.)
	3. Malfunction of or improper wiring to key switch	Check key switch and replace if necessary. Repair wiring.
	4. Malfunction of starter relay.	Check key switch and replace if necessary. Repair wiring.
	5. Malfunction of magnetic switch	Check wiring to magnetic switch. Repair if necessary.
	6. Pinion incorrectly engaged with ring gear	<ul style="list-style-type: none"> Adjust l dimension when pinion comes out. Check shift lever for deformation, return spring for fatigue, and pinion for sliding. Repair or replace as required. Correct engagement of pinion with ring gear. Replace if necessary.
	7. Discrete starter turns when its M terminal is connected to battery?	(No) Replace rotor and/or starter (Yes) Replace magnetic switch, whose contact is faulty
	8. Engine seizure	Check engine. Replace as required.
Starter itself turns but engine will not	1. Refer to items 6. listed above	
	2. Broken pinion roller clutch	Check pinion roller clutch. Replace if necessary.
Starter turns sluggishly	1. Refer to items 1 and 2 listed above	
	2. Engine oil has abnormal viscosity	Replace engine oil with proper one.
	3. Engine is overloaded by driver machine	Check clutch for ON/OFF operation. Check drive belt for tension.
	4. Engine encounters great sliding resistance	Check engine. Repair it or replace defective parts.

Most starter failures are attributed to damage caused by an overrun and a fused contact of the magnetic switch. The following table enumerates the symptom, condition, and cause of such failures.

Troubleshooting

	Symptom	Condition	Cause
Damage due to overrun	<ol style="list-style-type: none"> 1. Engine generates abnormal sound during operation. 2. Starter fails to start smooth. 3. Wire harness is fused (caused by short-circuited wiring in starter). 4. Key switch is turned OFF but engine is still cranked. 	<ol style="list-style-type: none"> 1. Motor is internally burnt. 2. Commutator breaks and scatters. 3. Pinion clutch is discolored. Grease scatters. 4. Magnetic switch coil is burnt. Odors occur and plunger sticks. 	<ol style="list-style-type: none"> 1. Key switch fails to return smooth caused by a bent key or dust deposited on key circumference. 2. Intermediate relay has contact fused. 3. Key switch is repeatedly operated because of misfire of engine.
Fused contact of magnetic switch	<ol style="list-style-type: none"> 1. Refer to 1 to 3 listed above. 2. Key switch is turned OFF but starter will not stop. (Engine is not cranked.) 	<ol style="list-style-type: none"> 1. Refer to 1, 2 and 4 listed above. (Note that pinion clutch is free from trouble.) 	<ol style="list-style-type: none"> 1. Battery is discharged because of sparks that result from repeated ON/OFF operation of magnetic switch. 2. Wire harness stacks off. 3. High impedance at switchings circuit. 4. Small pinion gap that may cause spark when the contact closure is opened by such as vibration.

5. **Insufficiently charged battery**

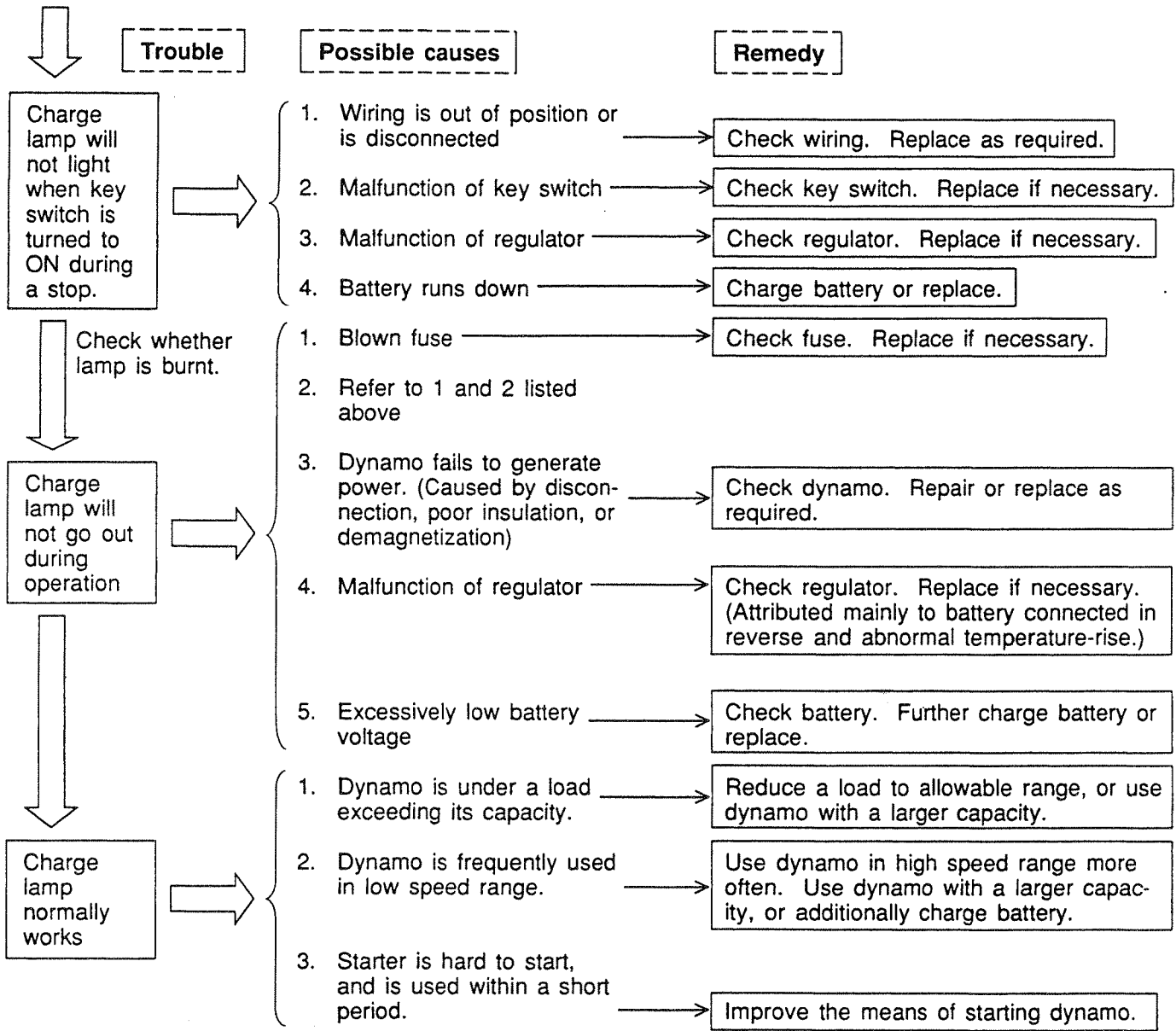

6. Normal fuel injection and compression and light recoil, but engine is still hard to start.

If the engine is hard to start even when injection and compression are normal, the recoil is light, and ambient temperature are normal, check the following in order.

Causes and Remedies

Main causes	Remedies	Special Instructions
1. Improper fuel oil (1) Low-quality fuel (2) Water in fuel	(1) Use a different fuel (2) Replace fuel	(1) Using the recommended fuel oils (2) Observe proper handling, storage and draining procedures
2. Incorrect timing of opening and closing of intake and exhaust valves (1) Valve head clearance too large	(1) Adjust intake and exhaust valves	(1) How to adjust intake and exhaust valves
3. Inaccurate injection timing (1) Improper thickness of adjusting shim (2) Improper injection pressure (3) Worn plunger	(1) Adjust thickness of adjusting shim (2) Adjust injection pressure (3) Replace plunger	(1) Adjust injection timing (2) How to adjust injection pressure (3) Proper handling of fuel oil
4. Faulty spray from fuel injection valve (1) Nozzle valve sticking (2) Flaw on nozzle valve (3) Low injection pressure (4) Worn nozzle valve (5) Clogged injection hole	(1) Wash or replace valve (2) Replace valve (3) Adjust injection pressure (4) Replace valve (5) Wash or replace valve	(1) Observe proper handling, storage and drainage procedures (2) Adjust injection pressure
5. Carbon deposits on nozzle tip (1) Clogged nozzle injection hole	(1) Remove carbon	(1) Proper handling of fuel oil using the specified fuel
6. Top clearance too large (1) Worn bearings	(1) Replace the bearings	(1) Proper handling of lubricating oil

5.2 Unexpected Reverse Rotation at Startup

Model L-A engine reverse owing to the reverse preventive camshaft. Starting such an engine without sufficiently pulling the recoil may cause the engine to reverse. If the engine is continuously run as it is, the lubri-

cating oil pump reverses accordingly, thus failing to feed lubricating oil and causing the bearing metal to seize. If the engine reverses, immediately stop the engine using the accelerator lever or decompression lever.

Reverse rotation of engine

Causes and remedies

Main causes	Remedies	Special Instructions
1. Improper starting procedure (1) Slow manual turns	(1) Turn faster correct assembly	Proper starting procedure
2. Hard to turn manually	See 5.1, 3.	
3. Fuel injection timing too fast (1) Adjusting shims not thick enough (2) Improper alignment with gear matching mark	(1) Add adjusting shims to correct injection timing (2) Reassemble	Adjustment of injection timing

5.3 Racing

If engine starts racing during startup or operation, stop the engine immediately with the regulator or decompression lever. Contin-

ued running can lead to major troubles. Racing is due to a malfunction in the governor system.

Possible causes.

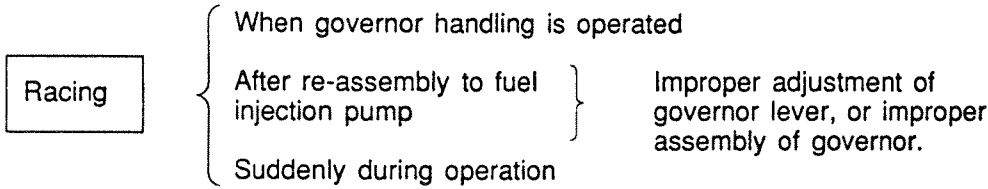

Causes and remedies

Main causes	Remedies	Special Instructions
1. Regulator handle operates too fast	Adjust governor lever Check and adjust position of regulator spring	Proper operation of control handle How to adjust governor lever
2. Improper adjustment of governor lever (1) Improper adjustment (2) Loose bolt on pump adjusting lever	Adjust governor lever	How to adjust governor lever
3. Governor weight malfunction (1) Governor weight malfunction	(1) Repair	

5.4 Uneven Rotation

Uneven rotation (hunting) lowers engine performance and work efficiency.

Main causes of uneven rotation are:

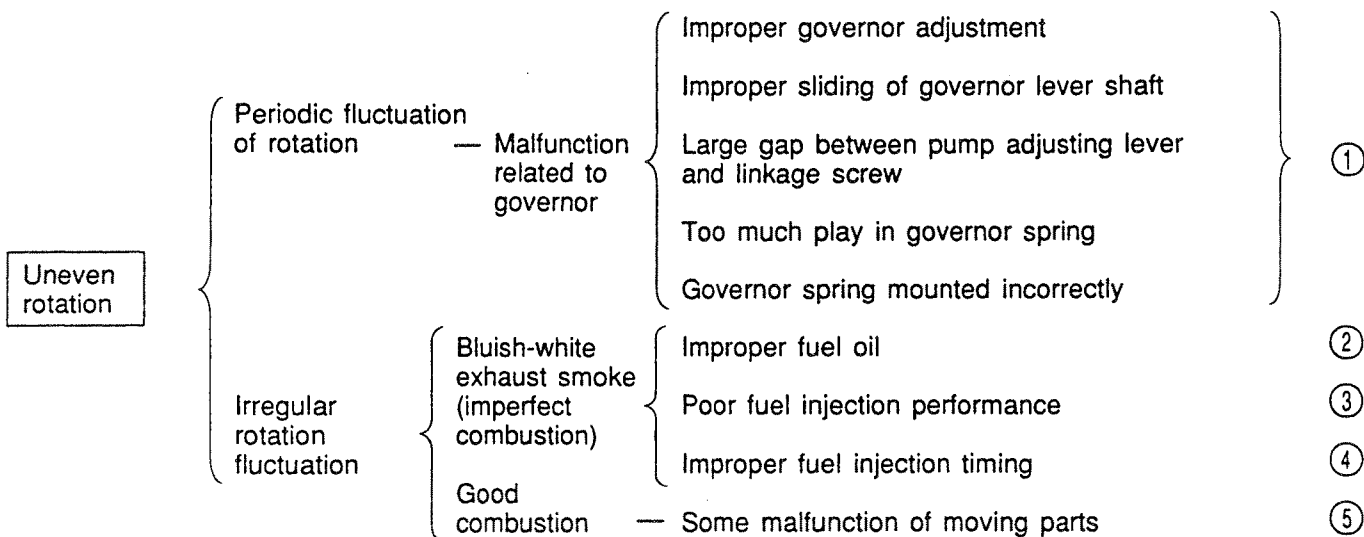

Causes and remedies

Main causes	Remedies	Special Instructions
① Malfunction related to governor (1) Poor performance related to governor lever a. Improper governor adjustment b. Improper sliding of governor lever shaft c. Governor lever interference (2) Faults in the governor a. Loose bolt b. Poor weight action c. Too much play in spring fitting (3) Regulator spring incorrectly positioned	(1) Adjust or replace a. Adjust governor b. Lubricate or repair c. Repair or replace (2) Adjustment a. Increase the tightening torque b. Repair c. Adjust play of spring (3) Adjust the mounting position	(1) Adjusting method a. How to adjust governor
② Low quality or contaminated fuel oil	Changed to specified fuel	Procedure for selecting and handling fuel oil
③ Poor fuel injection performance (1) Nozzle sticking (2) Worn/damaged nozzle valve seat (3) Low injection pressure	(1) File or replace the nozzle (2) Same as (1) (3) Adjust injection pressure	Methods of handling fuel oil
④ Too fast/too slow fuel injection timing	Adjust injection timing using adjusting shim	Adjusting fuel injection timing
⑤ Malfunction of moving parts (1) Camshaft side gap too large (2) Loose end nut	(1) Replace side cover packing (2) Increase tightening torque	(1) Pulley centering and adjusting of belt tension (2) Stress importance of regular re-tightening

5.5 Output Drops

When an engine is required to work beyond its capacity, rotation speed drops and it emits a thick, black exhaust smoke. If this happens during

normal load operation, something is wrong with the engine. Turn off the engine and try to find the cause.

Check the following:

Output drops

Abnormal exhaust color (black or bluish white)

Abnormal operating sound (other than exhaust)

- Improper fuel injection ①
- Pressure leak ② See 5.1, 2.
- Fuel-related problems ③
- Air cleaner clogging ④
- Carbon deposits in combustion chamber ⑤
- Clogging in cooling air intake ⑧
- Clearance between intake/exhaust valves too large ⑥
- Bearing metal seizing and Liner/piston seizing ⑦

Causes and remedies

Main causes	Remedies	Special Instructions
① Improper fuel injection (1) Nozzle sticking (2) Worn nozzle (3) Low injection pressure (4) Worn plunger (5) Insufficient oil tightness in delivery valve (6) Improper governor adjustment (7) Nozzle injection hole clogged	(1) File or replace (2) Replace the nozzle (3) Adjust injection pressure (4) Replace the nozzle (5) Repair or replace (6) Adjust governor (7) Wash or replace nozzle	(1)-(5) Handling fuel oil (6) Adjusting governor
② Pressure leaks	See 5.1, 2.	
③ Fuel-related problems (1) Low quality fuel (2) Out of fuel (3) Fuel strainer clogged	(1) Change to specified fuel. (2) Add fuel and bleed air from fuel pump (3) Clean inside fuel tank and clean or replace filter element.	Use the specified fuel. Proper handling of fuel oil.
④ Air cleaner element clogged	Clean air cleaner	Handling of air cleaner
⑤ Carbon deposits in combustion chamber	Remove carbon	Handling of fuel oil
⑥ Clearance between intake/exhaust valves too large	Adjust the gap	Adjusting intake/exhaust valve clearance
⑦ Malfunction of moving parts (1) Seizing/wear of cylinder liner/piston (2) Seizing/wear of crank pin (3) Seizing/wear of crank bearing (4) Seizing/wear of piston pin	(1) Repair or replace (2) Repair or replace (3) Repair or replace (4) Repair or replace	Handling of lubricating oil
⑧ Insufficient cooling air	(1) Clean cooling air inlet (2) Clean cylinder rib	

5.6 Sudden Stops during Operation

Sudden engine stops during operation are usually due to seizures of moving parts because of improper cooling or lubrication. These, in turn, are caused by carelessness on the part of the operator.

Once the engine breaks down, repairs are costly and time-consuming. To avoid these problems, take good care of your engine.

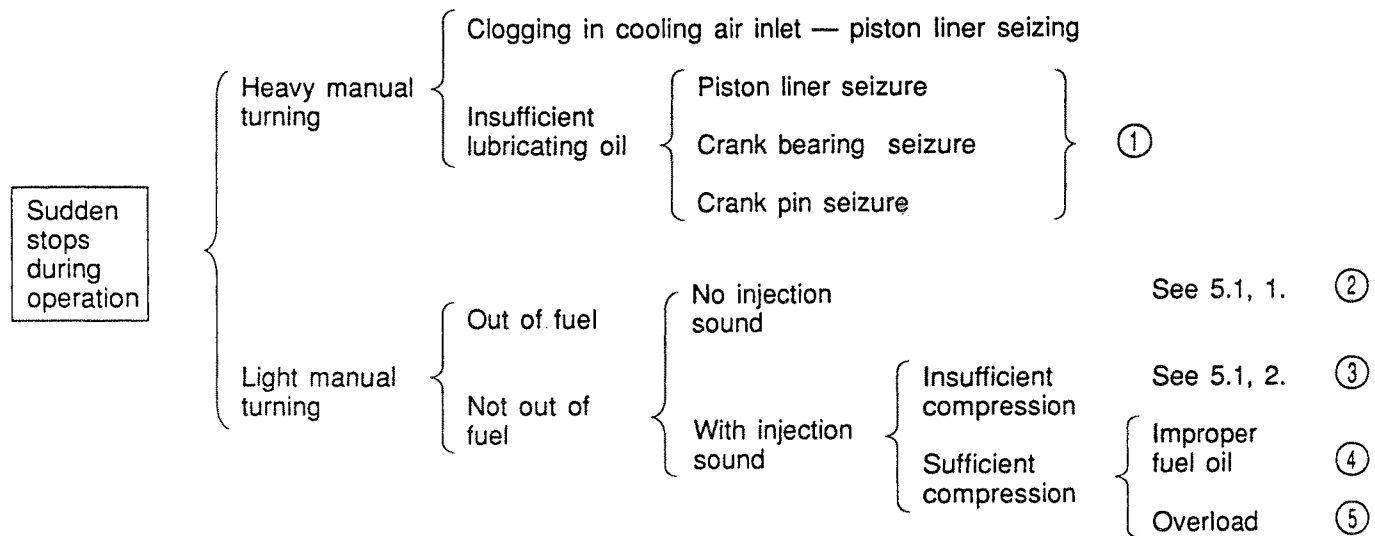

Causes and remedies

Main causes	Remedies	Special Instructions
① Heavy manual turning (1) Crank bearing seizure (2) Crank pin seizure (3) Piston liner seizure	(1) Repair damage, replace bearing metal, and/or change lubricating oil (2) - Same as above - (3) Repair flaw or replace liner	(1) Handling of lubricating oil (2) - Same as above - (3) Handling of lubricating oil. Stress importance of avoiding overload operation
② No fuel injection sound	See 5.1, 1.	
③ Improper fuel oil	See 5.1, 2.	
④ Improper fuel oil (1) Out of fuel (2) Low quality fuel (3) Water in fuel	(1) Add fuel and bleed air from pump (2) Change to specified fuel (3) Drain fuel tank and change fuel	
⑤ Overload	Reduce load	Stress importance of avoiding overload operation

5.7 Abnormal Exhaust Color

Exhaust color is an excellent way to tell what kind of condition your engine is in. In normal weather, before the engine warms up fully, because of incomplete combustion the engine exhausts a black or bluish-white smoke. As the engine reaches normal operating temperature, the exhaust becomes clear or light blue, provided there are no problems. But if

the exhaust does not clear up, a problem is indicated, and the color of the exhaust gives a good idea of where the trouble is. When the exhaust color is abnormal, turn off the engine, locate the problem, and take the appropriate action. Use the following to help you.

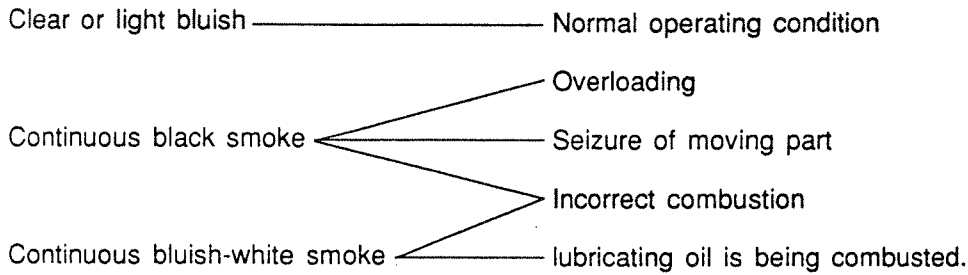

Causes of abnormal exhaust color are:

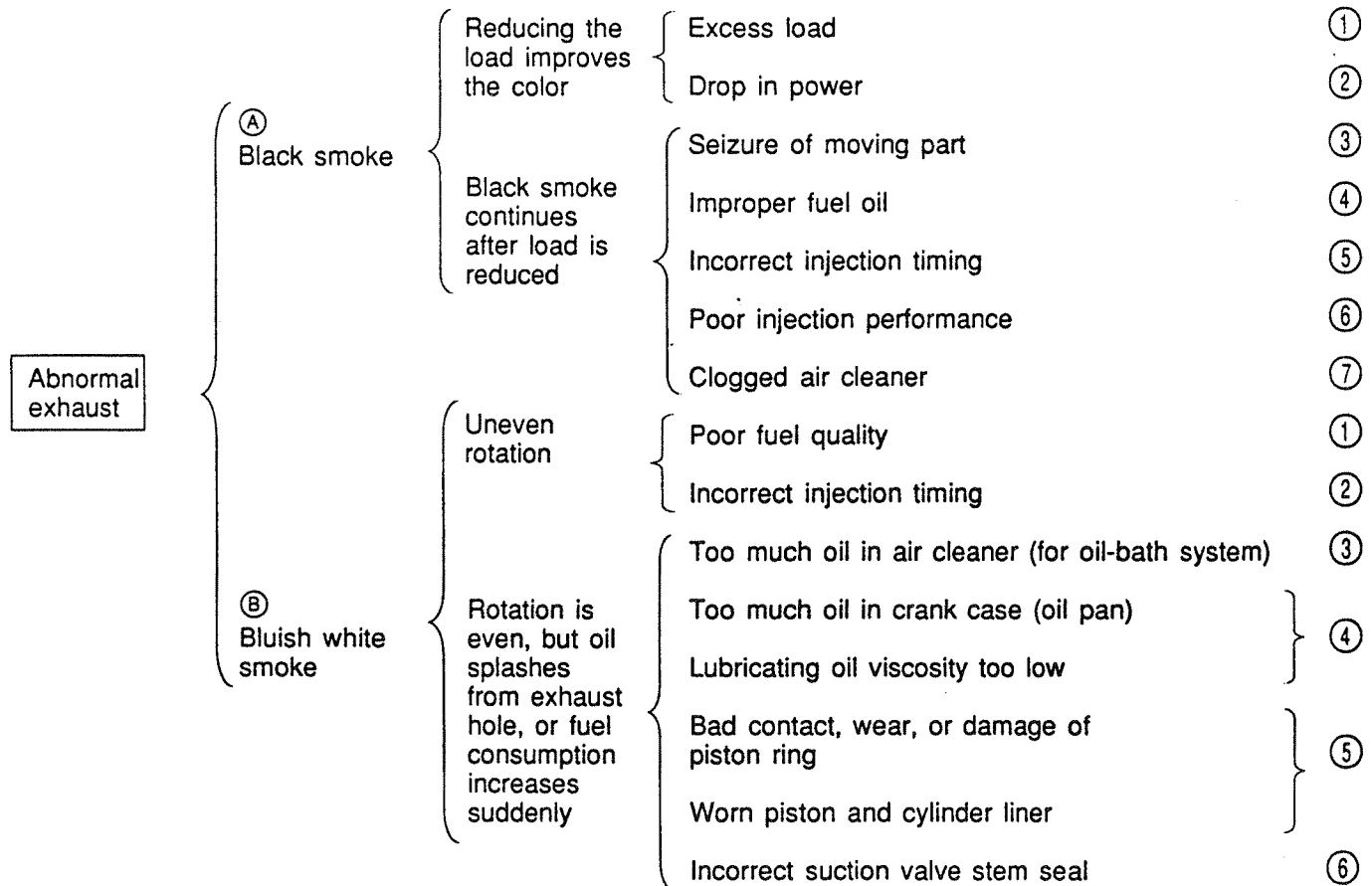

A. Black exhaust

Main causes	Remedies	Special Instructions
① Abnormal operating conditions (1) Operated at overload (2) Belt too tight (3) Improper pulley diameter	(1) Reduce load (2) Adjust belt tension (3) Replace pulley	(1) Working procedure (2) Procedure for adjusting belt tension (3) Selection of pulleys
② Power drops	See 5.5	
③ Seizure of moving part (1) Piston/cylinder liner seizure (2) Crank pin bearing metal seizure (3) Crank bearing metal seizure	(1) Repair or replace piston/cylinder liner (2) Replace the metal (3) Replace the metal	(1) Cleaning of cooling air passage; Handling of lubricating oil (2) Handling of lubricating oil (3) Same as above
④ Low fuel oil quality	Change fuel	Use of specified fuel
⑤ Injection timing too slow	Adjust by reducing adjusting shims	Adjustment of injection timing
⑥ Poor fuel injection performance (Straight shape) (1) Nozzle sticking (2) Worn/damaged nozzle valve seat (3) Injection pressure too low (4) Clogged injection hole	(1) Grind or replace nozzle (2) Same as above (3) Adjust injection pressure (4) Wash hole or replace nozzle	(1) Handling of fuel oil (2) - Same as above - (3) Adjustment of injection pressure
⑦ Clogged air cleaner element	Replace air cleaner element	Periodically check and replace air cleaner

B. Bluish-white exhaust

Main causes	Remedies	Special Instructions
① Low quality fuel oil	Change fuel oil	Use of specified fuel
② Injection timing too slow	Adjust by removing adjusting shims	Adjustment of injection timing
③ Failure to check air cleaner (1) Too much oil in bath	(1) Reduce oil to limit line	Handling of air cleaner Periodical check and cleaning
④ Improper lubricating oil (1) Too much oil in crank case (2) Viscosity too low	(1) Reduce oil to upper limit of dipstick (2) Change lubricating oil	Handling of lubricating oil
⑤ Malfunction related cylinder assembly (1) Wear/fracture of piston ring (2) Worn piston (3) Worn cylinder liner	(1) Replace piston ring (2) - Same as above - (3) - Same as above -	Handling of lubricating oil
⑥ Defective valve stem seal (having only suction)	(1) Replace stem seal	

6. Test Run

6.1 BEFORE STARTING

- (1) Check bolts and nuts and flywheel rotation
 - 1) Check for loose lock bolts and nuts.
 - 2) Turn the decompression lever in the noncompression direction. While turning the recoil starter several times, pay attention to abnormal sounds.

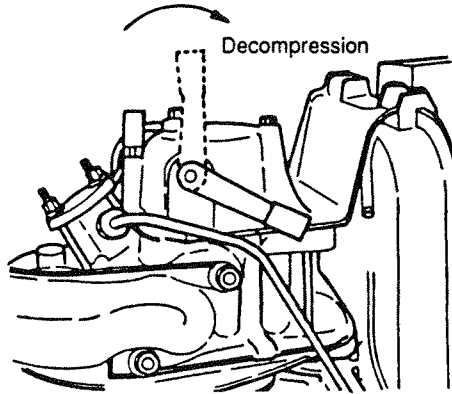

Decompression mechanism

(2) Fuel

Open the drain cock and run out a small amount of fuel since water and other contaminants settle on the bottom.

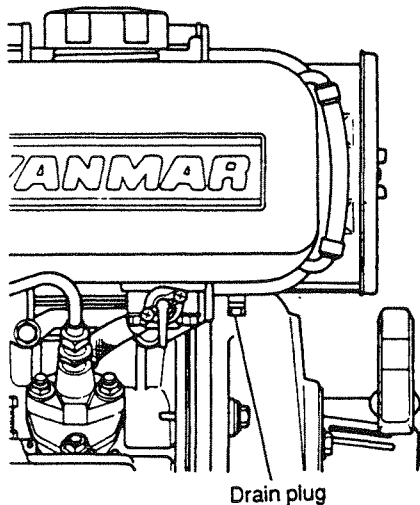

Fuel tank assembly

- (3) Lubricating oil
 - 1) Use the specified lubricating oil.

CAUTION:

Never mix different brands of lubricating oil.

- 2) Fill up the lubrication oil to the filler port (with the engine horizontal)
- (4) Priming with lubricating oil

Turn the flywheel as follows to make sure oil gets to all engine parts.

 - 1) Set the speed control handle to the STOP position.
 - 2) Set the decompression lever to the "Non compression" position.
 - 3) Turn the flywheel.

(Make sure no abnormal sound occurs.)

6.2 STARTING

- (1) Set the fuel cock to position "O" (open).

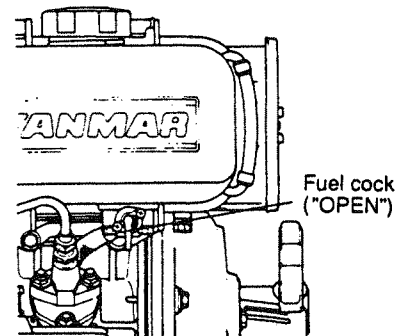

(This figure shows the operating position.)

Starting (1)

- (2) Set the regulator handle to the "START" position, and tighten the knob. (The FO limiter must be in the "increase" position. Otherwise, the engine may not start.)

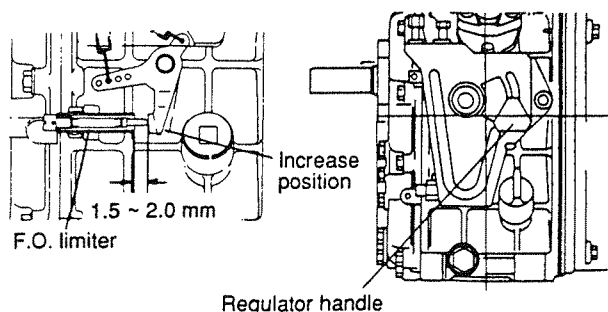

(This figure shows the starting position.)

Starting (2)

- (3) Pull out the recoil starter handle.
- 1) Pull out the recoil starter handle grip slowly until it feels tight to pull, then let it back slowly.
 - 2) Turn the decompression lever to "Non compression" by one hand.
The decompression lever returns automatically when the recoil starter handle is pulled.

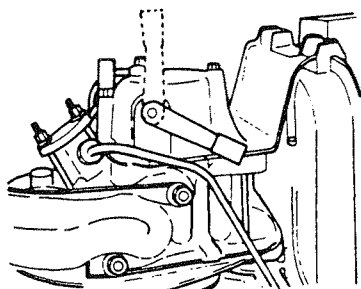

Starting (3) - 2)

- 3) Grip the recoil starter handle with both hands and give a good, strong pull.

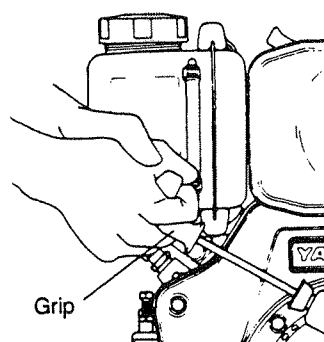

Starting (3) - 3)

- 4) If it is hard to start the engine in cold weather, remove the rubber plug on the valve rocker arm cover. Add about 2 cc of lubricating oil to aid starting. (L40AE - L70AE only). Do not apply this operation to L75AE to 100AE. Otherwise, the recoil requires a stronger pulling force and the engine becomes more difficult to start. Since this rubber plug is not necessary for engines for tropical countries, a blind plug is provided on those types instead.

CAUTION:

Keep the plug in the hole when it is not in use to block out water, dust, etc. If the plug is left out, rainwater and dirt intrude to cause early wear of engine and other troubles. Never add too much oil.

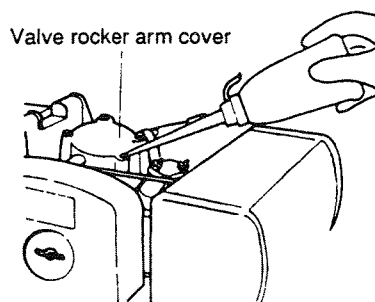

Add oil as starting aid

6.3 OPERATION

- (1) Warmup the engine for about 5 minutes.
- (2) When the engine is warm, put the speed control handle in the required rpm position, and tighten the knob.

6.4 STOPPING

- (1) Turn the speed control handle to the low speed position. Run the engine in no-load state for about 5 minutes.
- (2) Turn the speed control handle to "STOP".

CAUTION:

Always allow the engine to cool off before stopping.

- (3) Return the fuel cock lever to "S" (close).
- (4) Pull out the recoil starter handle slowly, then stop pulling when it feels tight.

7. Helical Inserting Part for Repair

1. Helical inserting part for repair

- 1) The "helical inserting part for repair" is the generic name for the helical inserting part and its special-purpose tool; it is a kind of special threaded bushing.
- 2) The helical inserting part is used for repairing broken bolts and worn-out female screw.
- 3) Shape and name
The helical inserting part has a shape like a spring coil. It is made of a wire rod with a rhombic cross section as illustrated.
- 4) Use
Use the helical inserting part as illustrated.

- 5) The helical inserting part should usually have a length equal to or greater than the thread length of the bolt.

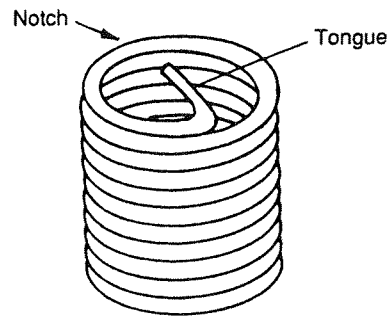

Helical Inserting part

Table 1 shows a part of standard metric threads. Other small threads frequently used include the standard thread M5-P0.9, fine threads M12-P1.25 and M12-P1.5, etc.

Fig. 1 shows the size relationship between the helical inserting part and the thread.

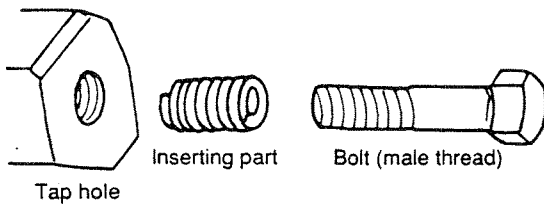

2. Size of helical inserting part

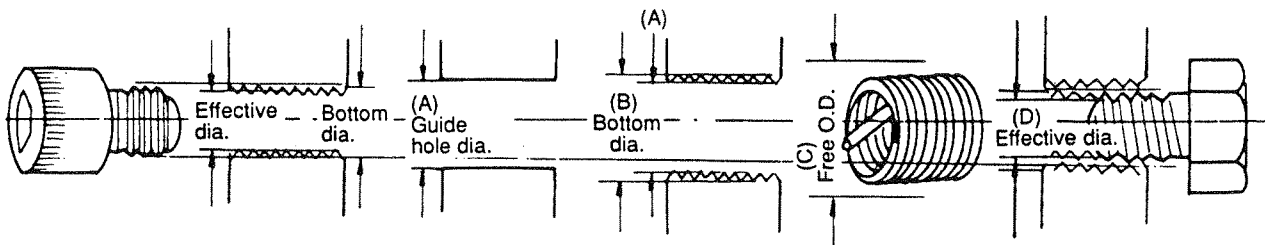

Fig. 1 Dimensions for Helical Inserting part

Standard thread			Helical insert tapping		Helical insert thread		Nominal length (LB)		
Thread size	Effective dia.	Bottom dia.	Guide hole (A)	Bottom dia. (B)	Helical insert Free O.D.(C)	Effective dia. (D)	ID	1.5D	2D
M6-1.0	5.350 (0.211)	6.000 (0.236)	6.3 (0.248)	7.300 (0.287)	7.98-7.47 (0.314-0.294)	5.350 (0.211)	6.00 (0.236)	9.00 (0.354)	12.00 (0.472)
M8-1.25	7.188 (0.283)	8.000 (0.315)	8.4 (0.331)	9.624 (0.379)	10.28-9.73 (0.405-0.383)	7.188 (0.283)	8.00 (0.315)	12.00 (0.472)	16.00 (0.630)
M10-1.5	9.026 (0.355)	10.000 (0.394)	10.5 (0.413)	11.948 (0.470)	12.63-12.07 (0.497-0.475)	9.026 (0.355)	10.00 (0.394)	15.00 (0.591)	20.00 (0.787)
M12-1.75	10.863 (0.428)	12.000 (0.472)	12.5 (0.492)	14.274 (0.562)	14.98-14.34 (0.590-0.565)	10.563 (0.416)	12.00 (0.472)	18.00 (0.709)	24.00 (0.945)
M14-2.0	12.701 (0.500)	14.000 (0.551)	14.5 (0.571)	16.598 (0.653)	17.44-16.55 (0.687-0.652)	12.701 (0.500)	14.00 (0.551)	21.00 (0.827)	28.00 (1.102)
M10-1.25	—	—	—	—	12.63-12.07 (0.497-0.475)	—	—	—	—
M14-1.5	—	—	—	—	17.81-17.17 (0.701-0.676)	—	—	—	—

Table 1

3. Procedure for using helical insert part

(1) Drilling

When using the helical inserting part, it is necessary to drill a guiding hole which is slightly larger than the nominal diameter, because the insert occupies the space between the bolt and threaded hole. The size of guiding hole should be "B", which is the usual guiding hole size "A" plus twice the height of the thread "c". This slightly exceeds the outer diameter of the bolt threads. When drilled with a size "B" drill, the original female thread coil is completely stripped off.

The new guiding hole must be drilled according to the depth calculated from the effective thread length of the bolt. If the drill hole is countersunk or spot-faced, the depth should be increased accordingly.

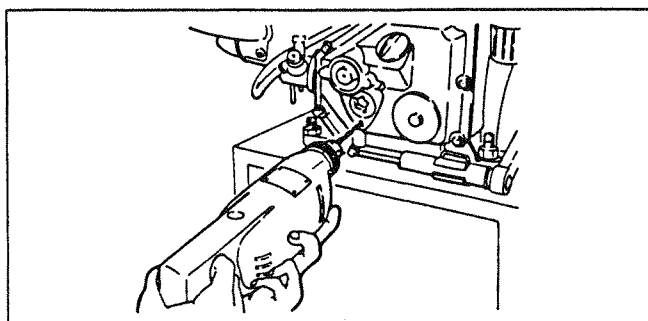

Drilling

(2) Tapping

After the drilling the hole must be tapped with helical insert taps. A helical insert part will be fitted into this new hole and the inner thread matches the originally tapped hole to accept the original bolt. The tapping depth depends on the effective thread length of the bolt. The helical insert tapping must be accomplished in three stages: rough, medium, and finishing tap.

These taps must be applied in this order and centered correctly to avoid the misalignment of threads. When the hole is tapped successfully, thoroughly blow-clean the hole with compressed air before inserting the helical insert part.

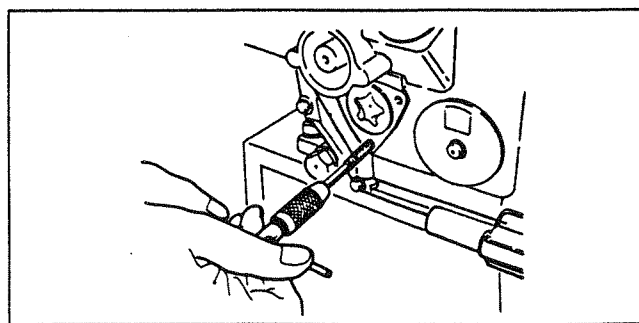

Tapping

(3) Insertion

Apply the helical insert to the hole with the inserting tool, while the tongue is looking downward. Holding down the insert, turn the handle clockwise. Then, the insert is screwed into the hole.

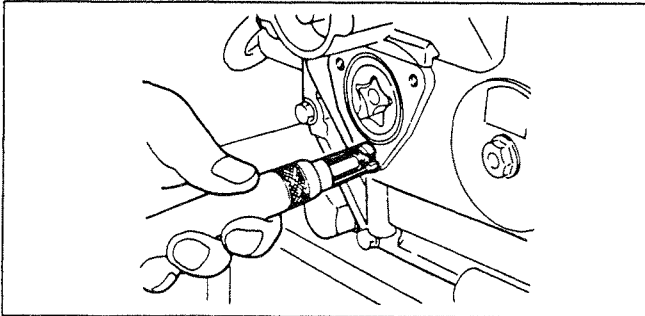

Insertion

(4) Removing the tongue

To remove the tongue, hit the head of the tongue removing tool with a hammer.

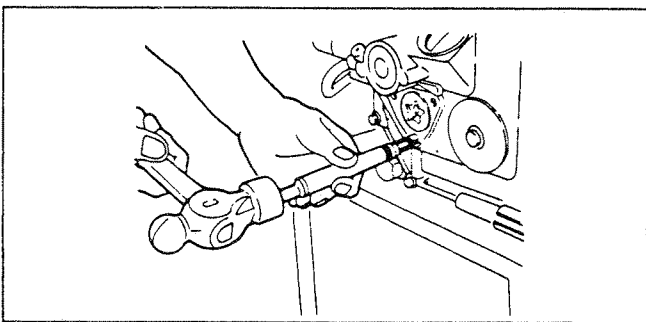

Removing the tongue

(5) Removing the helical insert

It is not necessary to remove the helical insert unless especially required.

The helical insert can be removed by turning it counterclockwise.

4. Where helical insert part can not be used

The helical insert part may be used for all parts, except on the unevenly worn screw of the valve rocker arm support lock bolt on the cylinder head.

Appendix 1 Difference Between Parts under Spec. S and D

Specs.	PTO shaft	Direction of rotation (viewed from PTO side)	
		PTO	Crankshaft
S	Camshaft	Counterclockwise	Clockwise
D	Crankshaft		Counterclockwise

Model L60AE-S ... S spec.
 Model L60AE-D ... D spec.

Users are supposed to place an order for parts specifying the parts code listed in the parts catalog. Take care not to assemble an improper parts on the engine: Some parts available from the catalog are almost or totally the same in shape or profile, and yet quite different in their functions. The differences between the S spec. and D-spec. parts are detailed below.

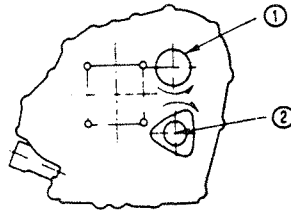
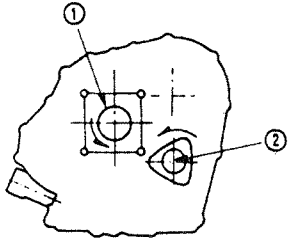
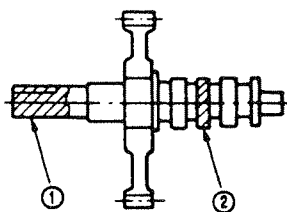
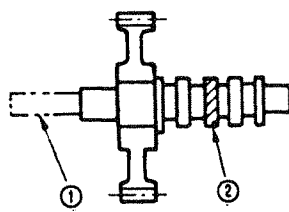
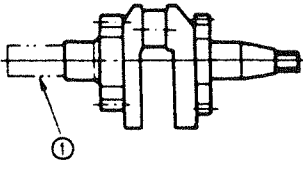
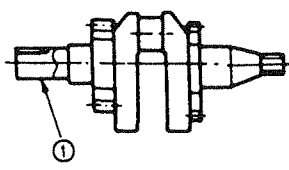
No.	Parts name	Difference	Specification S	Specification D
1	Crank case cover Discrimination P.T.O. shaft hole	(1) P.T.O. shaft hole		
		(2) Direction of LO pump eccentric part	Clock wise	Counterclock wise
2	Camshaft assy Discrimination P.T.O. shaft	(1) Presence or absence of P.T.O. shaft		
		(2) Difference in FO cam phase	Difference in the direction of revolution (with the same profile)	
3	Crankshaft cover Discrimination P.T.O. shaft	(1) Presence or absence of P.T.O. shaft		
			Absence	Presence

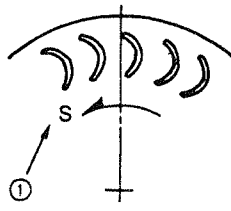
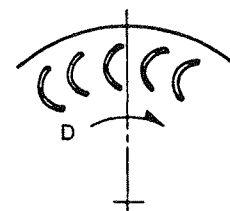
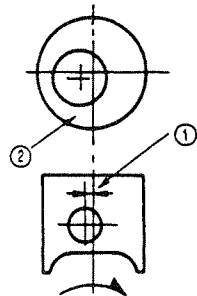
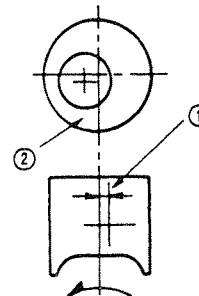
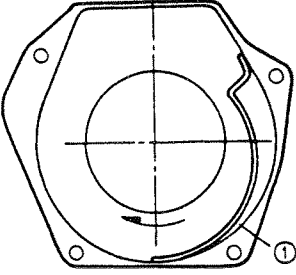
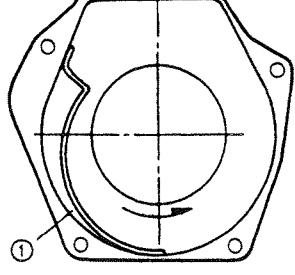
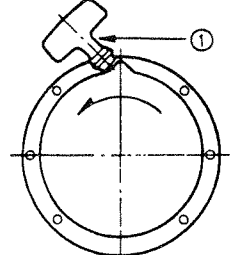
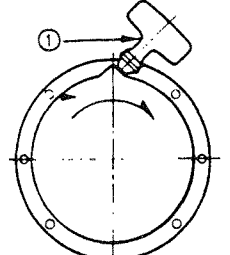
No.	Parts name	Difference	Specification S	Specification D
4	Flywheel Discrimination Embossed mark	(1) Embossed mark (2) Difference in the direction of bent vane	 <p>(View from vane side)</p>	
5	Piston Discrimination	(1) Difference in the offset direction (2) Mark		
6	Cooling fan case Discrimination	(1) Difference in direction of mounting shroud (due to the different directions of cooling fan revolution)	 <p>(Viewed from the rear side)</p>	 <p>(1) Cooling draft guide (shroud)</p>
7	Recoil starter Assembly Discrimination	(1) Difference in the direction of mounting the grip (2) Direction of revolution	 <p>Counterclockwise (viewed from the outside)</p>	 <p>Clockwise</p>

Difference between Parts under Spec. S and D

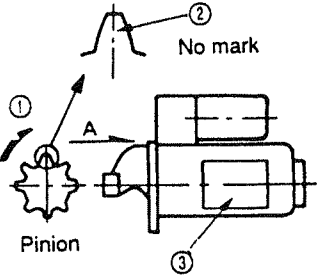
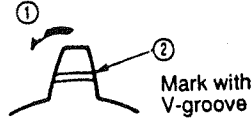
No.	Parts name	Difference	Specification S	Specification D
8	Starting motor	<p>(1) Direction of revolution (viewed from A side)</p> <p>(2) Discrimination V-groove at the pinion end</p> <p>(3) Name plate Manufacturer (Hitachi) Model No.</p>	 <p>Clockwise</p> <p>Absence</p> <p>S114-413A</p>	 <p>Counterclockwise</p> <p>Presence</p> <p>S114-414A</p>

Appendix 2 Details of Special Tools

Oil seal fitting tool

Material: steel
Scale: free

Unit: mm (in.)

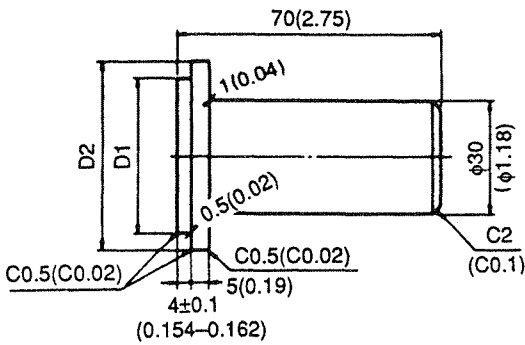

Parts-code	Dimensions	
	D ₁	D ₂
114250-92311	φ 40.8-φ 41 (1.6063-1.6141)	φ 48 (1.89)
114350-92311	φ 44.5-φ 44.7 (1.7520-1.7598)	φ 52 (2.05)
114650-92310	φ 49.5-φ 49.7 (1.9488-1.9567)	φ 58 (2.29)

Oil seal fitting guide

Material: steel
Scale: free

Unit: mm (in.)

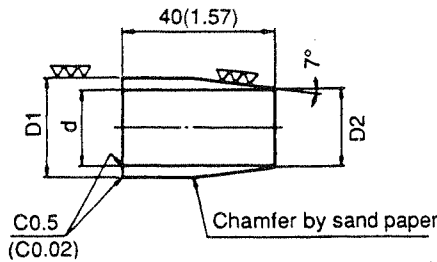

Parts-code	Dimensions		
	d	D ₁	D ₂
114250-92301	20.1-20.2 (0.791-0.795)	25.4-25.5 (1-1.004)	21.4-21.6 (0.843-0.850)
114268-92300	19.1-19.2 (0.752-0.756)	25.4-25.5 (1-1.004)	21.4-21.6 (0.843-0.850)
114350-92301	25.1-25.2 (0.988-0.992)	30.4-30.5 (1.197-1.201)	26.9-27.1 (1.059-1.067)
114368-92300	25.5-25.6 (1.004-1.008)	30.4-30.5 (1.197-1.201)	26.9-27.1 (1.059-1.067)
114650-92300	30.1-30.2 (1.185-1.189)	35.4-35.5 (1.394-1.398)	31.4-31.6 (1.236-1.244)
114668-92300	25.5-25.6 (1.004-1.008)	35.4-35.5 (1.394-1.398)	29.9-30.1 (1.177-1.185)

Valve stem seal fitting tool

Material: steel
Scale: free

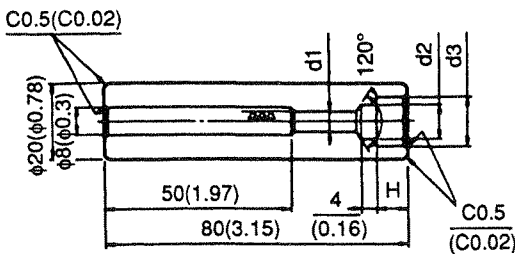

Unit: mm (in.)

Parts-code	Dimensions			
	d ₁	d ₂	d ₃	H
114250-92350	5.5-5.515 (0.2165-0.2171)	9.0-9.2 (0.354-0.362)	12.0-12.2 (0.473-0.480)	9.5-9.7 (0.374-0.382)
114350-92350	6.0-6.015 (0.2362-0.2368)	9.5-9.7 (0.374-0.382)	13.0-13.2 (0.512-0.520)	8.5-8.7 (0.335-0.343)
114650-92350	7.0-7.015 (0.2756-0.2762)	11.5-11.7 (0.453-0.461)	14.0-14.2 (0.551-0.559)	7.5-7.7 (0.295-0.303)

Flywheel tightening handle

Material: steel
 Scale: free
 Unit: mm (in.)

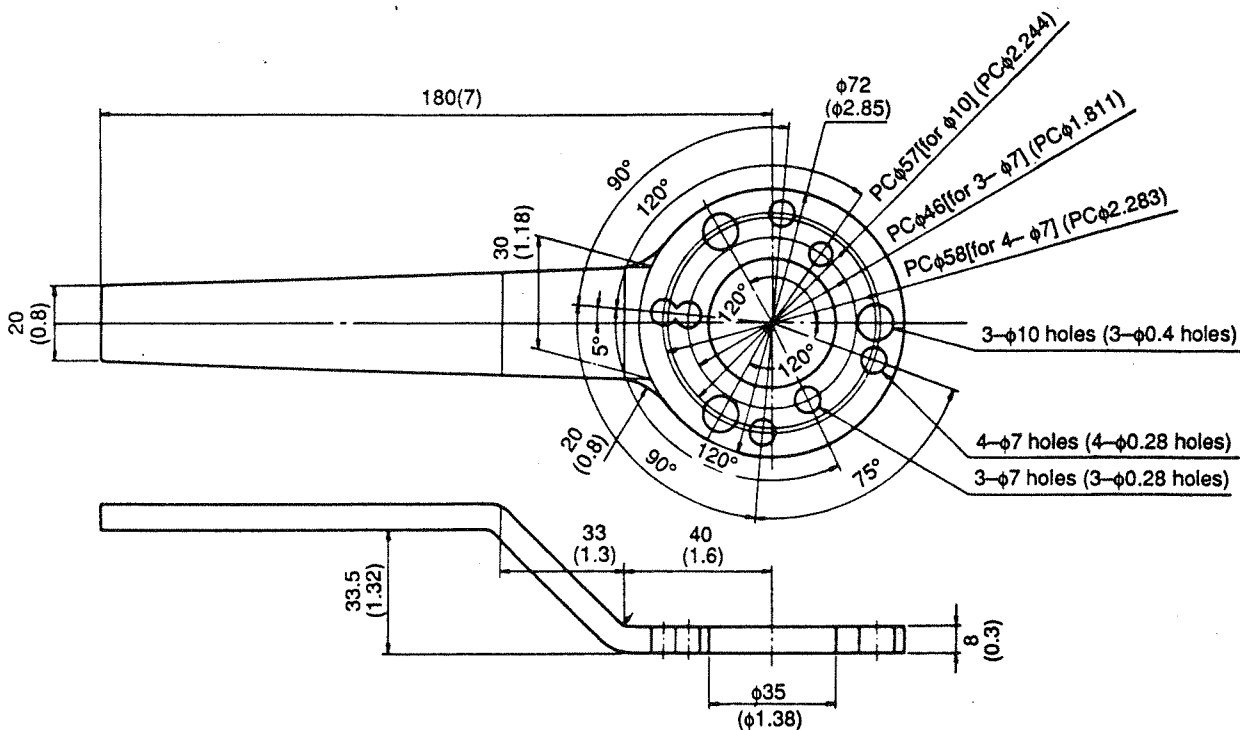

Flywheel extractor

Material: steel
 Scale: free
 Unit: mm (in.)

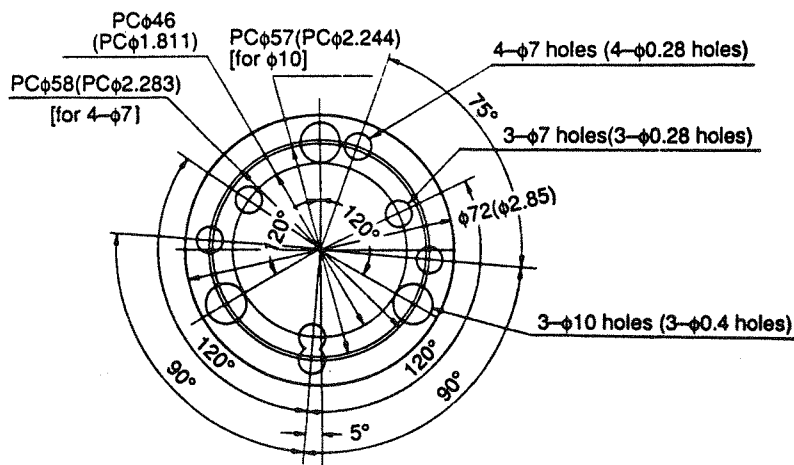

Thickness = 8mm (0.31 in.)

