

REPAIR PARTS

TRACTOR -- MODEL NUMBER LM1236D

ELECTRICAL

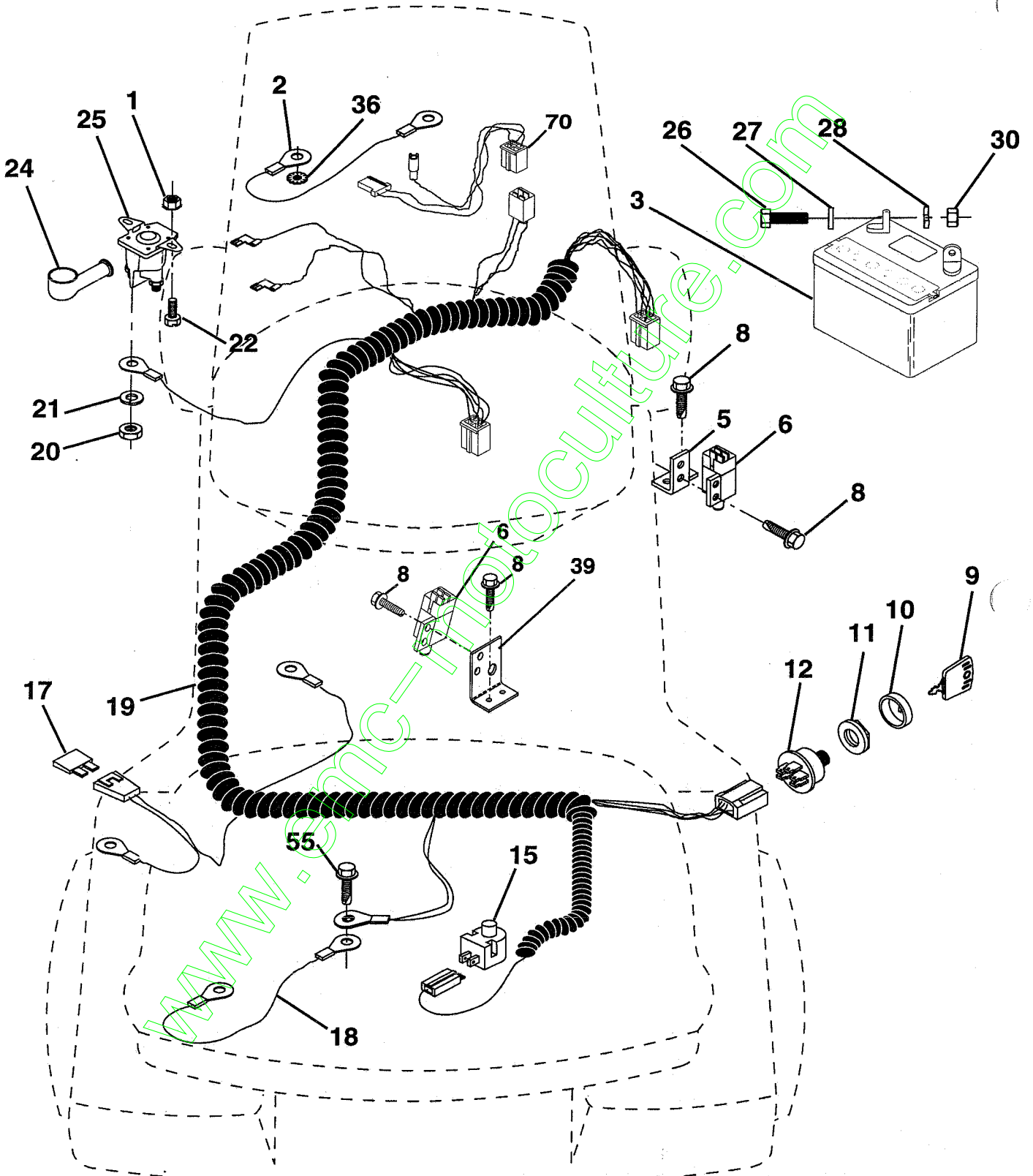

REPAIR PARTS

TRACTOR -- MODEL NUMBER LM1236D

ELECTRICAL

KEY NO.	PART NO.	DESCRIPTION
1	73640400	Nut, Hex, Keps 1/4-20
2	108423X	Assembly, Cable
3	144924	Battery
5	108236X	Bracket, Switch
6	109553X	Switch, Interlock, 4 Terminal
8	17021008	Screw, Hex Head, Self-Tapping #10-24 x 1/2
9	140402	Key, Molded
10	141226	Cover, Ignition Key
11	140400	Nut, Ignition
12	144921	Switch, Ignition
15	121305X	Switch, Plunger
16	73510500	Nut, Hex, Keps 5/16-18
17	108824X	Fuse
18	128353	Assembly, Cable
19	146063	Harness, Ignition
20	73350400	Nut, Hex, Jam 1/4-20
21	10090400	Washer, Lock 1/4
22	71110408	Bolt, Hex, Fin. 1/4-20 UNC x 1/2 Grade 5
24	131563	Cover, Terminal
25	145673	Solenoid
26	74760412	Bolt, Hex Head 1/4-20 UNC x 3/4
27	19091016	Washer 9/32 x 5/8 x 16 Gauge
28	10040400	Washer, Lock 1/4
30	73220400	Nut, Hex, Fin. 1/4-20 UNC
36	11150400	Washer, Lock, Internal Tooth 1/4
39	141735	Bracket Switch Clutch
55	17490508	Screw, Thdrol
70	140413	Harness Engine

NOTE: All component dimensions given in U.S. inches
1 inch = 25.4 mm

HARDWARE SHOWN LARGER FOR EASIER IDENTIFICATION

REPAIR PARTS

TRACTOR -- MODEL NUMBER LM1236D

HOOD

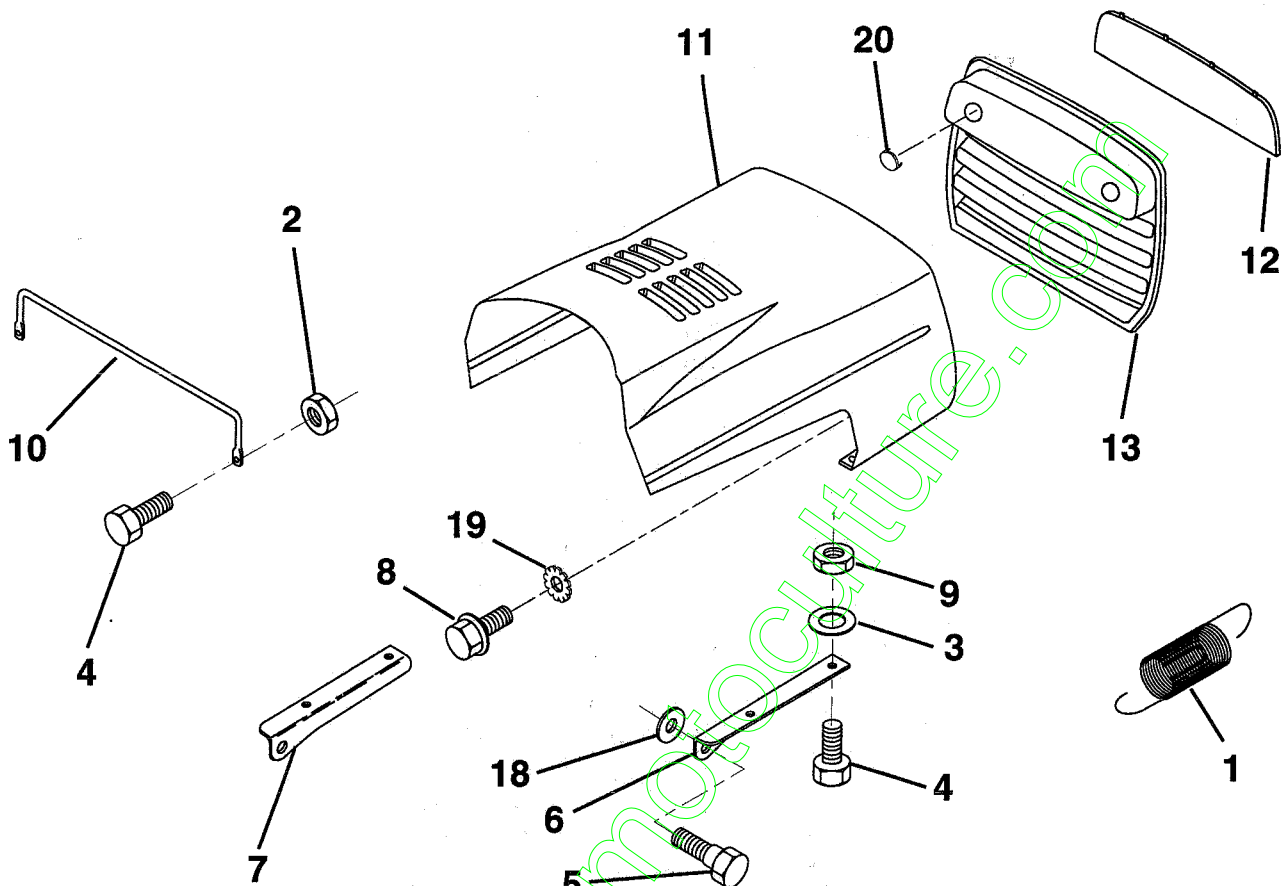

KEY NO.	PART NO.	DESCRIPTION
1	124657X	Spring, Extension
2	73510400	Nut, Hex, Keps 1/4-20 UNC
3	19091416	Washer 9/32 x 7/8 x 16 Ga.
4	74780412	Bolt, Hex, Fin 1/4-20 x 3/4 Grade 5
5	139888	Bolt, Shoulder
6	122549X	Bracket, Hood, R.H.
7	122548X	Bracket, Hood, L.H.
8	17521310	Screw, Sltd. Hex Hd. W/Pl. Washer
9	73800400	Nut, Lock W/Insert 1/4-20

KEY NO.	PART NO.	DESCRIPTION
10	123693X	Brace, Hood
11	132918X505	Hood
12	122035X	Lens
13	127029X	Grill
18	19111116	Washer 11/32 x 11/16 x 16 Ga.
19	11030400	Washer, Lock Ext/Int Tooth 1/4
20	131319	Plug socket

NOTE: All component dimensions given in U.S. inches.
1 inch = 25.4 mm.

HARDWARE SHOWN LARGER FOR EASIER IDENTIFICATION

REPAIR PARTS

TRACTOR - - MODEL NUMBER LM1236D

FENDER / CHASSIS

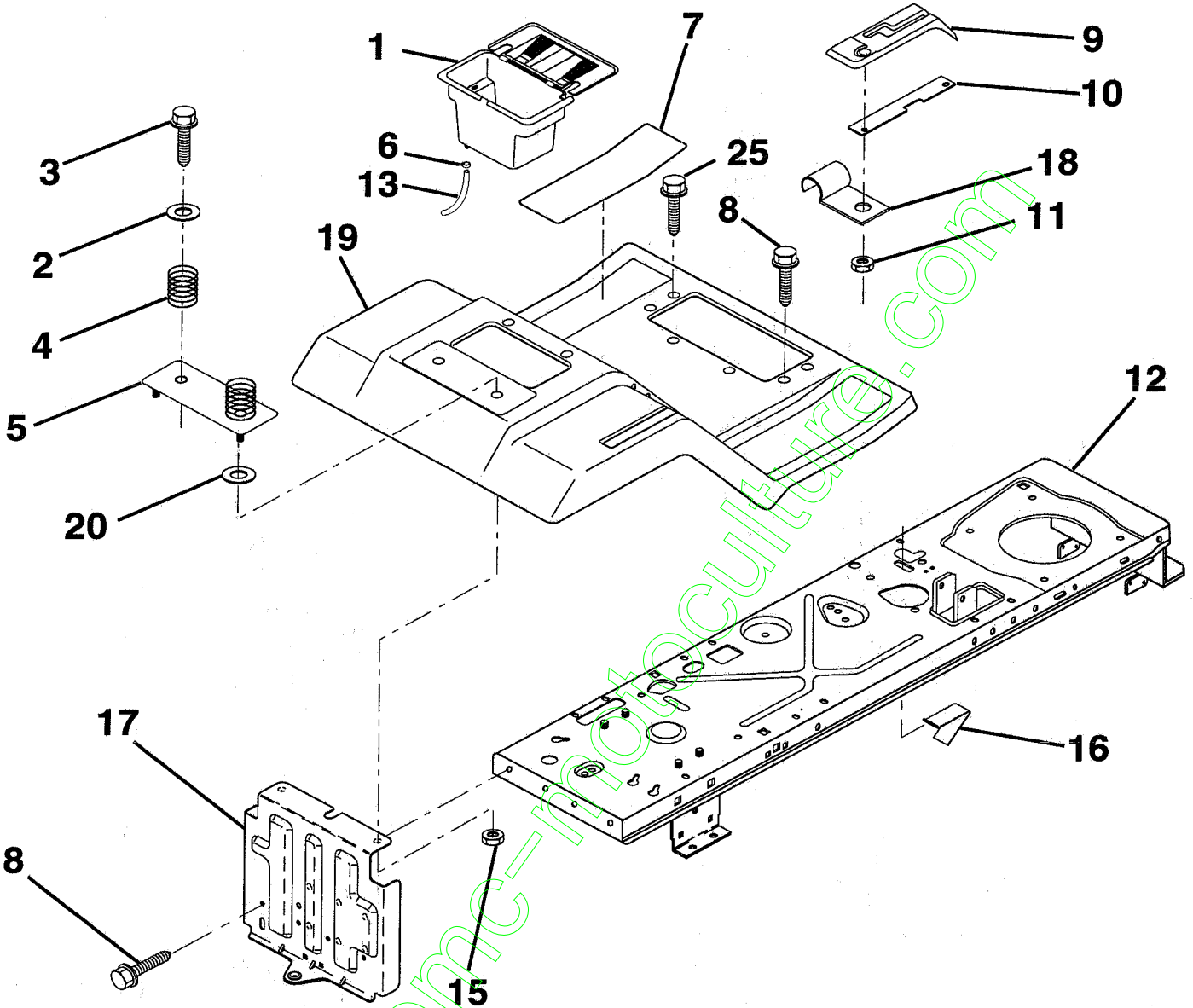

KEY NO.	PART NO.	DESCRIPTION
1	129965	Case, Battery
2	19132012	Washer, 13/32 x 1-1/4 x 12 Gauge
3	17490612	Screw, Hex Washer Head, Thd. Roll. 3/8-16 x 3/4
4	124181X	Spring, Compression, Seat
5	127115X505	Plate, Battery
6	109596X	Clamp, Hose
7	124144X	Pad, Footrest
8	17490512	Screw, Hex Washer Head, Thd. Roll. 5/16-18 x 3/4
9	126994X	Console, Shift Control
10	139783	Bar, Shift Lock

KEY NO.	PART NO.	DESCRIPTION
11	124346X	Nut, Self-Threading 3/16
12	145190	Chassis Assembly, Weldment
13	109238X	Tube, Battery Drain
15	73640400	Nut, Hex, Keps 1/4-20
16	141736	Switch, Actuator
17	140782	Drawbar
18	126470X	Clip, Insulated
19	140955X505	Fender/Footrest
20	19091413	Washer 9/32 x 7/8 x 13 Gauge
25	17190516	Scr.-Hx Wsh Thd Rol 5/16 - 18 x 1T

NOTE: All component dimensions given in U.S. inches.
1 inch = 25.4 mm.

HARDWARE SHOWN LARGER FOR EASIER IDENTIFICATION

REPAIR PARTS

TRACTOR -- MODEL NUMBER LM1236D

SEAT

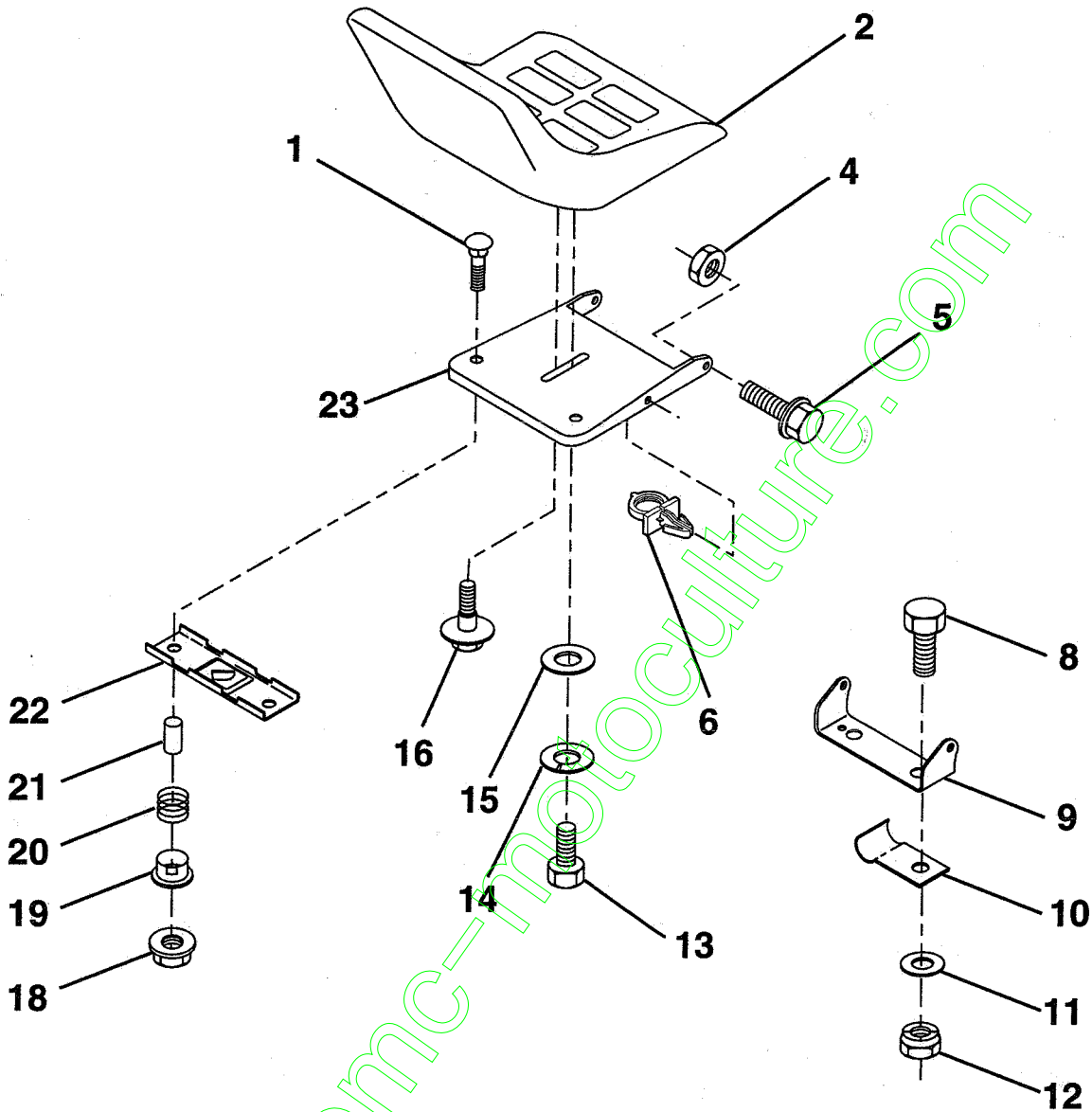

KEY NO.	PART NO.	DESCRIPTION
1	72050411	Bolt, Carriage 1/4-20 x 1-3/8
2	134647	Seat
4	73800500	Nut, Lock Hex W/Ins. 5/16-18
5	139888	Bolt, Shld. 5/16-18
6	145006	Clip, Push-In
8	74760616	Bolt, Hex, Fin 3/8-16 UNC x 3/4
9	140551	Bracket, Pivot, Seat
10	126471X	Clip, Insulated
11	19133210	Washer 13/32 x 2 x 10 Gauge
12	73800600	Nut, Lock Hex W/Wsh 3/8-16

KEY NO.	PART NO.	DESCRIPTION
13	74780814	Bolt, Fin Hex 1/2 - 13 x 7/8 Gr. 5
14	10040800	Washer Lock Hvy HLCL Spr. 1/2
15	19171912	Washer 17/32 x 13/16 x 12 Gauge
16	127018X	Bolt, Shoulder
18	123976X	Locknut, Hex, Large, Flange
19	121248X	Bushing, Snap
20	121250X	Spring, Compression
21	134300	Spacer, Split, Large .28 Id. x .96
22	121246X	Bracket, Switch, Mounting
23	140552	Pan, Seat

NOTE: All component dimensions given in U.S. inches.
1 inch = 25.4 mm.

HARDWARE SHOWN LARGER FOR EASIER IDENTIFICATION

REPAIR PARTS

TRACTOR - - MODEL NUMBER LM1236D

DASH

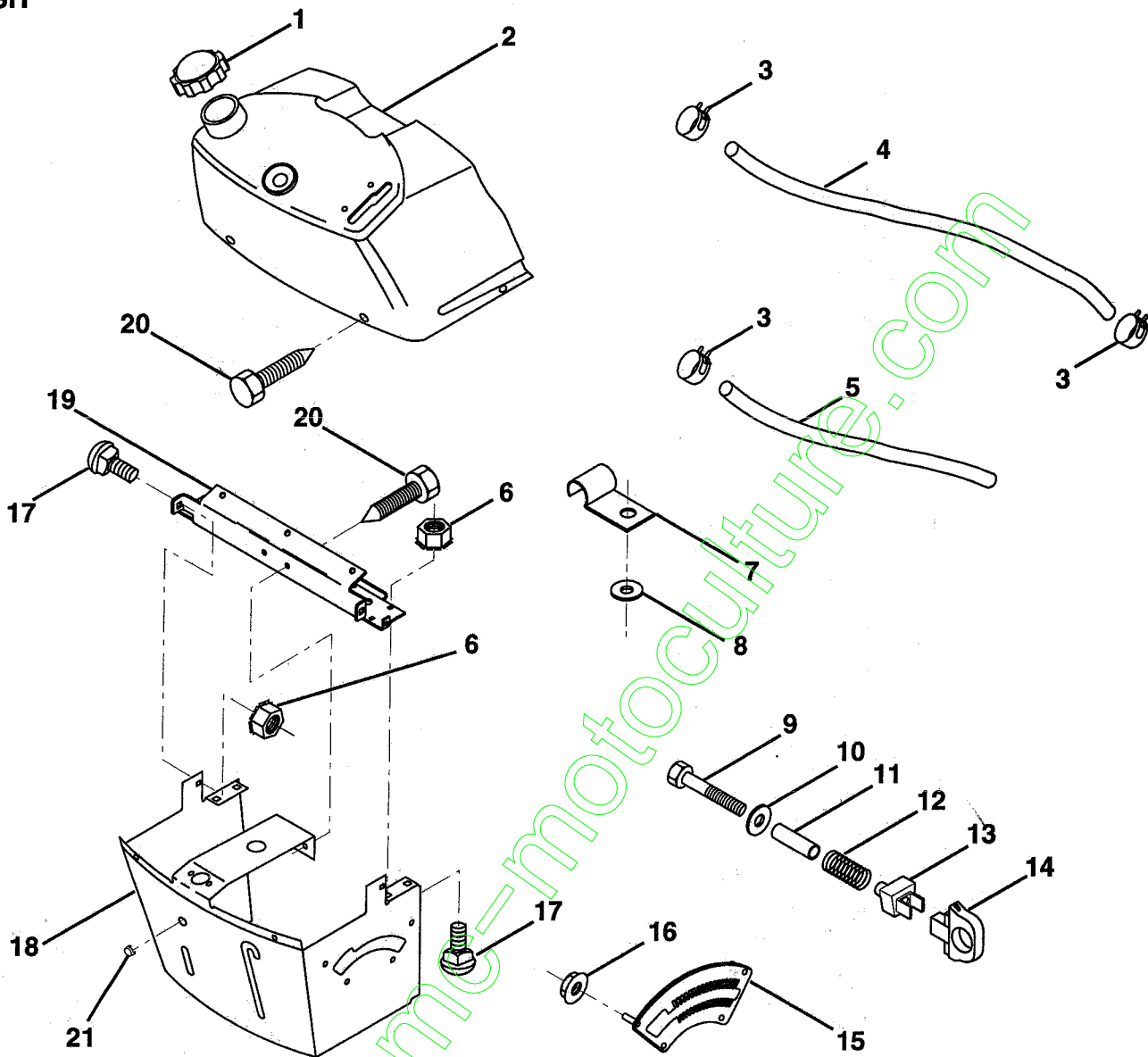

KEY NO.	PART NO.	DESCRIPTION
1	141523	Cap, Fuel
2	138393	Assembly, Dash & Fuel Tank
3	123487X	Clamp, Hose
4	8544R	Line, Fuel
5	8548R	Line, Fuel
6	73400400	Nut, Hex, Keps 1/4-20
7	2751R	Clip, Fuel Line
8	19091216	Washer 9/32 x 3/4 x 16 Gauge
9	74760428	Bolt, Hex, Fin. 1/4-20 x 1-3/4
10	19091413	Washer 11/32 x 11/16 x 16 Gauge
11	121249X	Spacer, Split

KEY NO.	PART NO.	DESCRIPTION
12	3720R	Spring
13	126450X	Clip, Height Adjustment
14	126115X	Knob, Height Stop
15	122023X	Adjustment, Quadrant Height
16	124346X	Nut, Self-Threading 3/16-18
17	72110404	Bolt, Carriage 1/4-20 x 1/2 Grade 5
18	130745	Support Assembly, Dash
19	134744	Brace, Cross
20	17060408	Screw, Tap 1/4-20 x 1/2
21	134014	Plug, Dome

NOTE: All component dimensions given in U.S. inches.
1 inch = 25.4 mm.

HARDWARE SHOWN LARGER FOR EASIER IDENTIFICATION

REPAIR PARTS

TRACTOR -- MODEL NUMBER LM1236D

STEERING WHEEL

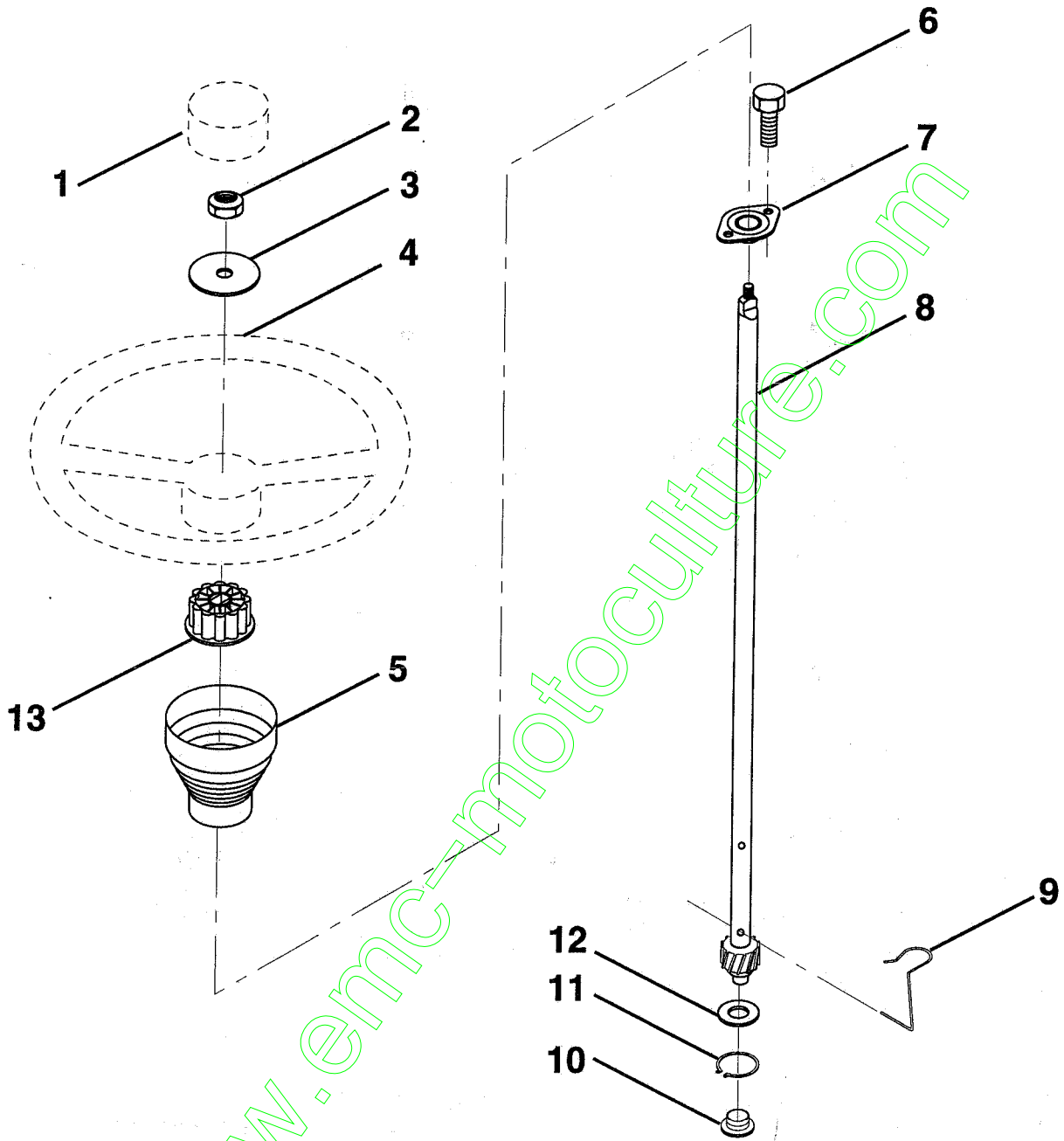

KEY NO.	PART NO.	DESCRIPTION
1	133742	Insert, Steering Wheel
2	7810H	Locknut 3/8-24 UNF
3	19133808	Washer 13/32 x 2-3/8 x 8 Ga.
4	133741	Wheel, Steering
5	121897X	Sleeve, Steering
6	17431008	Screw, Hex Self-Tapping #10-16 x 1/2
7	102803X	Bushing, Steering

KEY NO.	PART NO.	DESCRIPTION
8	123651X	Shaft, Steering
9	124210X	Clip, Steering
10	123438X	Bushing, Lower, Steering
11	12000045	Ring, Retaining
12	19211616	Washer 21/32 x 1 x 16 Ga.
13	104820X	Adaptor, Steering Wheel

NOTE: All component dimensions given in U.S. inches.
1 inch = 25.4 mm.

HARDWARE SHOWN LARGER FOR EASIER IDENTIFICATION

REPAIR PARTS

TRACTOR - - MODEL NUMBER LM1236D

SECTOR GEAR / AXLE SUPPORT

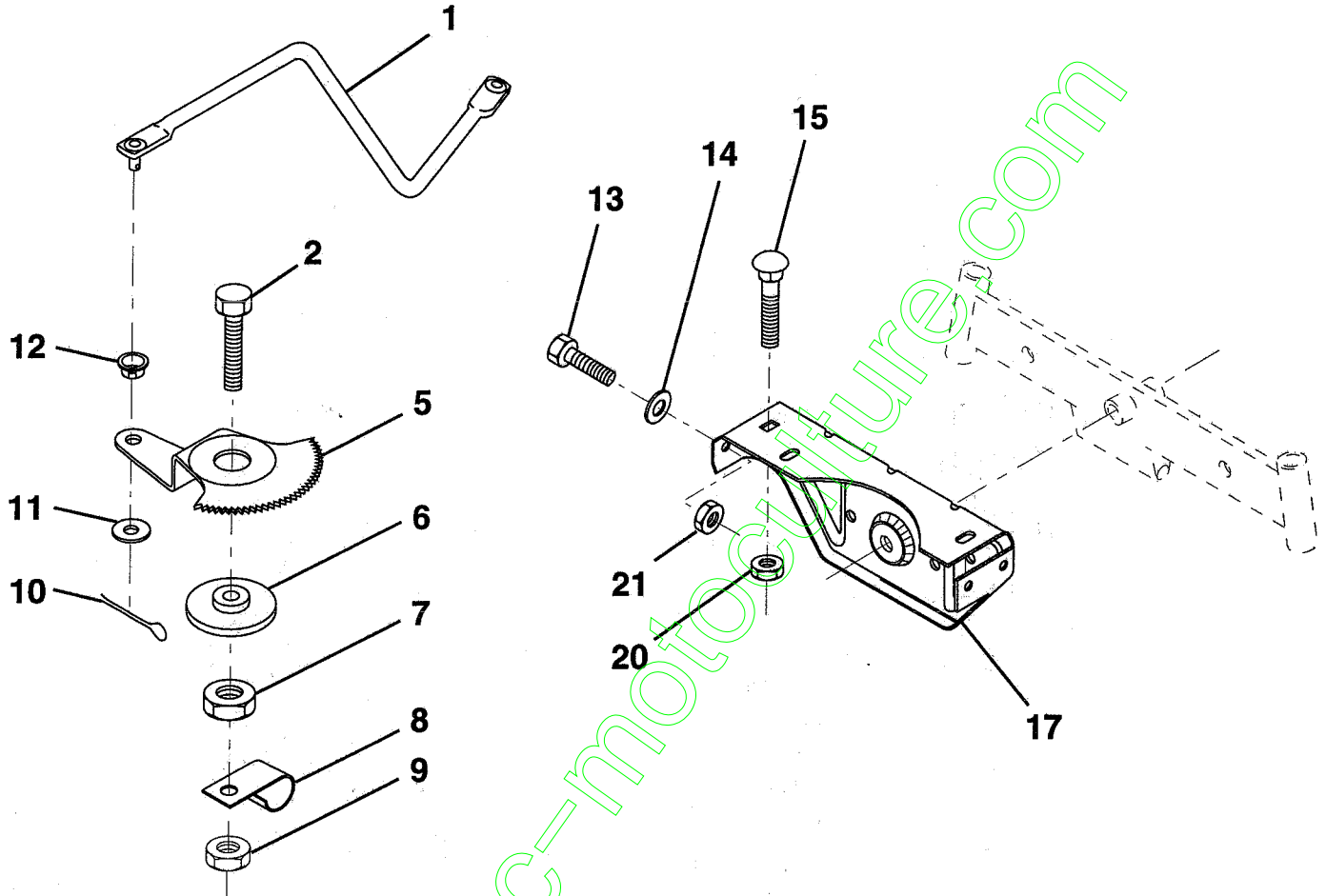

KEY NO.	PART NO.	DESCRIPTION
1	132566	Link, Drag
2	74780828	Bolt, Hex, Fin 1/2-13 x 1-3/4
5	121926X	Gear, Sector
6	121927X	Bushing
7	73030800	Nut, Heavy, Hex, Top Lock 1/2-13 UNC
8	126472X	Clip, Wire
9	73680800	Nut, Crownlock 1/2-13
10	76020412	Pin, Cotter 1/8 x 3/4
11	19131316	Washer 13/32 x 13/16 x 16 Ga.

KEY NO.	PART NO.	DESCRIPTION
12	126847X	Bushing
13	74760512	Bolt, Hex 5/16-18 x 3/4
14	19111416	Washer 11/32 x 7/8 x 16 Ga.
15	72110606	Bolt, Carriage 3/8-16 UNC x 3/4
17	137096	Support, Front Axle
20	73680600	Nut, Crownlock 3/8-16 UNC
21	73680500	Nut, Crownlock 5/16-18

NOTE: All component dimensions given in U.S. inches.
1 inch = 25.4 mm.

HARDWARE SHOWN LARGER FOR EASIER IDENTIFICATION

REPAIR PARTS

TRACTOR - - MODEL NUMBER LM1236D

FRONT AXLE

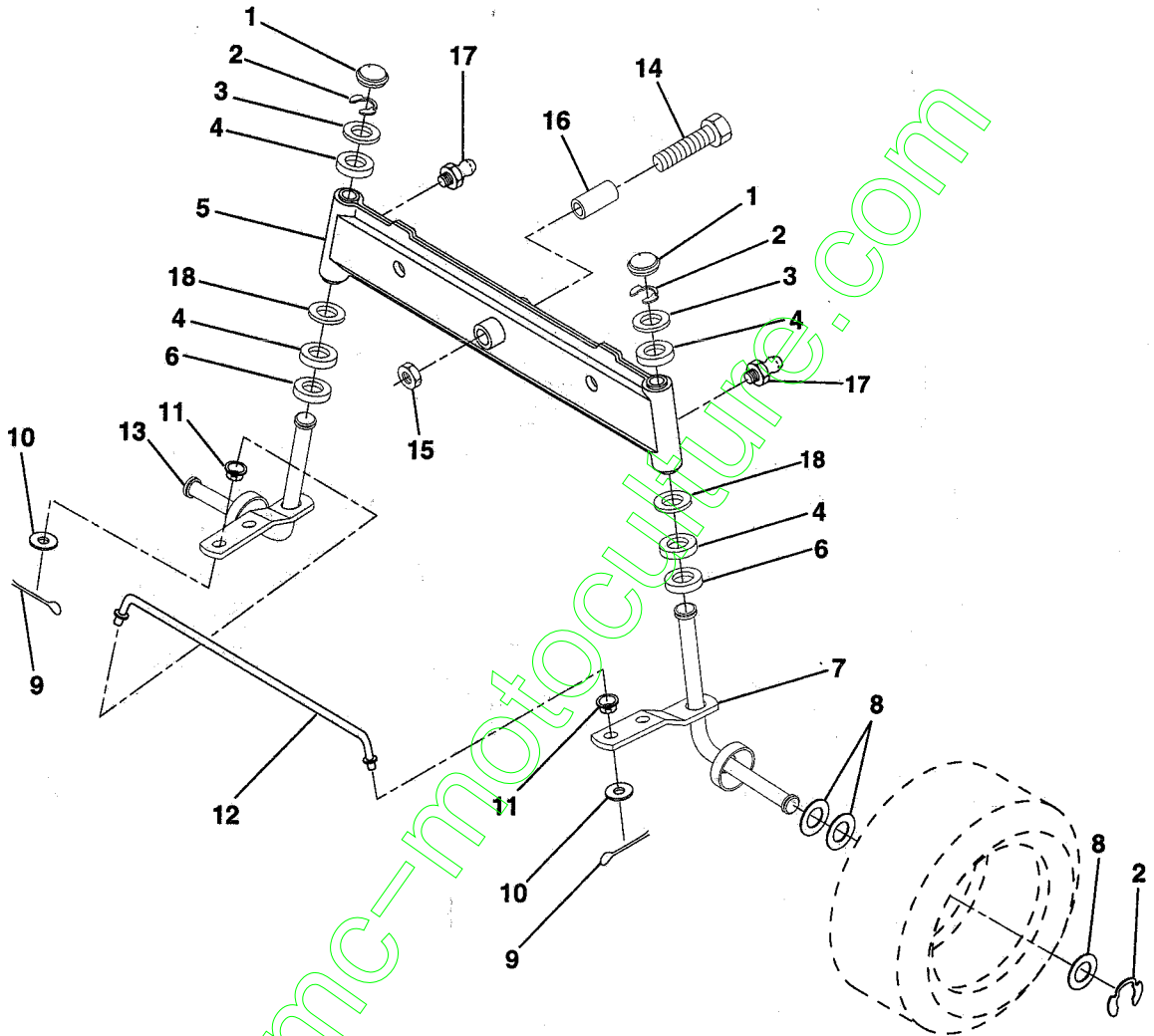

KEY NO.	PART NO.	DESCRIPTION
1	121232X	Cap, Spindle
2	1200029	Ring, Klip
3	121748X	Washer 25/32 x 1-5/8 x 16 Gauge
4	3366R	Bearing
5	142033	Axle, Front
6	6266H	Bearing, Thrust
7	137062	Spindle Assembly, R.H.
8	121749X	Washer 25/32 x 1-1/4 x 16 Gauge
9	76020412	Pin, Cotter 1/8 x 3/4
10	19131316	Washer 13/32 x 13/16 x 16 Gauge

KEY NO.	PART NO.	DESCRIPTION
11	126847X	Bushing
12	130465	Rod, Tie
13	137061	Spindle Assembly, L.H.
14	74011056	Bolt, Hex 5/8-11 x 3-1/2
15	73901000	Nut, Lock Flange 5/8-11
16	110438X	Spacer
17	6855M	Fitting, Grease
18	19272016	Washer 27/32 x 1-1/4 x 16 Ga.

NOTE: All component dimensions given in U.S. inches.
1 inch = 25.4 mm.

HARDWARE SHOWN LARGER FOR EASIER IDENTIFICATION

REPAIR PARTS

TRACTOR -- MODEL NUMBER LM1236D

GROUND DRIVE

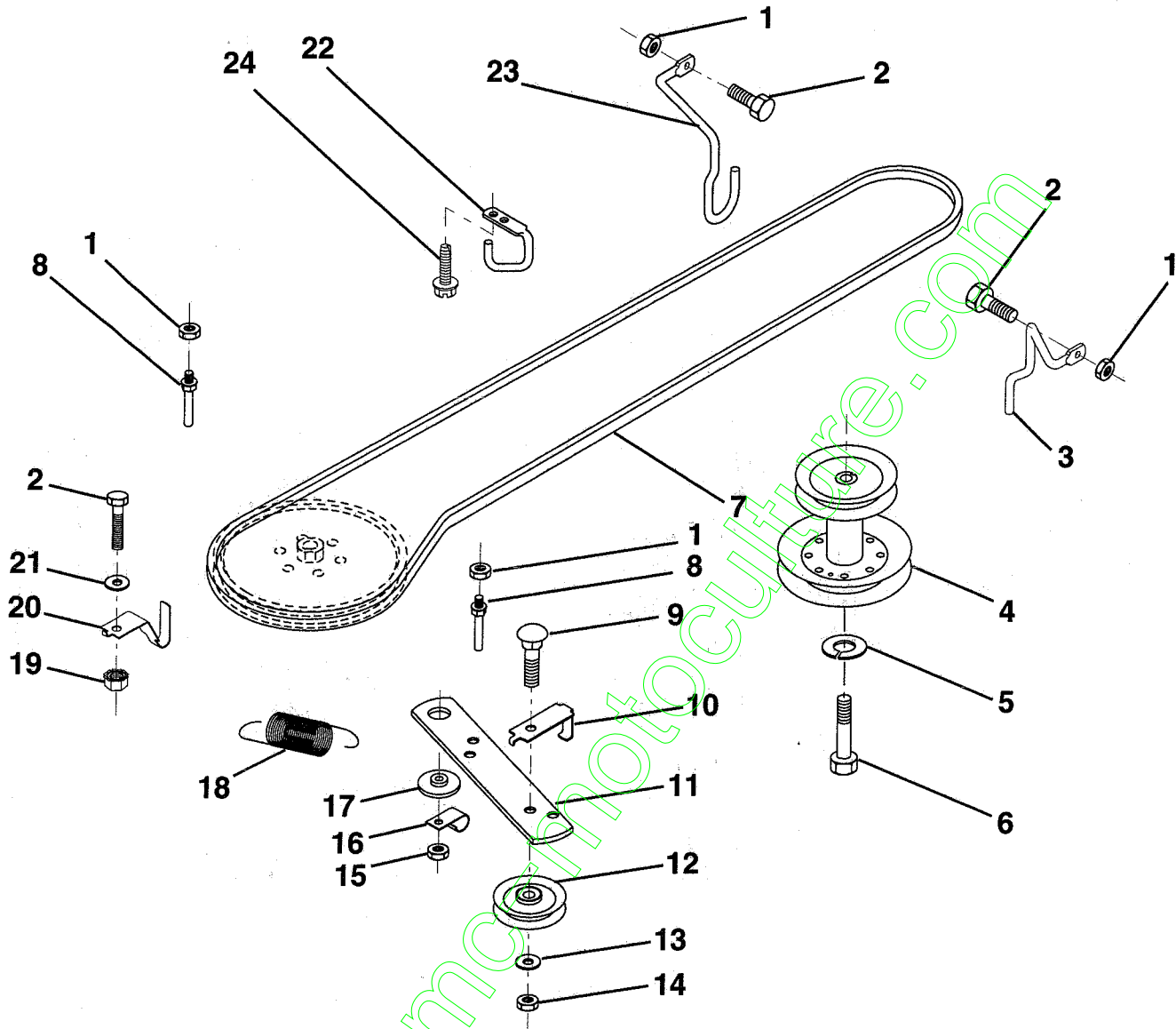

KEY NO.	PART NO.	DESCRIPTION	KEY NO.	PART NO.	DESCRIPTION
1	73680500	Nut, Lock Hex W/Ins 5/16-18	13	19131316	Washer 13/32 x 13/16 x 16 Gauge
2	74760512	Bolt, Hex 5/16-18 UNC x 3/4	14	73930600	Nut, Centerlock 3/8-16 UNC
3	141342	Keeper, Mower Drive Belt, Engine, R.H.	15	73680600	Crownlock, Nut 3/8-16
4	138029	Pulley, Engine	16	126471X	Clip, Insulated
5	10040700	Washer, Lock, Heavy Helical Spring 7/16	17	122052X	Spacer, Retainer
6	71170744	Bolt, Hex, 7/16-20 x 2-3/4 Grade 5	18	131459	Spring, Extension
7	124525X	Traction, V-Belt Drive	19	73510500	Nut, Keps 5/16-18 UNC
8	123405X	Keeper, T/A Ground Drive Belt	20	139919	Keeper, T/A Ground Drive Belt
9	72140612	Bolt, Carriage 3/8-16 UNC x 1-1/2	21	19111016	Washer 11/32 x 5/8 x 16 Gauge
10	123396X	Keeper, Ground Drive Belt, Idler	22	123404X	Keeper, Ground Drive Belt, Frame
11	140911	Arm, Ground Drive Clutch	23	140916	Keeper, Mower Drive Belt, L.H.
12	123674X	Idler, Flat	24	17720408	Screw, Thd, Cut, 1/4-20 X 1/2.

NOTE: All component dimensions given in U.S. inches.
1 inch = 25.4 mm

HARDWARE SHOWN LARGER FOR EASIER IDENTIFICATION

REPAIR PARTS

TRACTOR -- MODEL NUMBER LM1236D

TRANSAXLE

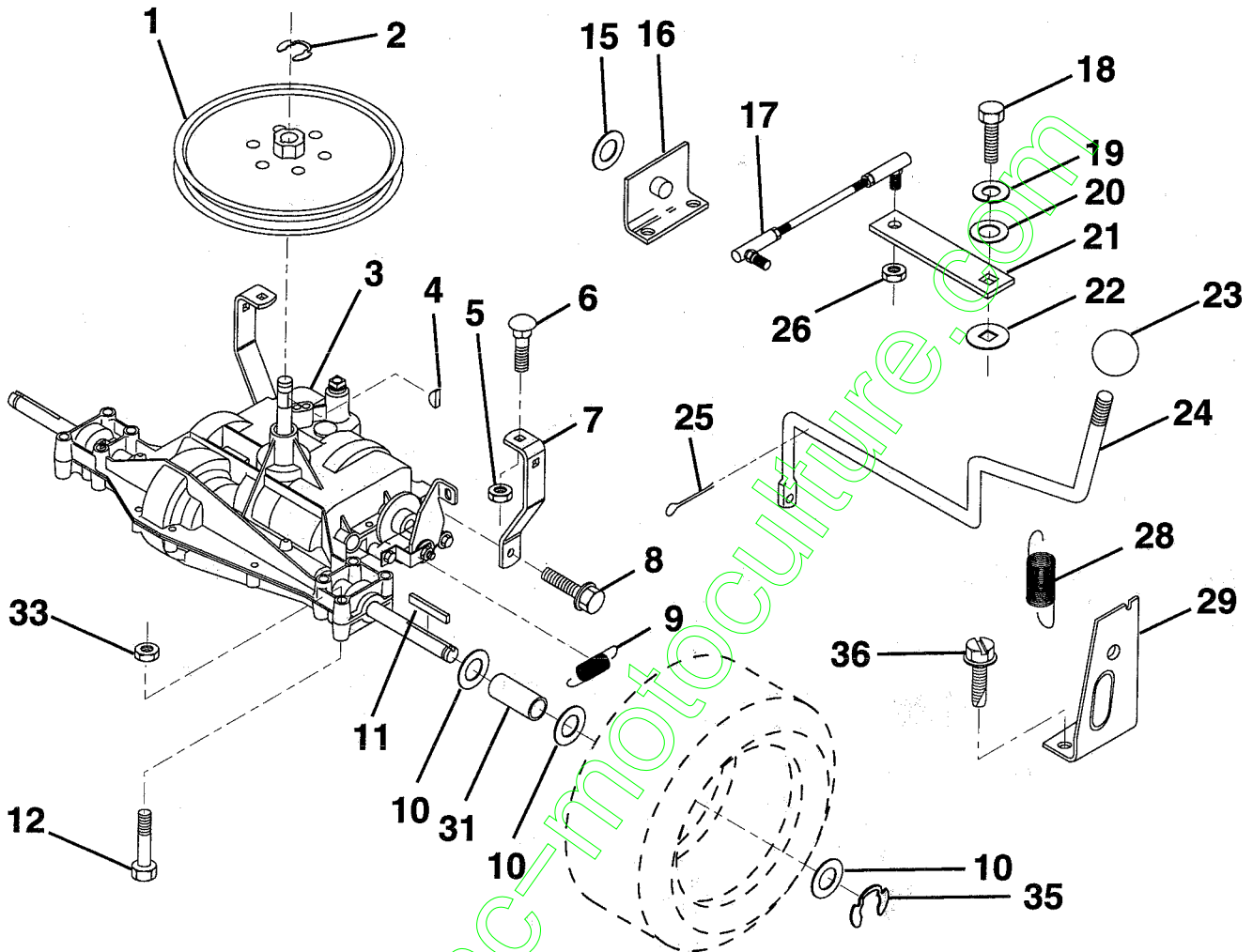

KEY NO.	PART NO.	DESCRIPTION
1	123385X	Pulley
2	1200028	Ring, Retainer
3	142602	Transaxle Model Number 4360-78
4	2228M	Key, Woodruff #9
5	73680500	Nut, Lock Hex 5/16-18
6	72140506	Bolt, Carriage 5/16-18 UNC x 3/4
7	123378X	Strap, Torque
8	17490512	Screw 5/16-18 x 3/4
9	146682	Spring, Brake
10	121749X	Washer 25/32 x 1-1/4 x 16 Gauge
11	123583X	Key, Square
12	74760644	Bolt Fin Hex 5/16-18 x 2-1/2
15	19171616	Washer 17/32 x 16 Ga.
16	124600X	Support, Handle Shift
17	123632X	Link, Shift
18	74550412	Bolt, Hex, Fin. 1/4-28 UNF x 3/4 Grade 8

KEY NO.	PART NO.	DESCRIPTION
19	10040400	Washer, Lock 1/4
20	19091210	Washer 9/32 x 3/4 x 10 Gauge
21	123484X	Arm, Shift
22	105701X	Washer, Shift Plate
23	106933X	Knob, Deluxe
24	128215	Rod, Shift
25	76020416	Pin, Cotter 1/8 x 1
26	73810500	Nut, Hex, Nylon 5/16-24 UNF
28	128085	Spring, Extension
29	128084	Support, Handle, Shift, R.H.
31	109502X	Spacer, Split
33	73680600	Nut, Crownlock 3/8-16
35	12000001	E-Ring
36	17720408	Screw, Thd. Cut. 1/4-20 X 1/2

NOTE: All component dimensions given in U.S. inches.
1 inch = 25.4 mm.

HARDWARE SHOWN LARGER FOR EASIER IDENTIFICATION

REPAIR PARTS

TRACTOR - - MODEL NUMBER LM1236D

ENGINE / THROTTLE

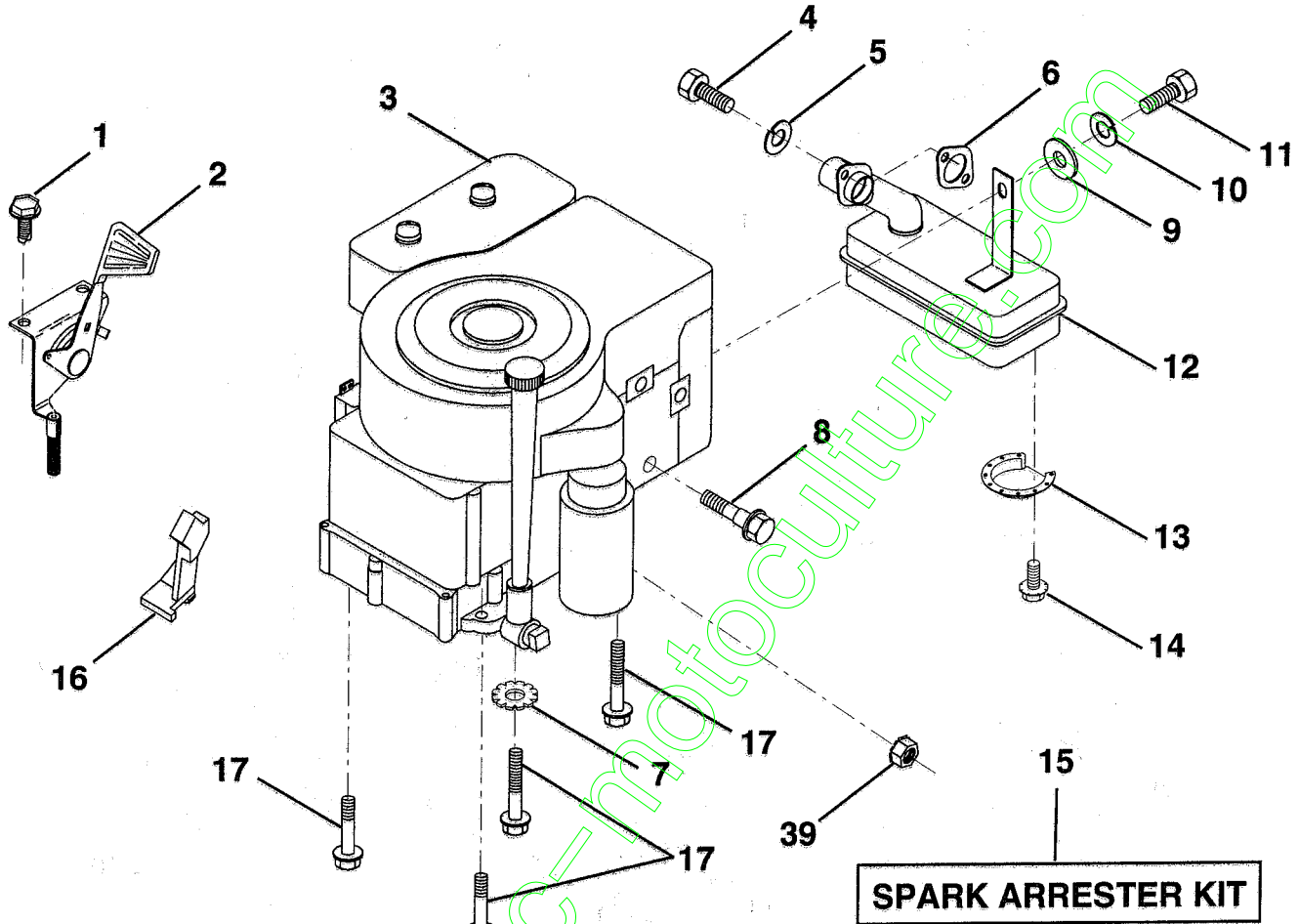

KEY NO.	PART NO.	DESCRIPTION
1	17060408	Screw, Hex, Thread Cutting 1/4-20 x 1/2
2	133025	Control, Throttle
3	145296	Engine, B&S, 12 HP, model #282707
4	71070512	Screw, Hex Hd
5	10040500	Washer, Lock, Heavy Helical Spring 5/16
6	125593X	Gasket, Exhaust
7	11050600	Washer lock ext tooth
8	121094X	Bolt, Shoulder 5/16 UNC
9	19101216	Washer 5/16 x 3/4 x 16 Gauge

KEY NO.	PART NO.	DESCRIPTION
10	10040400	Washer, Lock, Heavy Helical Spring 1/4
11	74760412	Bolt, Hex, Fin 1/4-20 x 3/4
12	137437	Muffler
13	101326L	Deflector Muffler
14	17030808	Screw Spiderlock
15	137180	Kit, Spark Arrester (Optional)
16	127951	Stop, Choke
17	17490624	Screw, Hex Washer Head, Thd. Roll. 3/8-16 x 1-1/2
39	73510400	Nut, Keps, Hex, 1/4-20

NOTE: All component dimensions given in U.S. inches.
1 inch = 25.4 mm

HARDWARE SHOWN LARGER FOR EASIER IDENTIFICATION

REPAIR PARTS

TRACTOR - - MODEL NUMBER LM1236D

BRAKE/REAR MOWER LIFT ASSEMBLY

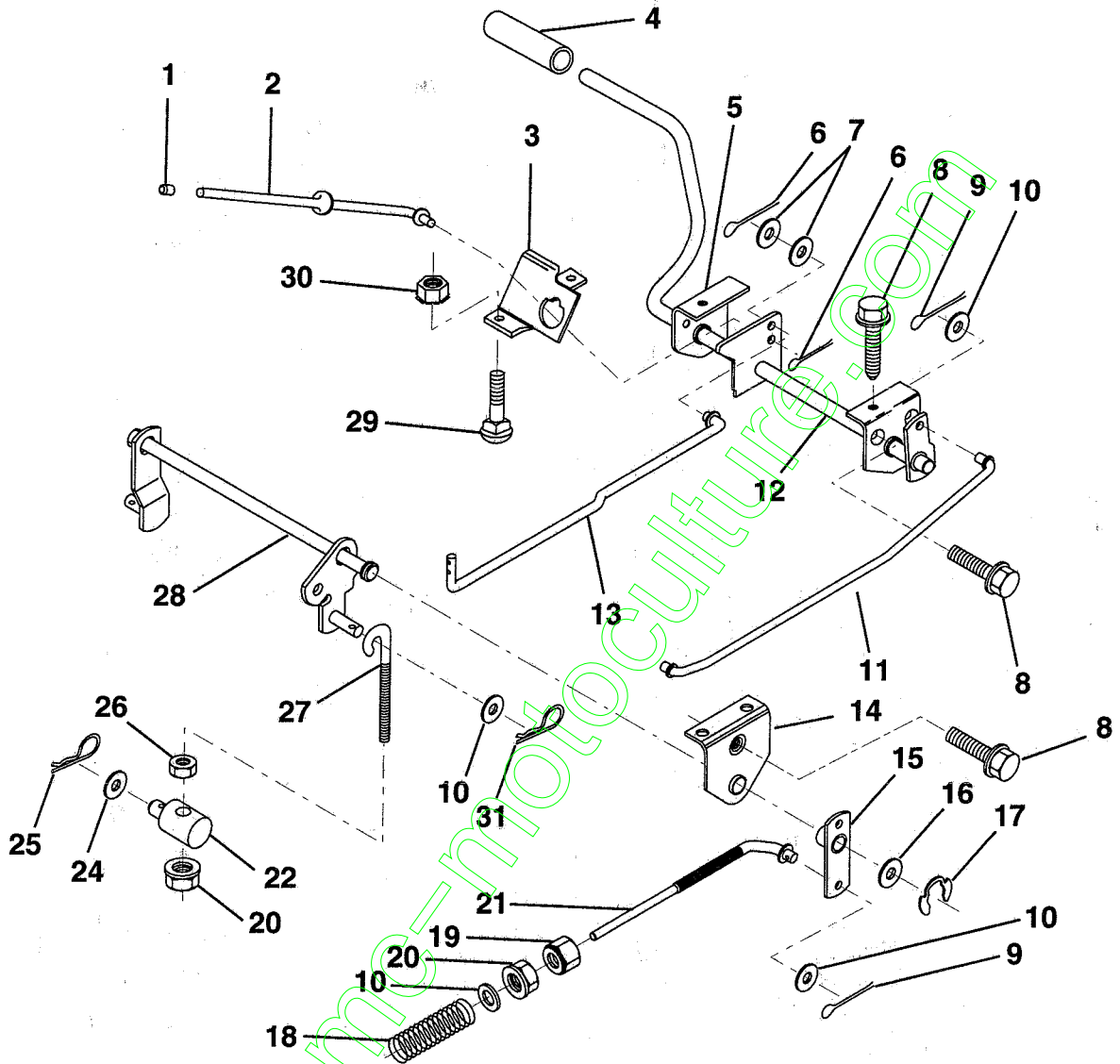

KEY PART
NO. NO.

DESCRIPTION

1	71673	Cap, Parking Brake
2	123436X	Rod, Parking Brake
3	123437X	Bracket, Parking Brake
4	8156H	Cover, Pedal
5	122504X	Bracket, Pedal, Clutch LH
6	76020312	Pin, Cotter 3/32 x 3/4
7	19131016	Washer 13/32 x 5/8 x 16 Gauge
8	17490508	Screw, Hex, Thd. Roll. 5/16-18 x 1/2
9	76020412	Pin, Cotter 1/8 x 3/4
10	19131316	Washer 13/32 x 13/16 x 16 Gauge
11	123543X	Rod, Front Brake
12	139933	Assembly, Clutch/Brake Pedal
13	123394X	Rod, Clutch
14	121978X	Bracket, Lift, Shaft
15	133332	Assembly, Brake, Pivot, Arm

KEY PART
NO. NO.

DESCRIPTION

16	19251816	Washer 25/32 x 1-1/8 x 16 Gauge
17	12000034	Ring, Klip
18	106888X	Spring, Brake Rod
19	73350600	Nut, Hex, Jam 3/8-16 UNC
20	73680600	Crownlock, Nut 3/8-16
21	131460	Rod, Rear Brake
22	144585	Trunnion, Lift
24	19132012	Washer 13/32 x 1-1/4 x 12 Gauge
25	4921H	Spring, Retainer
26	73930600	Nut, Centerlock 3/8-16 UNC
27	127369	Link, Threaded
28	140776	Assembly, Rear Mower Lift
29	72110506	Bolt, Carriage 5/16-18 UNC x 3/4
30	73510500	Nut, Keps 5/16-18 UNC
31	3146R	Retainer spring

NOTE: All component dimensions given in U.S. inches.
1 inch = 25.4 mm.

HARDWARE SHOWN LARGER FOR EASIER IDENTIFICATION

REPAIR PARTS

TRACTOR -- MODEL NUMBER LM1236D

MOWER LIFT LEVER

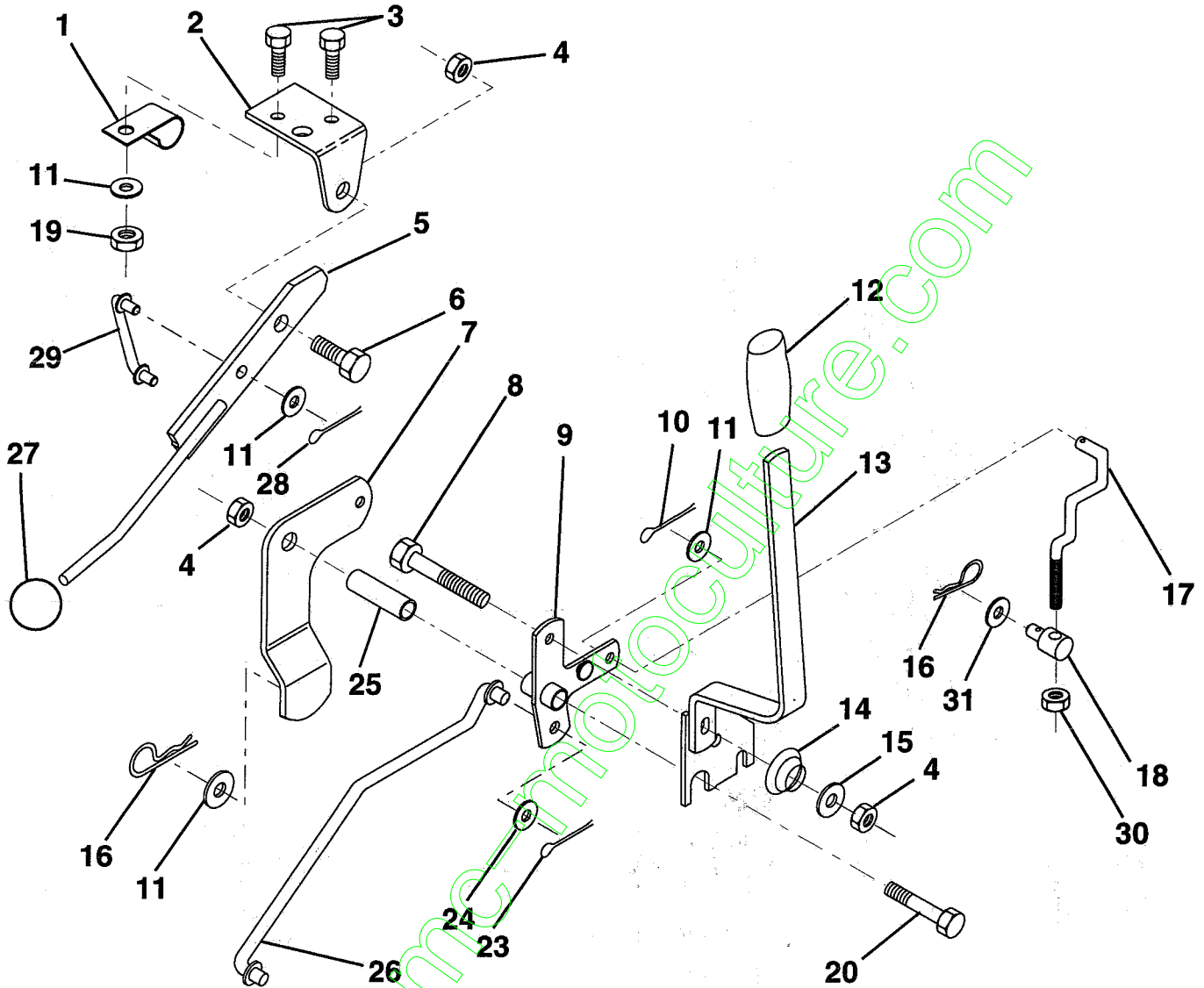

KEY NO.	PART NO.	DESCRIPTION
1	126470X	Clip, Insulated
2	122018X	Bracket, Mower Clutch
3	71110408	Bolt, Hex, Fin 1/4-20 UNC x 1/2 Grade 5
4	73680600	Nut, Lock Hex W/Wsh 3/8-16
5	145187	Assembly, Clutch Lever
6	106451X	Bolt, Shoulder
7	135371	Assembly, Mower Clutch Arm
8	74760636	Bolt, Hex 3/8-16 UNC x 2-1/4
9	121930X	Assembly, Bellcrank, Lift
10	76020412	Pin, Cotter 1/8 x 3/4
11	19131316	Washer 13/32 x 13/16 x 16 Gauge
12	131861	Sleeve, Handle
13	139352	Assembly, Lift Handle
14	123496X	Spring, Compression
15	19131212	Washer 13/32 x 3/4 x 12 Gauge

KEY NO.	PART NO.	DESCRIPTION
16	4921H	Retainer, Spring
17	127359	Link, Front Lift
18	142028	Trunnion, Threaded 3/8-16
19	73680400	Nut, Crownlock 1/4-20
20	74760644	Bolt, Hex, Fin. 3/8-16 UNC x 2-3/4
23	76020416	Pin, Cotter 1/8 x 1
24	19171616	Washer 17/32 x 1 x 16 Gauge
25	121933X	Tube, Spacer
26	141470	Rod, Mower Lift
27	106932X	Knob, Rd
28	76020312	Pin, Cotter 3/32 x 3/4
29	131655	Link, Mower Clutch
30	73350600	Nut, Hex Jam 3/8-16
31	19132012	Washer 13/32 x 1-1/4 x 12 Ga.

NOTE: All component dimensions given in U.S. inches.
1 inch = 25.4 mm.

HARDWARE SHOWN LARGER FOR EASIER IDENTIFICATION

REPAIR PARTS

TRACTOR -- MODEL NUMBER LM1236D

MOWER DECK

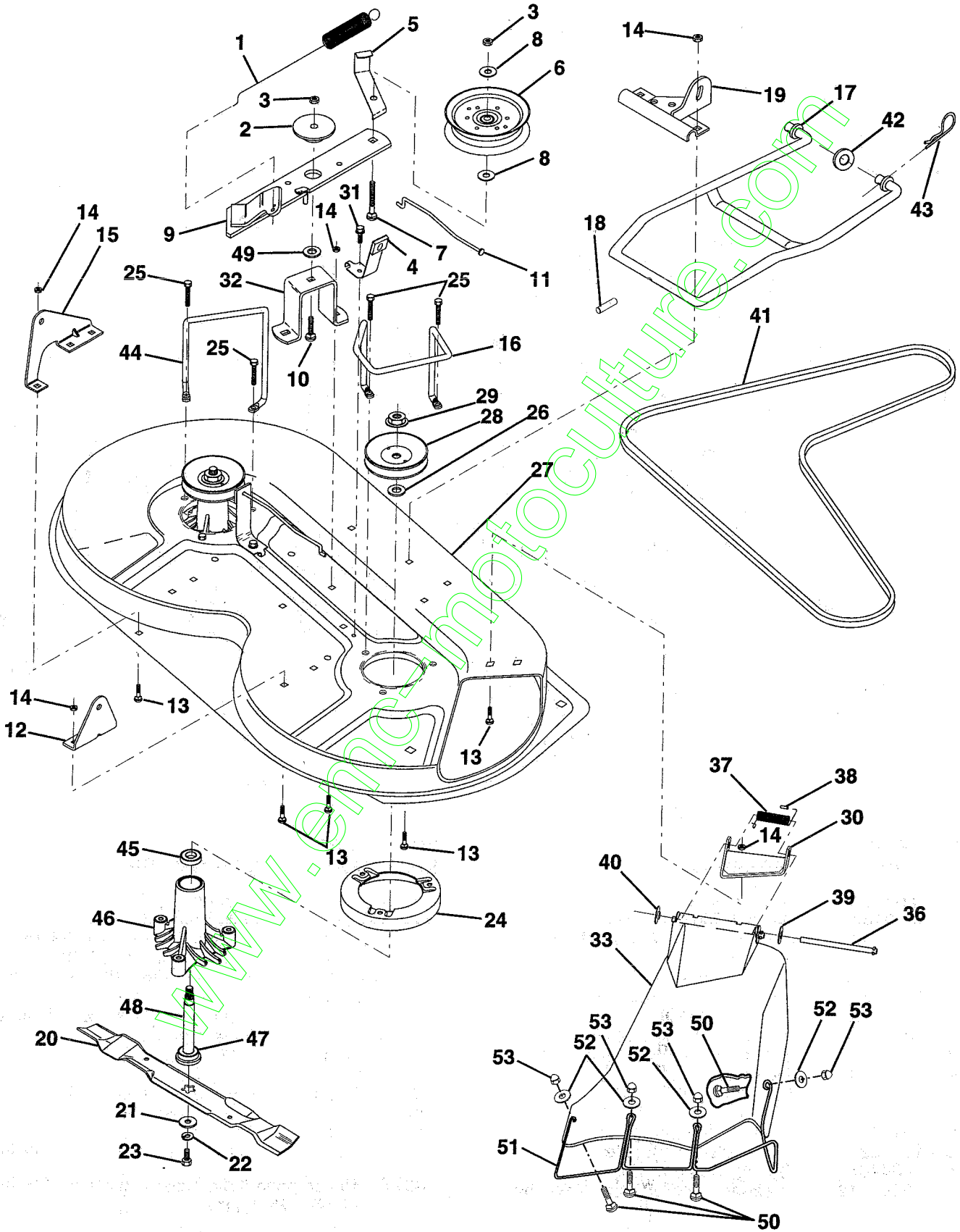

REPAIR PARTS

TRACTOR - - MODEL NUMBER LM1236D

MOWER DECK

KEY NO.	PART NO.	DESCRIPTION	KEY NO.	PART NO.	DESCRIPTION
1	140064	Spring, Mower Clutch	30	136631	Bracket, Deflector
2	122052X	Spacer, Retainer	31	17490508	Screw, Hex Washer Head, Thd. Roll. 5/16-18 x 1/2
3	73680600	Nut, Lock Hex W/Wsh 3/8-16	32	122051X	Arm, Support Idler, Mower
4	130840	Assembly, Brake	33	139083	Shield, Deflector
5	131251	Guide, Belt Idler	36	121980X	Rod, Hinge
6	121316X	Idler, Flat	37	123713X	Spring, Torsion Deflector
7	72110616	Bolt, Carriage 3/8-16 x 2 Grade 5	38	105304X	Cap, Sleeve
8	19131410	Washer 13/32 x 7/8 x 10 Gauge	39	19111016	Washer 11/32 x 5/8 x 16 Gauge
9	127744	Assembly, Mower Idler Arm	40	110452X	Nut, Push
10	72140610	Bolt, Carriage 3/8-16 x 1-1/4	41	131264	V-Belt
11	130841	Rod, Brake	42	19171616	Washer 11/32 x 5/8 x 16 Gauge
12	127356	Bracket, Rear Lift, R.H.	43	3146R	Clip, Hairpin
13	72140506	Bolt, Carriage 5/16-18 UNC x 5/8	44	140608	Keeper, L.H.
14	73680500	Nut, Lock Hex W/Ins 5/16-18	45	110485X	Bearing
15	127357	Bracket, Rear Lift, L.H.	46	128774	Housing, Mandrel, Vented
16	140093	Keeper, R.H.	47	129895	Bearing
17	128508	Stabilizer, Mower Link	48	137645	Shaft, Mandrel (Includes Key Number 47)
18	128511	Pin, Drive	49	133943	Washer, Hardened
19	127380	Bracket, Stabilizer Link	50	M720305016	Bolt, Rd, Hd, SQ, NK, M5X0.8 X 16
20	138496	Blade, Mwr. 36" High Lift	51	136383	Guard, DFTR, MWR, 36" TUV
21	140296	Washer, Hard Blade Mower Vented	52	19070718	Washer
22	10030600	Washer, Lock, Heavy 3/8	53	M730705000	Nut, Acorn M5 X 0.8
23	850857	Bolt 3/8-24 x 1-1/4 Grade 8	--	130794	Mandrel Assembly (Includes Key Numbers 21-23, 26, 29 and 45-48)
24	140329	Stripper	--	144973	Deck 36 HP. LR
25	138776	Screw, Thdrol. Hex Hd.			
26	129963	Washer .150 Thick			
27	129983	Housing, Mower			
28	129207	Pulley, Mandrel			
29	137266	Nut, Flangelock 9/16			

NOTE: All component dimensions given in U.S. inches.
1 inch = 25.4 mm.

HARDWARE SHOWN LARGER FOR EASIER IDENTIFICATION

REPAIR PARTS

TRACTOR - - MODEL NUMBER LM1236D

DANA TRANSAXLE - MODEL NUMBER 4360-78

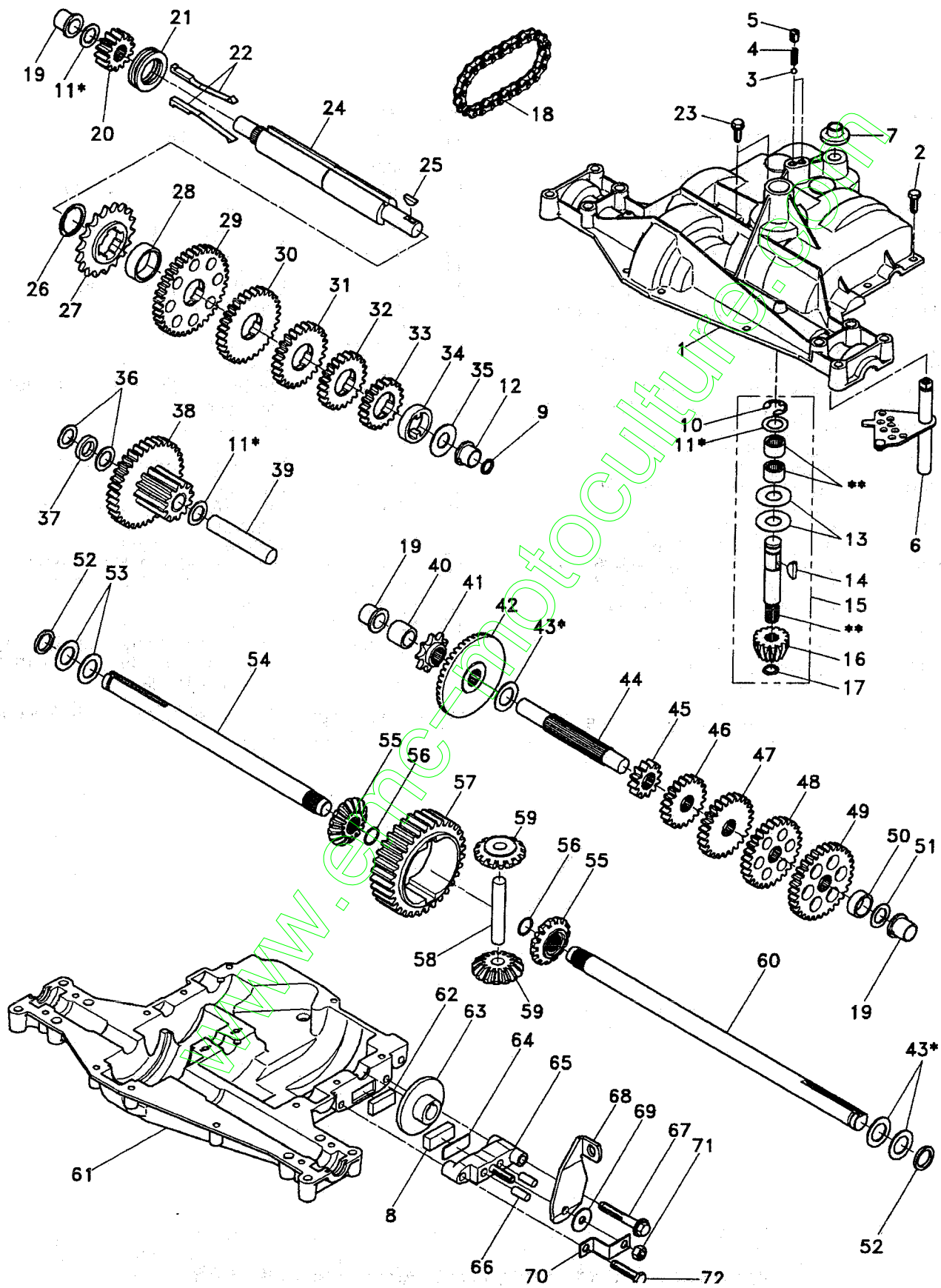

REPAIR PARTS

TRACTOR - - MODEL NUMBER LM1236D

DANA TRANSAXLE - MODEL NUMBER 4360-78

NO. DE RÉF.	NO. DE PIÈCE	DESCRIPTION	NO. DE RÉF.	NO. DE PIÈCE	DESCRIPTION
1	142671	Boîtier supérieur	40	120472X	Entretoise 0,635 x 0,875 x 0,755
2	2274J	Vis taraudée 1/4-20 x 0,734	41	105928X	Pignon à 9 dents
3	134400	Bille de détente	42	110084X	Engrenage en biseau à 42 dents
4	105904X	Ressort de détente	43	134394	* Ensemble du jeu d'arbre de cale 0,750
5	105905X	Vis de pression	44	120473X	Arbre d'entraînement
6	138235	Jeu de l'ensemble de changement de vitesse	45	142678	Engrenage droit à 12 dents
7	134399	Manchon de changement de vitesse	46	120407X	Engrenage droit à 20 dents
8	120951X	Palet de friction	47	106589X	Engrenage droit à 25 dents
9	143045	Bague d'étanchéité	48	120408X	Engrenage droit à 28 dents
10	142672	Bague de fermeture	49	105937X	Engrenage droit à 31 dents
11	134793	* Ensemble du jeu d'arbre de cale 0,625	50	105936X	Entretoise 0,781 x 1,00 x 0,375
12	143051	Palier à bride	51	2226J	Rondelle plate 0,632 x 1,00 x 0,060
13	120415X	Rondelle plate 0,632 x 1,38 x 0,046	52	134401	Rondelle de Neoprene
14	142674	Clavette-disque no. 9	53	2264J	Rondelle plate 0,758 x 1,25 x 0,031
15	138234	Ensemble du jeu d'arbre d'entrée	54	120474X	Essieu C.G.
16	110078X	Pignon en biseau à 14 dents	55	110081X	Engrenage à onglet à 15 dents
17	105909X	Bague de fermeture	56	105941X	Bague de fermeture
18	105910X	Chaîne de pas de 24	57	110071X	Engrenage droit à 32 dents
19	105911X	Palier à bride	58	120952X	Arbre transversal
20	142675	Engrenage droit à 14 dents	59	110082X	Engrenage à onglet à 15 dents
21	138246	Collet d'embrayage	60	120475X	Essieu C.D.
22	138236	Ensemble du jeu des clés d'embrayage	61	142680	Boîtier inférieur
23	134791	Vis taraudée avec le matériau d'étanchéité	62	120961X	Palet de friction
24	142676	Arbre intermédiaire	63	7294J	Disque à frein
25	2244J	Clavette-disque no. 61	64	108989X	Entretoise
26	105916X	Bague de fermeture	65	120953X	Mâchoire de frein
27	120470X	Pignon à 18 dents	66	120954X	Cheville
28	110070X	Entretoise	67	134799	Vis taraudée 5/16-18 x 2,25
29	142677	Engrenage droit à 37 dents	68	138244	Levier de commande
30	120405X	Engrenage droit à 30 dents	69	108996X	Rondelle plate 0,321 x 1,00 x 0,055
31	108980X	Engrenage droit à 25 dents	70	120956X	Support d'antirotation
32	120406X	Engrenage droit à 22 dents	71	73810500	Ecrou frein 5/16-24
33	134796	Engrenage droit à 19 dents	72	106596X	Vis taraudée 5/16-18 x 1,44
34	134797	Entretoise 1,133 x 1,50 x 0,375	73	120416X	Graisse
35	105925X	Rondelle plate 0,640 x 1,37 x 0,061			
36	2232J	Rondelle plate 0,632 x 1,00 x 0,026			
37	108978X	Entretoise 0,630 x 1,00 x 0,169			
38	110079X	Ensemble d'engrenage;			
39	124639X	Combinaison des 12 dents et 35 dents			
		Arbre du galet-tendeur			

* Utiliser dans les différentes combinaisons pour maintenir des écarterments appropriés.

** Commander le no. de réf. 15.

REMARQUE: Toutes les dimensions de composant sont données en pouces E.-U. 1 pouce = 25,4 mm.

REPAIR PARTS

TRACTOR -- MODEL NUMBER LM1236D

DECALS

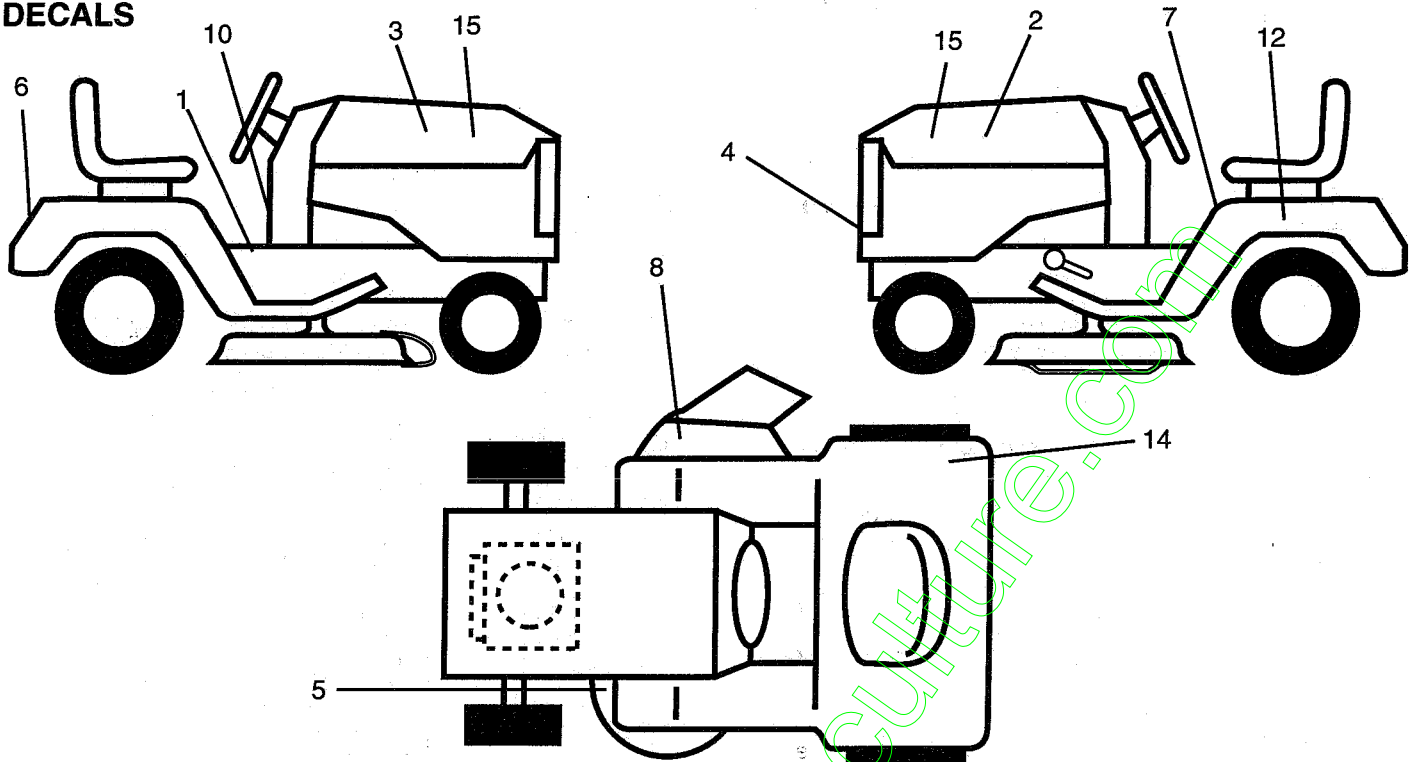

KEY NO.	PART NO.	DESCRIPTION
1	145545	Decal, Inst. Oper. Symbols E/F
2	141744	Decal, Stripe, Hood, L.H.
3	141743	Decal, Stripe, Hood, R.H.
4	132627	Decal, Grill
5	136830	Decal, V-Belt Sch.
6	132628	Decal, Fender
7	145498	Decal, Read Owner's Manual Symbol
8	145494	Decal, Mower Cut Finger Symbol

KEY NO.	PART NO.	DESCRIPTION
10	145437	Deca. Europe. Stand. CE
12	145005	Decal, Battery, Dan
14	125690X	Decal 100 DbA
15	136082	Decal, Hood Insert
--	147061	Manual, Operator's (English)
--	146974	Manual, Operator's (French)
--	147485	Manual, Repair Parts (Eng/Fr)
Available accessories are not included with your tractor:		
--	CE36	Rear Bagger
--	MP36	Mulcher Kit

TIRES & WHEELS

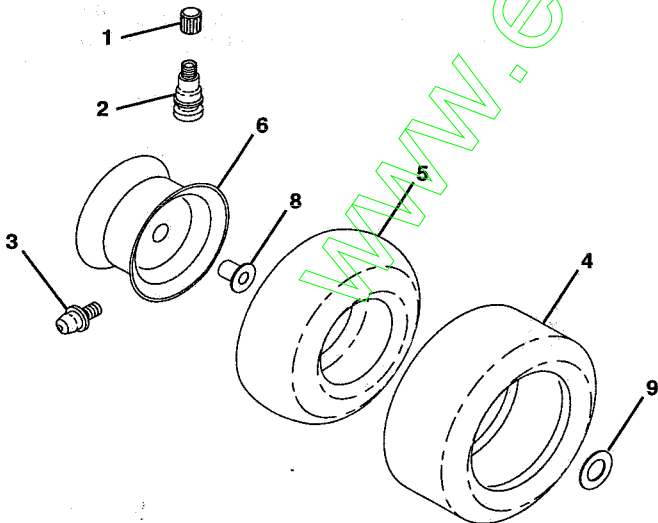

KEY NO.	PART NO.	DESCRIPTION
1	59192	Cap, Valve
2	65139	Stem, Valve
3	278H	Fitting, Grease (Front Only)
4	124142X	Tire, Front
	124243X	Tire, Rear
5	59904	Tube, Tire, Front
	8134H	Tube, Tire, Rear
		(Optional, Service Item Only)
6	122394X427	Rim Assembly, Front
	140325X427	Rim Assembly, Rear
8	9040H	Bearing, Flange (Front Only)
9	121748X	Washer, Axle Cap
--	144334	Sealant, Tire (10 oz. Tube)