

REPAIR PARTS MANUAL

42" - 16 H.P. LAWN TRACTOR

MODEL D3583-001

ONE YEAR LIMITED WARRANTY

For one (1) year from date of purchase by the first consumer for residential use (thirty (30) days commercial use), NOMA Outdoor Products Incorporated warrants that it will replace free of charge, including labor, any original part of any NOMA Outdoor Products Incorporated product found to be defective by any authorized Service Dealer or the factory, except the battery which is warranted for ninety (90) days from date of purchase.

This warranty does not cover engine, transmission, transaxle or differential (these items are covered by their manufacturer's own warranty). This warranty does not cover parts that have failed due to normal wear or parts that have failed subject to misuse or abuse. Transportation of the unit or part to and from an authorized Service Dealer or factory is the responsibility of the owner.

A step by step explanation as to what procedure should be followed for this warranty is:

1. If a part becomes defective, contact the store where the unit was purchased for the name and address of the authorized Service Dealer nearest to you.
2. If you cannot locate an authorized Service Dealer, write Service Department of NOMA Outdoor Products Incorporated for the name and address of the authorized Service Dealer in your area or call the Service Department at 1-901-422-1690.
3. Return the defective product, along with proof of purchase to such authorized Service Dealer for replacement of any defective part where covered by this warranty.

There is no other express warranty. Implied warranties, including those of merchantability and fitness for a particular purpose are limited to one (1) year from date of purchase. Liability for incidental or consequential damages are excluded.

Some states do not allow limitations on how long an implied warranty lasts, so the above limitation may not apply to you. Some states do not allow the exclusion of incidental or consequential damages, so the above exclusion may not apply to you. This warranty gives you specific legal rights, and you may have other rights which vary from state to state.

NOMA Outdoor Products Incorporated

Caller 8000

Jackson, TN 38308-8000

UNIT PARTS AND SERVICE

Fill in and mail the registration card packed with the unit. For service other than covered in this manual, contact an authorized service dealer. A nationwide parts and service organization has been established to provide locally available parts and service. When ordering repair parts, always give the following information: 1. The Part Name; 2. The Part Number; 3. The Quantity desired; 4. The Full (eight digit) Model Number of the unit. The model number will be found on a plate attached to the unit.

Look for this symbol.



It means - ATTENTION! BECOME ALERT! A HAZARD TO OPERATOR, BYSTANDER, PROPERTY OR EQUIPMENT MAY EXIST.

NOMA Outdoor Products Incorporated

Caller 8000

Jackson, TN 38308-8000

Part No. 329631A

4/93



SAFETY RULES

THESE INSTRUCTIONS ARE FOR YOUR PROTECTION. PLEASE READ THEM CAREFULLY.



IMPORTANT

THIS CUTTING MACHINE IS CAPABLE OF AMPUTATING HANDS AND FEET AND THROWING OBJECTS. FAILURE TO OBSERVE THE FOLLOWING SAFETY INSTRUCTIONS COULD RESULT IN SERIOUS INJURY OR DEATH.

I. GENERAL OPERATION:

- Know controls and how to stop quickly.
- Read, understand, and follow all instructions in the manual and on the machine before starting.
- Only allow responsible adults, who are familiar with instructions, to operate the machine.
- Wear safety glasses or eye shields when assembling or operating the machine.
- Do not operate machine when barefooted. Always wear substantial footwear, preferably steel-toed shoes.
- Do not wear loose fitting clothing that could get caught in moving parts.
- Clear the area of objects such as rocks, toys, wire, etc., which could be picked up and thrown by the blade(s).
- Be sure the area is clear of other people before mowing. Stop machine if anyone enters the area.
- Never carry passengers.
- Do not mow in reverse unless absolutely necessary. Always look down and behind before and while backing.
- Be aware of the mower discharge direction and do not point it at anyone. Do not operate the mower without either the entire grass catcher or the guard in place.
- Slow down before turning.
- Never leave a running machine unattended. Always turn off blades, set parking brake, stop engine, and remove keys before dismounting.
- Turn off blade(s) when not mowing.
- Stop engine before removing grass catcher or unclogging chute.
- Mow only in daylight or good artificial light.
- Do not operate the machine while under the influence of alcohol or drugs.
- Watch for traffic when operating near or crossing roadways.
- Use care when mowing around a fixed object to prevent the blade(s) from striking it. Never deliberately run over any foreign object.
- Use extra care when loading or unloading the machine into a trailer or truck.
- Use care when pulling loads or using heavy equipment.
 - a. Use only approved drawbar hitch points.
 - b. Limit loads to those that you can safely control.
 - c. Do not turn sharply. Use care when backing.
 - d. Use counterweight(s), wheel weight or tire chains when suggested in attachment(s) instructions.

II. SLOPE OPERATION:

Slopes are a major factor related to loss-of-control and tip-over accident, which can result in severe injury or death. All slopes require extra caution. If you cannot back up the slope or if you feel uneasy on it, do not mow it.

DO

- Mow up and down slopes, not across.
- Remove obstacles such as rocks, tree limbs, etc.
- Watch for holes, ruts, or bumps. Uneven terrain could overturn the machine. *Tall grass can hide obstacles.*
- Use slow speed. Choose a low gear so that you will not have to stop or shift while on the slope.
- Follow the manufacturer's recommendations for wheel weights or counterweights to improve stability.
- Use extra care with grass catchers or other attachments. These can change the stability of the machine.
- Keep all movement on the slopes *slow* and *gradual*. Do not make sudden changes in speed or direction.
- Avoid starting or stopping on a slope. If tires lose traction, turn off the blade(s) and proceed slowly *straight* down the slope.

DO NOT

- Do not turn on slopes unless necessary, and then slowly and gradually downhill, if possible.
- Do not mow near drop-offs, ditches or embankments. The

mower could suddenly turn over if a wheel is over the edge of a cliff or ditch, or if an edge caves in.

- Do not mow on wet grass. Reduced traction could cause sliding.
- Do not try to stabilize the machine by putting your foot on the ground.
- Do not use grass catcher on steep slopes.

III. CHILDREN:

Tragic accidents can occur if the operator is not alert to the presence of children. Children are often attracted to the machine and the mowing activity. Never assume that children will remain where you last saw them.

- Keep children out of the mowing area and under the watchful care of another responsible adult.
- Be alert and turn machine off if children enter the area.
- Before and when backing, look behind and down for small children.
- Never carry children. They may fall off and be seriously injured or interfere with safe machine operation.
- Never allow children to operate the machine.
- Use extra care when approaching blind corners, shrubs, trees, or other objects that may obscure vision.

IV. SERVICE:

- Use extra care in handling gasoline and other fuels. They are flammable and vapors are explosive.
 - a. Use only an approved container.
 - b. Never remove gas cap or add fuel with the engine running. Allow engine to cool before refueling. Do not smoke.
 - c. Never refuel the machine indoors.
 - d. Never store the machine or fuel container inside where there is an open flame, such as in a water heater.
- Check fuel supply before each use allowing space for expansion as the heat of the engine and/or sun can cause gasoline to expand and overflow the tank.
- Use extra care when handling battery acid. Acid contact with skin may cause severe burns. Eye contact may cause blindness.
- Use extra care when servicing the battery. Explosive gas is produced in the battery. Do not service the battery while smoking or near an open spark or flame. This may cause the battery to explode causing serious injury.
- Never run a machine inside a closed area. Exhaust fumes contain CARBON MONOXIDE, an ODORLESS and DEADLY GAS.
- Keep nuts and bolts, especially blade attachment bolts, tight and keep equipment in good condition.
- Never tamper with safety devices. Check their operation regularly.
- Do not change the engine governor settings or overspeed engine.
- Reduce fire hazards. Keep machine free of grass, leaves, or other debris build-up. Clean up oil or fuel spillage. Allow machine to cool before storing.
- Stop and inspect the equipment if you strike an object. Repair, if necessary, before restarting.
- Never make adjustments or repairs with the engine running.
- Grass catcher components are subject to wear, damage, and deterioration, which could expose moving parts or allow objects to be thrown. Frequently check components and replace with manufacturer's recommended parts, when necessary.
- Mower blade(s) are sharp and can cut. Wrap the blade(s) or wear gloves, and use extra caution when servicing them.
- Check brake operation frequently. Adjust and service as required.



LOOK FOR THIS SYMBOL TO POINT OUT IMPORTANT SAFETY PRECAUTIONS. IT MEANS-- ATTENTION!!! BECOME ALERT!!! YOUR SAFETY IS INVOLVED.

OWNER'S INFORMATION

Record the following information about your unit so that you will be able to provide it in case of loss or theft.

MODEL NUMBER: - (Enter complete 8 digit number from model plate on unit)

PURCHASE DATE: ___ / ___ / ___ CODE NO.: _____ SERIAL NO.: _____

DEALER'S NAME AND ADDRESS: _____

CITY: _____ STATE: _____ TELEPHONE: _____

CONTENTS OF SHIPPING CARTON

- 1 - Lawn Tractor with 42 inch Mower Deck
- 1 - Operator's Manual
- 1 - Repair Parts Manual
- 1 - Engine Manual
- 1 - Steering Wheel
- 1 - Seat
- 1 - Bag of Assembly Parts Containing :
 - 1 - Spacer Steering Shaft
 - 1 - Steering Shaft Cover (Steering Wheel Assembly)
 - 1 - Spring Pin (Steering Wheel Assembly)
 - 4 - 5/16 x 3/4 inch Hex Head Screws (Seat Assembly)
 - 4 - 5/16 inch Split Lockwashers (Seat Assembly)
 - 4 - 11/32 inch Flatwashers (Seat Assembly)
 - 2 - Gauge Wheels
 - 2 - Bolts, .500 x 1.39 D HSSH
 - 2 - Nuts, 3/8-16 Reghexctrk
 - 1 - Chute Deflector
 - 1 - Spring, Torsion Chute Deflector
 - 1 - Rod, Pivot Deck .312 D x 7.2
 - 1 - Nut, Push-On Cap .312 OD
 - 1 - Knob, Round
 - 2 - Tire & Rim PU 15 x 6 x 6
 - 4 - Washer, Flat .755 x 1.31
 - 2 - Ring, Retex .57 x .05 TRU 51
 - 2 - Hub Cap, 1.500 ID x 7/8 Lg

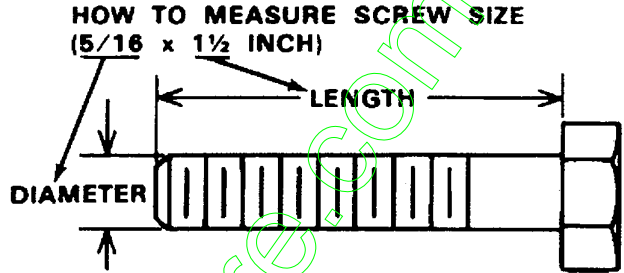

TOOLS REQUIRED FOR ASSEMBLY

- 2 - 7/16 inch Wrenches (or adjustable wrench)
- 1 - 9/16 inch Wrench (or adjustable wrench)
- 1 - 3/4 inch Wrench (or adjustable wrench)
- 1 - 1/2 inch Wrench (or adjustable wrench)
- 1 - Small Phillips Screwdriver with a 1/4 inch shank
- 1 - Hammer



DANGER



This lawn tractor can be dangerous if carelessly used.

Read your Operator's Manual thoroughly before operating your lawn tractor.

Always wear safety glasses or eye shields while assembling or operating your lawn tractor.

DO NOT carry passengers at any time.

Keep your hands, feet, hair and loose clothing away from the discharge area, the underside of the mower deck or any moving parts while the engine is running.

DO NOT allow children or young teenagers to operate or be near your lawn tractor while it is operating.

ALWAYS GIVE THE FOLLOWING INFORMATION WHEN ORDERING REPAIR PARTS:

1. The PART NUMBER; 2. The PART NAME; 3. QUANTITY DESIRED; 4. The MODEL NUMBER (As shown on Model Plate).

SEND PART ORDERS AS PER INSTRUCTIONS ON THE FRONT PAGE.

DO NOT USE KEY NUMBERS WHEN ORDERING REPAIR PARTS, ALWAYS USE PART NUMBERS.

All replacement parts will be supplied in current production colors or in a neutral color.

A handling fee is applicable to small parts orders.

YOUR UNIT IS RIGHT HAND (RH) OR LEFT HAND (LH) AS YOU STAND BEHIND IT.

42" LAWN TRACTOR MODEL D3583-001

CHASSIS & HOOD (FRONT)

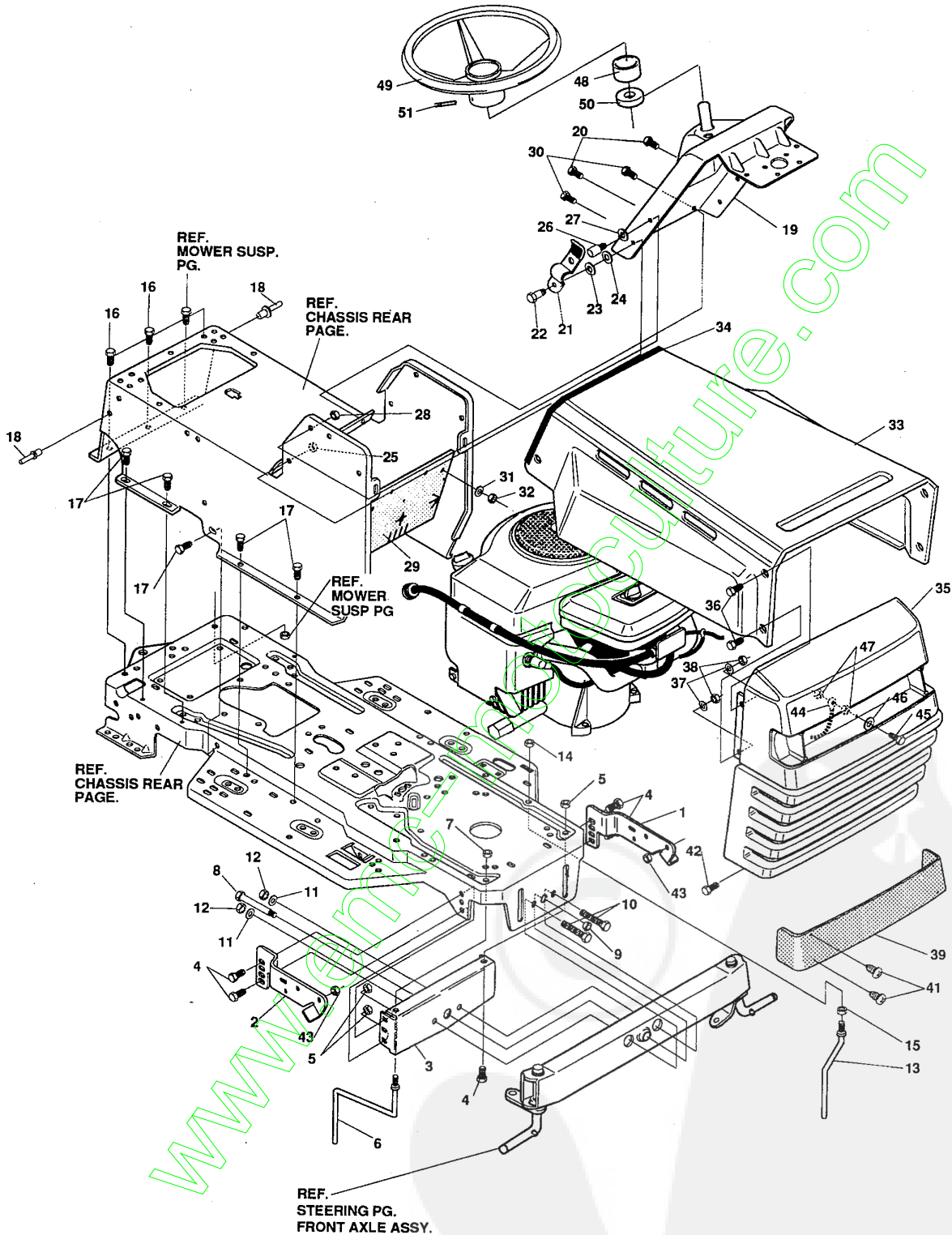

NOTE: ALWAYS USE ORIGINAL EQUIPMENT PARTS. Use of service/replacement parts other than original equipment parts may void your warranty.

ALL UNNUMBERED
ITEMS ARE INTERCHANGEABLE
WITH OPPOSITE SIDE

325875C

42" LAWN TRACTOR MODEL D3583-001

KEY#	PART#	DESCRIPTION	QTY.
1	313001-853	BRKT,GRILL LH	1
2	313002-853	BRKT,GRILL RH	1
3	313541-853	BRACKET, FRONT AXLE	1
4	56030	SCREW, 5/16-18X.75WDFLLK GR5	5
5	55273	NUT, 5/16-18 HXWDFLLK	5
6	300440	GUIDE, BELT, RIDER	1
7	1498	NUT, 5/16-18 REGHEXCTRLK	1
8	308207	BOLT, .625X2.18 HSH 1/2-13	1
9	309008	NUT, 1/2-13 HEXJAM CTRLK	1
10	122207	SCREW, 3/8-16X3.00 HHC GR2	2
11	2483	WASHER, .39IDX1.25DX.07 BELLVIL	2
12	1499	NUT, 3/8-16 REGHXCTRLK	2
13	300635	GUIDE,BELT SHORT 15" WHEEL	1
14	124824	NUT, 5/16-18 HEXJAM	1
15	271190	NUT, 3/8-16 HEXKEPS	1
16	35497	SCREW, 5/16-18X .50 WAHHTAP	2
17	995346	SCREW, 1/4-20X .50 WAHHTAP	12
18	46763	RIVET, POP	1
19	309447-860	DASHBOARD,LF SUSP DYNA	1
20	995346	SCREW, 1/4-20X .50 WAHHTAP	2
21	57159	LATCH, .94WDX.047 ASSY HOOD	2
22	8482	BOLT, .375X .156 HSH 5/16-18	2
23	120394	WASHER, FLAT .406X .81X.065	2
24	120393	WASHER, FLAT .344X .69X.065	2
25	1498	NUT, 5/16-18 REGHEXCTRLK	2
26	53446	PIN, 5/16-18 HOOD LATCH GR2-	2
27	138538	WASHER, REGINTLK.320X.61X.03	2
28	45174	NUT, 5/16-18 HEXWDFLLK WHIZ	2
29	312306	BAFFLE, CONSOLE SOUND, EXPORT	1
30	300314	SCREW, 14-20 X .88 WAHHTAP	2
31	120392	WASHER, FLAT .281 X .63 X .065	2
32	1502	NUT, 1/4-20 REGHEXCTRLK	2
33	314537-860	HOOD, LF H-20 DYNA/PRO	1
34	56304	EDGING,WIDE BLK	27.5"
35	325401	GRILLE DYNA-PRO G-17	1
36	274672	SCREW, 1/4-20X .63 WAHHC GR2	4
37	120392	WASHER, FLAT .281X .63X.065	4
38	1502	NUT, 1/4-20 REGHEXCTRLK	4
39	302333	LENS, SMOKED W/TAB NO LOGO	1
41	57796	SCREW, #6 X .50 PLASTITE/HI-LO	4
42	36149	BOLT, .375X .500 HSH 5/16-18	2
43	1498	NUT, 5/16-18 REGHEXCTRLK	2
44	310748	LANYARD,HOOD 15.77LG H15	1
45	48900	SCREW, 1/4-20X1.00 WAHHC GR2	1
46	120392	WASHER, FLAT .281X .63X.065	1
47	1502	NUT, 1/4-20 REGHEXCTRLK	2
48	311465	COVER STEERING SHAFT	1
49	301251	STEERING WHEEL	1
50	301413	SPACER FOAM	1
51	456378	ROLL PIN	1
52	329631	PARTS MANUAL	1
53	329637	OPERATOR'S MANUAL (ENGLISH)	1
54	329638	OPERATOR'S MANUAL (FRENCH)	1
55	329639	OPERATOR'S MANUAL (GERMAN)	1

42" LAWN TRACTOR MODEL D3583-001

CHASSIS & HOOD (REAR)

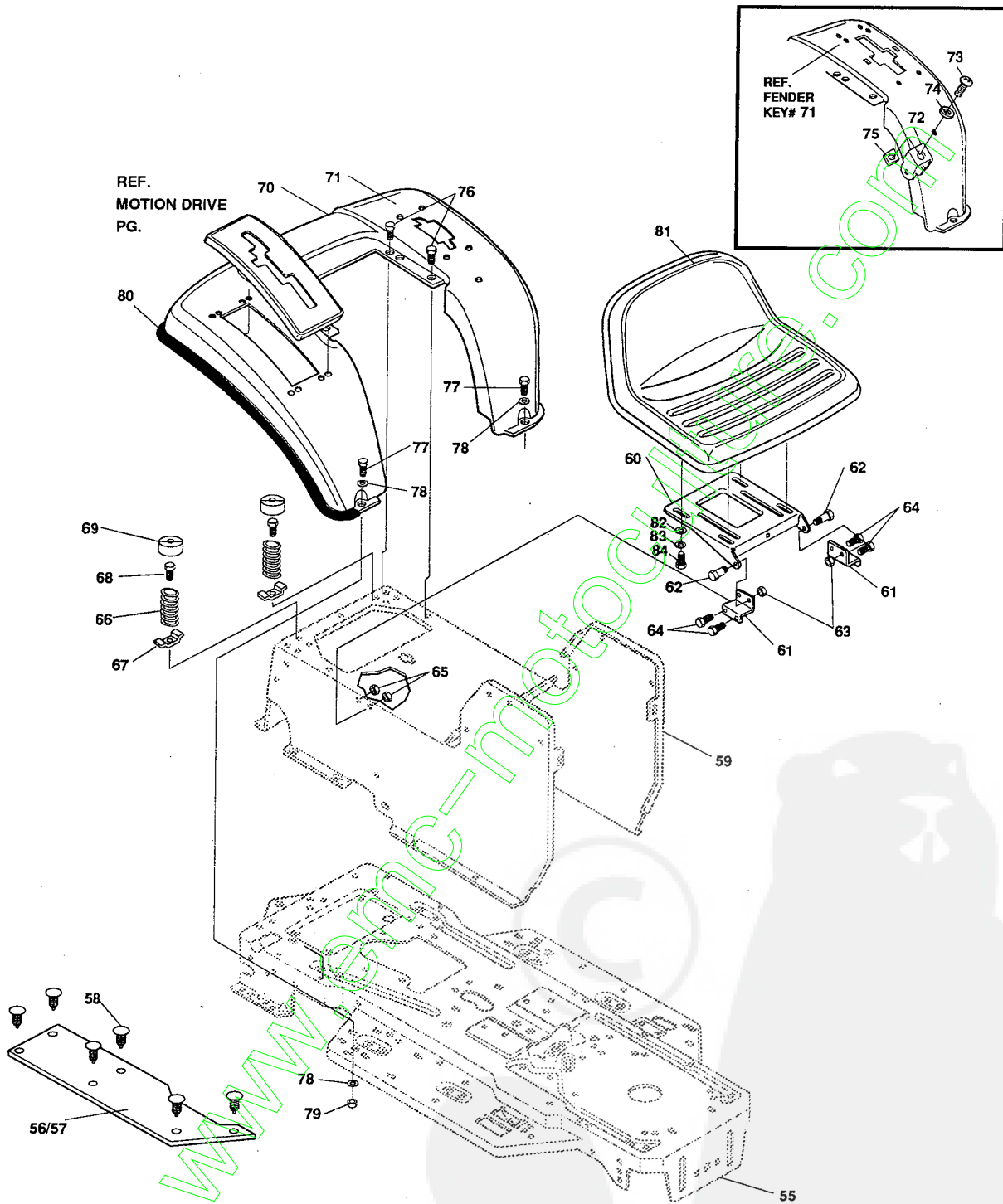

NOTE: ALWAYS USE ORIGINAL EQUIPMENT PARTS. Use of service/replacement parts other than original equipment parts may void your warranty.

ALL UNNUMBERED ITEMS ARE INTERCHANGEABLE WITH OPPOSITE SIDE

325855A

42" LAWN TRACTOR MODEL D3583-001

KEY#	PART#	DESCRIPTION	QTY.
55	326577-860	FRAME,LF MAIN 930/4360 DRILLED	1
56	310005	FOOTPAD L/H	1
57	310006	FOOTPAD R/H	1
58	309235	FASTENER RATCHET	12
59	308665-860	CONSOLE SOF	1
60	58367-853	PLATE, SEAT	1
61	310660-853	BRACKET, F-5 SEAT SUPPORT	2
62	20507	BOLT, .437X .156 HSSH 5/16-18	2
63	1498	NUT, 5/16-18 REGHEXCTRLK	2
64	48901	SCREW, 5/16-18X .63 HHC	4
65	1498	NUT, 5/16-18 REGHEXCTRLK	4
66	57153	SPRING,SEAT 2.63LG,1.49OD	2
67	1341	CLAMP,SPRING 1.17"ID	2
68	44811	SCREW, 1/4-20X .75 HXWATAP	2
69	56907	COVER,SEAT SPRING 1.5IDX1.0LG	2
70	^	FENDER ASM F5 SUSP	1
71	308653-860	FENDER F5 SUSP	1
72	9239	CLEVIS	1
73	439455	SCREW, 5/16-18X.56 PHPNMA	1
74	301551	WASHER, .344IDX1.50X.09	1
75	120373	NUT, 5/16-18 SQ	1
76	995346	SCREW, 1/4-20X .50 WAHTAP	4
77	122017	SCREW, 5/16-18X1.00 HHC	2
78	446363	WASHER, FLAT .375X .88X.082	4
79	1498	NUT, 5/16-18 REGHEXCTRLK	2
80	55021	TRIM,STRIP,BLACK	77.5"
81	57454	SEAT,GENERIC	1
82	120393	WASHER,FLAT .344X.69X.065	4
83	120638	WASHER,HVSPTLK .328X.60X.04	4
84	122007	SCREW 5/16-18X.75 HHC	4

^ ORDER INDIVIDUAL PARTS.

42" LAWN TRACTOR MODEL D3583-001

MOWER SUSPENSION ASSEMBLY

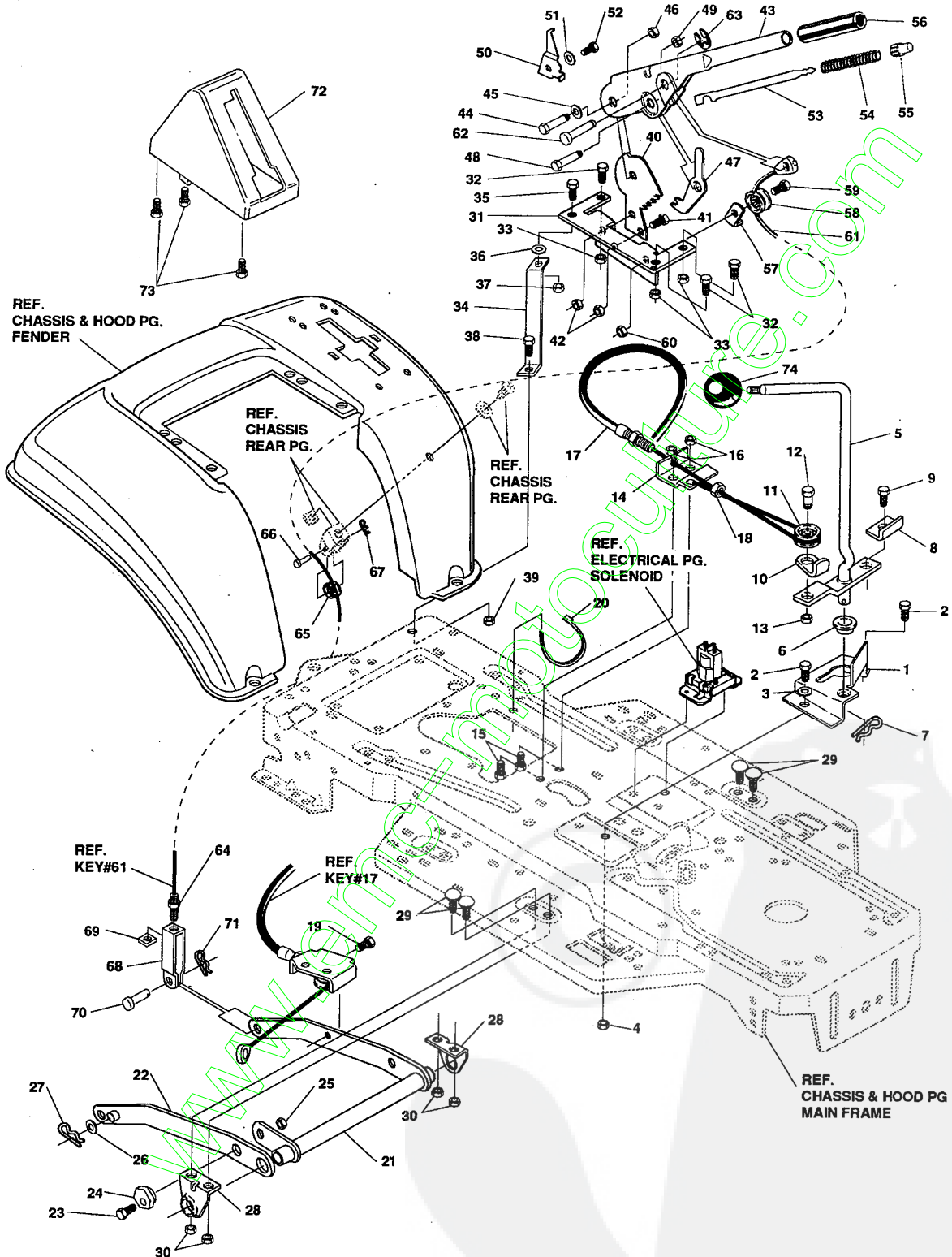

NOTE: ALWAYS USE ORIGINAL EQUIPMENT PARTS. Use of service/replacement parts other than original equipment parts may void your warranty.

ALL UNNUMBERED ITEMS ARE INTERCHANGEABLE WITH OPPOSITE SIDE

325815C

42" LAWN TRACTOR MODEL D3583-001

KEY#	PART#	DESCRIPTION	QTY.
1	320075-853	BRACKET,CLUT-ENGAGELEVER	1
2	180079	SCREW, 5/16-18X1.00 HHC	2
3	120393	WASHER, FLAT .344X .69X.065	2
4	1498	NUT, 5/16-18 REGHEXCTRLK	2
5	304791	ASSY,CLUTCH LEVER	1
6	50148	BEARING,FL. .503IDX.628OD	1
7	8260	PIN, HAIR .091 DIA X1.66LG	1
8	318341	BRACKET,SWITCH ENGAGE	1
9	35498	SCREW, 5/16-18X .75 WAHHTAP	1
10	1288	BRKT,CABLE RETAINER	1
11	48306	PULLEY, .906X.305 PM	1
12	58336	BOLT, .375X .375 HHSH 1/4-20	1
13	1502	NUT, 1/4-20 REGHEXCTRLK	1
14	300698-853	BRKT, FRAME CABLE	1
15	180020	SCREW, 1/4-20X .75 HHC	2
16	1502	NUT, 1/4-20 REGHEXCTRLK	2
17	301503	ASSY,CABLE, BLADE ENGAGE	1
18	120613	NUT, 1/4-28 HJAM	1
19	35498	SCREW, 5/16-18X .75 WAHHTAP	1
20	57444	TIE, CABLE BLACK NYLON	1
21	300158-853	ASSY,REAR LIFT	1
22	300169-853	ASSY,LINK,RIGHT SIDE	1
23	180079	SCREW, 5/16-18X1.00 HHC	1
24	58247	ADJUSTING NUT	1
25	1498	NUT, 5/16-18 REGHEXCTRLK	1
26	417098	WASHER, FLAT .531X1.06X.095	2
27	8260	PIN, HAIR .091 DIA X1.66LG	2
28	58248-853	BRKT,REAR,HANG,SUSP.	2
29	126211	BOLT, 5/16-18X .63 CARR	4
30	1498	NUT, 5/16-18 REGHEXCTRLK	4
31	313926	BRACKET,HGT/ADJUST SUPPORT	1
32	180077	SCREW, 5/16-18X .75 HHC	3
33	1498	NUT, 5/16-18 REGHEXCTRLK	3
34	300336-860	BRACE, FENDER F-5 SUS	1
35	180079	SCREW, 5/16-18X1.00 HHC	1
36	45602	WASHER, FLAT .333X .87X.119	1
37	1498	NUT, 5/16-18 REGHEXCTRLK	1
38	180079	SCREW, 5/16-18X1.00 HHC	1
39	1498	NUT, 5/16-18 REGHEXCTRLK	1
40	301238	QUADRANT,HEIGHT ADJUST	1
41	180077	SCREW, 5/16-18X .75 HHC	2
42	1498	NUT, 5/16-18 REGHEXCTRLK	2
43	322292-853	HANDLE,LIFT SHORT BLK	1
44	300171	BOLT, .500X .270 HHSH 5/16-18	1
45	996418	WASHER, FLAT .506X .75X.024	1
46	44108	NUT, 5/16-18 HWDFLCTRLK	1
47	301239	PAWL, HEIGHT ADJUST	1
48	300171	BOLT, .500X .270 HHSH 5/16-18	1
49	44108	NUT, 5/16-18 HWDFLCTRLK	1
50	9435	POINTER Z-PL	1
51	138479	WASHER, EXLK .195X.41X.03	1
52	35287	SCREW, #8-32X .38 HHWAT	1
53	303027	ROD,ACTUATOR-SHORT	1
54	58325	SPRING, HEIGHT ADJUST	1
55	58325	KNOB, HGT ADJ PUSH BUTTON	1
56	58329	GRIP .750 OD W/ HOLE	1
57	9149	BRKT, CABLE RETAIN	1
58	48306	PULLEY, .906X.305 NYLON	1
59	58336	BOLT, .375X .375 HHSH 1/4-20	1
60	1502	NUT, 1/4-20 REGHEXCTRLK	1
61	314177	CABLE, LIFT 23.30 F-5 20X8-8	1
62	300310	PIN,CLEVIS .310DIA+.475LG	1
63	300311	RING, RET E .31X.24	1
64	120375	NUT, 1/4-20 REGHEX	1
65	48306	PULLEY, .906X.305 NYLON	1
66	300317	PIN, CLEVIS .38 DIA X1.00 LG	1
67	8260	PIN, HAIR .091 DIA X1.66LG	1
68	9405	CLEVIS, LIFT CABLE	1
69	120372	NUT, 1/4-20 REGSQ	1
70	39522	PIN CLEVIS .312 X .812	1
71	121222	PIN, COTTER .090/.086X.75LG	1
72	300335	LIFT COVER-39" F5	1
73	300340	SCREW, #10 X .75 HHPLAST	3
74	55514	KNOB,ROUND 1.50 BLACK	1

42" LAWN TRACTOR MODEL D3583-001

STEERING ASSEMBLY

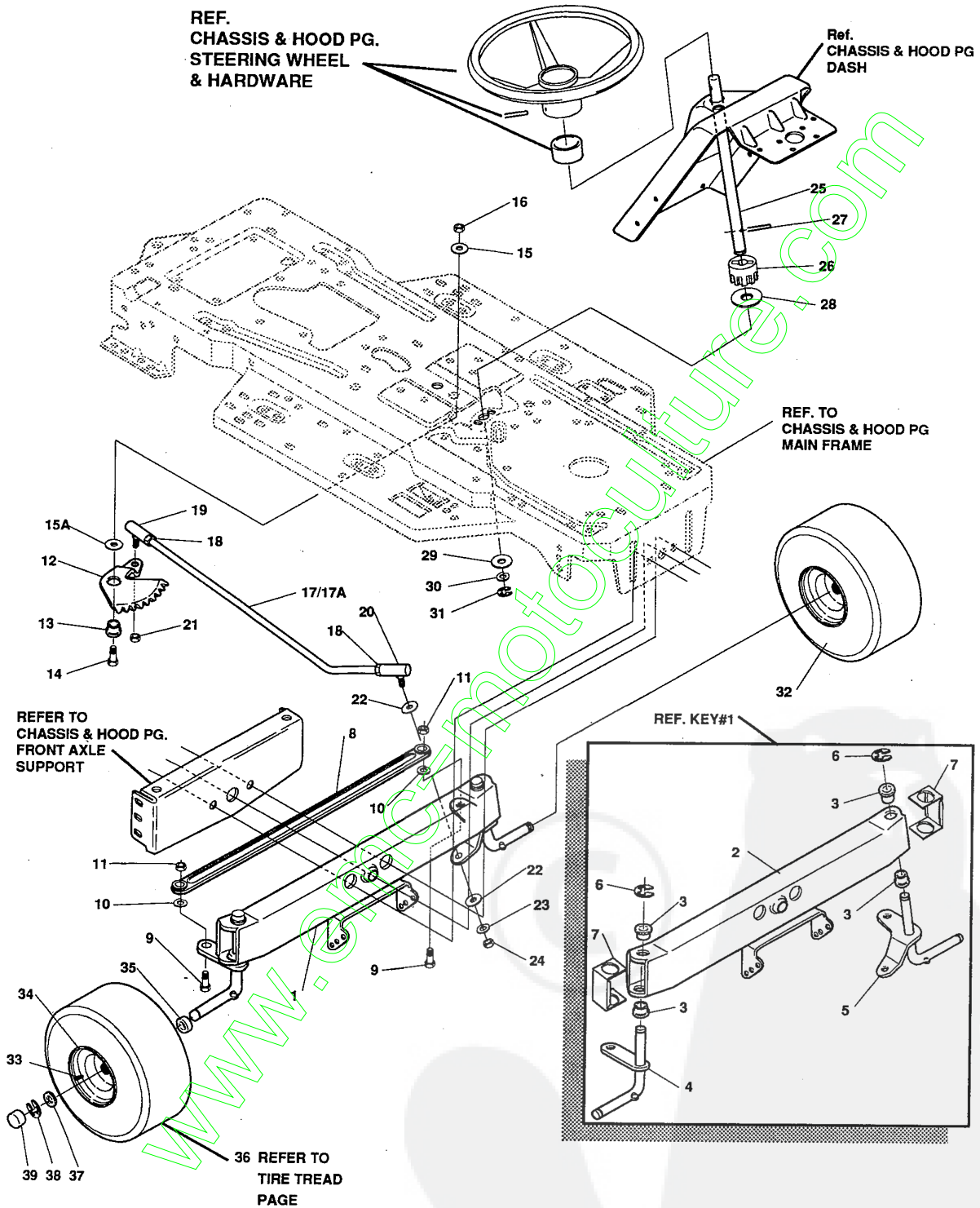

NOTE: ALWAYS USE ORIGINAL EQUIPMENT PARTS. Use of service/replacement parts other than original equipment parts may void your warranty.

ALL UNNUMBERED ITEMS ARE INTERCHANGEABLE WITH OPPOSITE SIDE

317124G

42" LAWN TRACTOR MODEL D3583-001

KEY#	PART#	DESCRIPTION	QTY.
1	^	ASSY,AXLE FRONT	1
2	300272-853	AXLE, FRONT	1
3	52407	SPINDLE BEARING	4
4	9180	SPINDLE RH LONG	1
5	314088	SPINDLE LH LONG	1
6	36625	RING, RETEX .57X.05TRU5133-75	2
7	53373-853	AXLE COVER	2
8	304590	TIE ROD ASSY 19.81LG	1
9	180128	SCREW, 3/8-16X1.75 HHC	2
10	120382	WASHER, REGSPTLK.393X.68X.10	2
11	1499	NUT, 3/8-16 REGHXCTRLK	2
12	58289	SECTOR, STEERING LF	1
13	52406	BRNG,FL ECC.510IDX .998ODX .56	1
14	180177	SCREW, 1/2-13X1.50 HHC	1
15	22265	WASHER, FLAT .515X1.38X.119	1
15A	49998	WASHER,FLAT .520X1.25X.209	1
16	1500	NUT, 1/2-13 REGHCTRLK	1
17	311100	DRAGLINK ASSY	1
17A	58291	STEERING LINK	1
18	124925	NUT, 3/8-24 REGHEXJAM	2
19	57158	BALL JOINT 3/8 THD SHORT STUD	1
20	21275	BALL JOINT 3/8 TH'D LONG STUD	1
21	46692	NUT, 3/8-24 WDFLHLK	1
22	120396	WASHER, FLAT .531X1.06X.095	2
23	120382	WASHER, REGSPTLK.393X.68X.10	1
24	120369	NUT, 3/8-24 REGHEX	1
25	58243	SHAFT, STEERING LF	1
26	58244	PINION, STEERING LF	1
27	58274	PIN,DOWEL .2500 OD+1.75	1
28	301410	BRNG, FL .752IDX1.061ODX .24	1
29	301398	WASHER, FORMED1.135X1.53X.12	1
30	21682	WASHER, FLAT .765X1.25X.042	1
31	36625	RING, RETEX .57X.05TRU5133-75	1
32	^	TIRE & RIM, PU 15X6.0X6	2
33	24167	VALVE STEM	1
34	39829	WHEEL W/BRG.	1
35	39979	BEARING,FL1.38OD+.753ID	1
36	301140	REFER TO TIRE TREAD PAGE	1
37	642	WASHER, FLAT .755X1.31X.075	4
38	36625	RING, RETEX .57X.05TRU5133-75	2
39	40394	CAP, HUB	2

^ ORDER INDIVIDUAL PARTS.

42" LAWN TRACTOR MODEL D3583-001

MOTION DRIVE ASSEMBLY

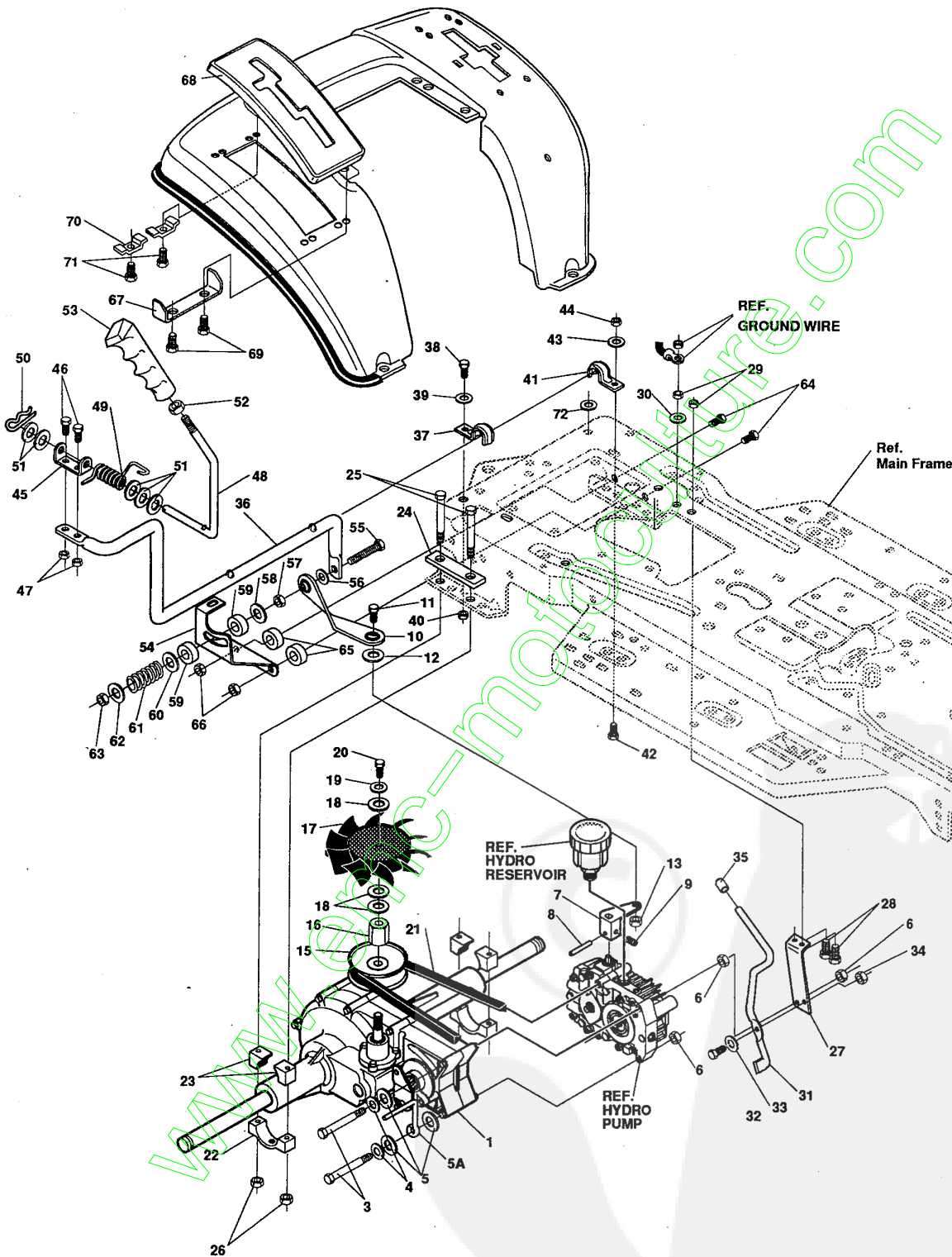

NOTE: ALWAYS USE ORIGINAL EQUIPMENT PARTS.
Use of service/replacement parts other than original equipment parts may void your warranty.

**ALL UNNUMBERED
ITEMS ARE INTERCHANGEABLE
WITH OPPOSITE SIDE**

329618A

42" LAWN TRACTOR MODEL D3583-001

KEY#	PART#	DESCRIPTION	QTY.
1	A	TRANSAXLE, AGRI/FAB HYDRO	1
3	189299	SCREW, 5/16-18X4.50 HHC	2
4	120638	WASHER, HVSP TLK .328X.60X.09	2
5	120393	WASHER, FLAT .344X .69X.065	3
5A	55480	BELT GUIDE	1
6	1498	NUT, 5/16-18 REGHEXCTRLK	3
7	310180	ARM SPEED CONTROL HYDRO	1
8	456652	PIN, SPRING.187DIA X .88LG	1
9	102570	SCREW, 1/4-20X .38 ALHSETCPPT	1
10	314236	LINK, SHIFT LF HYDRO	1
11	122145	SCREW, 3/8-16X1.25 HHC	1
12	120382	WASHER, REGSPLTLK .393X.68X.10	1
13	1499	NUT, 3/8-16 REGHXCTRLK	1
15	310098	PULLEY ASSY HYDRO	1
16	310094	NUT PULLEY 1/2-20 AND 1/4-20	1
17	308523	FAN, HYDRO 7.00DIA-10 BLADES	1
18	908492	WASHER, FLAT .28X1.38X.07	3
19	120380	WASHER, REGSPLTLK.263X.49X.07	1
20	180018	SCREW, 1/4-20X .62 HHC	1
21	314572	BELT, V 4L 80.16 HYDRO LF	1
22	310187	MOUNTING BLOCKS HYDRO	2
23	310813	MOUNTING BLOCK LH HYDRO	4
24	313371	PLATE GUIDE	2
25	180112	SCREW, 5/16-18X2.75 HHC	4
26	1498	NUT, 5/16-18 REGHEXCTRLK	4
27	314221	STABILIZER BRACKET LF HYDRO	1
28	122017	SCREW, 5/16-18X1.00 HHC	2
29	1498	NUT, 5/16-18 REGHEXCTRLK	2
30	138538	WASHER, REGINLK .320X.61X.03	1
31	314222	ROD-DUMP VALVE LF HYD.ZINC	1
32	310088	BOLT, .250X .312 HSSH 5/16-18	1
33	2483	WASHER, .39ID X1.25DX.07 BELLVIL	1
34	1502	NUT, 1/4-20 REGHEXCTRLK	1
35	7289	RUBBER STOP	1
36	314281-853	LEVER,SHIFT-LWR LF HYDRO	1
37	310347-853	CLIP-SHIFT LEVER .62 ROD	1
38	180077	SCREW, 5/16-18X .75 HHC	1
39	996416	WASHER, FLAT .391X1.00X.125	1
40	1498	NUT, 5/16-18 REGHEXCTRLK	1
41	310347-853	CLIP-SHIFT LEVER .62 ROD	1
42	180077	SCREW, 5/16-18 REGHEXCTRLK	1
43	996416	WASHER, FLAT .391X1.00X.125	1
44	1498	NUT, 5/16-18 REGHEXCTRLK	1
45	310356	PIVOT BRKT LEVER BLACK	1
46	180018	SCREW, 1/4-20X .62 HHC	2
47	1502	NUT, 1/4-20 REGHEXCTRLK	2
48	318452	LEVER, SHIFT UPPER SF 1/2-13TH	1
49	318451	SPRING, TORS. .56X.95X.095	1
50	8260	PIN, HAIR .125 DIA X1.00LG	1
51	2968	WASHER	5
52	120238	NUT, 1/2-13 HEXJAM	1
53	306690	HANDLE 1/2-13 MOLDED BLACK 173	1
54	314473-853	QUADRANT, SPEED CONTROL	1
55	7288	SCREW, 3/8-16X3.00 HHCFT	1
56	120382	WASHER, REGSPLTLK .393-16X3.00	1
57	45171	NUT, 3/8-16 HWD FL WHIZ NUT	1
58	845	WASHER, FLAT .390X1.25X.119	1
59	314944	WASHER, FRICTION	2
60	845	WASHER, FLAT .390X1.25X.119	1
61	29170	SPRING	1
62	274517	WASHER, FLAT .406X.73X.063	1
63	1499	NUT, 3/8-16 REGHXCTRLK	1
64	180081	SCREW, 5/16-18X1.25 HHC	2
65	314702	SPACER .344 X 1.00 X .500	2
66	1498	NUT, 5/16-18 REGHEXCTRLK	2
67	311257-853	BRACKET COVER	1
68	314244	COVER PLASTIC	1
69	311331	SCREW, 174-15X .44/.53 HILOHHWA	2
70	1341	CLAMP SPRING	2
71	311331	SCREW, 174-15X .44/.53 HILOHHWA	2
72	309436	PUSHNUT,5/16 BOLT RETAINER	1

^ CONTACT YOUR NEAREST TRANSAXLE DEALER FOR PARTS AND SERVICE.

42" LAWN TRACTOR MODEL D3583-001

MOTION DRIVE ASSEMBLY

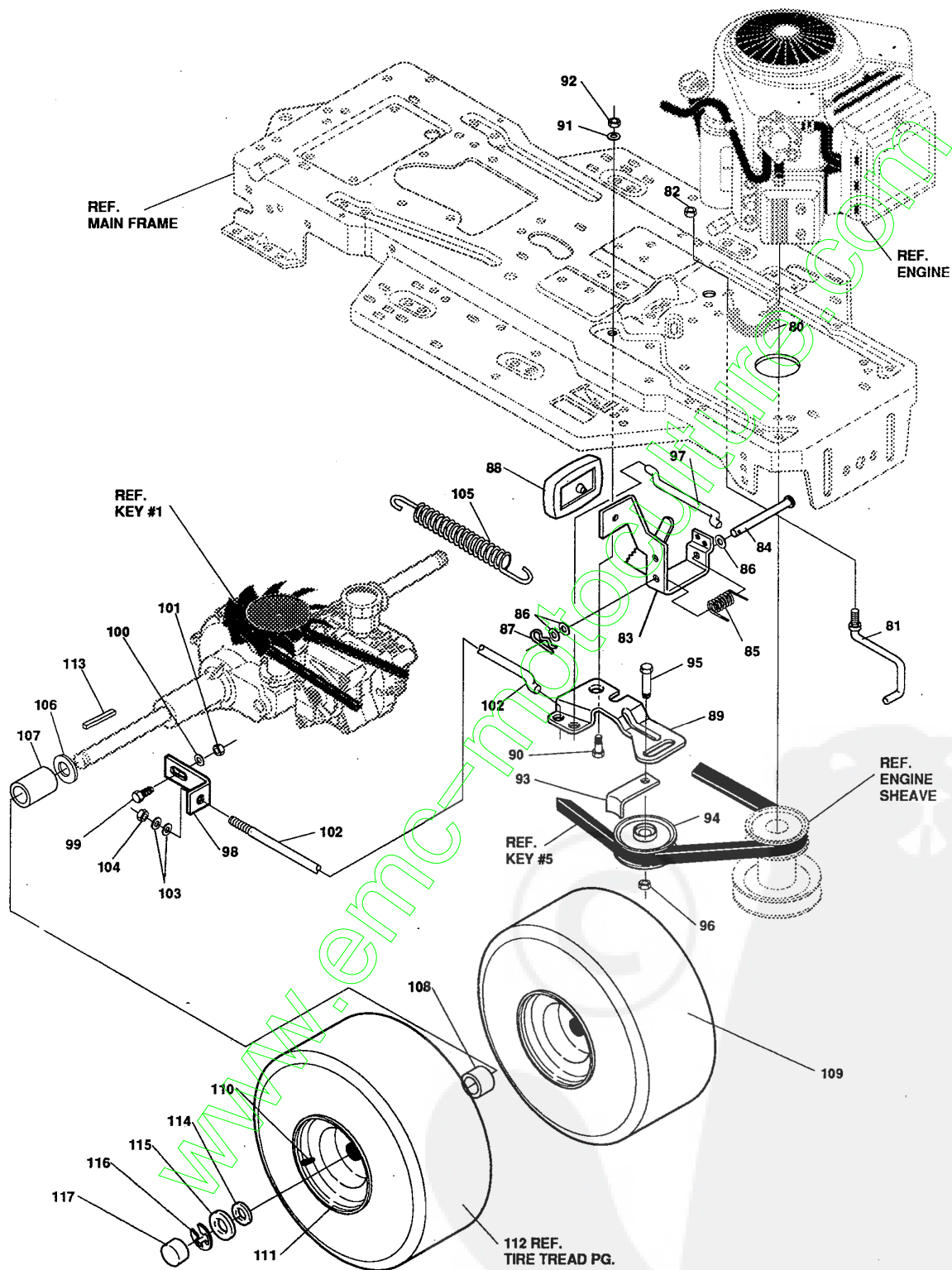

NOTE: ALWAYS USE ORIGINAL EQUIPMENT PARTS.
Use of service/replacement parts other than original equipment parts may void your warranty.

**ALL UNNUMBERED
ITEMS ARE INTERCHANGEABLE
WITH OPPOSITE SIDE**

329618A

42" LAWN TRACTOR MODEL D3583-001

KEY#	PART#	DESCRIPTION	QTY.
80	321514	SPRING BIAS DRAGLINK	1
81	304016	GUIDE BELT	1
82	1498	NUT, 5/16-18 REGHEXCTRLK	1
83	325942	PEDAL ASSY,BRAKE/CLUTCH LF	1
84	319675	PIN,CLEVIS	1
85	57847	SPRING, BRAKE PEDAL	1
86	2968	WASHER, FLAT .504X .75X.059	3
87	56180	PIN,HAIR	1
88	48160	PAD, CLUTCH BRAKE W/PRINTING	1
89	320381-853	ARM,IDLER TRACTION DR. LF	1
90	300793	BOLT, .625X .135 HSH 5/16-18	1
91	45602	WASHER, FLAT .333X .87X.119	1
92	1498	NUT, 5/16-18 REGHEXCTRLK	1
93	39659	RETAINER, STRAP BELT	1
94	35374	PULLEY, IDLER V4L 3.06X .62	1
95	45892	BOLT, 3/8-16X1.50 CARR	1
96	1499	NUT, 3/8-16 REGHXCTRLK	1
97	57204	ROD, CLUTCH	1
98	57217	BRACKET, BRAKE ROD	1
99	20507	BOLT, .437X .156 HSH 5/16-18	1
100	45602	WASHER, FLAT .333X .87X.119	1
101	1498	NUT, 5/16-18 REGHEXCTRLK	1
102	316293	ROD, BRAKE LT 920 LF 22.25	1
103	120393	WASHER, FLAT .344X.69X.065	2
104	1498	NUT, 5/16-18 REGHEXCTRLK	1
105	56359	SPRING, CLUTCH .113X.750X8.75	1
106	42815	WASHER, FLAT .755X1.53X.07	2
107	57479	SPACER, .75 X 1.25 X 1.32	2
108	301565	SPACER, SLEEVE	2
109	^	TIRE & RIM 20X8-8 GENERIC	2
110	24167	VALVE STEM	1
111	57165	RIM, WHEEL	1
112		REFER TO TIRE TREAD PAGE	
113	52928	KEY, SQUARE .187SQX2.25LG	2
114	642	WASHER, FLAT .755X1.31X.075	4
115	42815	WASHER, FLAT .755X1.53X.07	2
116	36625	RING, RETEX .57X.05TRU5133-75	2
117	40394	CAP, HUB	2

^ ORDER INDIVIDUAL PARTS

42" LAWN TRACTOR MODEL D3583-001

ENGINE & CONTROL ASSEMBLY

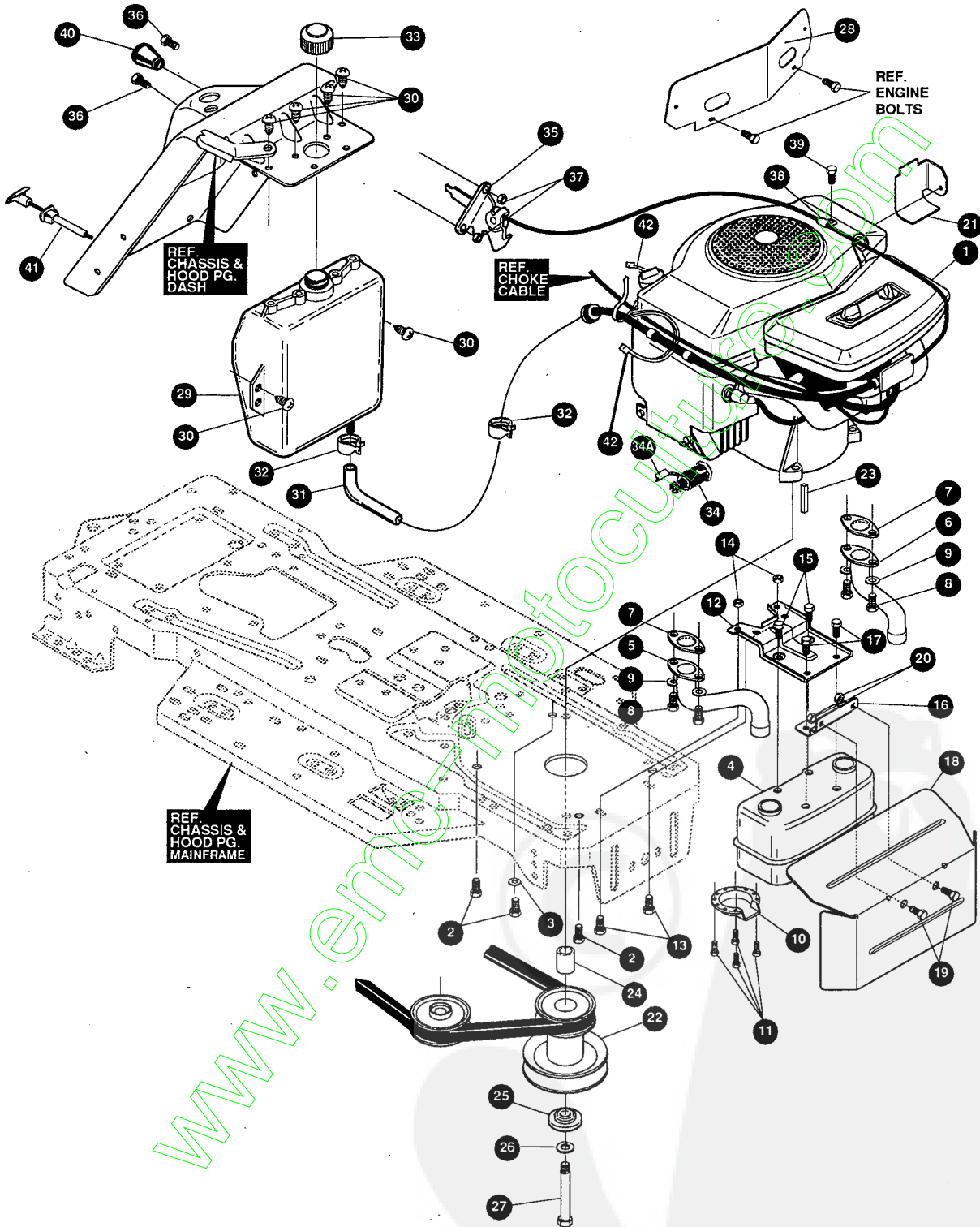

NOTE: ALWAYS USE ORIGINAL EQUIPMENT PARTS. Use of service/replacement parts other than original equipment parts may void your warranty.

ALL UNNUMBERED ITEMS ARE INTERCHANGEABLE WITH OPPOSITE SIDE

326267B

42" LAWN TRACTOR MODEL D3583-001

KEY#PART#	DESCRIPTION	QTY.
1. ^	B&S 14-18 STD/IC DUAL CIR.	1
2. 50947	SCREW, 3/8-16X1.25 WAHHTAPBLKP	4
3. 138489	WASHER, EXLK .384X.69X.04	1
4. 305550	MUFFLER, 16/18HP LARGE LO-TONE	1
5. 305552	EXHAUST TUBE 18HP B&S RH	1
6. 305551	EXHAUST TUBE 18HP LH	1
7. 56640	GASKET, MUFFLER	2
8. 180020	SCREW, 1/4-20X .75 HHC GR5	4
9. 120380	WASHER, REGSPTLK.263X.49X.07	4
10. 56472	DEFLECTOR SIDE OUT (BS222573)	1
11. 35287	SCREW, #8-32X .38 HHWATAPGR2	4
12. 304709-853	BRACKET, MUFFLER	1
13. 56030	SCREW, 5/16-18X.75WDFLLK GR5	2
14. 55273	NUT, 5/16-18 HXWDFLLK	2
15. 995346	SCREW, 1/4-20X .50 WAHHTAP	2
16. 9796	ML BRACKET, TRANSAXLE MOUNTING	1
17. 995338	SCREW, 1/4-20X .63 HHWATAP	2
18. 308644-853	MP SHIELD, MUFFLER HEAT 18HPB&S	1
19. 180077	SCREW, 5/16-18X .75 HHC GR5	2
20. 55273	NUT, 5/16-18 HXWDFLLK	2
21. 56470-853	MP DEFLECTOR, COOL AIR	1
22. 316802	PULLEY, ENG V3L 4.00 OFFSET	1
23. 57791	KEY, SQUARE .250SQ X 5.00LG	1
24. 304246	SPACER, SLEV1.01X1.484X	1
25. 56431	WASHER, 980IDX1.38ODX.437PILOT	1
26. 120383	WASHER, REGSPTLK.459X.78X.12	1
27. 428644	SCREW, 7/16-20X5.00 HHC BLK PH	1
28. 52796-853	MP BULKHEAD, HOOD H-8	1
29. 314992	TANK, FUEL 2 GAL CLEAR	1
30. 49050	SCREW, 1/4-10X .75PHPNTAPGR2BK	6
31. 41007	TUBING, .25X.50X BULK GAS LINE	15
32. 47345	CLAMP, FUEL LINE RED	2
33. 46704	CAP, GAS 1-1/2-7 THD BLK	1
34. 325547	OIL DRAIN ITW	1
34A 327422	OIL DRAIN CAP	
35. 300456	CONTROL, THROTTLE 31LG TWIN BS	1
36. 320553	SCREW, 10-24X.63PHPNMA CRSS	2
37. 271166	NUT, #10-24 HEXKEPS	2
38. 56538	RETAINER, WIRE	1
39. 35258	SCREW, 10-24X.38 SLHWATAPGR2	1
40. 50607	KNOB, ROUND THROTTLE BLACK	1
41. 300432	CONTROL, CHOKE 47.13LG PAN TK	1
42. 57444	TIE, CABLE BLACK NYLON 5.62L	2

^ SEE ENGINE MANUAL

42" LAWN TRACTOR MODEL D3583-001

PRE-PAINTED DECK ASSEMBLY

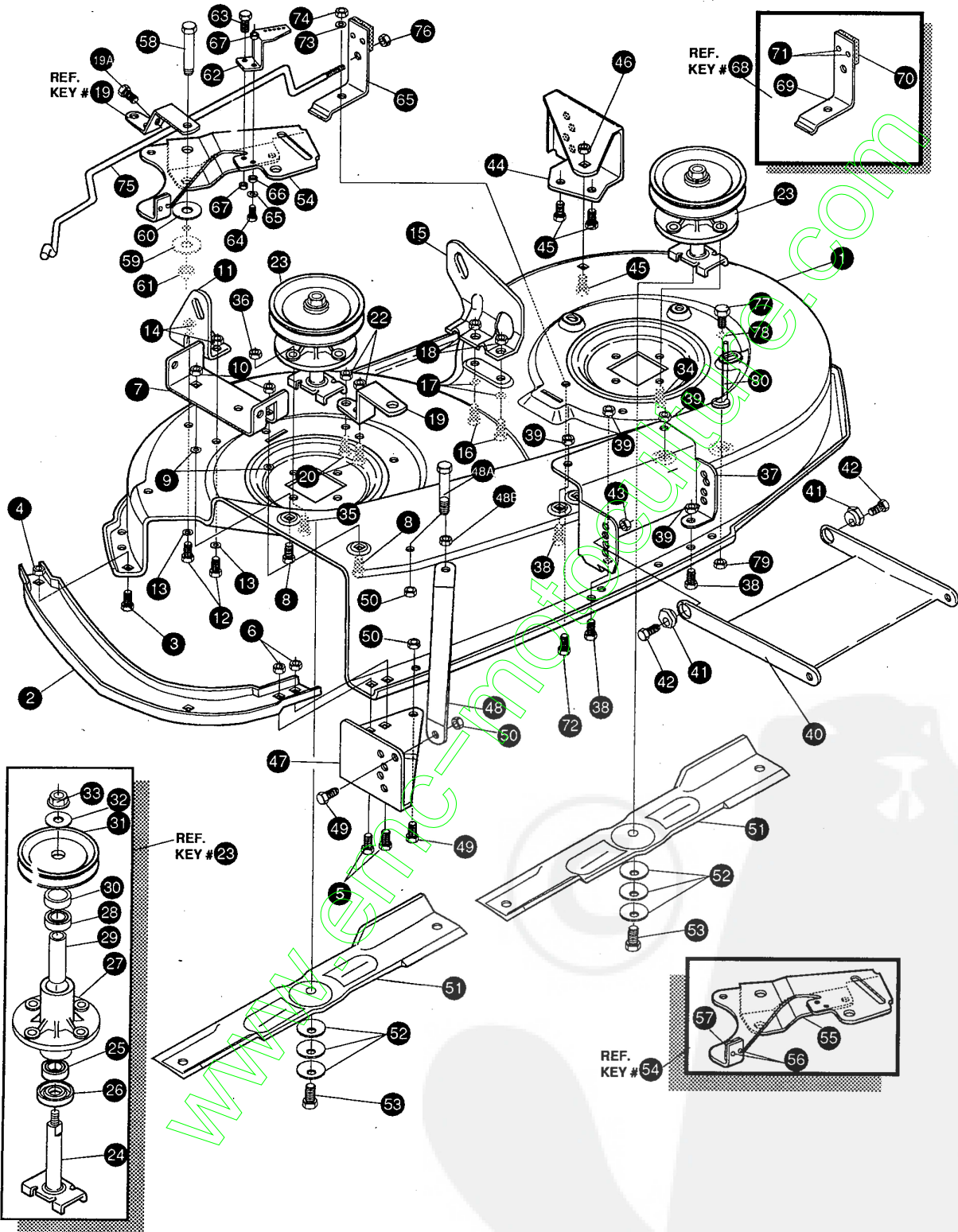

NOTE: ALWAYS USE ORIGINAL EQUIPMENT PARTS. Use of service/replacement parts other than original equipment parts may void your warranty.

ALL UNNUMBERED ITEMS ARE INTERCHANGEABLE WITH OPPOSITE SIDE

324144E

42" LAWN TRACTOR MODEL D3583-001

KEY#	PART#	DESCRIPTION	QTY.
1	325116-853	MOWER DECKS, RIDER 42"	1
2	326480-853	TOE GUARD	1
3	180075	SCREW, 5/16-18X .63 HHC	1
4	1498	NUT, 5/16-18 REGHEXCTRLK	1
5	122007	SCREW, 5/16-18X .75 HHC	2
6	1498	NUT, 5/16-18 REGHEXCTRLK	2
7	317017	BRACKET CHUTE MOUNT	1
8	180075	SCREW, 5/16-18X .63 HHC	2
9	120393	WASHER, FLAT .344X.69X.065	2
10	1498	NUT, 5/16-18 REGHEXCTRLK	2
11	313929	LIFT BRACKET, REAR, RH	1
12	180077	SCREW, 5/16-18X .75 HHC	2
13	120393	WASHER, FLAT .344X .69X.065	2
14	1498	NUT, 5/16-18 REGHEXCTRLK	2
15	310667	BRACKET, DECK LIFTREAR LH	1
16	180077	SCREW, 5/16-18X .75 HHC GR5	2
17	120393	WASHER, FLAT .344X .69X.065	2
18	1498	NUT, 5/16-18 REGHEXCTRLK	2
19	326893-853	BRACE IDLER	1
19A	308231	SCREW, 1/4-20X1.25 HHWATAP	1
20	180077	SCREW, 5/16-18X .75 HHC	2
22	44108	NUT, 5/16-18 HWDFLCTRLK	2
23	56424-853	QUILL ASSY, 36/39/40/43	2
24	56425	SHAFT/SADDLE 36"	1
25	49562	BRNG, BALL	1
26	50616	DUST SHIELD	1
27	55547	QUILL CASTING (1046)	1
28	49562	BRNG, BALL	1
29	50818	SPACER, 3.797LGX.669IDX.88OD	1
30	51449	SPACER, 438LGX.932ODX.672ID	1
31	313898	PULLEY, 26/36" QUILL V5L	1
32	56365	SPECIAL WASHER	1
33	1282	NUT, 7/16-20 WDFLLK	1
34	50634	SCREW, 5/16-18X .88 WAHHTAP	7
35	300345	SCREW, 5/16-18X1.38 WATAP	1
36	1498	NUT, 5/16-18 REGHEXCTRLK	1
37	317040	BRACKET FRT.	1
38	180075	SCREW, 5/16-18X .63 HHC	4
39	1498	NUT, 5/16-18 REGHEXCTRLK	4
40	58305-853	LINK BRACKET, DECK FR	1
41	58247	ADJUSTING NUT	2
42	122017	SCREW, 5/16-18X1.00 HHC	2
43	1498	NUT, 5/16-18 REGHEXCTRLK	2
44	317041	BRACKET, GAGE WHEEL L.H.	1
45	180075	SCREW, 5/16-18X .63 HHC	3
46	1498	NUT, 5/16-18 REGHEXCTRLK	3
47	322464-853	BRACKET, GAGE WHEEL R.H. FRNT	1
48	314282-853	BRACKET, STABILIZER	1
48A	311104	SCREW 5/16-18X5.00 HHC GR.5	1
48B	271184	NUT, 5/16 HEX KEPS	1
49	180075	SCREW, 5/16-18X .63 HHC	2
50	1498	NUT, 5/16-18 REGHEXCTRLK	3
51	326961	BLADE, LOW-LIFT 21.70	2
52	2483	WASHER, .39IDX1.25DX.07 BELLVIL	6
53	39573	SCREW, 3/8-24X1.00 NYLHHC	2
54	320576-853	IDLER ARM ASSY	1
55	322116-853	IDLER ARM	1
56	41601	RIVET	2
57	306973	BRAKE PAD	1
58	304420	SHOULDER BOLT	1
59	996416	WASHER, FLAT 391X1.00X.125	1
60	996307	WASHER, FLAT .391X1.00X.209	1
61	45171	NUT, 3/8-16 HWDFL WHIZ-LOCK	1
62	300700-853	BRACKET, EXTENSION IDLER	1
63	180075	SCREW 5/16-18X.63 HHC GR.5	1
64	180083	SCREW, 5/16-18X1.50 HHC GR.5	1
65	446363	WASHER, FLAT	1
66	271184	NUT 5/16-18 HEX KEPS	1
67	1498	NUT	2
68	321828-853	BLADE BRAKE ASSY	1
69	304119-853	BRAKE ARM	1
70	306973	BRAKE PAD	1
71	135624	RIVET	2
72	180075	SCREW, 5/16-18X.63	1
73	120393	WASHER, FLAT .344X.69X.065	1
74	1498	NUT, 5/16-18 REGHEXCTRLK	1
75	314079	ROD, BRAKE	1
76	1502	NUT, 1/4-20 REGHEXCTRLK	1
77	180079	SCREW, 5/16-18X1.00 HHC GR5	1
78	120393	WASHER, FLAT .344X.69X.065	1
79	1498	NUT, 5/16-18 REGHEXCTRLK	1
80	325965	BELT GUIDE 43" DECK UPSTOP	1

42" LAWN TRACTOR MODEL D3583-001

FINAL DECK ASSEMBLY

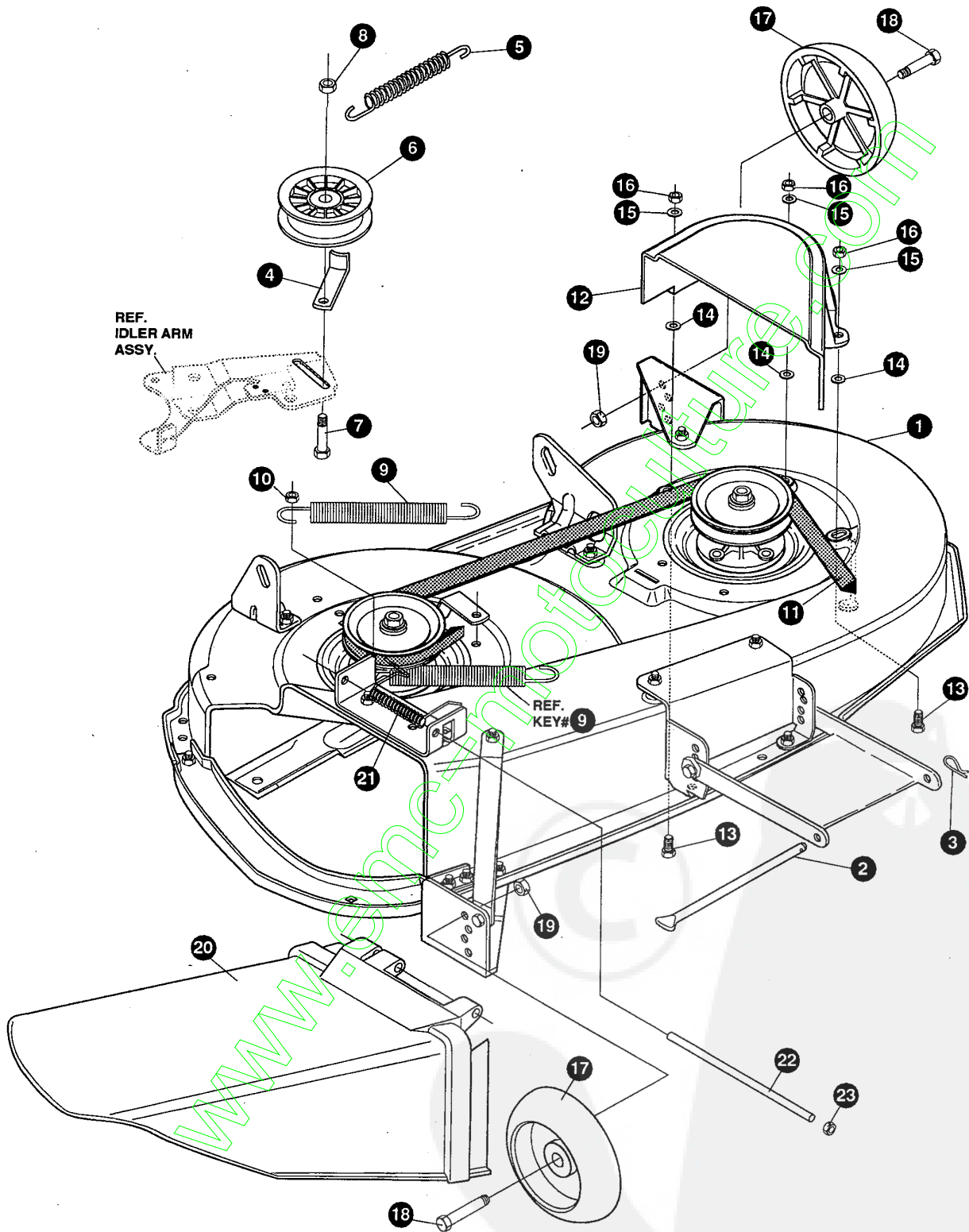

NOTE: ALWAYS USE ORIGINAL EQUIPMENT PARTS.
Use of service/replacement parts other than original equipment parts may void your warranty.

**ALL UNNUMBERED
ITEMS ARE INTERCHANGEABLE
WITH OPPOSITE SIDE**

326401C

42" LAWN TRACTOR MODEL D3583-001

KEY#	PART#	DESCRIPTION	QTY.
1	^	DECK,42" MOWER 2-WH BLACK 853 EXPORT	1
2	58306	ROD, DECK HITCH	1
3	8260	PIN, HAIR .091 DIA X 1.66 LG	1
4	1346	GUIDE, BELT, IDLER	1
5	314107	SPRING, TENSION 5.00 LG + 17 LB / IN	1
6	310326	PULLEY, IDLER BFF 4.00 WIDE FL	1
7	126416	BOLT, 3/8-16 X 1.75 CARR	1
8	44374	NUT, 3/8-16 HX WDFLLK	1
9	35410	SPRING .071 X .62 X 4.37	1
10	1498	NUT, 5/16-18 REG HEX CTRLK	1
11	314108	BELT, V 5L 86.00 KEVLAR	1
12	324814	GUARD, BELT LH PLASTIC	1
13	57101	CARRIAGE BOLT	3
14	309436	PUSHNUT 5/16 NON-SERVICEABLE	3
15	120393	WASHER, FLAT .344 X .69 X .065	3
16	1498	NUT, 5/16-18 REG HEX CTRLK	3
17	302611	GUAGE WHEEL EURO	2
18	23763	BOLT, 5.00 X 1.39 HHSH	2
19	1499	NUT, 3/8-16 REG HEX CTRLK	2
20	304422	CHUTE DEFLECTOR 40", 42", 43"	1
21	314975	TORSION SPRING	1
22	304424	ROD, PIVOT DECK	1
23	3535	PUSH NUT	1

^ ORDER DECK KIT# 329036 FOR COMPLETE DECK.

42" LAWN TRACTOR MODEL D3583-001

ELECTRICAL ASSEMBLY

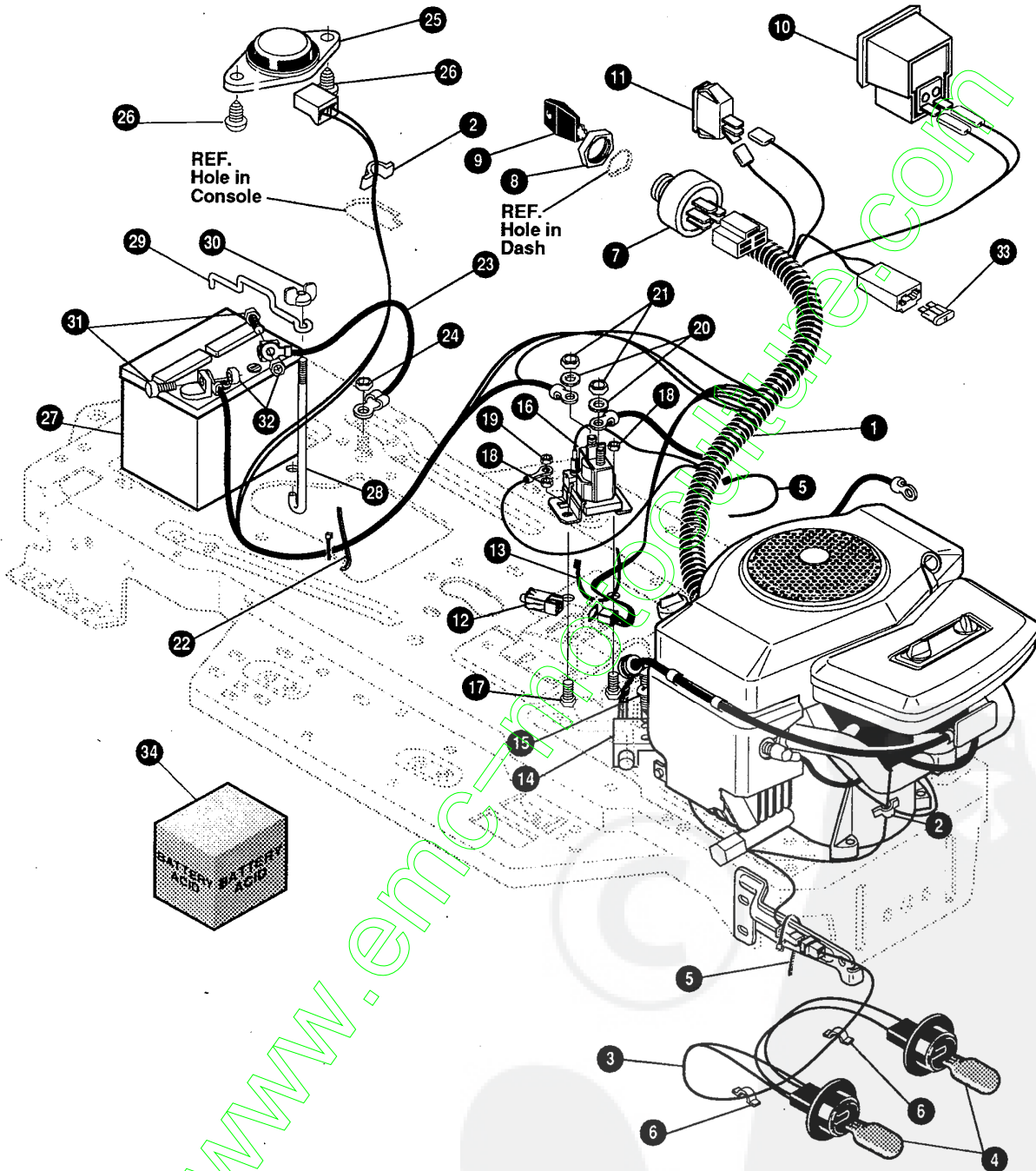

NOTE: ALWAYS USE ORIGINAL EQUIPMENT PARTS. Use of service/replacement parts other than original equipment parts may void your warranty.

ALL UNNUMBERED ITEMS ARE INTERCHANGEABLE WITH OPPOSITE SIDE

325513C

42" LAWN TRACTOR MODEL D3583-001

KEY#	PART#	DESCRIPTION	QTY.
1.	322798	WIRE HARNESS 14-18TWIN OPP DYN	1
2.	41482	PRESS CLIP, 1.380LG .255ID	2
3.	303064	ASSY, LIGHT WIRE-1/4 TURN	1
4.	52572	BULB, HEADLAMP	2
5.	322585	TIE, CABLE BLACK NYLON 5.62L	2
6.	41482	PRESS CLIP, 1.380LG .255ID	2
7.	327355	SWITCH-IGN.(AFTER FIRE) 3 POSN	1
8.	327352	NUT, 5/8-32 HXHD IGN SWIT	1
9.	327350	KEY, IGNITION SWITCH	1
10.	300133	AMMETER	1
11.	300334	LIGHT SWITCH ON/OFF PANEL	1
12.	320082	SWITCH, DOUBLE POLE NO/NC BLACK	1
13.	57444	TIE, CABLE BLACK NYLON 5.62L	1
14.	57476	SWITCH, SCR MNT DP NC NO	1
15.	57220	SCREW, #12 X .50 PHPNHTAP	2
16.	53716	SOLENOID	1
17.	187745	SCREW, 1/4-20X .75 HXSEMMA	2
18.	1502	NUT, 1/4-20 REGHEXCTRLK	2
19.	271172	NUT, 1/4-20 REGHEXKEPS	1
20.	138485	WASHER, EXLK .320X.61X.03	2
21.	120368	NUT, 5/16-24 REGHEX	2
22.	57444	TIE, CABLE BLACK NYLON	1
23.	55511	WIRE, GROUND, 12.5"	1
24.	271184	NUT, 5/16-18 HEXKEPS	1
25.	57547	SWITCH, SEAT	1
26.	160505	SCREW, 1/4-20X .38PHPNHMA	2
27.	302257	BATTERY 12VOLT	1
28.	57551	ROD, BATTERY	1
29.	57552	ROD, BATTERY, TOP	1
30.	325232	NUT, WING 1/4-20 NYLON	1
31.	120854	SCREW, 1/4-20X .63 HHC	2
32.	271172	NUT, 1/4-20 REGHEXKEPS	2
33.	** 302031	FUSE, 15 AMP SPADE TYPE	1
34.	^	BATTERY ACID, 80 OZ.	1

** SPADE TYPE FUSES ARE INCLUDED WITH THE WIRE HARNESS.
 ^ CAN BE PURCHASED LOCALLY.

WIRING SCHEMATIC

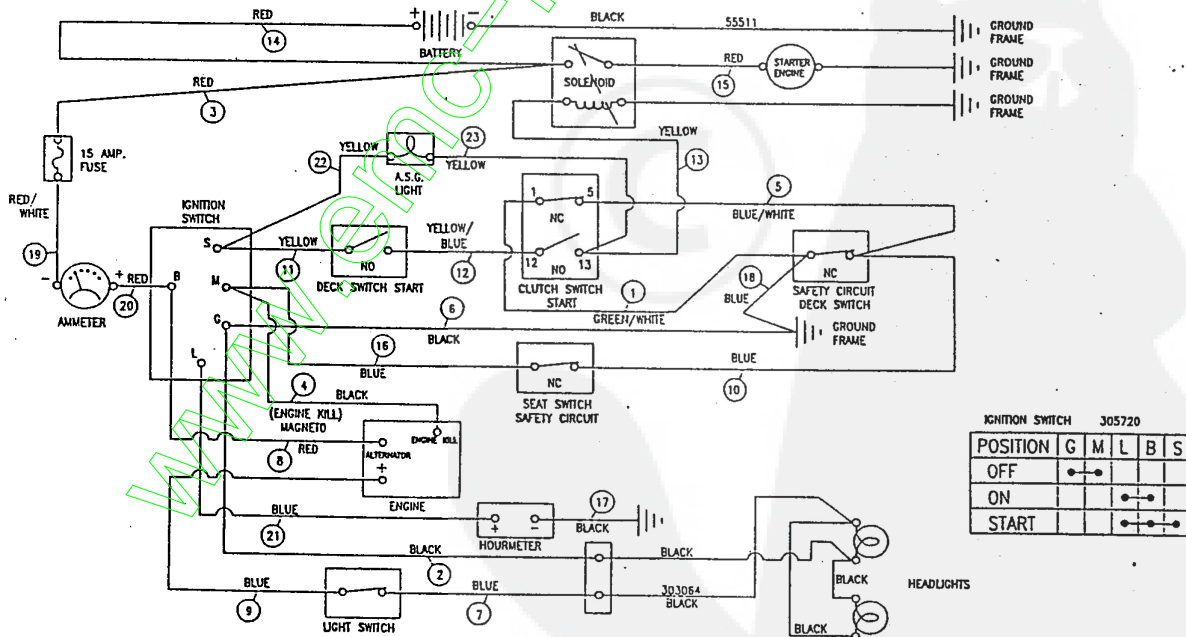

42" LAWN TRACTOR MODEL D3583-001

DECALS (DECORATIVE)

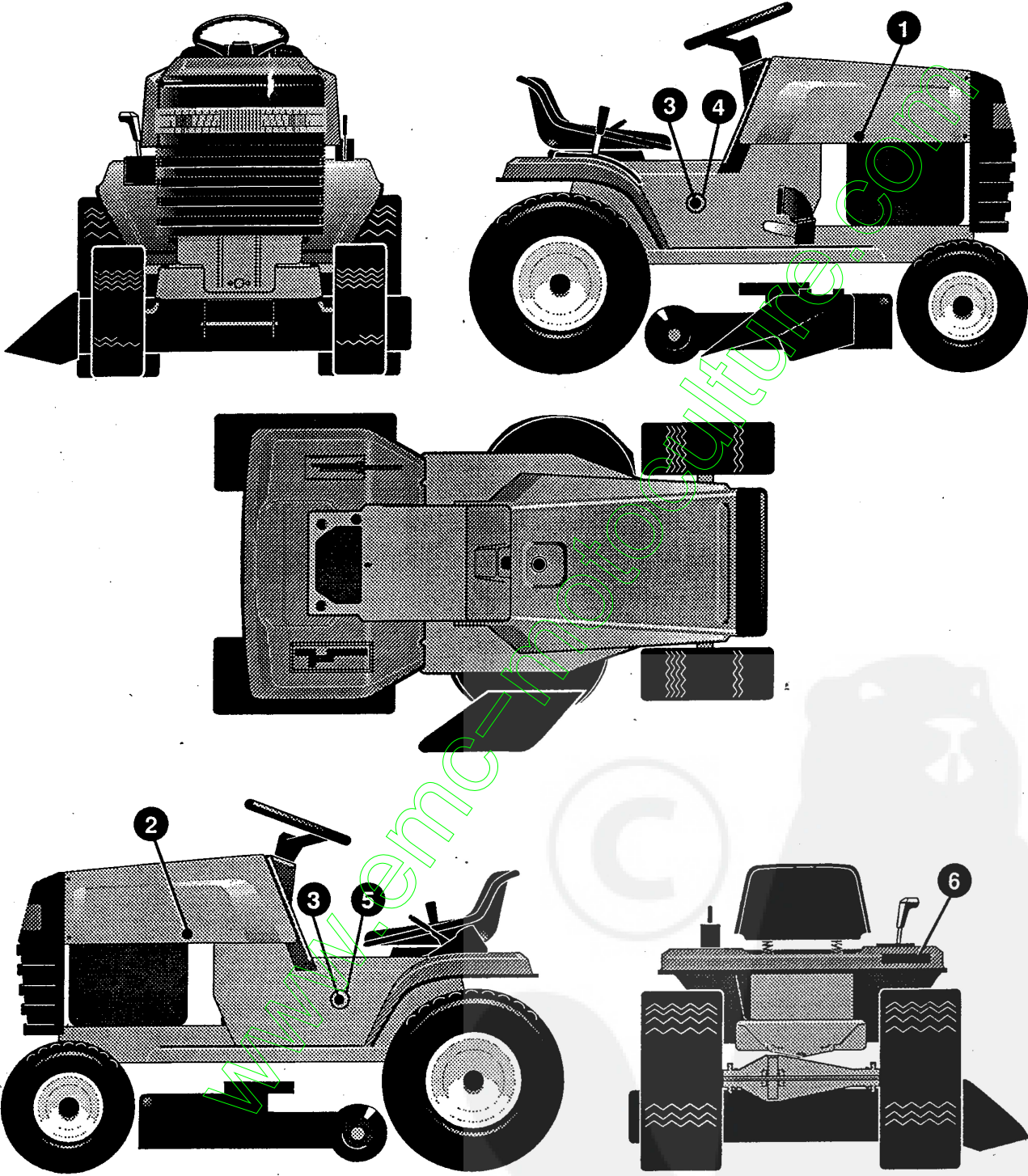

326825A

42" LAWN TRACTOR MODEL D3583-001

KEY#	PART#	DESCRIPTION	QTY.
1.	314456	DECAL, HOODSIDE RH H-21	1
2.	314457	DECAL, HOODSIDE LH H-21	1
3.	300561	NAME PLATE, 16/42	2
4.	314462	DECAL, CONSOLE RH LARGE FRAME	1
5.	314463	DECAL, CONSOLE LH LARGE FRAME	1
6.	320645	NAMEPLATE "AUTOMATIC"	1

www.emc-motoculture.com

42" LAWN TRACTOR MODEL D3583-001

DECALS (INSTRUCTIONAL)

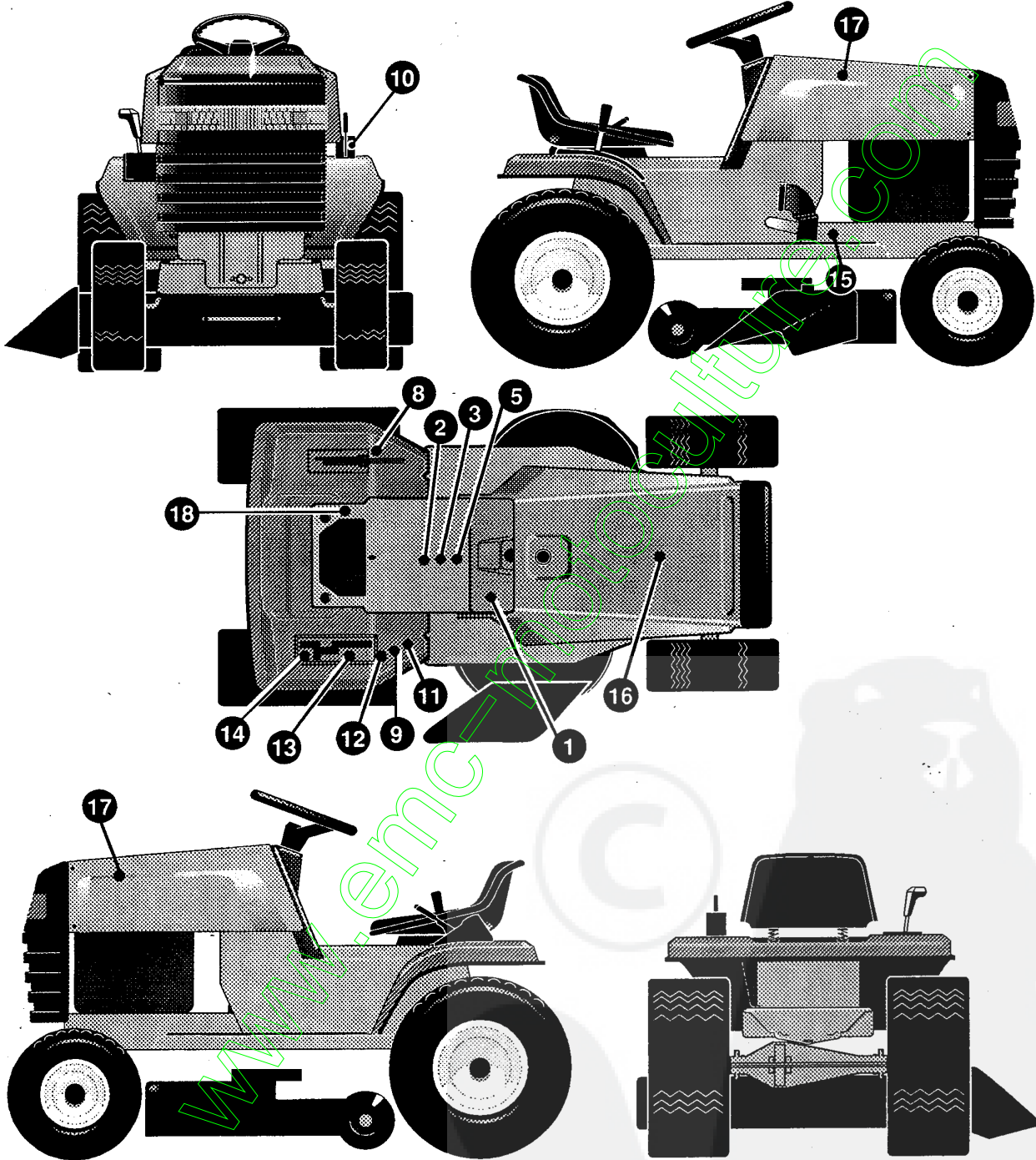

329619A

42" LAWN TRACTOR MODEL D3583-001

KEY#	PART#	DESCRIPTION	QTY.
1.	324534	DECAL, LF DASH LT. SW/CHOKE EXP.	1
2.	69524	DECAL,INSTRUCT CONSOLE TOP GER	1
3.	69525	DECAL,INSTRUCT CONSOLE TOP FR	1
4.		REFERENCE ONLY	1
5.	307383	DECAL,INSTR. CONSOLE TOP ENGL	1
6.		REFERENCE ONLY	1
7.		REFERENCE ONLY	1
8.	68901	DECAL,BLADE HEIGHT ADJ. EUROPE	1
9.	68902	DECAL,WARNING,FRENCH/GERMAN	1
10.	301897	DECAL, LIFT DECK BLADE HEIGHT	1
11.	305770	DECAL,CAUTION TRIANGLE EUROPE	1
12.	310553	DECAL,DANGER ENGLISH	1
13.	314923	DECAL SHIFTER LF HYDRO FORWARD	1
14.	314925	DECAL SHIFT LF HYDRO REVERSE	1
15.	68903	DECAL,BRAKE/CLUTCH EUROPE	1
16.	55835	PAD, FOAM HOOD TOP H-6/7	1
17.	55836	PAD, FOAM HOOD SIDE H-6/7	2
18.	316861	DECAL, RELIEF VALVE OPERATION	1

REPAIR PARTS

HYDROSTATIC PUMP

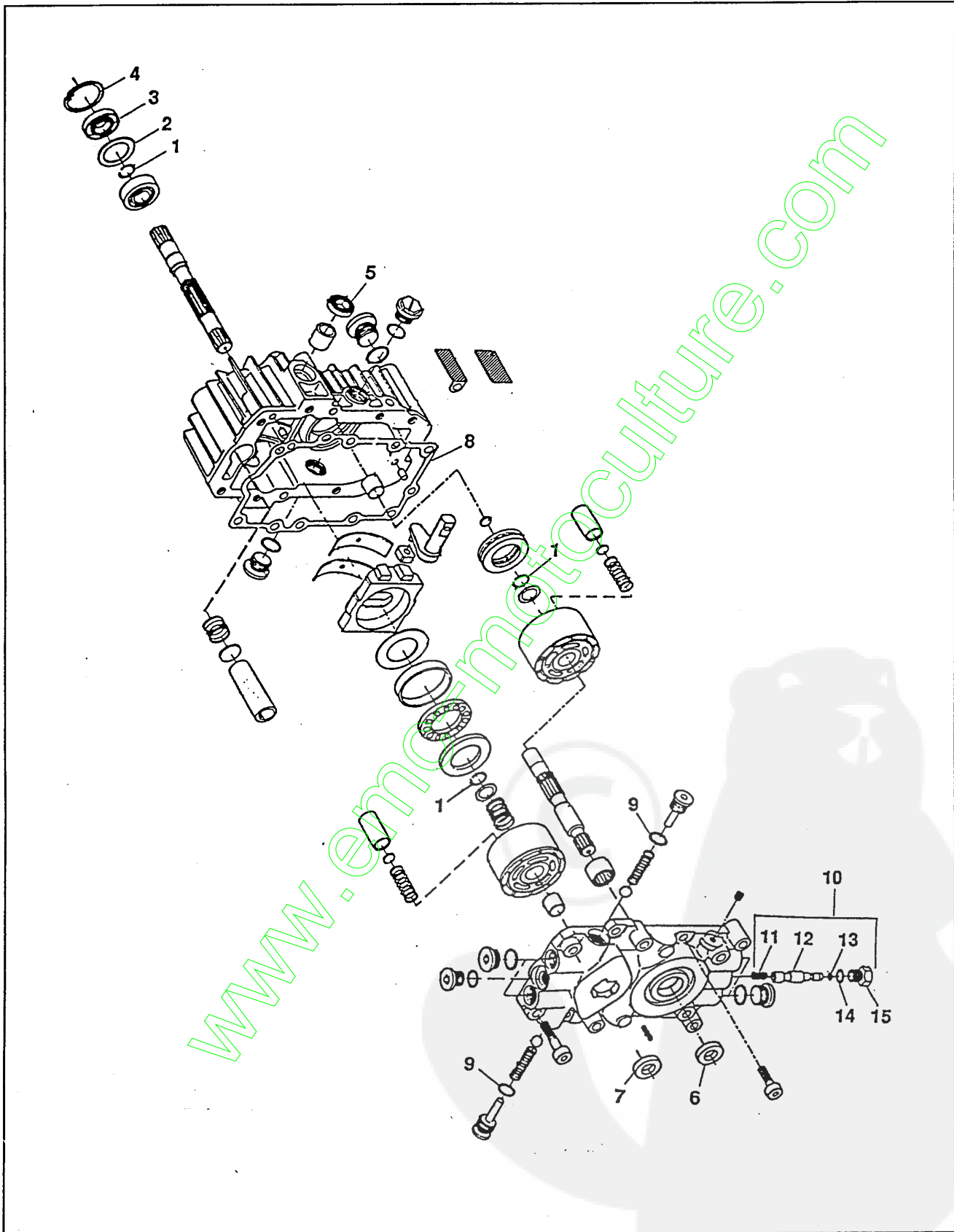

REPAIR PARTS

HYDROSTATIC PUMP

Key #	Part #	Description
	310227	HYDROSTATIC PUMP (COMPLETE)
	313306	OVERHAUL SEAL KIT (CONTAINS KEY NO.'S 1-9, 13 AND 14)
1		RING-RETAINING
2		SPACER
3		SEAL-LIP
4		RING-RETAINING
5		SEAL-LIP
6		SEAL-LIP
7		SEAL-LIP
8		GASKET-CENTER SECTION
9		O-RING
10	313305	BY-PASS VALVE KIT- COMPLETE (INCL. KEY NO.'S 11-15)
11		SPRING-HELICAL COMP
12		BY-PASS SPOOL
13		O-RING
14		O-RING
15		PLUG-BY-PASS

REPAIR PARTS

HYDROSTATIC TRANSAXLE

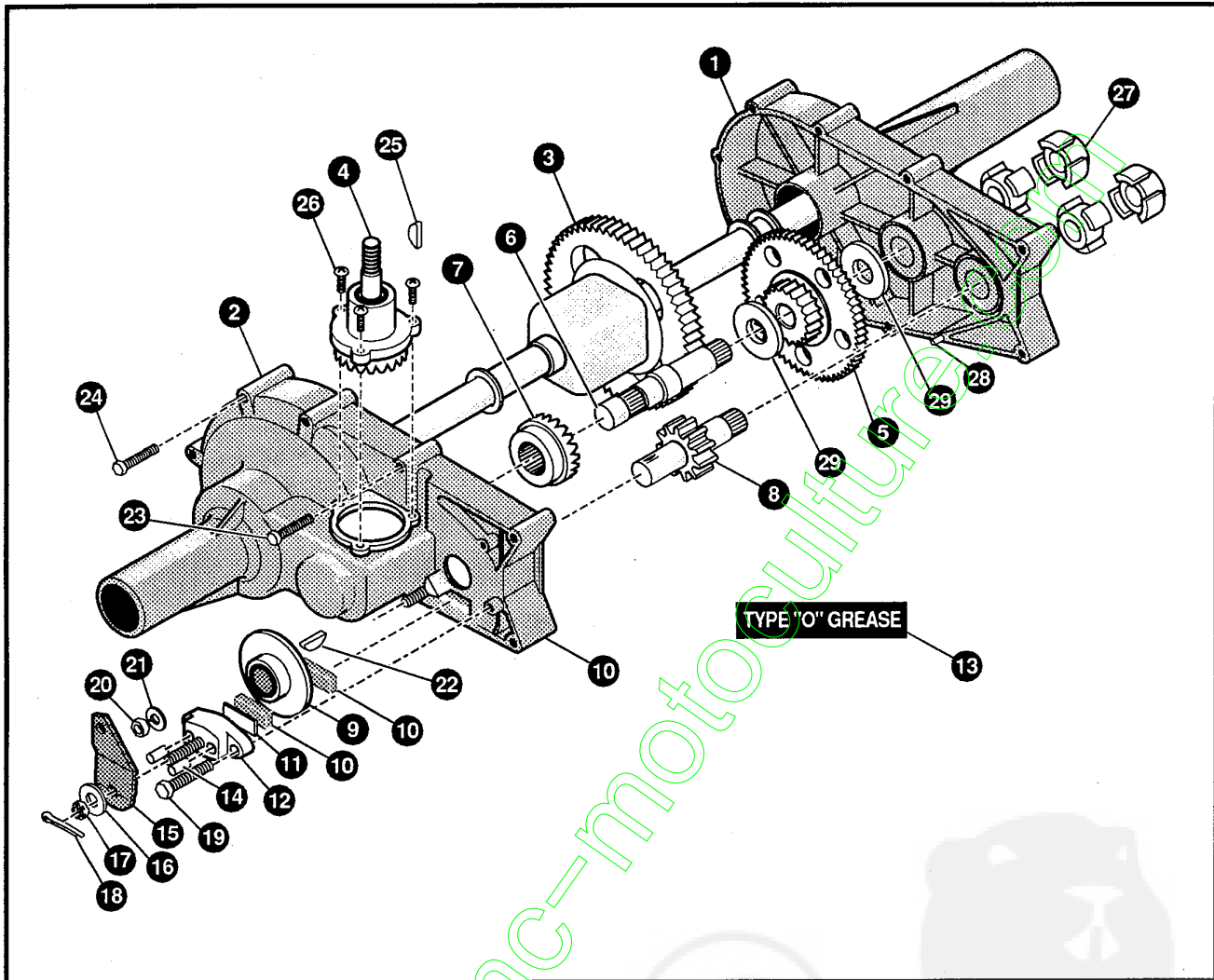

- | | | | |
|-----|----------------------|-----|---------------------|
| 1. | HOUSING HALF, LH | 16. | WASHER, FLAT |
| 2. | HOUSING HALF, RH | 17. | NUT, CASTLE |
| 3. | GEAR, DIFFERENTIAL | 18. | PIN, COTTER |
| 4. | SHAFT, INPUT | 19. | BOLT, HEX W/PATCH |
| 5. | GEAR | 20. | NUT, HEX |
| 6. | SHAFT, DRIVE | 21. | WASHER, SPRING LOCK |
| 7. | GEAR, DRIVE PINION | 22. | KEY, HI-PRO |
| 8. | SHAFT, PINION | 23. | BOLT, HEX SELF-TAP |
| 9. | DISC, BRAKE | 24. | BOLT, HEX SELF-TAP |
| 10. | PUCK, BRAKE | 25. | KEY, HI-PRO |
| 11. | PLATE, PUCK | 26. | SCREW, HEX W/PATCH |
| 12. | BRAKE, YOKE | 27. | COUPLING |
| 13. | TYPE "O" GREASE | 28. | PIN, ROLL |
| 14. | PIN, BRAKE ACTUATING | 29. | WASHER, FLAT |
| 15. | ARM, BRAKE ACTUATOR | | |

42" LAWN TRACTOR MODEL D3583-001

TREAD PATTERNS

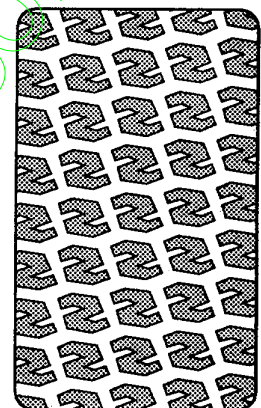
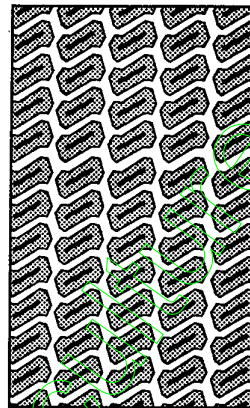
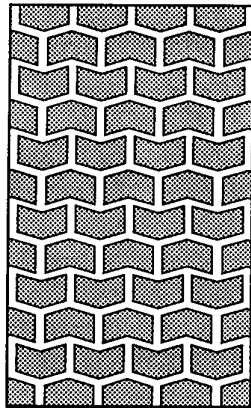
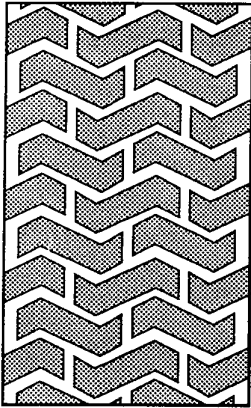

"A"

"B"

"C"

"D"

TIRE SIZE

	"A"	"B"	"C"	"D"
11 X 4.00 - 5	42295	319679		
13 X 5.00 - 6	41060	319680		
15 X 6.00 - 6	39830	316702	301140	313952
16 X 6.50 - 8	41081	319682		314539
18 X 8.50 - 8	319683	317400		
18 X 9.50 - 8	41106	316701		313950
20 X 8.00 - 8	319685	319684	57164	314584
20 X 10.00 - 8	58276	319686		313654
20 X 10.00 - 10	55893	319687		
23 X 9.50 - 12	53655	319690	319689	314370

ACCESSORIES

Contact the dealer where your tractor was purchased for the available accessories. If you are unable to contact the dealer, write to the address on the front cover of this manual.

Rear Engine Rider	
Model	Description
5708-16	Bagger - Fits 32" Side Discharge
5708-17	Bagger - Fits 36" Side Discharge & 30" Top Discharge
5709-02	Front Weight Box - holds 35 lbs.
5648-16	Lawn Sweeper w/dump Release
5714-00	Mulching Kit - 30" Top Discharge

Lawn Tractor	
Model	Description
5708-22	Bagger - Fits 30" Side Discharge
5708-13	Bagger - Fits 36", 38", 39" & 45" Side Discharge
5705-04	36" Two-Stage Snowblower - Fits 36", 38", 39", & 45" Side Discharge
5661-06	42" Snowblade - Fits 36", 38", 39", & 45"
5592-00	Tire Chains - 18" x 6.50"
5585-00	Tire Chains - 18" x 9.50" & 20" x 8"
5672-01	Wheel Weights - Front - 1 pr. w/mtg. hdw. - Fits 15" tires
5673-02	Wheel Weights - Rear - 1 pr. w/mtg. hdw. - Fits 18" & 20" tires
5709-03	Front Weights - Fits 30" & 32" Side Discharge
5648-16	Lawn Sweeper w/dump Release
5714-00	Mulching Kit - 30" Top Discharge

Garden Tractor - Light Ground Engaging	
Model	Description
5708-13	Bagger - Fits 36", 38", 39", & 45" Side Discharge
5705-04	36" Two - Stage Snowblower - Fits 36", 38", 39", & 45"
5661-06	42" Snowblade - Fits 36", 38", 39", & 45"
5672-01	Wheel Weights - Front 1 pr. w/mtg. hdw. - Fits 15" tires
5673-02	Wheel Weights - Rear - 1 pr. w/mtg. hdw. - Fits 18" & 20" tires
5648-16	Lawn Sweeper w/dump Release
5667-02	Sleeve Hitch - w/lift bar - Fits 45"
5668-01	Adaptor (sleeve hitch) for use w/23" tires
5706-00	Tire Chains - 20" x 10"
5671-00	Tire Chains - 23" x 9.50"
5672-02	Wheel Weights - Front - 1 pr. w/mtg. hdw. Fits 16" tires
5673-00	Wheel Weights - Rear - 1 pr. w/mtg. hdw. Fits 23" tires
5674-01*	10" One Bottom Moldboard Plow
5675-01*	Cultivator - 7 row - Adj. 6" - 42" width
5676-01*	Disc Harrow - 8" & 11" disc - Adj. width & disc angle
5677-02*	Tiller - 5 H.P. Self-Powered - 28" width

Four Wheel Steer	
Model	Description
5708-14	Bagger - Fits 40" & 46" Side Discharge
5705-05	42" One-Stage Snowblower - Fits 40" & 46"
5661-07	48" Snowblade - Fits 40" & 46"
5709-04	Rear Weight Box for 40" & 46"
5648-16	Lawn Sweeper w/dump Release
5706-00	Tire Chains 20" x 10"
5671-00	Tire Chains 23" x 9.50"
5672-02	Wheel Weights - Front - 1 pr. w/mtg. hdw. Fits 16" tires
5673-00	Wheel Weights - Rear - 1 pr. w/mtg. hdw. Fits 23" tires
5672-01	Wheel Weights - Front - 1 pr. w/mtg. hdw. Fits 15" tires
5673-02	Wheel Weights - Rear - 1 pr. w/mtg. hdw. Fits 18" & 20" tires

Two Wheel Steer Garden Tractor	
Model	Description
5667-04	Sleeve Hitch - w/lift bar Fits 46"
5674-01*	10" One Bottom Moldboard Plow
5675-01*	Cultivator - 7 row - Adj. 6" - 42" width
5676-01*	Disc Harrow 8" & 11" Disc. Adj. width & disc angle
5677-02*	Tiller 5 H.P. Self-Powered - 28" width
5648-16	Lawn Sweeper w/dump Release

*Requires a sleeve hitch