



# Parts Manual

Mfg. No: 7800319  
385048x151, Lawn Tractor (2008)



---

<b>Model Components</b>	<b>Page</b>
Chassis & Hood.....	4
Decals.....	8
Electrical System.....	10
Engine Mount.....	12
Motion Drive.....	14
Mower Housing.....	18
Mower Housing Suspension.....	22
Steering.....	24
Torque Specification Chart.....	26

Not For  
In Reproduction

# Chassis & Hood

Note: Unless noted otherwise, use the standard torque specifications

Mfg. No: 7800319

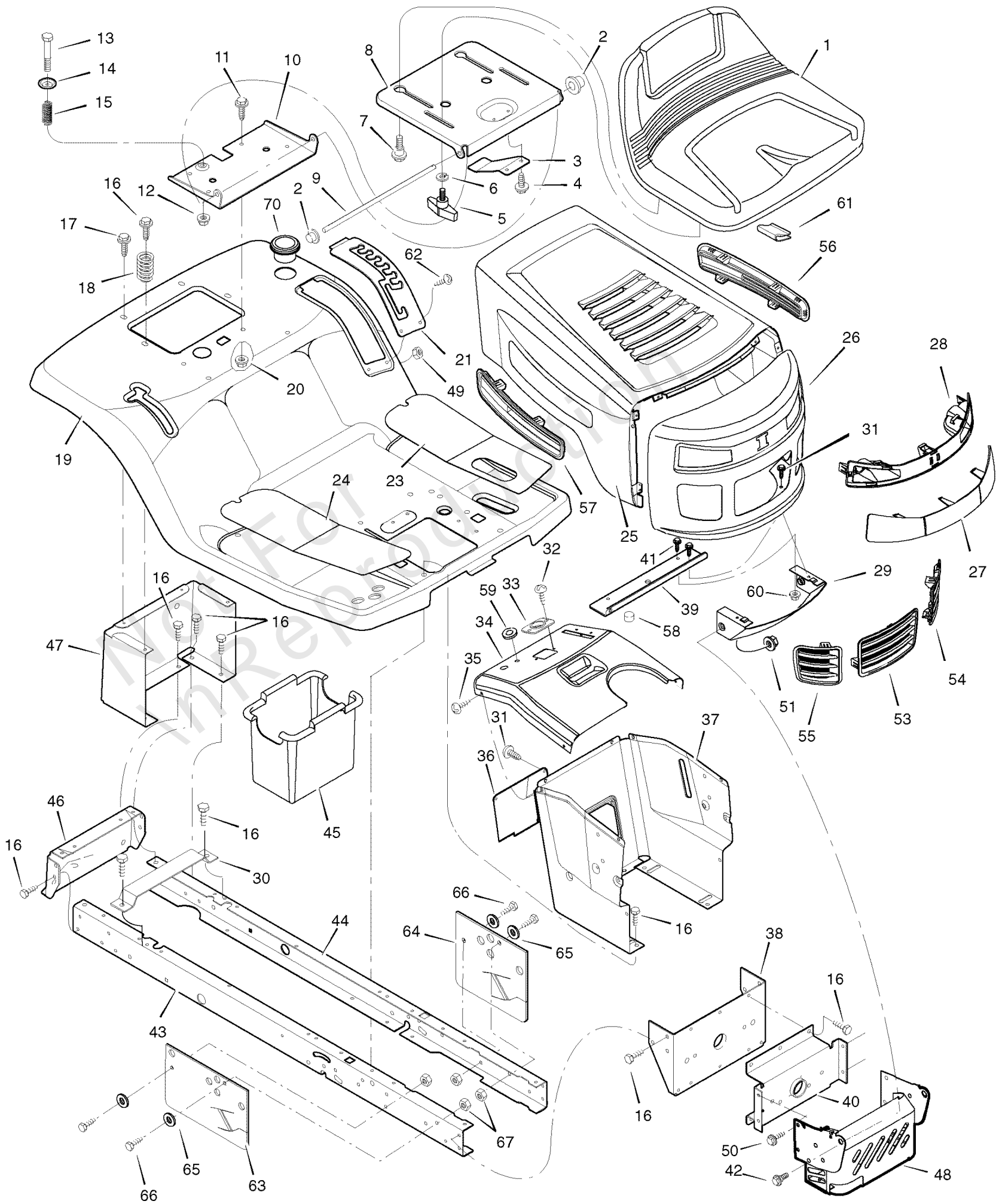

## Chassis & Hood

REF NO	PART NO	QTY	DESCRIPTION
1	094161MA		SEAT
2	028X23MA		CAP, Push On
3	094057MA		SPRING
4	26X229MA		SCREW
5	1001054MA		BOLT, Wing
6	017X47MA		WASHER
7	009X56MA		BOLT, Shoulder
8	7300875ZMA		SUPPORT, Seat
9	094156ZMA		ROD, Pivot
10	7300794ZMA		BRACKET, Pivot
11	001X45MA		BOLT
12	015X89MA		NUT
13	009X55MA		BOLT, Shoulder
14	094155ZMA		WASHER
15	164X31MA		SPRING
16	26X249MA		SCREW
17	26X263MA		SCREW
18	164X30MA		SPRING
19	7300843ZMA		DECK, Seat
20	15X123MA		NUT
21	7300839ZMA		PLATE, Index
23	094999MA		MAT, Left
24	094998MA		MAT, Right
25	7300786ZMA		HOOD, WM1
26	7300778ZMA		GRILLE
27	1001806MA		LENS
28	1001805MA		HOUSING, Headlamp
29	1740530ZMA		BRACKET, Lower Pivot
30	7300741ZMA		SUPPORT, Battery
31	26X270MA		SCREW
32	26X238MA		SCREW
33	1001491MA		BEARING, Steering
34	7300774TMA		DASH
35	26X201MA		SCREW
36	7300750TMA		PANEL, Access
37	7300872TMA		SUPPORT, Dash
38	7300751ZMA		BRACKET, Rear Hanger
39	1740529MA		BRACKET, Support
40	7300742ZMA		AXLE, Hanger
41	26X263MA		SCREW
42	009X58MA		BOLT, Shoulder
43	7300870ZMA		FRAME, Right
44	7300869ZMA		FRAME, Left
45	690424MA		CONTAINER, Battery
46	7300864ZMA		PLATE, Hitch
47	7300832ZMA		PANEL, Rear
48	1740501AYP		SHIELD, Heat
49	015X81MA		NUT
50	26X277MA		SCREW
51	7091619SM		NUT
53	1741762MA		INSERT, Center Grille

# Chassis & Hood

Note: Unless noted otherwise, use the standard torque specifications

Mfg. No: 7800319

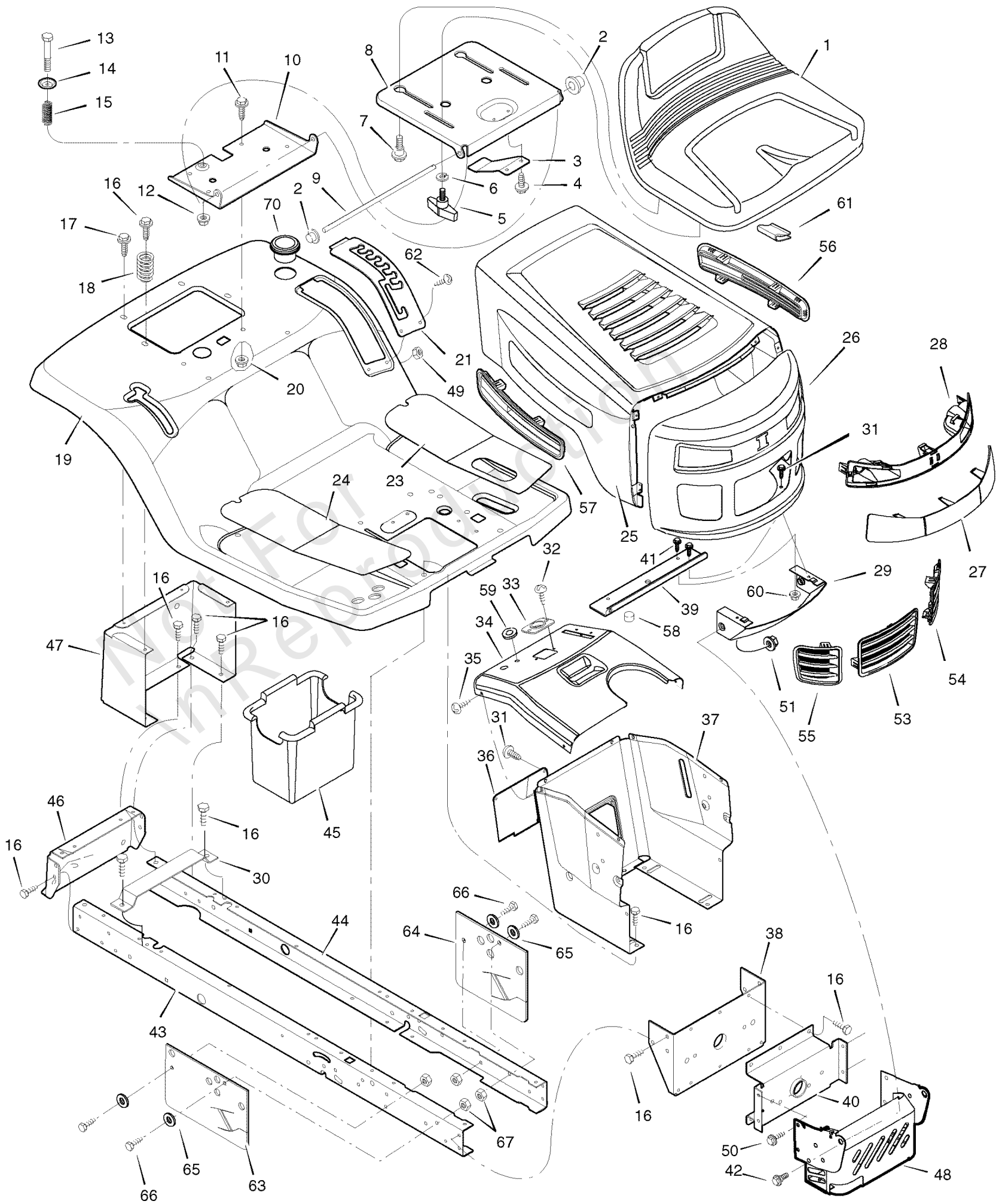

## Chassis & Hood

REF NO	PART NO	QTY	DESCRIPTION
54	1741763MA		INSERT, Left Grille
55	1741764MA		INSERT, Right Grille
56	1741760MA		INSERT, Left Hood
57	1741761MA		INSERT, Right Hood
58	094376MA		BUMPER
59	1001755MA		GROMMET, Parking Brake
60	015X82MA		NUT
61	028X83MA		S-CLIP, Black
62	009X49MA		BOLT
63	1735615MA		GUARD, Rubber, RH, Black
64	1735621MA		GUARD, Rubber, LH, Black
65	017X45MA		WASHER
66	001X84MA		CAPSCREW, Hex Head, 5/16-18 x 1
67	15X123MA		NUT, Hexlock
70	1741770MA		HOLDER, Cup
--	1002050MA		PARTS BAG, Assembly
--	7101958		MANUAL, Parts List
--	7101957		INSTRUCTION BOOK

# Decals

Note: Unless noted otherwise, use the standard torque specifications

Mfg. No: 7800319

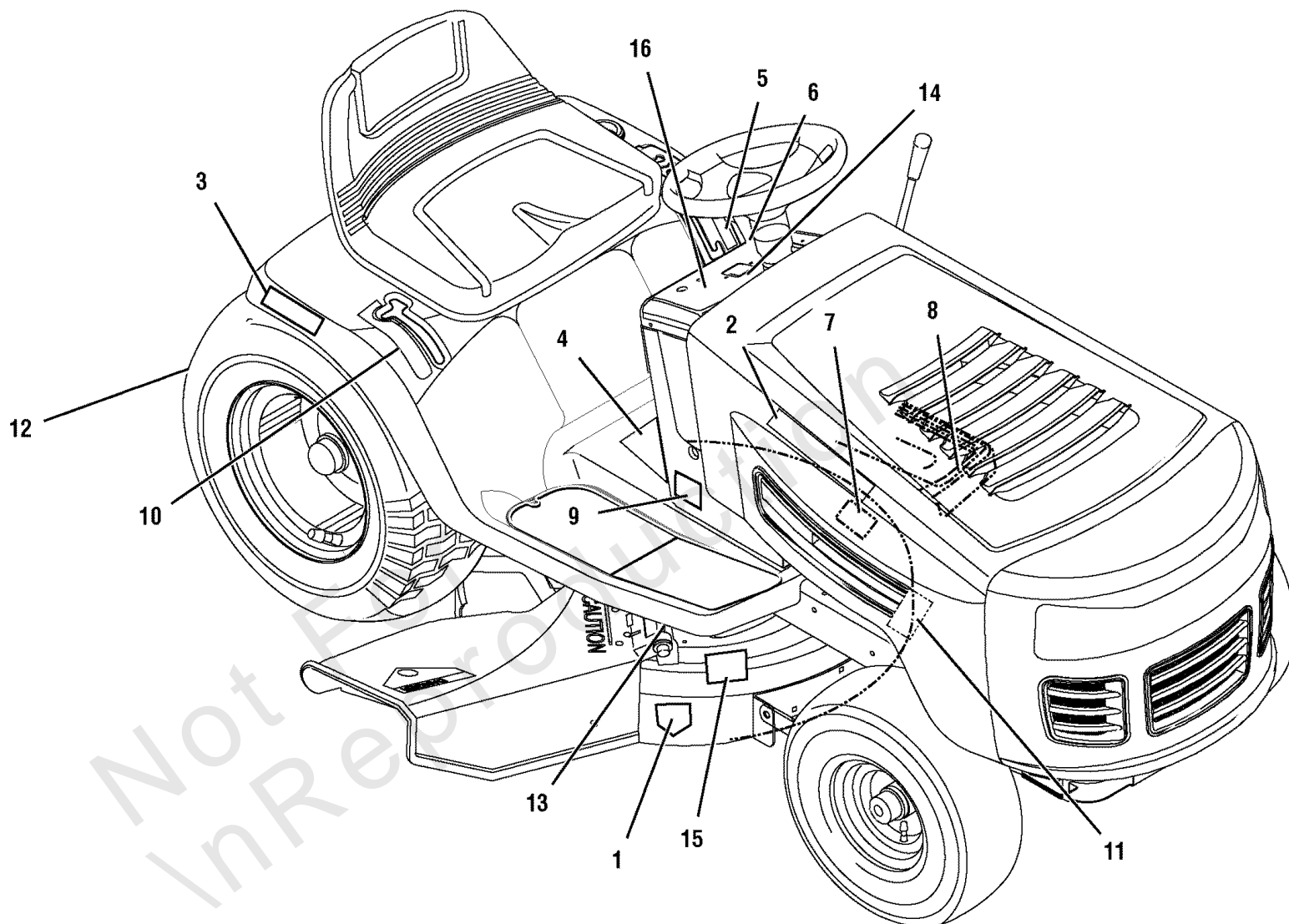



## Decals

REF NO	PART NO	QTY	DESCRIPTION
1	48X4033MA	1	DECAL, Cut Finger Symbols
2	1740552MA	2	DECAL, Murray R.H. & L.H.
3	7101905MA	2	DECAL, 125/96 R.H. & L.H.
4	48X4032MA	1	DECAL, Warning Export
5	44X7026MA	1	DECAL, 7 Position Cut Height
6	44X7027MA	1	DECAL, Deck Level
7	48X4034MA	1	DECAL, No Step Export
8	44X5437MA	1	DECAL, Brake/Clutch Export
9	44X6277MA	1	DECAL, B&S Logo
10	48X5451MA	1	DECAL, 5 Speed
11	44X5936MA	1	DECAL, Heat Shield Warning
12	48X511MA	1	DECAL, Warning Load Limit Export
13	44X6828MA	1	DECAL, Warning Pinch Point
14	44X6817MA	1	DECAL, Dash/Symbols X-W Styles
15	48X5911MA	1	DECAL, 100db Export
16	44X6595MA	1	DECAL, Gas Gauge

# Electrical System

Note: Unless noted otherwise, use the standard torque specifications

Mfg. No: 7800319

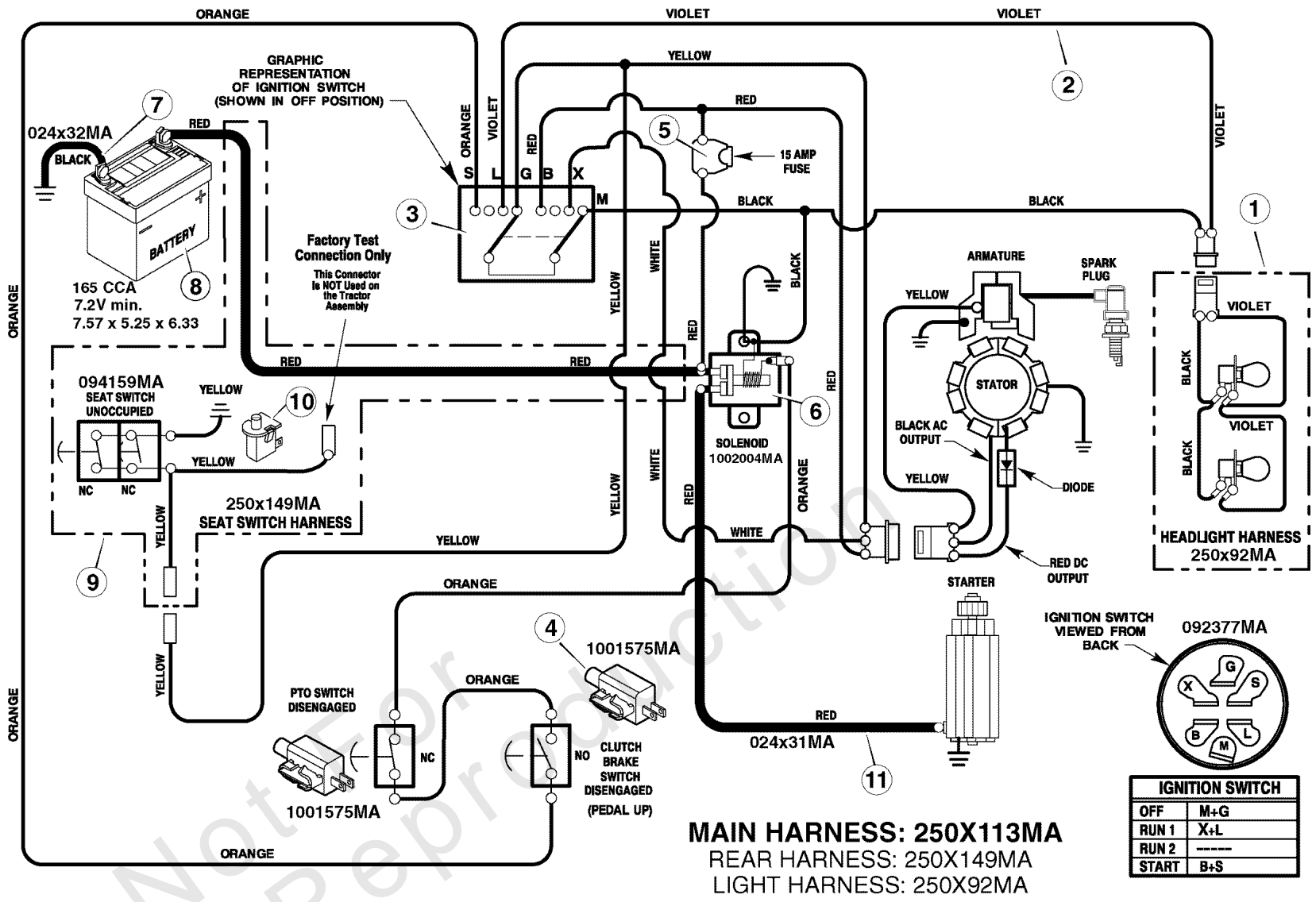

## Electrical System

REF NO	PART NO	QTY	DESCRIPTION
1	250X92MA		HARNESS, Light Wire
--	1001716MA		SOCKET, Light
--	090084MA		BULB, Light
2	250X113MA		HARNESS, Chassis Wire
3	092377MA		SWITCH, Ignition
--	020729MA		KEY, Ignition
--	091489MA		NUT, Hex
--	091488MA		CAP, Ignition
4	1001575MA		SWITCH, Limit
5	302031MA		FUSE
--	407078MA		HOLDER, Fuse
6	1002004MA		SOLENOID
--	26X229MA		SCREW, Mounting
--	15X116MA		LOCKNUT
7	024X32MA		CABLE, Battery Ground
--	26X229MA		SCREW, Ground Cable
8	-----		BATTERY -165 CCA 7.2V min. 7.57 x 5.25 x 6.33
--	002X82MA		BOLT, Carriage
--	014X79MA		WINGNUT
--	690604MA		BOOT, Battery Terminal, Positive
9	250X149MA		HARNESS, Seat Switch Wire
10	094159MA		SWITCH, Seat Sensor
11	024X31MA		CABLE

# Engine Mount

Note: Unless noted otherwise, use the standard torque specifications

Mfg. No: 7800319

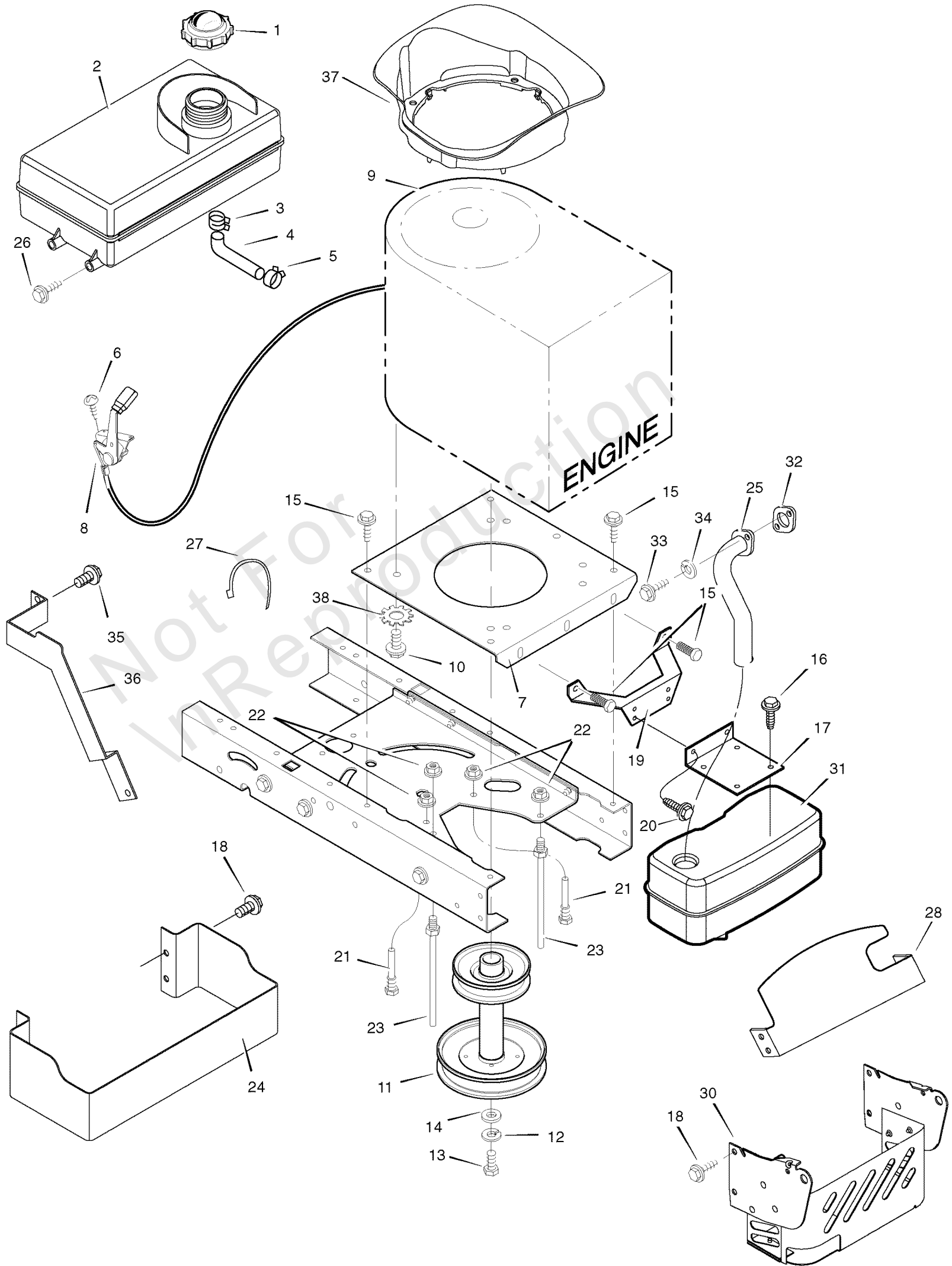

## Engine Mount

REF NO	PART NO	QTY	DESCRIPTION
1	092317MA		Fuel Cap -(Included with Ref. No. 2)
2	7601092MA		TANK, Fuel 1.4 Gal.
3	095197MA		Hose Clamp
4	7601033MA		Fuel Line (Must cut to length)
5	095197MA		Hose Clamp
6	26X201MA		SCREW
7	7300863ZMA		PLATE, Engine
8	092371MA		THROTTLE CONTROL
9	-----		Engine, Briggs & Stratton * -(Model: 2198070150B1)
10	0025X7MA		BOLT, Engine Mount
11	690439MA		STACK PULLEY ASSEMBLY
12	019X35MA		LOCKWASHER
13	01X140MA		BOLT, Hex
14	17X170MA		WASHER
15	26X249MA		SCREW
16	26X229MA		SCREW
17	7300760AMA		BRACKET, Muffler
18	26X277MA		SCREW
19	7300817ZMA		BRACKET, Muffler Mount
20	26X213MA		SCREW
21	094384MA		GUIDE, Belt
22	7090585MA		NUT, Flange
23	094066MA		GUIDE, Belt
24	7300783AMA		GUARD, Heat Shield
25	1001747MA		EXHAUST TUBE, Single
26	26X253MA		SCREW
27	032618MA		TIE, Strap, 5.38 Long
28	1740502AMA		GUARD, Heat Shield, Upper
30	1740501AYP		SHIELD, Heat
31	094654MA		MUFFLER
32	692236		GASKET, Exhaust
33	06X103MA		SCREW
34	018X15MA		WASHER
35	06X104MA		BOLT, Washer Hex Head
36	1740504AMA		GUARD, Exhaust Pipe
37	1740503MA		PLENUM, X1 M28/31
38	0019X8MA		WASHER, Star .38 0.68X

### Footnotes:

Note\* For information on Replacement Parts for this engine contact the manufacturer.



## Motion Drive

REF NO	PART NO	QTY	DESCRIPTION
1	009X39MA		BOLT, Shoulder
2	015X89MA		NUT, Hex
3	7400241MA		ARM, Idler
4	094041ZMA		ROD, Clutch
5	7090585MA		NUT
6	17X102MA		WASHER
7	1741756MA		GRIP
8	030X20MA		PIN, Cotter
9	094043ZMA		LEVER, Shift
10	017X47MA		WASHER
11	094044ZMA		LINK, Shift
12	021920ZMA		NUT, Adjuster
13	1741757MA		GRIP
14	1001245ZMA		ROD, Parking Brake
15	094815ZMA		NUT, Adjuster
16	1001303ZMA		BRACKET, Shift Pivot
17	26X249MA		SCREW
18	015X84MA		NUT
19	094042ZMA		MOUNT, Stud Spring
20	009X54MA		BOLT, Shoulder
21	165X116MA		SPRING, Extension
22	7300824ZMA		BRACKET, Right Shifter
23	7300870ZMA		FRAME, Right
24	002X53MA		BOLT, Carriage
25	7300869ZMA		FRAME, Left
26	094045ZMA		LATCH, Parking Brake
27	021544MA		PEDAL
28	7400256ZMA		LEVER, Brake/Clutch
29	1001117E701MA		BRACKET, Pedal
30	7101749MA		BELT, Motion Drive
31	094031ZMA		YOKE, Shift
32	0031X6MA		PIN, Hair
33	017X38MA		WASHER
34	690369MA		SPACER
35	06X105MA		BOLT
36	-----		Transaxle **
37	015X88MA		NUT
38	020697MA		KEY, Woodruff
39	01X155MA		BOLT
40	7300769ZMA		BRACKET, Transaxle
41	690409MA		PULLEY
42	7300845ZMA		BRACKET, Torque Strap, LH
43	0011X7MA		RING RETAINER
44	095094MA		PULLEY Drive
45	021553MA		KEY, Square
46	17X160MA		WASHER
47	1401103MA		SPACER, Transaxle
48	024373MA		STEM, Valve

### Footnotes:

Note\* When you order a tire, make sure to give the brand name of the tire so that the tread pattern on the tire will match.

Note\*\* For Replacement Parts see the Transaxle manufacturer.

# Motion Drive

Note: Unless noted otherwise, use the standard torque specifications

Mfg. No: 7800319

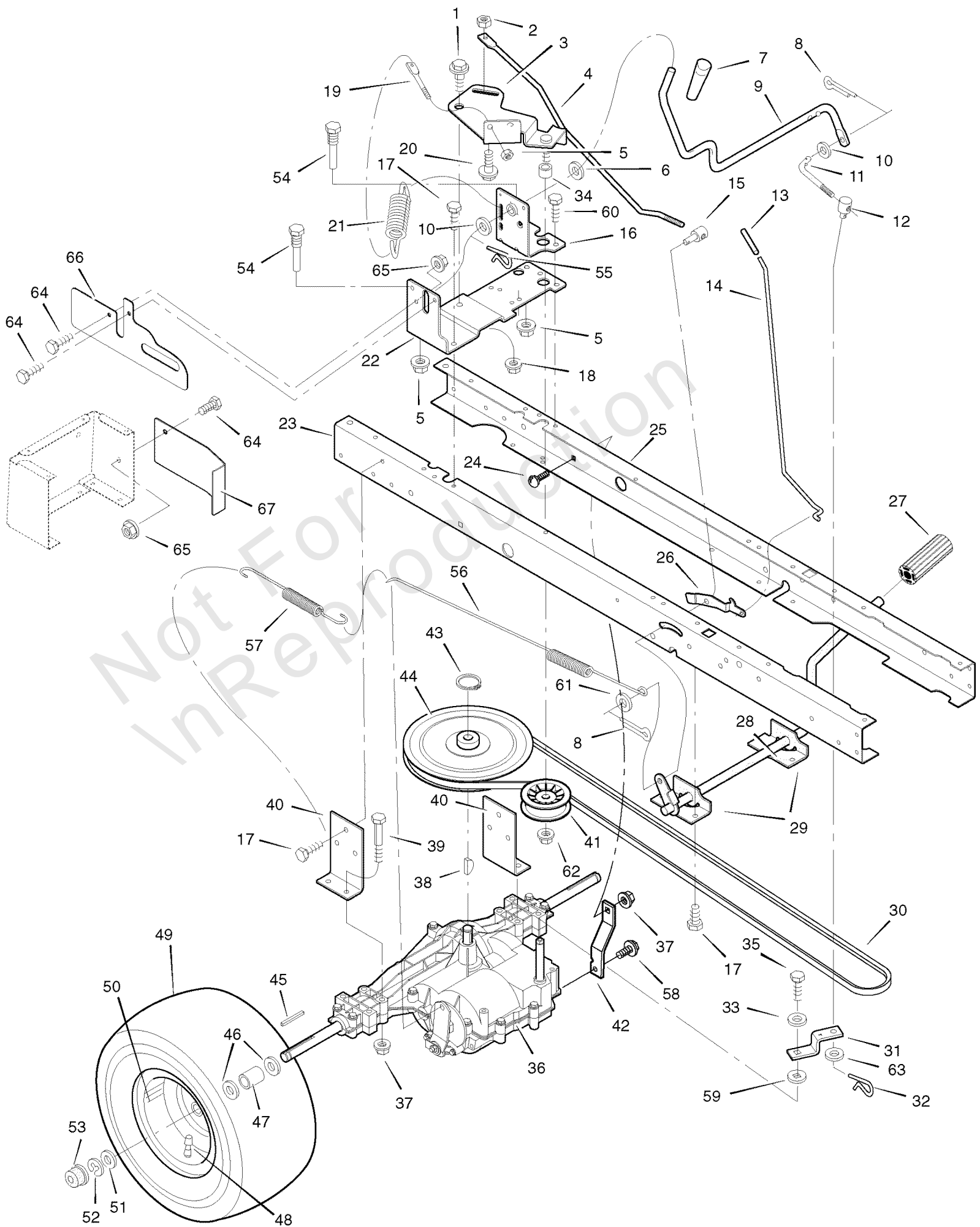



## Motion Drive

REF NO	PART NO	QTY	DESCRIPTION
49	091923MA		Tire *
--	407049MA		TUBE -(Not Illustrated)
50	092288601MA		WHEEL & TIRE ASSEMBLY
51	17X195MA		WASHER
52	0011X3MA		E-Ring
53	094618MA		HUB CAP
54	093349MA		GUIDE, Belt
55	0031X4MA		PIN, Hair
56	165X115MA		SPRING, Extension
57	165X92MA		SPRING, Extension
58	26X216MA		SCREW
59	17X148MA		WASHER
60	26X267MA		SCREW
61	17X169MA		WASHER
62	015X98MA		NUT, Hex
63	017X45MA		WASHER
64	01X121MA		CAPSCREW, Hex Head, 1/4-20 x 3/4
65	015X82MA		NUT, Hex Flange, 1/4-20
66	1735564ZMA		GUARD PLATE, RH, GEAR DRIVE
67	1735563ZMA		GUARD PLATE, LH, GEAR DRIVE

---

**Footnotes:**

Note\* When you order a tire, make sure to give the brand name of the tire so that the tread pattern on the tire will match.

Note\*\* For Replacement Parts see the Transaxle manufacturer.

# Mower Housing

Note: Unless noted otherwise, use the standard torque specifications

Mfg. No: 7800319

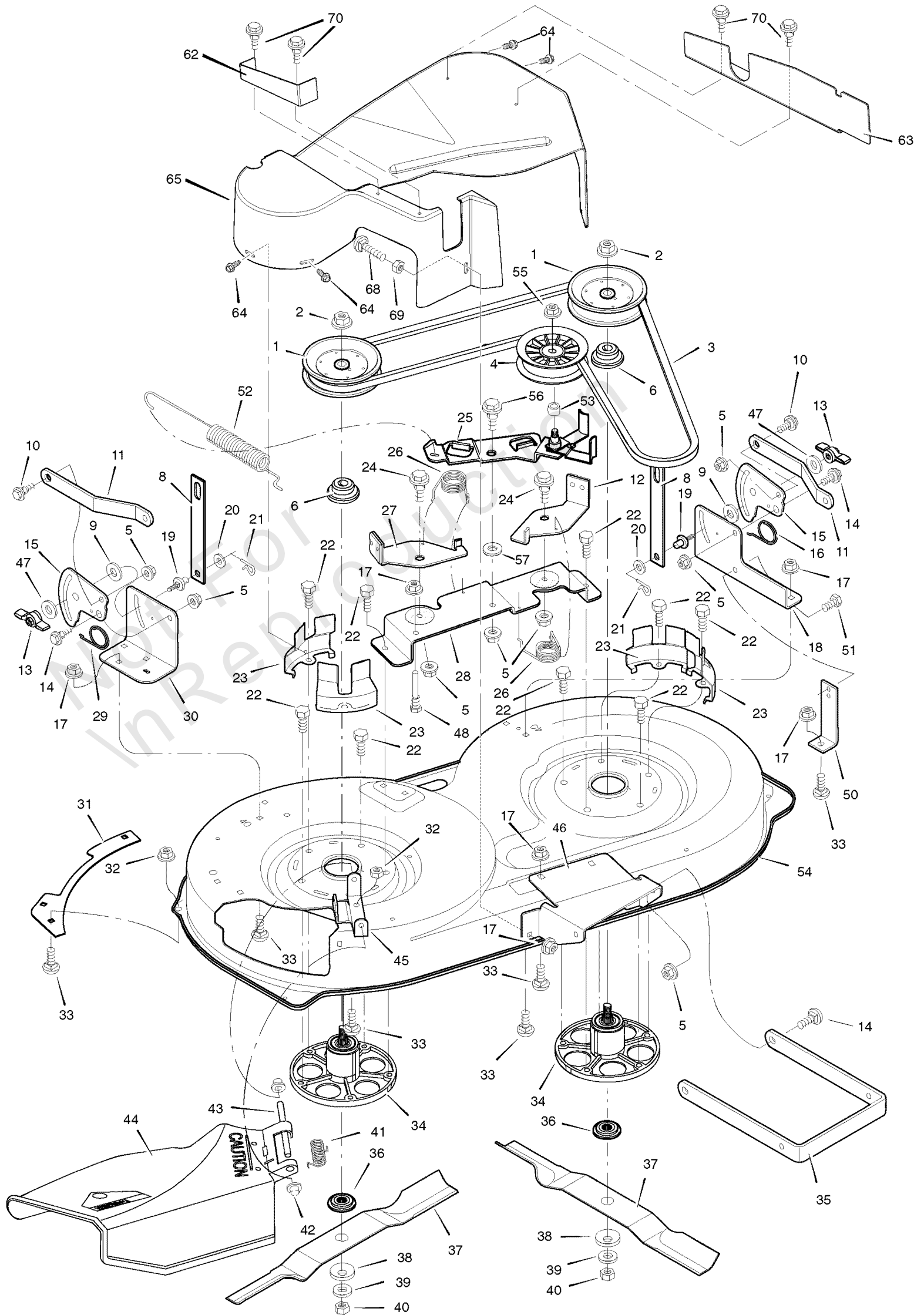

## Mower Housing

REF NO	PART NO	QTY	DESCRIPTION
1	092852MA		PULLEY, Jackshaft
2	15X140MA		NUT, Hex
3	037X86MA		BELT, Mower Drive
4	091801MA		PULLEY, Idler
5	015X84MA		NUT, Flange
6	1001197MA		SPACER, Pulley -(Included with Ref. No. 34)
8	7300749ZMA		LINK, Lift
9	094137MA		PAD, Friction
10	009X52MA		BOLT, Shoulder
11	7300826ZMA		BRACKET, Suspension
12	094049E701MA		PAD ASSEMBLY, Left Brake
13	094068MA		KNOB
14	009X51MA		BOLT, Shoulder
15	7300878ZMA		PLATE, Suspension
16	166X43MA		SPRING
17	7090585MA		NUT, Flange
18	7500703ZYP		BRACKET, Left Suspension
19	095194MA		PIN, Hanger
20	017X91MA		WASHER
21	0031X4MA		PIN, Cotter
22	0025X6MA		BOLT
23	7300859ZMA		GUIDE, Belt
24	009X39MA		BOLT, Shoulder
25	1001499MA		ARM, Idler
26	166X41MA		SPRING
27	7400243ZMA		PAD ASSEMBLY, Right Brake
28	7300732ZMA		BRACKET ASSEMBLY, Brake
29	166X42MA		SPRING
30	7300738ZMA		BRACKET, Right Suspension
31	7300834ZMA		PLATE
32	015X88MA		NUT, Flange
33	002X53MA		BOLT, Carriage
34	1001200MA		MANDRELL -(Includes Ref. No. 6)
35	7300767ZMA		BRACKET, Suspension
36	690411MA		ADAPTER, Blade
37	7101751AMA		BLADE
38	17X166MA		WASHER
39	17X165MA		WASHER
40	15X100MA		NUT
41	0166X4MA		SPRING
42	028X23MA		CAP, Push On
43	094957ZMA		ROD, Deflector
44	094707MA		DEFLECTOR ASSEMBLY
45	7300812ZMA		BRACKET, Deflector
46	7300734ZMA		BRACKET, Front Hanger
47	017X45MA		WASHER
48	094781MA		GUIDE, Belt
50	7300766ZMA		BRACKET, Support
51	26X249MA		SCREW
52	165X118MA		SPRING, Extension

# Mower Housing

Note: Unless noted otherwise, use the standard torque specifications

Mfg. No: 7800319

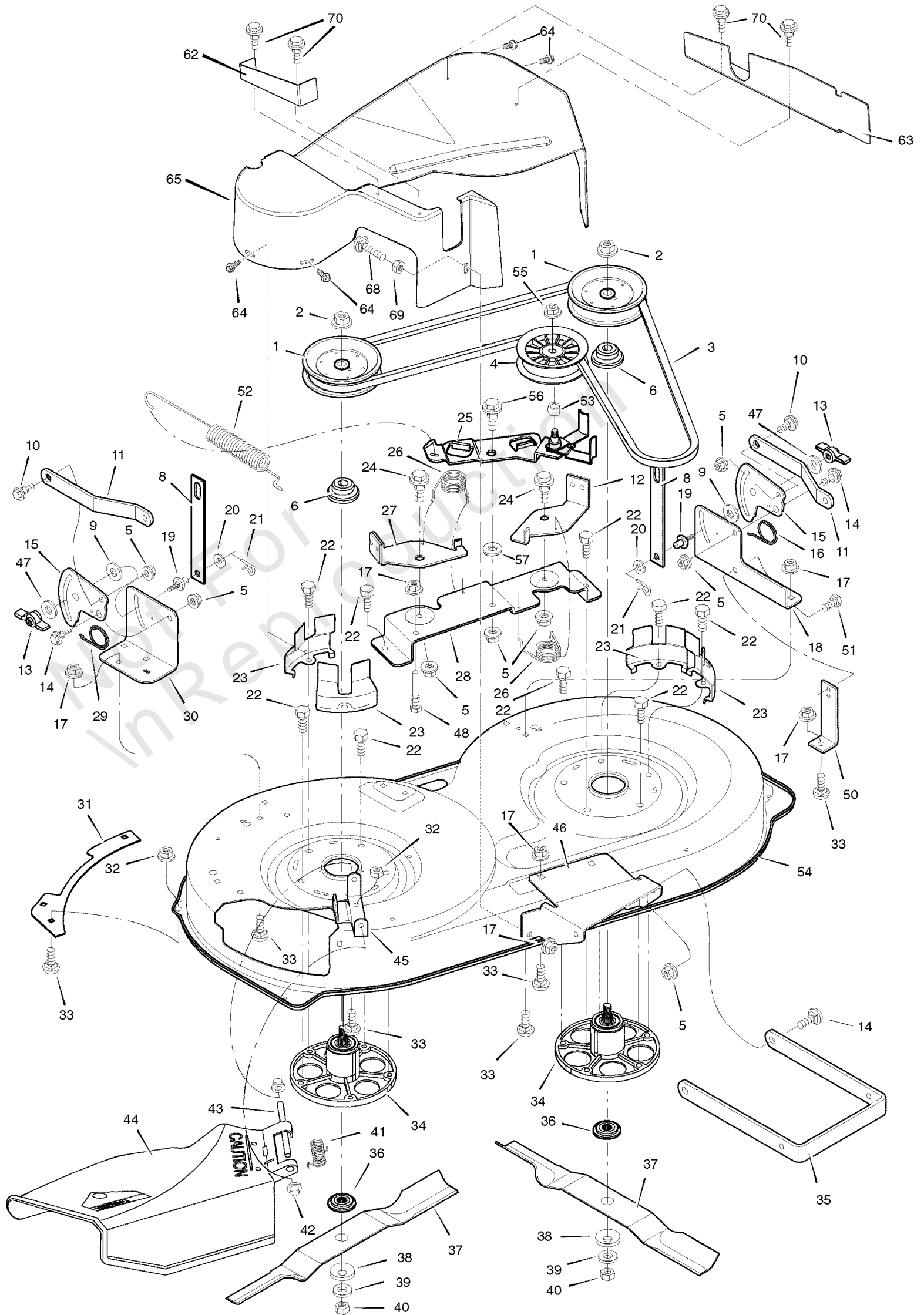

## Mower Housing

REF NO	PART NO	QTY	DESCRIPTION
53	690369MA		SPACER
54	7300788ZMA		HOUSING, Export Blade
55	015X98MA		NUT, Flange
56	009X72MA		BOLT, Shoulder
57	17X174ZMA		WASHER
62	1735614ZMA		PLATE, Guard 38" RH
63	1735566ZMA		PLATE, Guard 38" LH
64	26X263MA		SCREW
65	1735560MA		COVER, Guard
68	002X81MA		BOLT, Carriage, 5/16-18 x 1.50
69	15X123MA		NUT, Hex Lock 3/8-18
70	26X214MA		SCREW HEXHEAD TAP

Not For InReproduction

# Mower Housing Suspension

Note: Unless noted otherwise, use the standard torque specifications

Mfg. No: 7800319

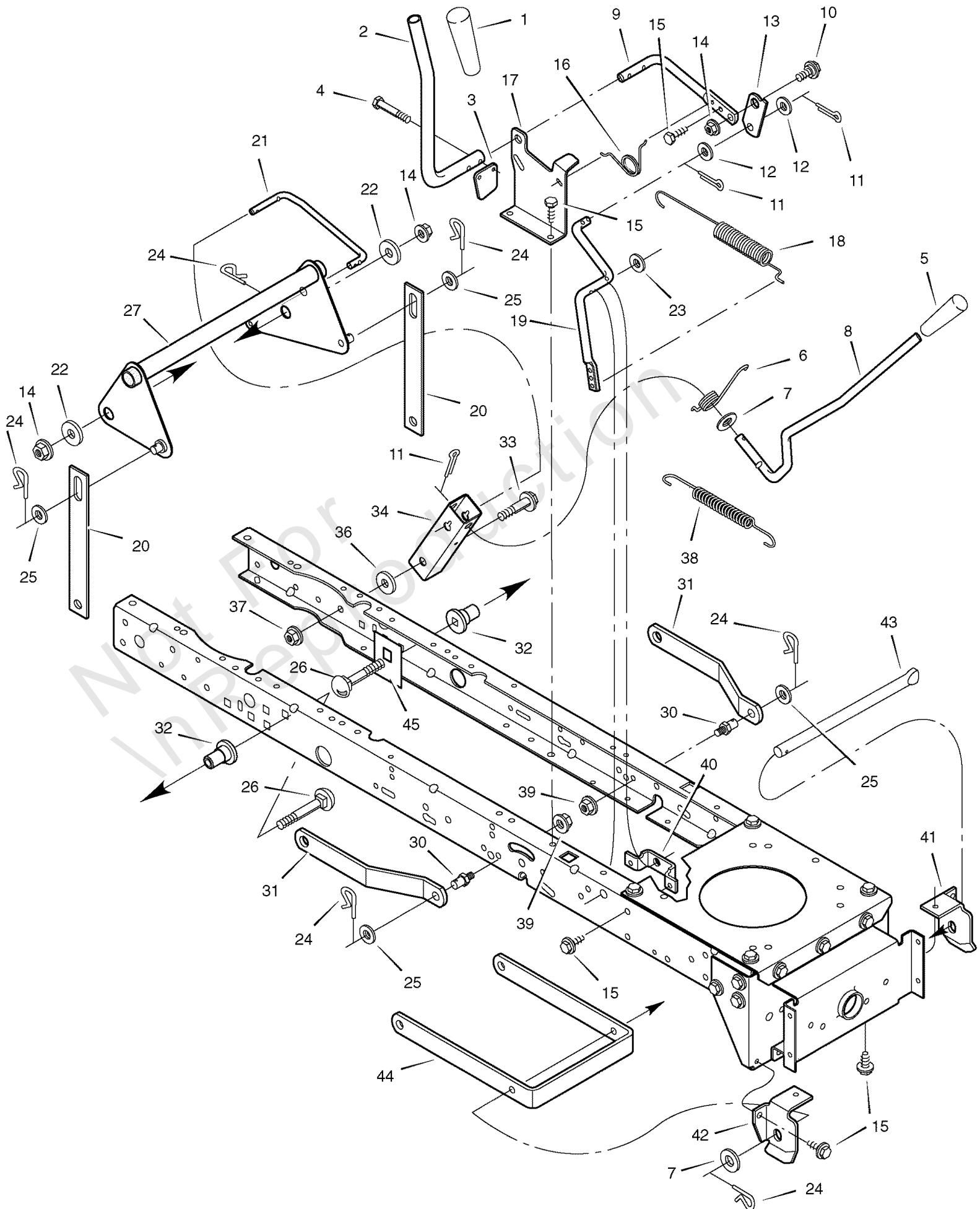

## Mower Housing Suspension

REF NO	PART NO	QTY	DESCRIPTION
1	1741757MA		GRIP
2	094157ZMA		HANDLE, PTO
3	094022ZMA		PAD, Switch
4	0025X3MA		Screw, Hex
5	1741756MA		GRIP
6	166X40MA		SPRING
7	17X103MA		WASHER
8	690533MA		HANDLE, Lift
9	094017ZMA		LEVER, PTO
10	009X39MA		BOLT, Shoulder
11	030X20MA		PIN, Cotter
12	017X57MA		WASHER
13	094004YZMA		LINK, PTO
14	7091619SM		NUT, Flange
15	26X249MA		SCREW
16	166X39MA		SPRING
17	7300821TMA		BRACKET, PTO
18	165X118MA		SPRING, PTO
19	690394E701MA		CRANK, PTO
20	7300749ZMA		LINK, Lift
21	7300877ZMA		LINK, Lift Handle
22	17X168ZMA		WASHER
23	017X57MA		WASHER
24	0031X4MA		PIN, Hair
25	017X91MA		WASHER
26	002X85MA		BOLT, Carriage
27	7500525ZMA		LEVER ASSEMBLY, Lift
30	094067MA		PIN
31	7300826ZMA		BRACKET, Rear Suspension
32	690151MA		SPACER, Lifter
33	009X53MA		BOLT, Shoulder
34	7300819ZMA		BRACKET, Pivot
36	17X191MA		WASHER
37	7091619SM		NUT, Flange
38	165X131MA		SPRING
39	015X68MA		NUT, Flange
40	7300796ZMA		BRACKET, PTO
41	7300860ZMA		HANGER, Left Deck
42	7300861ZMA		HANGER, Right Deck
43	094158ZMA		ROD, Hanger
44	7300767ZMA		BRACKET, Suspension
45	7300868ZMA		PLATE, Stiffening

# Steering

Note: Unless noted otherwise, use the standard torque specifications

Mfg. No: 7800319

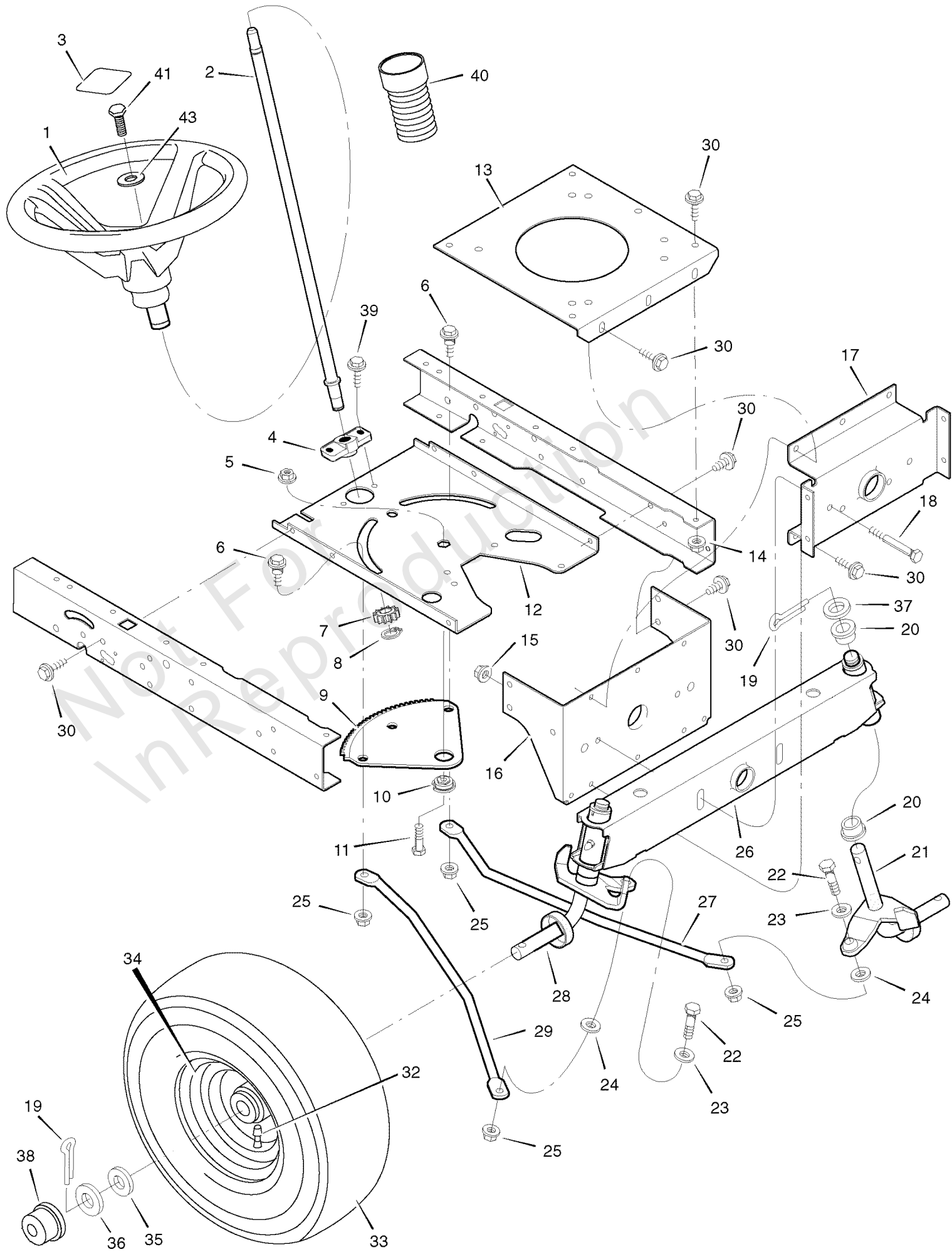



## Steering

REF NO	PART NO	QTY	DESCRIPTION
1	1001980MA		WHEEL, Steering
2	690625MA		POST, Steering
3	1001982MA		COVER, Steering Wheel
4	094124MA		Bearing -(Included with Ref. No. 2)
5	7090585MA		Nut, Flange **
6	009X57MA		BOLT, Shoulder
7	1001893MA		GEAR, Pinion **
8	011X25MA		Ring, Snap **
9	094121MA		GEAR, Sector
10	094123MA		BEARING
11	7027168SM		BOLT
12	7300867ZMA		PLATE, Steering
13	7300863ZMA		PLATE, Engine
14	015X88MA		NUT, Flange
15	15X118MA		NUT, Flange
16	7300751ZMA		BRACKET, Hanger
17	7300742ZMA		AXLE, Hanger
18	01X146MA		BOLT
19	030X49MA		PIN, Cotter
20	690150MA		BEARING
21	7400232ZMA		SPINDLE ASSEMBLY, Left
22	01X111MA		BOLT
23	710083MA		WASHER
24	017X53MA		WASHER
25	7091619SM		NUT, Flange
26	7500692ZMA		AXLE ASSEMBLY
27	7101805ZMA		DRAG LINK, Left
28	7400231ZMA		SPINDLE ASSEMBLY, Right
29	7101806ZMA		DRAG LINK, Right
30	26X249MA		SCREW
32	024373MA		STEM, Valve
33	091912MA		TIRE *
--	407924MA		TUBE
34	7101798MA		WHEEL & TIRE ASSEMBLY
35	17X195MA		WASHER
36	17X192MA		WASHER
37	17X113MA		WASHER
38	094618MA		HUB CAP
39	26X267MA		SCREW
40	092059MA		BELLOWS
41	0025X3MA		Screw, Hex
43	17X146MA		WASHER

### Footnotes:

Note\* When you order a tire, make sure to give the brand name of the tire so that the tread pattern on the tire will match.

Note\*\* This part included when ordering Ref. No. 2.

# Hardware Identification & Torque Specifications

Torque Specification Chart								
FOR STANDARD METRIC MACHINE HARDWARE (Tolerance ± 20%)								
Property Class	5.6		8.8		10.9		12.9	
	Class 5.6		Class 8.8		Class 10.9		Class 12.9	
Size Of Hardware	in/lbs	Nm.	in/lbs	Nm.	in/lbs	Nm.	in/lbs	Nm.
	ft/lbs		ft/lbs		ft/lbs		ft/lbs	
M3	5.88	.56	13.44	1.28	19.2	1.80	22.92	2.15
M4	13.44	1.28	30.72	2.90	43.44	4.10	52.56	4.95
M5	26.4	2.50	60.96	5.75	5.97	8.10	7.15	9.7
M6	44.64	4.3	7.3	9.9	10.3	14	12.1	16.5
M7	5.2	7.1	12.1	16.5	16.9	23	19.9	27
M8	7.7	10.5	17.7	24	25	34	29	40
M10	15	21	35	48	50	67	59	81
M12	26	36	61	83	86.2	117	103	140
M14	42	58	101	132	136	185	162	220
M16	64	88	147	200	210	285	250	340
M18	89	121	202	275	287	390	346	470
M20	126	171	290	390	405	550	486	660
M22	169	230	390	530	559	745	656	890
M24	217	295	497	375	708	960	840	1140
M27	320	435	733	995	1032	1400	1239	1680
M30	435	590	995	1350	1401	1900	1681	2280
M33	590	800	1349	1830	1902	2580	2278	3090
M36	759	1030	1740	2360	2441	3310	2935	3980
M39	988	1340	2249	3050	3163	4290	3798	5150

Torque Specification Chart						
FOR STANDARD MACHINE HARDWARE (Tolerance ± 20%)						
Hardware Grade	No Marks		SAE Grade 5		SAE Grade 8	
	SAE Grade 2		SAE Grade 5		SAE Grade 8	
Size Of Hardware	in/lbs	Nm.	in/lbs	Nm.	in/lbs	Nm.
	ft/lbs		ft/lbs		ft/lbs	
8-32	19	2.1	30	3.4	41	4.6
8-36	20	2.3	31	3.5	43	4.9
10-24	27	3.1	43	4.9	60	6.8
10-32	31	3.5	49	5.5	68	7.7
1/4-20	66	7.6	8	10.9	12	16.3
1/4-28	76	8.6	10	13.6	14	19.0
5/16-18	11	15.0	17	23.1	25	34.0
5/16-24	12	16.3	19	25.8	29	34.0
3/8-16	20	27.2	30	40.8	45	61.2
3/8-24	23	31.3	35	47.6	50	68.0
7/16-14	30	40.8	50	68.0	70	95.2
7/16-20	35	47.6	55	74.8	80	108.8
1/2-13	50	68.0	75	102.0	110	149.6
1/2-20	55	74.8	90	122.4	120	163.2
9/16-12	65	88.4	110	149.6	150	204.0
9/16-18	75	102.0	120	163.2	170	231.2
5/8-11	90	122.4	150	204.0	220	299.2
5/8-18	100	136	180	244.8	240	326.4
3/4-10	160	217.6	260	353.6	386	525.0
3/4-16	180	244.8	300	408.0	420	571.2
7/8-9	140	190.4	400	544.0	600	816.0
7/8-14	155	210.8	440	598.4	660	897.6
1-8	220	299.2	580	788.8	900	1,244.0
1-12	240	326.4	640	870.4	1,000	1,360.0

The guides and ruler furnished below are designed to help you select the appropriate hardware.



Nut, M8

Thread Diameter (mm)

Inside Diameter (in)      Threads per inch

Nut, 1/2-16

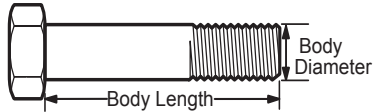

Screw, M8- 1.25 x 25

Thread Diameter (mm)      Distance between threads (mm)      Body Length (mm)

Body Diameter      Threads per inch      Body Length (in)

Screw, 1/2- 16 x 2



## Standard Hardware Sizing

When a washer or nut is identified as 1/2" (M8), this is the *Nominal size*, meaning the *inside diameter* is 1/2 inch (8mm metric thread diameter); if a second number is present it represents the *threads per inch* (distance between threads).

When bolt or capscrew is identified as 1/2 - 16 x 2" (M8 - 1.25 x 50), this means the *Nominal size*, or body diameter is 1/2 inch (8mm metric thread diameter), the second number, 16, represents the *threads per inch*, (*distance between threads*). The final number is the body length of the bolt or screw, 2 inches (50mm).

## NOTES

- These torque values are to be used for all hardware excluding: locknuts, self-tapping screws, thread forming screws, sheet metal screws and socket head setscrews.
- Recommended seating torque values for locknuts:
  - for prevailing torque locknuts - use 65% of grade 5 torques.
  - for flange whizlock nuts and screws - use 135% of grade 5 torques.
- Unless otherwise noted on assembly drawings, all torque values must meet this specification.

## Common Hardware Types

Hex Head Capscrew



Washer



Carriage Bolt



Hex Nut

## Wrench & Fastener Size Guide

1/4" Bolt or Nut Wrench—7/16"	5/16" Bolt or Nut Wrench—1/2"	3/8" Bolt or Nut Wrench—9/16"	7/16" Bolt or Nut Wrench (Bolt)—5/8" Wrench (Nut)—11/16"	1/2" Bolt or Nut Wrench—3/4"
M6 Bolt or Nut Wrench—10mm	M8 Bolt or Nut Wrench—13mm	M10 Bolt or Nut Wrench—17mm	M12 Bolt or Nut Wrench—19mm	M14 Bolt or Nut Wrench—22mm

**MURRAY®**