

INSTRUCTION BOOK

LAWN TRACTORS

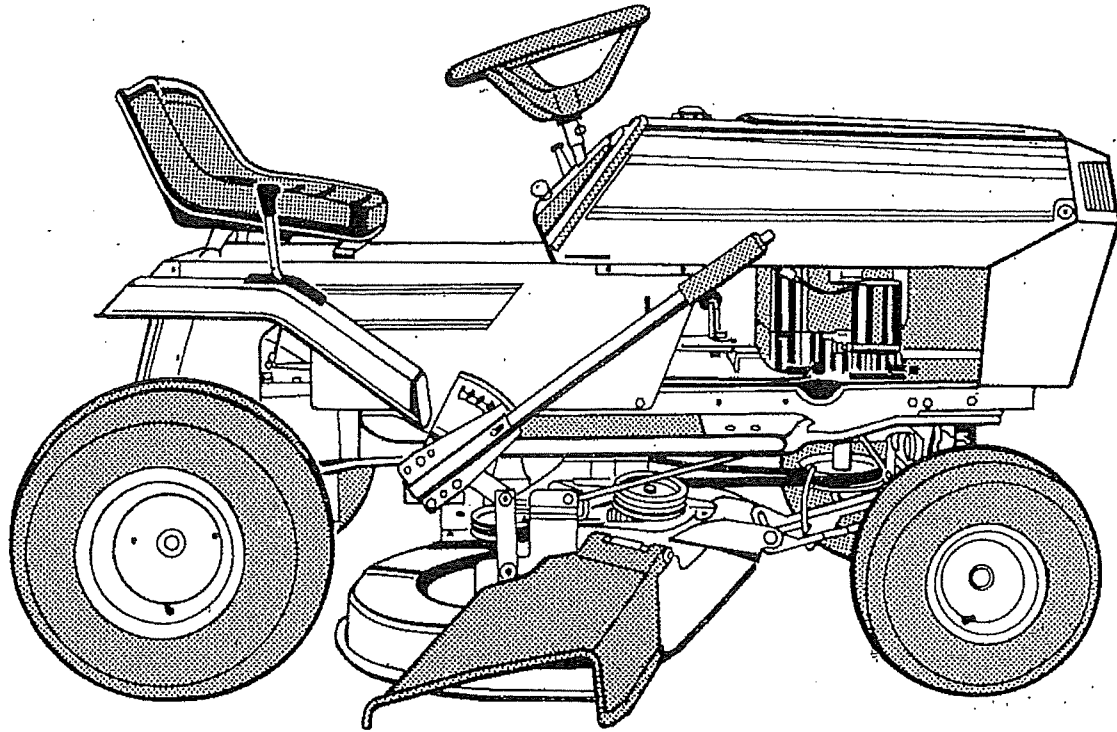

D-5730

D-5714

This Instruction Book contains instructions for several models.

PRODUCT INFORMATION

The owner must make sure that all the product information is included with the unit. This information includes the Instruction Book, the Repair Parts Book, and the Warranties. This information must be included to make sure state laws and other laws are followed.

Record the following information about your unit. This information is necessary when ordering parts or in case of loss or theft.

WHERE PURCHASED: _____
DATE PURCHASED: Month _____, Day _____, Year _____
MODEL NO.: _____ DATE of MANUFACTURE: _____
(Stamped on nameplate)

READ this book before riding this unit. **RETAIN** this book for future reference. Follow all directions in this book carefully, failure to do so will reduce the safety designed into this unit.

This Instruction Book contains important information on:

SAFETY

ASSEMBLY

OPERATION

MAINTENANCE

OWNER'S INFORMATION

This instruction book is for several different models. The instructions are written for a person with some mechanical ability. Like any service book, not all the steps are described. Steps on how to loosen or tighten fasteners are steps anyone can follow with some mechanical ability. Read and follow these instructions before you use the unit.

Know your product: If you understand the unit and how the unit operates, you will get the best performance. When you read this manual, compare the illustrations to the unit. Learn the location and the function of the controls. To help prevent an accident, follow the operating instructions and the safety rules. Keep this manual for future reference.

IMPORTANT: Many units are not assembled and are sold in cartons. It is the responsibility of the owner to make sure the assembly instructions in this manual are exactly followed. Other units are purchased in an assembled condition. On assembled units, it is the responsibility of the owner to make sure the unit is correctly assembled. The owner must carefully check the unit according to the instructions in this manual before it is first used.

RESPONSIBILITY OF THE OWNER

The responsibility of the owner is to follow the instructions below.

- Follow all the assembly instructions.
- Correctly adjust the unit.
- Carefully read and follow the rules for safe operation.
- Inspect the unit.
- Complete all maintenance on the unit.
- Know how to operate all standard and accessory equipment on the unit.
- Make sure that the operator knows how to correctly use the unit.
- Operate the unit only with guards, shields, and other safety items in place and working correctly.
- Service the unit only with authorized or approved replacement parts.

MURRAY TWO YEAR LIMITED WARRANTY

The Murray Ohio Manufacturing Company (Murray) warrants to the original purchaser that this unit shall be free from defects in material and workmanship under normal use and service for a period of Two (2) Years from the date of purchase; however, this warranty does not cover engines, accessories (such as snow blowers, snow blades, grass baggers and plows), transmissions, batteries and Normal Wear Parts (except as noted below) or transaxles as the companies that manufacture these items furnish their own warranties and provide service through their authorized field service facilities. For additional information, see the warranties covering these particular parts. If you are uncertain whether your unit contains or is equipped with one or more of these parts, consult your dealer prior to purchase. Subject to the terms and conditions noted in this Limited Warranty, we shall, at our option, repair or replace at no cost to the original purchaser any part covered by this Limited Warranty during the applicable warranty period.

In the event the battery proves defective within ninety (90) days from the date of purchase, we will replace it without charge. If the battery proves defective after (90) days but within one hundred twenty (120) days from the date of purchase, we will replace it for a charge of one half (1/2) of the retail price of the battery in effect at the time of return.

Normal Wear Parts are defined as belts, blades, blade adapters, pneumatic tires, headlights and seat covers. These parts are warranted to be free from defects in material and workmanship as delivered with the product. Any claim for repair or replacement of Normal Wear Parts must be made within thirty (30) days of the date of purchase. No claims involving damage caused from material use, abuse or misuse will be honored.

This Murray Two (2) Year Limited Warranty is your exclusive remedy; however, this warranty is void or does not apply to any unit that has been tampered with, altered, misused, abused or used for rental or other commercial and/or professional (non-homeowner) uses. Your warranty does not cover minor mechanical adjustments which are not due to any defect in material or workmanship. For assistance in making such adjustments, consult your Instruction Book.

To make a claim under this Murray Two (2) Year Limited Warranty, return the unit (or if authorized in advance, the defective part) along with your proof of purchase to an Authorized Service Center near you. To locate the nearest Authorized Service Center, call the Central Parts Distributor for your area shown in the list provided with your unit or check the Yellow Page listings in your local telephone directory. If you return the entire unit, we will repair the unit. If we authorize the return of the defective part only, we will either replace or repair the part. In the case of a defect in a transmission or differential (as distinguished from a transaxle), the entire transmission or differential must be returned since they do not include user serviceable parts.

This Murray Two (2) Year Limited Warranty gives you specific legal rights, and you may also have other rights which vary from state to state. If you need additional information on this written warranty or assistance in obtaining service, write:

MURRAY

Outdoor Power Equipment
Customer Service Department
P.O. Box 268; Brentwood, Tennessee 37027

SAFETY RULES

Safe Operation Practices for Riding Vehicles
As Recommended by American National Standards Institute

This cutting machine is capable of amputating hands and feet and throwing objects. Failure to observe the following safety instructions could result in serious injury or death to the operator or bystanders.

GENERAL OPERATION:

1. Read, understand, and follow all instructions in the Instruction Book, on the machine, on the engine, and with any attachments before starting.
2. Only allow responsible adults familiar with the instructions to operate the machine.
3. Clear the area of objects such as rocks, toys, wire, etc. which could be picked up and thrown by the blade.
4. Be sure the area is clear of other people before mowing. Stop the machine if anyone enters the area.
5. Never carry passengers.
6. Disengage all attachment clutches and shift into Neutral before attempting to start the engine.
7. Disengage power to the mower or any attachments before backing up. Do not mow in reverse unless absolutely necessary. Always look down and behind before and while backing.
8. Be aware of the direction the mower discharge. Do not point discharge from the mower at anyone or at places where people may be. Do not operate the mower without either the entire grass bagger or the mower guard in place.
9. Slow down before turning.
10. Never leave a machine unattended with the engine running. Always disengage the blade(s), set the parking brake, stop the engine and remove the key before dismounting.
11. Disengage power to attachment(s) when transporting or not in use. Disengage the blade(s) when not mowing.
12. Stop the engine before removing the grass bagger or unclogging the chute.
13. Mow only in daylight or good artificial light.
14. Do not operate the machine while under the influence of alcohol or drugs or when very tired.
15. Watch for traffic when operating near or crossing roadways.
16. Use extra caution when loading or unloading the machine when using a trailer or truck for transporting.
17. Always wear safety glasses or an eye shield when you operate the unit to protect your eyes from foreign objects that can be thrown from the unit. Always wear eye protection when you make an adjustment or repair to the machine.
18. Use care when pulling loads or using heavy equipment.
 - a. Use only approved drawbar hitch points.
 - b. Limit loads to those you can safely control.
 - c. Do not turn sharply. Use care when backing.
 - d. Use counterweights or wheel weights when suggested in the Instruction Book.

CHILDREN:

Tragic accidents can occur if the operator is not alert to the presence of children. Children are often attracted to the machine and the mowing activity. Never assume that children will remain where you last saw them.

1. Keep children out of the mowing area and in the watchful care of an adult other than the operator.
2. Be alert and turn the engine off if children enter the area.
3. Before and when backing, look behind and down for small children.
4. Never carry children or any passengers. They may fall off and be seriously injured or interfere with the safe operation of the machine.
5. Never allow children to operate the machine. Instruct children in the dangers of the machine.
6. Use extra care when approaching blind corners, shrubs, trees or other objects that may obscure vision.

SAFETY RULES - continued

SLOPE OPERATION:

Slopes and rough terrain are major factors related to loss of control and tip over accidents which can result in severe injury or death. All slopes require extra caution. If you cannot back up the slope or if you feel uneasy on the slope, do not mow it. See the "Slope Guide" in the back of this book to check for safe operation.

DO

- Mow up and down slopes, not across.
- Remove obstacles such as rocks, limbs, etc.
- Watch for holes, ruts or bumps. Uneven terrain could overturn the machine. Tall grass can hide obstacles.
- Use slow speed. Choose a low enough gear so that you will not have to stop or shift while on the slope.
- Follow the manufacturer's recommendations for wheel weights or counterweights to improve stability.
- Use extra care with grass baggers or other attachments, they can change the stability of the machine.
- Keep all movement on the slopes slow and gradual. Do not make sudden changes in speed or direction.
- Avoid starting or stopping on a slope. If tires lose traction, disengage the blades and proceed slowly straight down the slope.

DO NOT

- Do not turn on slopes unless absolutely necessary, then only turn slowly and gradually downhill, if possible.
- Do not mow near drop-offs, ditches or embankments. A wheel over the edge or an edge caving in could cause a sudden overturn and an injury or death.
- Do not mow on wet grass. Reduced traction could cause sliding.
- Do not try to stabilize the machine by putting your foot on the ground.
- Do not use a grass bagger or other rear mounted accessories on steep slopes.

SERVICE:

1. Use extra care when handling gasoline and other fuels. Fuels are flammable and the vapors are explosive.
 - a. Use only an approved container.
 - b. Never remove the gas cap or add fuel with the engine running. Allow the engine to cool for several minutes before refueling. Do not smoke.
 - c. Never refuel the machine indoors.
 - d. Never store the machine with fuel in the tank or fuel container inside where there is an open flame, such as a water heater.
2. Never start or run the engine inside an enclosed area.
3. Keep all nuts and bolts, especially the blade attachment nuts tight. Frequently check the blade(s) for wear or damage such as cracks and nicks. A blade that is bent or damaged must be immediately replaced with a factory replacement blade. For safety, replace the blade every two years. Keep the equipment in good condition.
4. Never tamper with the safety devices. Check their proper operation regularly.
5. To reduce fire hazards keep the machine free of grass, leaves or other debris build-up. Clean up oil or fuel spillage. Allow the machine to cool before storing.
6. Stop and inspect the equipment if you strike an object. Repair, if necessary, before re-starting.
7. Never make adjustments or repairs with the engine running. The carburetor can be adjusted with the engine running. Do not change the engine governor settings or overspeed the engine.
8. Grass bagger components are subject to wear, damage and deterioration, which could expose moving parts or allow objects to be thrown. Frequently check components and replace with manufacturer's recommended parts when necessary.
9. Mower blade(s) are sharp and can cut. Wrap the blade(s) or wear gloves and use extra caution when servicing them or the blade housing area.
10. Check the brake operation frequently. Adjust and service as required.
11. Wait for all movement to stop before servicing any part of the unit.



Look for this symbol to point out important safety precautions. It means:
"Attention! Become Alert! Your Safety Is Involved."

SAFE MOWING GUIDE

Each person that operates power equipment must learn to use correct and safe mowing procedures. To help you learn, carefully read the following pages. Most of the time the operator was not correctly instructed on how or did not read the instructions on the unit or in the Instruction Book before using the unit. Also, some operators do not have enough experience. This can result in unsafe use endangering the operator, bystanders, and the equipment. Another result can be a poor appearance of the area mowed.

Read this book. Read the instructions on the unit. Operate the mower according to the Safe Mowing Guide. Follow all safety rules, cautions or warnings in this book and on the unit. Make sure anyone that uses the unit reads the instructions and is told how to safely operate the mower.

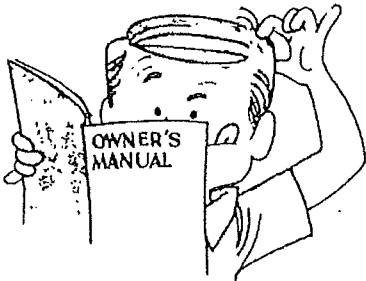

The mower will provide you good service and durability, if operated in normal conditions: If the mower is not correctly serviced or is used where the terrain is rough or unsuitable, product performance and safety will be reduced.

Correct clothing is an important part of safe mowing. Safety glasses will protect the eyes from objects discharged by the mower. Safety shoes with steel plates may protect a foot from injury by the blade. For protection from objects discharged from the mower, wear sturdy clothing that will cover the arms and legs.

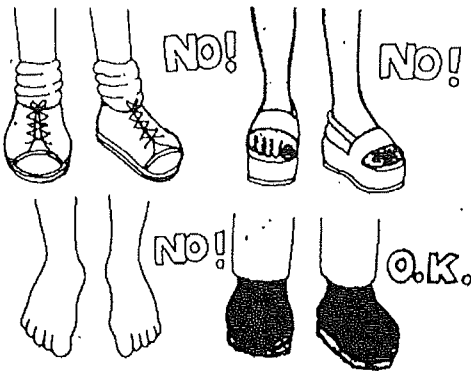

Prior to cutting grass, practice using the mower in a large open and level area. Learn the location of the controls on the mower. Know the purpose of the controls and how they work. In an emergency, how fast you can stop the blade is important. Learn how to control the mower at all times.



Many engines are started by hand. When you use a pull start or rope start, place your feet apart and away from the blade(s). Hold the rope handle tight. Never wrap the rope around your arm or fingers for a "better grip". To start the engine, follow the instructions on the mower, in this book and in the engine booklet.

For electric start engines, sit in the seat to start the engine. The battery can be dangerous. Follow the instructions on the battery, the acid container, and in this book when working with the battery. Even small batteries have enough voltage to cause an injury. Always be careful.

The mower is designed to be operated by one person. Never let another person ride with you on the unit or on any accessories. A passenger on the unit will make the unit harder to control, block the visibility or distract the operator and is dangerous to the operator, passenger and the equipment. Without a passenger seat, a passenger can fall from the mower or contact dangerous parts. A mower is not a toy for showing off or for giving rides.

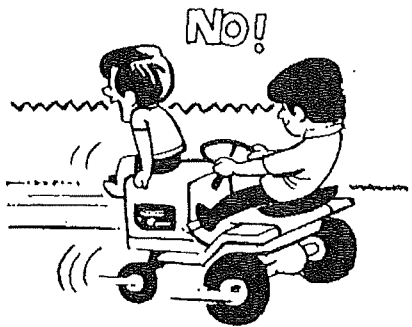

Never cut a wet lawn. Cutting wet grass can cause an accident, it can affect mower performance, and it can cause problems with future lawn growth and appearance. Wet grass is slippery and might cause the mower to slip. Someone could get hurt by touching the blade(s). Wet grass tends to clog the mower, causing poor discharge. The wet clippings bunch up on the lawn retarding the growth of the grass under them. Also, getting the mower wet will cause parts to rust and decrease the life of the unit.

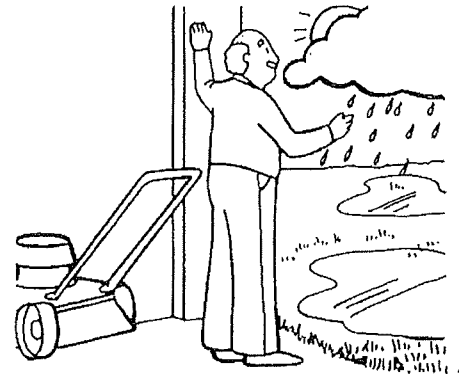

When you look over the lawn, remember obstacles that cannot be removed, like pipes, stumps or rocks. Keep away from these obstacles that can cause damage to the mower or injury to the operator or a person near the mower. Clear the area of rocks, toys, wire, or other loose objects. These items can damage the mower or can be discharged by the mower blade. The blade of a power mower rotates very fast. It can discharge rocks and other objects over a long distance which can be dangerous. The force of the objects can break windows, cause injuries, or even put out an eye. Most of the time the injury is to a person, like a child. Keep every person completely away from the area to be mowed. Make sure the grass is not discharged toward anyone. Planning your mowing pattern has a double benefit. It can reduce chances of an injury and make the clean up after mowing easier.

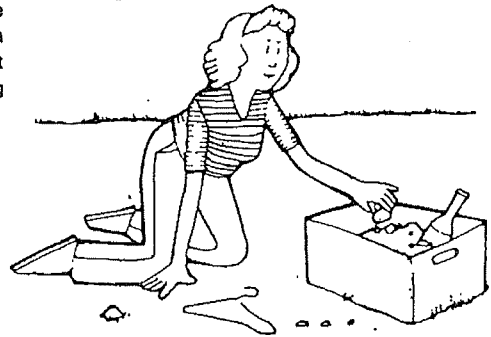

Check the terrain of the area to be mowed. Mow in a pattern that will keep you away from dangerous areas. Check the distance you need to stop and the distance available to turn. Slopes and rough terrain must be mowed carefully and some areas must not be mowed at all. With riding mowers, mow up and down the hill. When you must mow rough terrain or on slopes, never change directions or change gears and stop in such areas only in an emergency. Before you ride up or down a slope, try to back straight up the slope. Do not ride up or down a slope that is too steep to back straight up. See the "Guide" in the back of this Instruction Book to check any slopes.

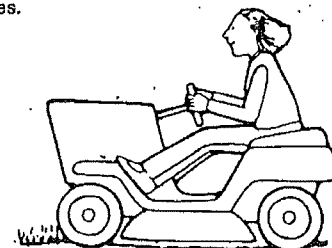

Before you start cutting, make sure the mower was completely assembled according to the Instruction Book. If you got the mower from the store completely assembled, you must still check the mower according to the assembly instructions. Make sure the mower is correctly assembled and that all fasteners are tight. Make sure the engine has the correct amount of oil. Check these items often during the life of the mower.

Your mower has a gasoline engine. Gasoline is a dangerous fuel. Keep gasoline only in an approved safety gasoline container. Do not keep large amounts of gasoline. When you add gasoline to the fuel tank, do not smoke. Store the gasoline container and the mower in an area that has good ventilation. Also, keep the gasoline away from any flames like the pilot light of a furnace or any other source of ignition. If the mower is to be stored for more than a few weeks, remove the gasoline from the fuel tank. When inside an enclosure, do not add gasoline to the fuel tank. Before you add gasoline, move the mower outside and add gasoline carefully. Before you start the engine, remove any gasoline from the outside of the fuel tank or from the mower. Warm gasoline will expand. Leave some space in the fuel tank for the gasoline to expand. Also, the fuel cap has a vent hole for fuel vapors. Always use the correct fuel cap. Failure to follow safety rules about gasoline will cause fires and explosions, personal injury and damage to the equipment and other property.

If you add gasoline to an engine that is running or hot, the result can be an explosion. Before you add gasoline, stop the engine and let the engine cool for several seconds. Remove dry grass and other debris from the mower. Keep the mower clean to improve the performance, help the engine run cooler, extend the life of moving parts, and decrease the danger of a fire. Fires and explosions are not the only dangers when working around a mower. The engine and the muffler will get hot in several minutes when the engine is running. Do not touch these parts of the mower. Stop the engine. Let the engine cool before servicing the mower. Remember, exhaust fumes are dangerous. Never operate the engine inside a building.

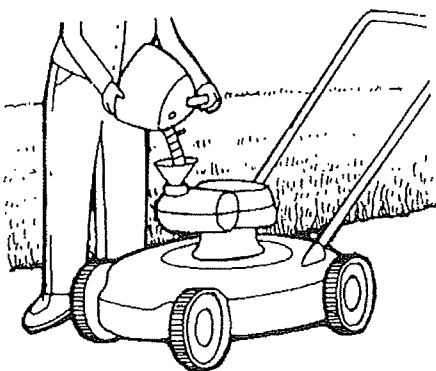

When you get a new mower, it can be a new experience for the family. Tell each person how a mower can be dangerous. Remember, a mower is not a toy. A mower is not to be used by children or anyone not old enough, strong enough or that does not have experience.

F-90785

If the mower is not correctly assembled, not operated correctly, or not regularly serviced, the mower can be dangerous. The most important rule to follow is always use good judgement and common sense. Mow safely and carefully.

Your mower will easily cut thick grass. Fingers, feet and other parts can also be cut by the blade. Injuries occur when the operator does not think and reaches into the chute opening. Always operate the lawn mower as if the blade is rotating. Do not service or make an adjustment, except to the carburetor, while the engine is running.

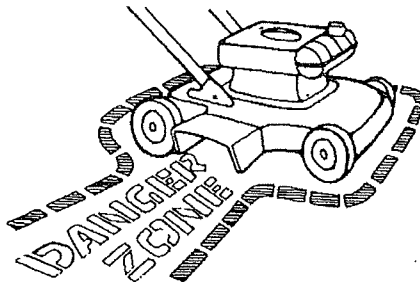

Use only accessories that are factory approved for your mower. The wrong accessory can decrease the safety of the mower and can even damage the unit. Read and follow the instructions included with the accessory and the mower.

Use only original equipment or replacement parts that are factory approved for service. If you need service, select an Authorized Service Center for your mower. If you do the work on the unit, follow the instructions in the Instruction Book.

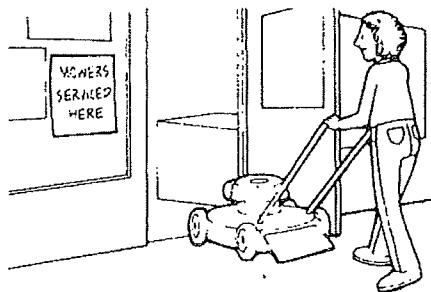

When you mow, remember that children are attracted to the mower. Always use caution when mowing around an obstacle such as trees or shrubs or when moving backward. Only mow when you go forward if at all possible. Your visibility is decreased when you mow backward. Also, the blades are made to cut while the unit is moving forward. If you mow backward, the cutting performance decreases.

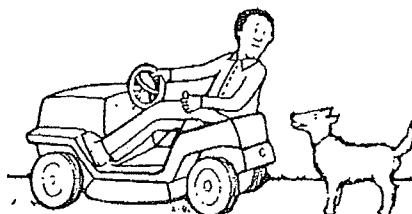

Before you leave the mower, stop the engine. Remove the key. Disengage and lower any attachment. Set the parking brake. Never mount or dismount from the seat while the engine is running. An accident can occur if you touch the brake, shift lever, throttle, clutch or blade control while the engine is running. Mount and dismount from the seat on the side of the unit that is marked ENTER-EXIT.

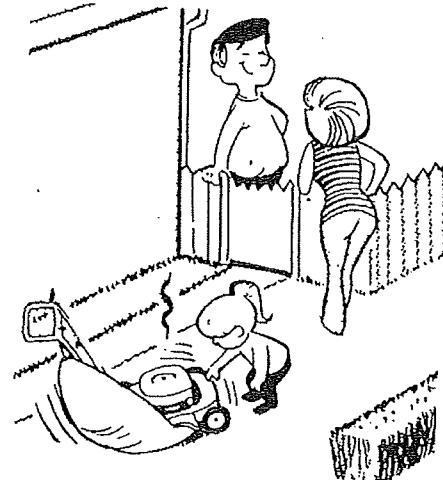

Make sure you are in good condition when you mow. When you mow for several hours your reflexes will decrease and your mind will not be as alert. Take a short break or an accident can occur. If the temperature is hot, use caution to prevent dehydration. If you are tired, angry, or not completely alert, do not operate the mower. If you use alcohol, medication, or drugs, do not use the mower or any type of power equipment.

If the weather conditions are bad, do not start to mow. If weather conditions become bad, stop cutting and finish later. It is dangerous to cut grass in the rain. Always find protection in an electrical storm. If the weather conditions are extra dry, protect your eyes with safety glasses from the dust and from the objects discharged by the mower. Also, a dust or a pollen mask can help.



Your mower is equipped with a number of safety devices which are important to the safety of the operator and bystanders and must never be changed or removed from the mower. If a safety device is lost, damaged or no longer functions, repair or replace the device before you operate the mower.

Engine speed is a key to safe mowing and to a good looking lawn. The maximum speed of the engine was set at the factory. Do not change the setting of the engine governor.

Select the maximum engine and ground speed that is right for the terrain and the height of the grass. The blade cuts best when the engine is operating at maximum speed. Also, the grass bagger will function better when the engine is operating at maximum speed. On slopes, decrease the ground speed and use care making sure the mower feels safe to operate.

It is best to mow during the day. If you must mow at night, make sure there is enough light for safe operation.

Your mower will require regular maintenance and service. The maintenance schedule depends on the hours of use. Also, mowing conditions can change the schedule. Check the Instruction Book for more information. Correct maintenance will help the mower function safely. Do not service the mower (except for the carburetor adjustment) while the engine is running. Before you service the unit, even with the engine stopped, always remove the wire from the spark plug to prevent the engine from starting.

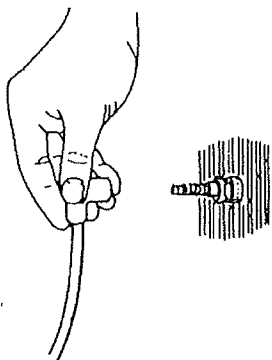

If you hit a large object during operation, stop the engine. Remove the wire from the spark plug wire. Carefully inspect the mower for damage. Before you start the engine again, make the necessary repairs. If you feel new or excessive vibration, immediately stop the engine and check for the problem. Vibration may be a warning of a problem. Keep all nuts, bolts and screws tight.

The blade is the most dangerous part of the mower. Frequently check the blade and the blade mounting fasteners. Keep the fasteners tight. If the blade hits a solid object, stop the engine. Remove the wire from the spark plug. Check for a blade that is bent, cracked or for other damages. Before you start the engine, replace a damaged blade. For safety, replace the blade every two years.

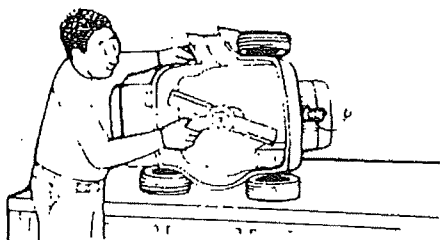

A sharp blade decreases the work load on the engine and more evenly cuts grass. Frequently sharpen the blade for a better looking cut. Use the left side of the mower housing to trim near an object.

A grass bagger is a good accessory for your mower. For best performance and safety, make sure the grass bagger is approved for use with your mower. Follow the assembly and operation instructions included with the grass bagger.

Some grass baggers require a special blade for best performance. Before you attach, check, or empty the grass bagger, always stop the engine. Before each use of the grass bagger, check for cracks, wear or deterioration. Before you use the grass bagger, replace a damaged part with a replacement part approved by the factory.

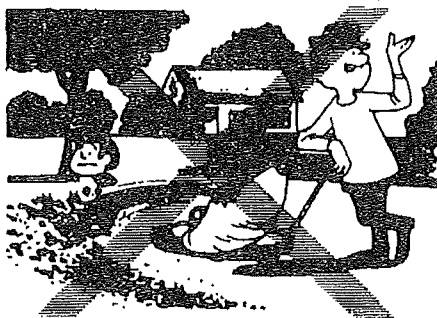

For you to have a good green lawn, follow the mowing procedures below. Do not cut the grass too short. If you cut the grass too short you can cause the grass to become yellow or make the lawn look brown. Use a lower height of cut in cool months when the grass is thicker. Raise the height of cut in hot dry periods. If you cut the grass with a blade that is not sharp or at a slow engine speed you can damage the grass. Move the throttle control to the FAST position when mowing and using the grass bagger. Also, use a slower ground speed when using the grass bagger.

Changing the direction or pattern of cut slightly each time you mow will make the grass grow stronger and thicker. Do not add oil or gasoline to the mower while on the lawn. Spilled oil or gasoline can kill the grass. In tall or thick grass, do not try to cut it all at once. Raise the height of cut on the first cutting and lower it for the next cutting. Another way is to cut only part of the width of the mower and adjust your ground speed (not the engine) to move more slowly so that the mower can discharge the grass as it moves forward.

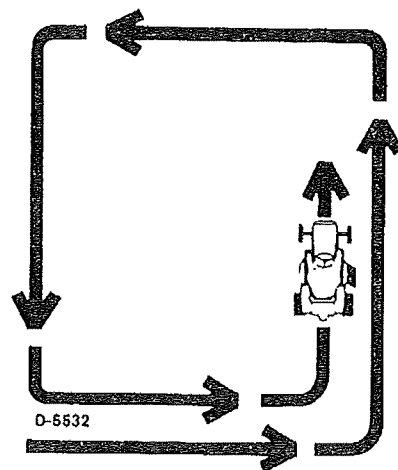

Understand the controls and how they work. Learn the ground speed(s) of your mower. Check the stopping distance required at different throttle and gear positions. Check the turning radius of the mower. The controls on your riding mower are different from an automobile. The throttle is operated by hand and holds the engine speed constant until it is changed. The location of the shift lever and the shift pattern is different from that of an automobile. Also, the brake and clutch systems are different. Remember the procedures to follow in an emergency. Remember, turning the engine ignition switch off will stop the blade and the drive mechanism. If the traction of the wheels is lost or does not feel safe, disengage all systems and stop the engine. Dismount from the mower. Push the unit to a safe place before you begin mowing again.

Your unit has an electrical system that includes an operator presence switch in the seat. The operator presence switch detects if the operator is sitting on the seat. The engine will stop if the operator leaves the seat when the blade engagement control is engaged. This operator presence switch is a safety device only. It must not regularly be used to stop the engine or the blade. There are other control systems on the mower for this purpose. Always keep the operator presence switch and other safety devices and controls in place and operating for your protection.

Remember, your mower is a tool that can be dangerous if it is not correctly used. Follow the instructions in this Instruction Book. Safe and careful use of the mower will give you many safe hours of problem free use.

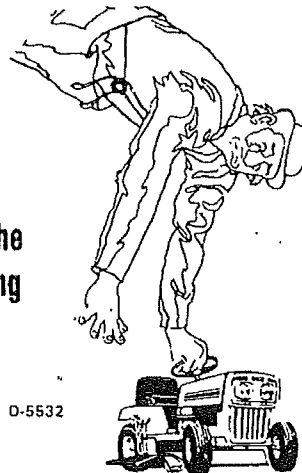

**MOW
right...
leave the
clowning
to us.**

D-5532

STEPS TO FOLLOW

BEFORE MOWING

- Be sure to dress correctly. Wear hard shoes, not sandals or tennis shoes.
- Examine the blade. A blade that is bent, cracked, or damaged must be replaced with a factory replacement blade.
- Fill the fuel tank outside. Clean off spilled fuel.
- Owner's Manual instructions are for your safety and the safety of others.
- Read and follow the Owner's Manual, instructions with the engine and the attachments.
- Exhaust fumes are dangerous. Start the engine outside.
- Make sure all safety devices are in place and working correctly.
- Operation of the mower is only for a person that has experience.
- Wet grass can be dangerous. Let the grass dry.
- Instruct children and others to keep away from the work area.
- Never cut the grass without good light.
- Gather up loose objects. Remove them from the mowing area.



WHILE MOWING

- Watch for fixed objects and avoid them. They can damage the mower or cause injury.
- Hot engine and muffler will cause a burn. Do not touch.
- Inclines and slopes must be carefully mowed. See the "Guide" in the back of this book to check a slope.
- Lack of daylight or good artificial light is cause to stop mowing.
- Examine the mower, the blade, and other parts for damage after hitting a foreign object or if the unit vibrates excessively.
- Make no adjustments or repairs without stopping the engine (except for carburetor). Disconnect the spark plug wire.
- On or near roads, watch out for traffic. Direct discharge away from roads.
- When mowing, avoid areas where traction is unsure. Look back before changing direction of travel.
- In heavy grass, raise the cutting height. Cut slower. Stop the engine to remove clogged grass from the mower.
- Never remove any safety related parts.
- Gasoline must not be poured into a engine that is hot or running.

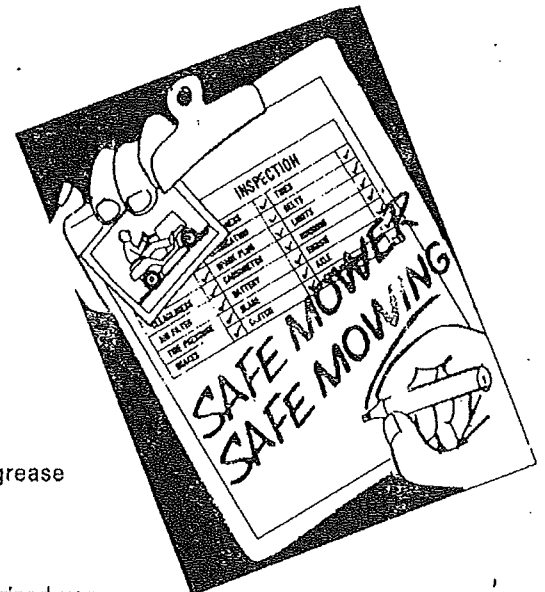

AFTER MOWING

- Always let the mower cool before storing in an enclosed area.
- Foreign material on the mower is dangerous. Clean off grass, leaves, grease and oil before storing.
- Tighten all loose nuts, bolts and screws before you use the unit.
- Empty and clean any grass catcher or other accessory.
- Remove the key or disconnect the spark plug wire to prevent unauthorized use.
- Make sure the mower is not kept near a source of ignition. Gas fumes can cause an explosion.
- Only original parts or factory approved substitutes can be used to service the mower.
- When storing the mower for an extended period, remove the fuel from the fuel tank.
- Instruct children to leave the mower alone. It is not a toy.
- Never keep gasoline near a source of ignition. Always use an approved container. Keep gasoline away from children.
- Lubricate according to the Instruction Book. See "Lubrication".

IMPORTANT--Read the Instruction Book. Keep this book for future use and reference.

ASSEMBLY

This instruction book is for several models. Some parts or accessories are not included on all models. Read and follow the assembly and adjustment instructions for your mower. All fasteners are in the parts bag. Do not discard any parts or material until the unit is assembled.



WARNING: Remove the wire from the spark plug before you do any assembly or maintenance to the mower.

NOTE: In this instruction book, left and right describe the location of a part with the operator on the seat.

NOTE: Torque is measured in foot-pounds (metric N-meters). This measurement describes the tightness of a nut or bolt. The torque is measured with a torque wrench.

TOOLS REQUIRED



1 Pliers

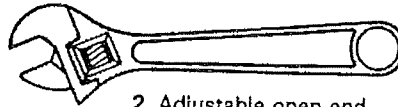

2 Adjustable open end wrenches

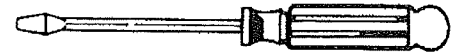

1 Blade type screwdriver

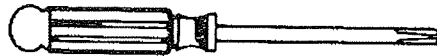

1 Phillips screwdriver

PARTS BAG - contents

The fasteners and other loose parts are shown below. The fasteners are shown at full size with the quantities in brackets ().



15x66
(2) Locknut
1/4"-20

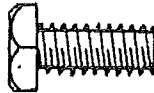

1x38
(2) Hex Bolt
1/4"-20x5/8"

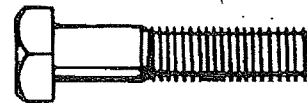

1x66
(1) Hex Bolt
5/16"-24x1 1/2"

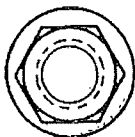

15x90
(1) Flange Hex Nut
5/16"-24

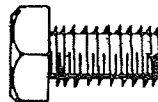

1x45
(2) Hex Bolt
5/16"-18x5/8"



26x184
(1) Screw



18x16
(2) Lockwasher



91941
(1) Battery Clip
(Not shown full size)

ASSEMBLY

HOW TO PREPARE AND CHARGE THE BATTERY

IMPORTANT: Before you install the battery, add the battery acid, (Electrolyte) to the battery. Battery acid will damage paint and parts.



WARNING: Read the instructions included with the battery acid container. Protect your hands and eyes from the battery acid. Use clothing that will protect you.

1. Remove the vent caps from the battery. Pour battery acid into each battery cell until the battery acid touches the bottom of the vent as shown. Do not add the battery acid above the bottom of the vent. If you add too much battery acid, the excessive battery acid will flow from the battery when you charge the battery.
2. Wait 20 to 30 minutes before you put the vent caps on the battery. The level of the battery acid can drop below the vent described in step 1. Add more battery acid until the correct battery acid level is reached. Install the vent caps. Wash the top of the battery with water to remove any battery acid.
3. Discard the battery acid container and any battery acid that was not used as follows. Fill the container half full with water. Add baking soda and mix together using a piece of wood. Add more baking soda until the solution does not foam. Discard the solution and wash the container with water. Destroy the container.



WARNING: When you charge the battery, do not smoke. Keep the battery away from any sparks. The fumes from the battery acid can cause an explosion.

4. Use a 12 volt battery charger to charge the battery. Charge at a rate of 6 amperes for one hour. After the battery is charged, check the level of the battery acid. If the level of the battery acid falls, add water. Do not add battery acid to a charged battery or the result can be an explosion.

CUT AWAY VIEW

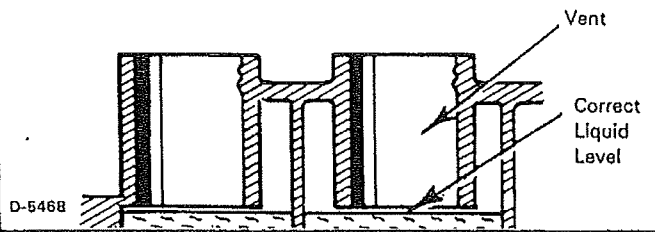

DANGER BATTERY ACID WILL CAUSE SEVERE BURNS

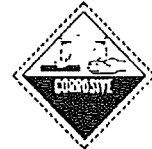

Contains sulphuric acid.

Do not let the battery acid come in contact with the skin, the eyes, or the clothing.

To prevent accidents, neutralize the battery acid that was not used. To neutralize, fill the container half full with water. Add baking soda and mix using a piece of wood until the solution does not foam. Discard the solution and wash the container with water. Destroy the container.

ANTIDOTE:

External - Wash the area with water, then wash with a solution of water and sodium bicarbonate.

Internal - Drink large amounts of water, milk, or milk of magnesia. Drink water mixed with the whites of eggs. Call a Doctor immediately.

Eyes - Flush with water for 15 minutes and then get immediate medical help.

POISON

KEEP AWAY FROM CHILDREN -

D-6213

HOW TO ASSEMBLE THE STEERING WHEEL

Use the fasteners shown below to install the steering wheel. The fasteners are shown at full size.

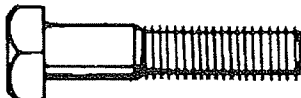

(A)
1x66

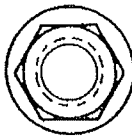

(B)
15x90

1. Make sure the front wheels point forward. Attach the steering wheel to the steering post with the fasteners as shown.

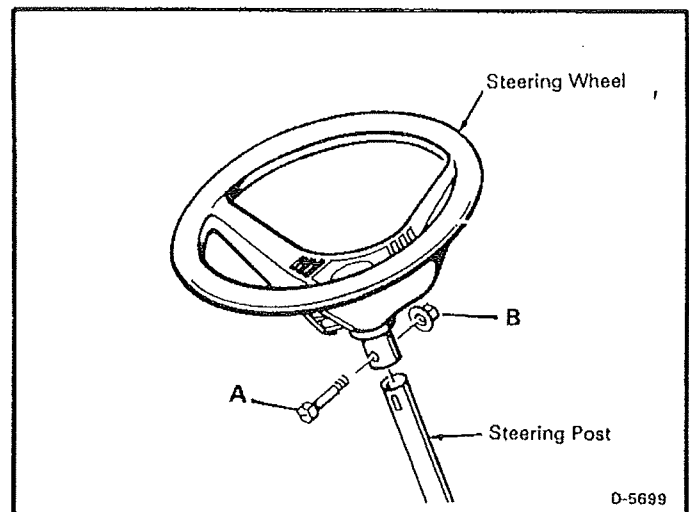

ASSEMBLY

HOW TO INSTALL THE BATTERY

Use the fasteners shown below to install the battery. The fasteners are shown at full size.

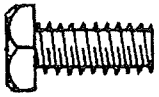

(A)
1x38



(B)
15x68



(C)
26x184

1. Install the battery tray. Make sure the drain on the bottom of the battery tray goes through the hole in the frame as shown.
2. Turn the battery so that the positive (+) terminal is on the right side of the unit. Set the battery in the battery tray. **IMPORTANT: Make sure the battery fits under the tabs at the back of the unit.**
3. Slide the battery clip on the frame. Attach the battery clip with the fastener as shown in the illustration.



WARNING: To prevent sparks, fasten the red cable to the positive (+) terminal before you connect the black cable.

4. Fasten the red cable to the positive (+) terminal with the fasteners as shown.
5. Fasten the black cable to the negative (-) terminal with the fasteners as shown.

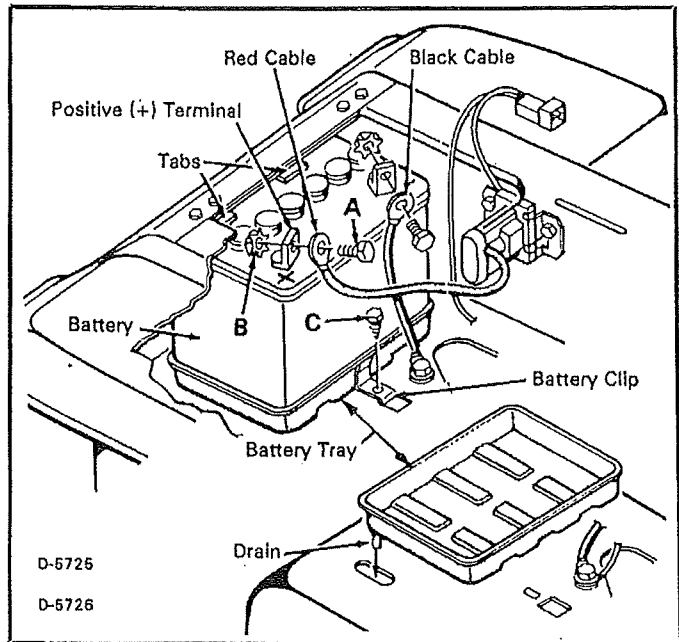

HOW TO INSTALL THE SEAT

Use the fasteners shown below to install the seat. The fasteners are shown at full size.

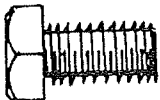

(A)
1x45

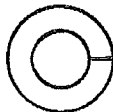

(B)
18x16

1. Align the holes in the seat hinge to the holes in the seat. Fasten the seat to the seat hinge with the fasteners as shown.
2. Check the operating position of the seat. If the seat needs to be adjusted, loosen the nuts on the seat hinge. Slide the seat forward or backward along the adjusting holes as shown. To keep the seat straight, align the rear edge of the seat hinge with the marks on the top of the console. Tighten the hex nuts.
3. Connect the wire from the seat switch sensor to the wire harness. Make sure the tab part of the connector, from the seat switch sensor, locks into the latch of the wire harness connector.



WARNING: For correct and safe operation of the unit, connect the wire from the seat switch sensor to the wire harness.

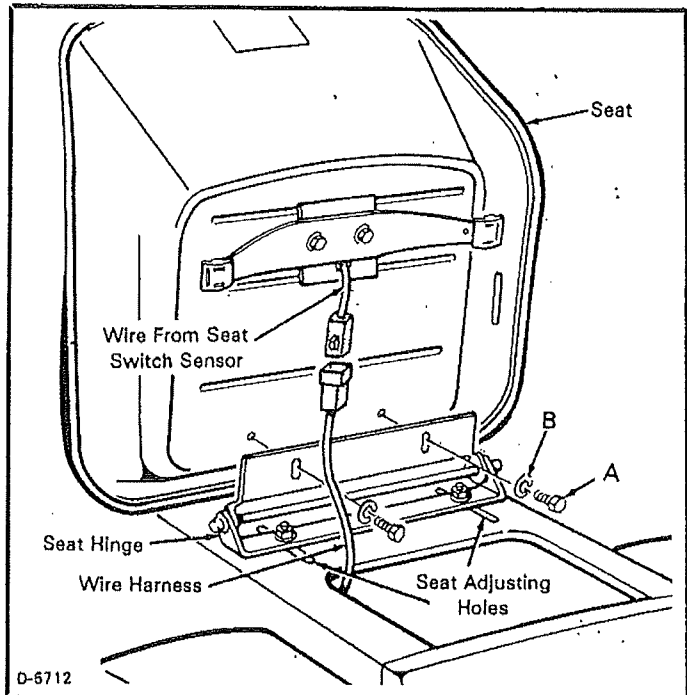

ASSEMBLY

HOW TO PREPARE THE ENGINE

THE ENGINE DOES NOT CONTAIN OIL OR GASOLINE.

See the engine manufacturer's instructions for the type of gasoline and oil to use. Before you use the unit, read the information on safety, operation, maintenance, and storage.



WARNING: Follow the engine manufacturer's instructions for the type of gasoline and oil to use. Always use a safety gasoline container. Do not smoke when adding gasoline to the engine. When inside an enclosure, do not fill with gasoline. Before you add gasoline, stop the engine. Let the engine cool for several minutes.

IMPORTANT: This unit is equipped with an internal combustion engine and must not be used on or near any unimproved forest-covered, brush-covered or grass-covered land unless the engine's exhaust system is equipped with a spark arrester meeting applicable local or state laws (if any). If a spark arrester is used, it must be maintained in effective working order by the operator.

In the State of California the above is required by law (Section 4442 of the California Public Resources Code). Other states may have similar laws. Federal laws apply on federal lands.

CHECK THE TIRES

Check the air pressure in the tires. Tires with too much air pressure will cause the unit to ride rough. Also, the wrong air pressure will keep the mower housing from cutting level. The correct air pressure is shown on the side of the tires. If the air pressure is not shown, inflate the tires from 10 to 12 PSI (0.7 to 0.85 kg/cm²).

HOW TO CHECK THE MOWER HOUSING

Make sure the level of cut set at the factory is still correct. After you mow a short distance, look at the area that was cut. If the mower housing does not cut level, see the instructions on "How To Level The Mower Housing" in the maintenance section of this instruction book.

OPERATION

INTRODUCTION TO THE OPERATION OF THE UNIT

This part of the instruction book gives the location and use of the different controls. For the safety of the operator, follow the instructions on how to operate the controls.

THE THROTTLE CONTROL

Use the throttle control to increase or decrease the speed of the engine. To start a cold engine, push the lever to the right and into the CHOKE position. For normal operations, move the lever to the FAST position. The engine governor is set at the factory for maximum performance. Do not adjust the governor to increase the speed of the engine.

HOW TO USE THE BLADE ENGAGEMENT CONTROL

The blade engagement control is next to the steering wheel. Use the blade engagement control to rotate the blade or to operate a snow thrower attachment.

1. Before you start the engine, make sure the control lever is in the DISENGAGE position.
2. Move the control lever to the ENGAGE position to rotate the blade.
3. Move the control lever to the DISENGAGE position to stop the rotary blade. Before you leave the operator's position, make sure the blade has stopped rotating.
4. Before you ride the unit across a sidewalk or a road, move the control lever to the DISENGAGE position.



WARNING: Always keep your hands and feet away from the blade, deflector opening, and the mower housing when the engine runs.

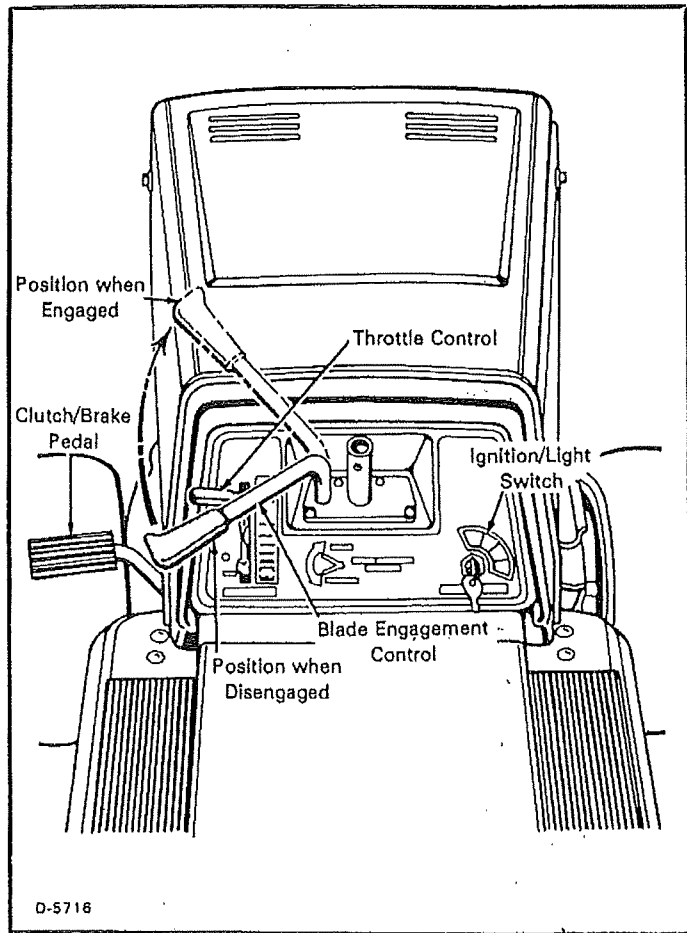

HOW TO USE THE SHIFT LEVER

To change the forward speed or the direction of the unit, follow the steps below:

1. Completely push the clutch/brake pedal forward.



WARNING: Before you move the shift lever in or out of NEUTRAL or REVERSE, fully apply the clutch/brake pedal.

2. Move the shift lever to FIRST or REVERSE.
3. Slowly release the clutch/brake pedal. Do not ride with your foot on the clutch/brake pedal.
4. While the unit moves forward, you can select any forward speed. Just move the shift lever to the next faster or next slower speed. You do not have to use the clutch/brake pedal.
5. The shift lever positions for operation of your unit are shown in the chart below.

FUNCTION	4 SPEEDS	6 SPEEDS
Trimming	1	1
Small areas	1	1
Bagging grass	1 or 2	1 or 2
Normal mowing	2 or 3	2 or 3
Easy mowing	4	4 or 5
Transport	4	6

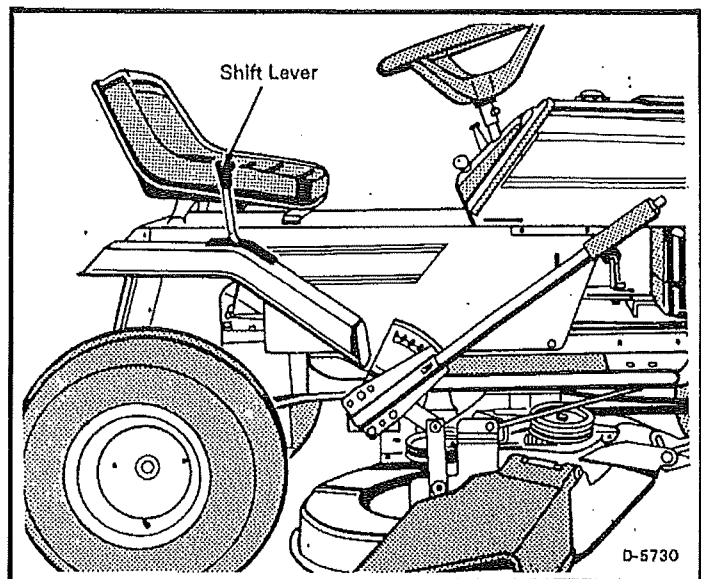

OPERATION

HOW TO SET THE PARKING BRAKE

1. Completely push the clutch/brake pedal forward.
2. Lift the parking brake lever.
3. Remove your foot from the clutch/brake pedal and then release the parking brake lever.
4. To release the parking brake, completely push the clutch/brake pedal forward. The parking brake will automatically release.



WARNING: Before you leave the operator's position, move the shift lever to the neutral (N) position. Set the parking brake. Move the blade engagement control to the DISENGAGE position. Stop the engine and remove the ignition key.

HOW TO USE THE MOWER HOUSING LIFT LEVER

The mower housing lift lever is on the right side of the unit as shown. Use the lift lever to raise or lower the mower housing. To operate the lift lever, push the button on top of the lever to release the lever. Move the lever forward to lower the mower housing and back to raise the mower housing.

THE IGNITION SWITCH: To start the engine, put the key in the ignition switch and turn to the START position. Release the key when the engine begins to run.

THE HEADLIGHT SWITCH: The headlight switch is the first part of the ignition switch. To use the headlights without starting the engine, turn the key to the position for the lights. To use the lights with the engine running, turn the key to the position for the lights.

HOW TO STOP THE UNIT

1. Push the pedal completely forward to stop the unit. Keep your foot on the pedal.
2. Move the blade engagement control to the DISENGAGE position.
3. Move the shift lever to the NEUTRAL position.
4. Set the parking brake.



WARNING: Make sure the parking brake will hold the unit.

5. Move the throttle control to the SLOW position.
6. To stop the engine, turn the ignition key to the OFF position. Remove the key.

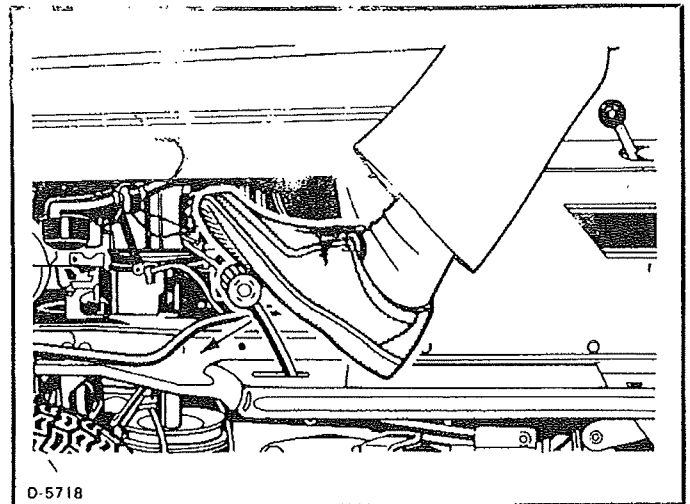
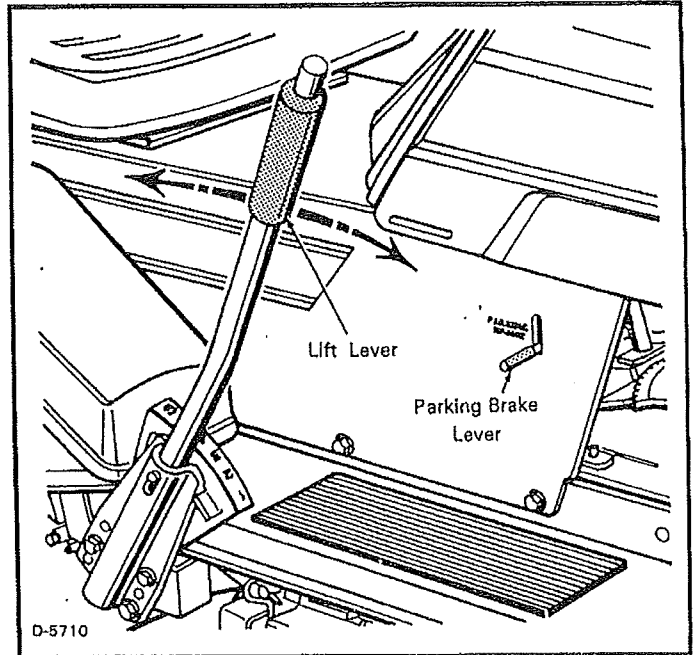

OPERATION

HOW TO START THE ENGINE

NOTE: Read the engine manufacturer's instructions. Before starting the engine, fill the engine with the correct oil and gas.



WARNING: The electrical system has an operator presence system that includes a sensor switch mounted in the seat. These components tell the electrical system if the operator is sitting on the seat. For your protection, always make sure this system operates correctly. This system will stop the engine when the operator leaves the seat if the blade engagement control is engaged.

1. Check the oil.
2. Fill the fuel tank with regular unleaded gasoline. Make sure the gasoline is clean. Leaded gasoline will increase deposits and shorten the life of the valves.
NOTE: Do not use gasohol or methanol. Do not use premium unleaded gasoline.



WARNING: Always use a safety gasoline container. Do not smoke when adding gasoline to the fuel tank. When inside an enclosure, do not add gasoline. Before you add gasoline, stop the engine and let the engine cool for several minutes.

3. Sit in the seat. Push the clutch/brake pedal completely forward. Keep your foot on the pedal.
4. Move the shift lever to the neutral (N) position.
5. Make sure the blade engagement control is in the DISENGAGE position.
6. Move the throttle control to the CHOKE position.
7. Turn the ignition key to the START position. Release the key when the engine starts.

NOTE: If the engine does not start after four or five tries, move the throttle control to the FAST position. Again try to start the engine. If the engine will not start, see the TROUBLE SHOOTING CHART.

8. Slowly move the throttle control to the SLOW position.
9. Let a cold engine run for several minutes. Begin work when the engine is warm. To start a hot engine, move the throttle control to a position between FAST and SLOW.

HOW TO OPERATE WITH THE MOWER HOUSING



WARNING: The deflector is a safety device. Do not remove the deflector. The deflector forces the discharged material toward the ground. Always keep the deflector in the down position. If the deflector is damaged, replace it with a factory replacement part.

1. Start the engine.
2. Move the lift lever to a height of cut position. In high or thick grass, cut the grass in the high position first and then lower the mower housing to a lower position.
3. Move the throttle control to the SLOW position.
4. Move the blade engagement control to the ENGAGE position.
5. Push the clutch/brake pedal completely forward.
6. Move the shift lever to one of the speed settings.
IMPORTANT: When you mow in heavy grass or mow with a bagger, put the shift lever in the slowest speed.
7. Slowly release the clutch/brake pedal.
8. Move the throttle control to the FAST position. If you need to go faster or slower, stop the unit and move the shift lever to another speed setting.



WARNING: For better control of the unit, always select a safe speed.

HOW TO OPERATE THE UNIT ON HILLS



WARNING: Do not ride up or down slopes that are too steep to back straight up. Never ride the unit across a slope. See the "Slope Guide" in the back of this book for information on how to check slopes.

1. Before you ride up or down a hill, move the shift lever to the slowest speed.
2. Do not stop or change speed settings on a hill. If you must stop, quickly push the clutch/brake pedal forward and set the parking brake.
3. To start again, make sure the shift lever is the slowest speed. Move the throttle control to the SLOW position. Slowly release the pedal.
4. If you must stop or start on a hill, always have enough space for the unit to roll when you release the brake and engage the clutch.
5. Be very careful when you change directions on a hill. When on a slope or in a turn on a hill, move the throttle control to the SLOW position to help prevent an accident.

ATTACHMENTS

This unit can use many different attachments. See the attachment page in this book. This unit can pull attachments like a lawn sweeper, a lawn aerator, or a hopper spreader. This unit can not use attachments that engage the ground like a plow, a disk harrow, or a cultivator.

MAINTENANCE

Use the following maintenance section to keep your unit in good operating condition. All maintenance information for the engine is in the "Engine Owner's Manual". To help prevent an accident, follow the maintenance instructions and the safety rules.



WARNING: Before you make an inspection, adjustment (except carburetor), or repair, disconnect the wire from the spark plug.

HOW TO CLEAN AND CHECK THE BATTERY



WARNING: To prevent sparks, disconnect the black battery cable from the positive (+) terminal before you disconnect the red cable.



WARNING: The battery contains sulphuric acid which is harmful to the skin, eyes and clothing. If the acid gets on the body or clothing, wash with water.

1. Remove the black cable from the negative (-) terminal.
2. Remove the red cable from the positive (+) terminal.
3. Remove the battery clip from the frame.
4. Remove the battery from the unit.
5. Wash the battery with a solution of one gallon of water and four tablespoons of baking soda (sodium bicarbonate). Make sure the solution does not get into the battery cells.
6. Clean the terminals and the ends of the cables with a wire brush.
7. Install the battery. See "How To Install The Battery".
8. Check the level of the battery acid. The battery acid must touch the bottom of the vent. If the battery acid has fallen below the correct level, add water to the correct level. Do not add battery acid to a charged battery or the result can be an explosion.

IMPORTANT: The battery will be damaged if the battery acid is not kept at the correct level.

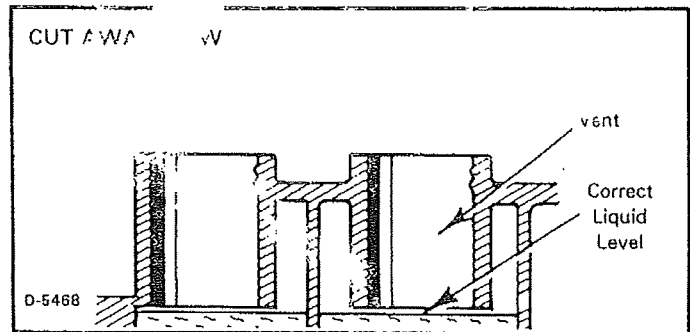
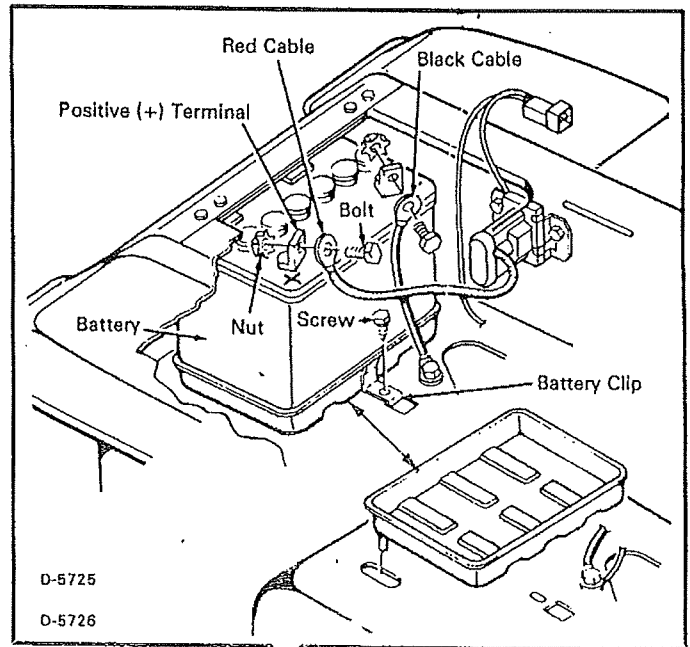

HOW TO CHECK THE MUFFLER

Check the muffler every 50 hours. Make sure the muffler is correctly mounted and is not loose. If the muffler is worn or burnt, replace with a new muffler. A worn muffler is a fire hazard and also can damage the engine.

If you mount a spark arrestor to the muffler, also check the spark arrestor when you check the muffler. If the spark arrestor is worn or damaged, replace it with a new spark arrestor.

MAINTENANCE

HOW TO CHECK AND ADJUST THE CLUTCH

If the unit will not move when the clutch is engaged, the motion drive belt is loose. Check the clearance between the rear of the pedal and the back of the hole as shown. If there is more or less than the clearance shown in the illustration, adjust the pedal as follows.

1. Disconnect the adjustable nut from the lever assembly as shown.
2. Turn the adjustable nut clockwise to decrease the length of the clutch rod. This adjustment will decrease the clearance at the pedal.
3. Assemble the adjustable nut to the lever assembly. Check the clearance at the pedal.
4. After making an adjustment to the pedal, check the brake rod as described in the instructions on "How To Check And Adjust The Drive Brake."

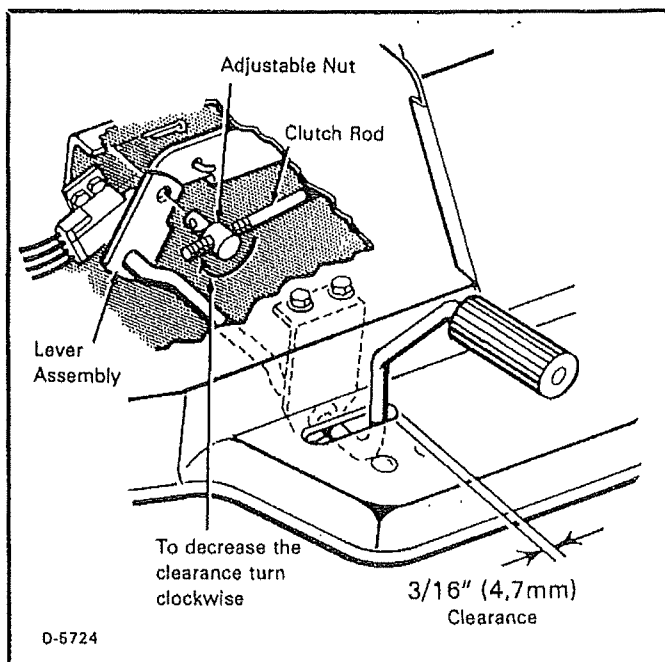

HOW TO CHECK AND ADJUST THE DRIVE BRAKE

Completely push the clutch/brake pedal forward. Set the parking brake. Move the shift lever to the neutral (N) position. Push the unit. If the rear wheels rotate, adjust or replace the brake pads. Adjust the drive brake as follows.

1. The location of the brake is on the right side of the gearbox.
2. Make sure the parking brake is set and the shift lever is in neutral (N). Turn the hex nut in a clockwise direction until the rear wheels do not turn when the unit is pushed forward.
3. Release the parking brake and push the unit. If the unit does not roll, turn the hex nut in a counterclockwise direction until the unit rolls.
4. Set the parking brake. Push the unit. If the rear wheels do not turn, the brake is correctly adjusted. Release the parking brake.

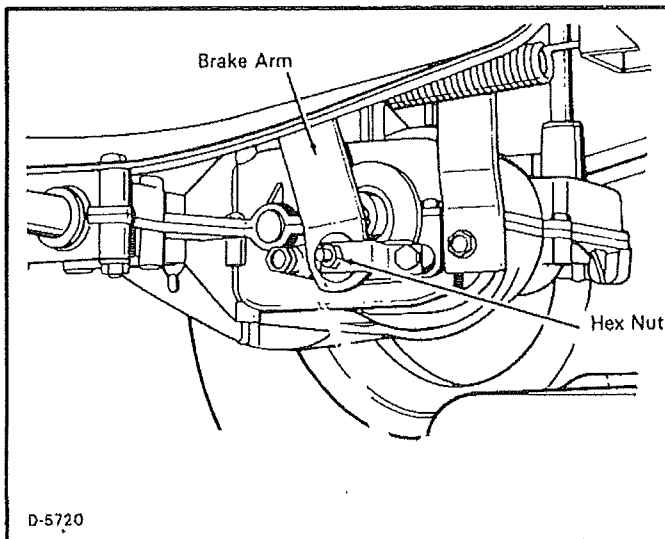

WARNING: If you cannot correctly adjust the drive brake, replace the brake pads. Correct replacement parts and assistance are available from an authorized service center.

CHECK THE TIRES

Check the air pressure in the tires. Tires with too much air pressure will cause the unit to ride rough. Also, the wrong air pressure will keep the mower housing from cutting level. The correct air pressure is shown on the side of the tires. If the air pressure is not shown, inflate the tires from 10 to 12 PSI (0.7 to 0.85 kg/cm²).

MAINTENANCE

HOW TO ADJUST THE SHIFT LEVER

NOTE: The shift cover was removed to help show the shift guide.

1. Move the shift lever to the NEUTRAL position. Carefully pull the shift cover away so that you can see the shift guide.
2. Carefully push the shift lever towards the seat until you feel the spring begin to extend. Measure the distance between the shift lever and the shift guide as shown. The distance must be approximately 1/8" to 3/16" (3,1mm to 4,7mm).
3. If the distance between the shift lever and the guide is incorrect, disconnect the adjustable nut at the shift lever as shown.
4. Check and adjust the clutch/brake pedal. See the instructions How To Check and Adjust The Clutch.
5. Turn the adjustable nut at the shift lever clockwise to decrease the distance between the shift lever and the guide or counterclockwise to increase the distance. Connect the adjustable nut to the shift lever.
6. Check the distance between the shift lever and the guide. See Step 2. If the distance is incorrect, repeat Steps 3 and 5.

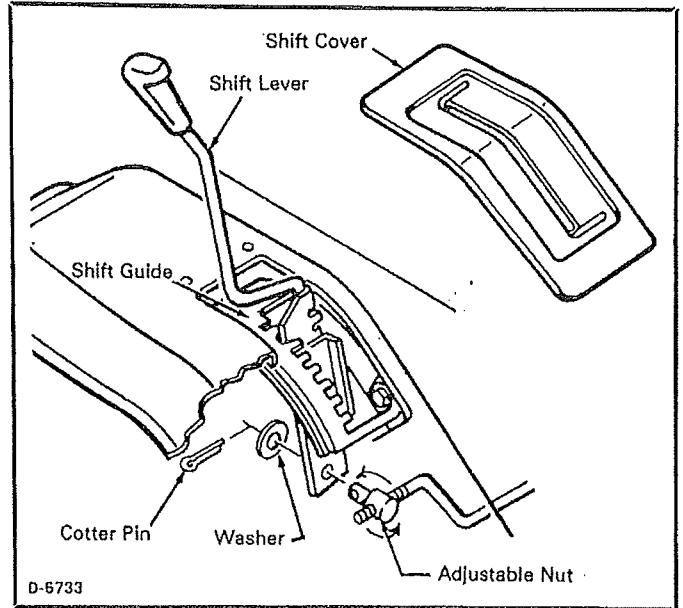

HOW TO CHECK AND ADJUST THE SHIFT GATE

If it is difficult to change gears, the shift guide needs adjusting.

1. Set the parking brake.
2. Loosen the two bolts at the shift guide as shown.
3. Move the shift lever to the highest gear.
4. With the shift lever in the highest gear tighten the two bolts at the shift guide.
5. Move the shift lever to the NEUTRAL position. Release the parking brake. Push the unit to make sure the rear wheels will turn.

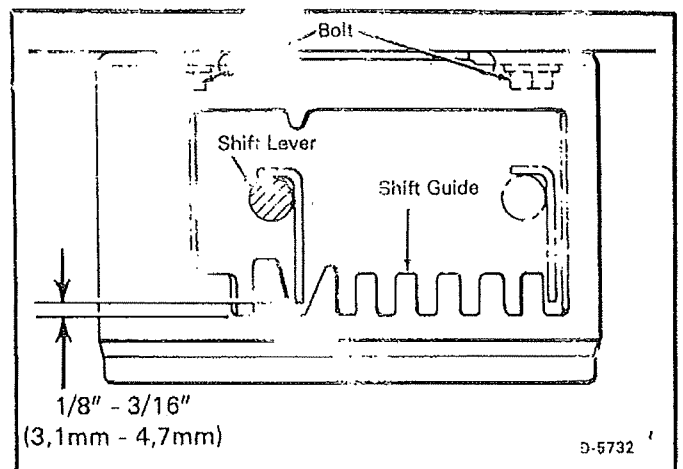

MAINTENANCE

HOW TO CHECK AND ADJUST THE BLADE ENGAGEMENT CONTROL



WARNING: To prevent an injury, the blade engagement control must operate correctly.

1. Stop the engine. Disconnect the wire from the spark plug.
2. Before you adjust the blade engagement control lever, check and level the mower housing. See "How To Level The Mower Housing."
3. Set the height of the mower housing in the lowest position.
4. Move the blade engagement control to the ENGAGE position. Check the blade drive spring. The end of the plastic indicator must be aligned with the last coil of the blade drive spring.

NOTE: To measure the spring without the plastic indicator, put the blade engagement control in the DISENGAGE position. Measure the length of the spring coils. Move the blade engagement control to the ENGAGE position and again measure the length of the coils. In correct adjustment, the length of the coils will be 3/8 inch (9mm) longer. If an adjustment is needed, disconnect the control rod and follow the instructions in step 5.

5. If the plastic indicator is not aligned with the last spring coil, an adjustment is needed. Move the blade engagement control to the DISENGAGE position. Disconnect the control rod from the pivot bracket. Turn the adjustable nut clockwise to increase the length of the coils. Turn the adjustable nut counterclockwise to decrease the length of the coils.
6. Connect the control rod to the pivot bracket. Move the blade engagement control to the ENGAGE position. Check the adjustment of the blade drive spring.
7. Move the blade engagement control to the DISENGAGE position. Check the operation of the blade brake. Rotate the pulley with your hand. Make sure the blade brake pads press tightly against the pulleys.
8. Move the blade engagement control to the ENGAGE position. Check the blade brake pads. If the blade brake pads are excessively worn or damaged, replace the blade brake pad assemblies. Correct replacement parts and assistance are available from an authorized service center.
9. Mow for a short distance and again check the operation of the blade engagement control.
10. When you move the blade engagement control to the DISENGAGE position, all movement will stop within five seconds if the adjustment is correct. If all movement does not stop, again adjust the blade engagement control beginning with the first step. If you need assistance, take the unit to an authorized service center.
11. If you replace the mower drive belt, adjust the blade engagement control lever.

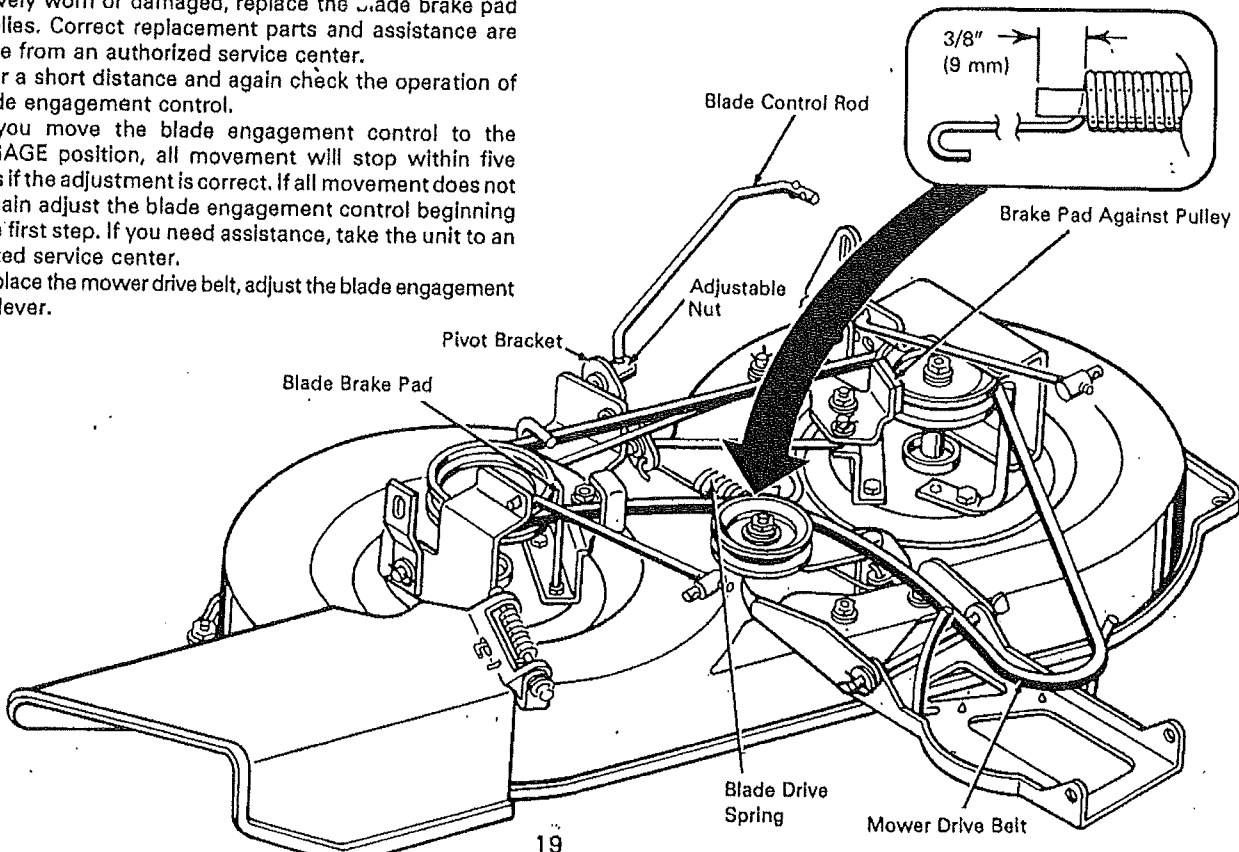
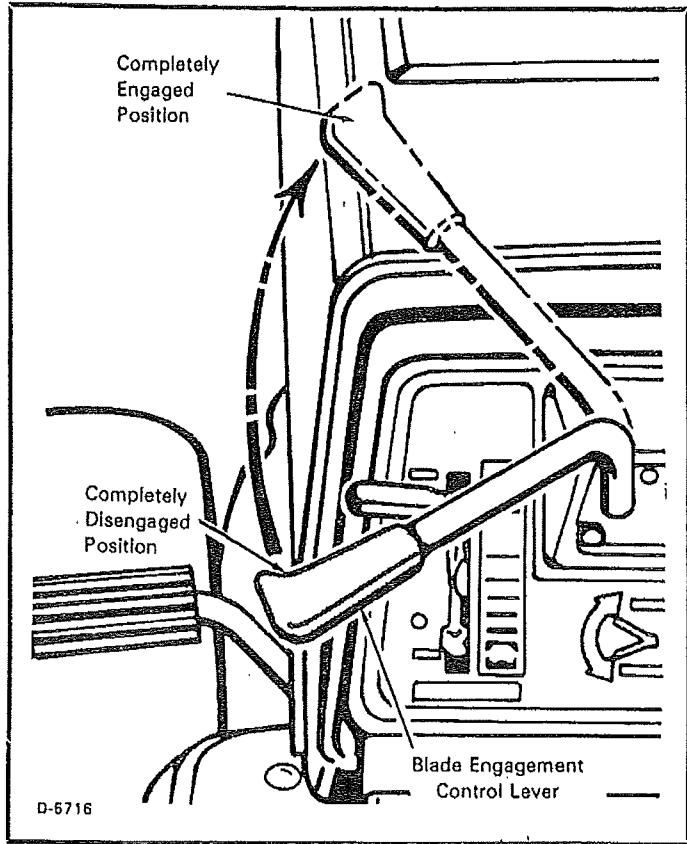

MAINTENANCE

HOW TO REMOVE THE MOWER HOUSING

1. Move the lift lever to the lowest position.
2. Move the blade engagement control lever to the DISENGAGE position.
3. Remove the hair pins and the washers from the adjusting rods. See illustrations "C" and "D" below.
4. Remove the hair pins and the washers from the suspension link and the adjuster plate. See illustrations "A" and "B" below.
5. Remove the hair pin and washer from the blade control rod. See illustration "E" below.
6. Disconnect the front hanger from the axle support. See illustration "F" below.
7. Remove the mower drive belt from the stack pulley.
8. Pull the mower housing away from the right side of the unit.

HOW TO INSTALL THE MOWER HOUSING

1. Push the mower housing under the right side of the unit.
2. Put the mower drive belt around the stack pulley. Make sure the "V" side of the mower drive belt is against the stack pulley. Also, make sure the mower drive belt is not twisted.

3. Attach the front hanger to the axle support with the hanger rod. Fasten with the fasteners as shown. See illustration "F" below.
4. Make sure the mower drive belt is between the stack pulley and the belt guide.
5. Fasten the control rod to the blade engagement control with the washer and hair pin. See illustration "E" below.
6. Attach the suspension link and the adjuster plate to the lifter assembly. Fasten with the washers and hair pins. See illustrations "A" and "B" below.
7. Attach the right and the left adjusting rods to the suspension brackets. Fasten with the washers and hair pins. See illustrations "C" and "D" below.
8. Move the blade engagement control to the ENGAGE position. Make sure the mower drive belt is inside all the belt guides.
9. Check the operation of the blade engagement control. See the instructions on "How To Check And Adjust The Blade Engagement Control".
10. Make sure the mower housing is level. See the instructions on "How To Level The Mower Housing".

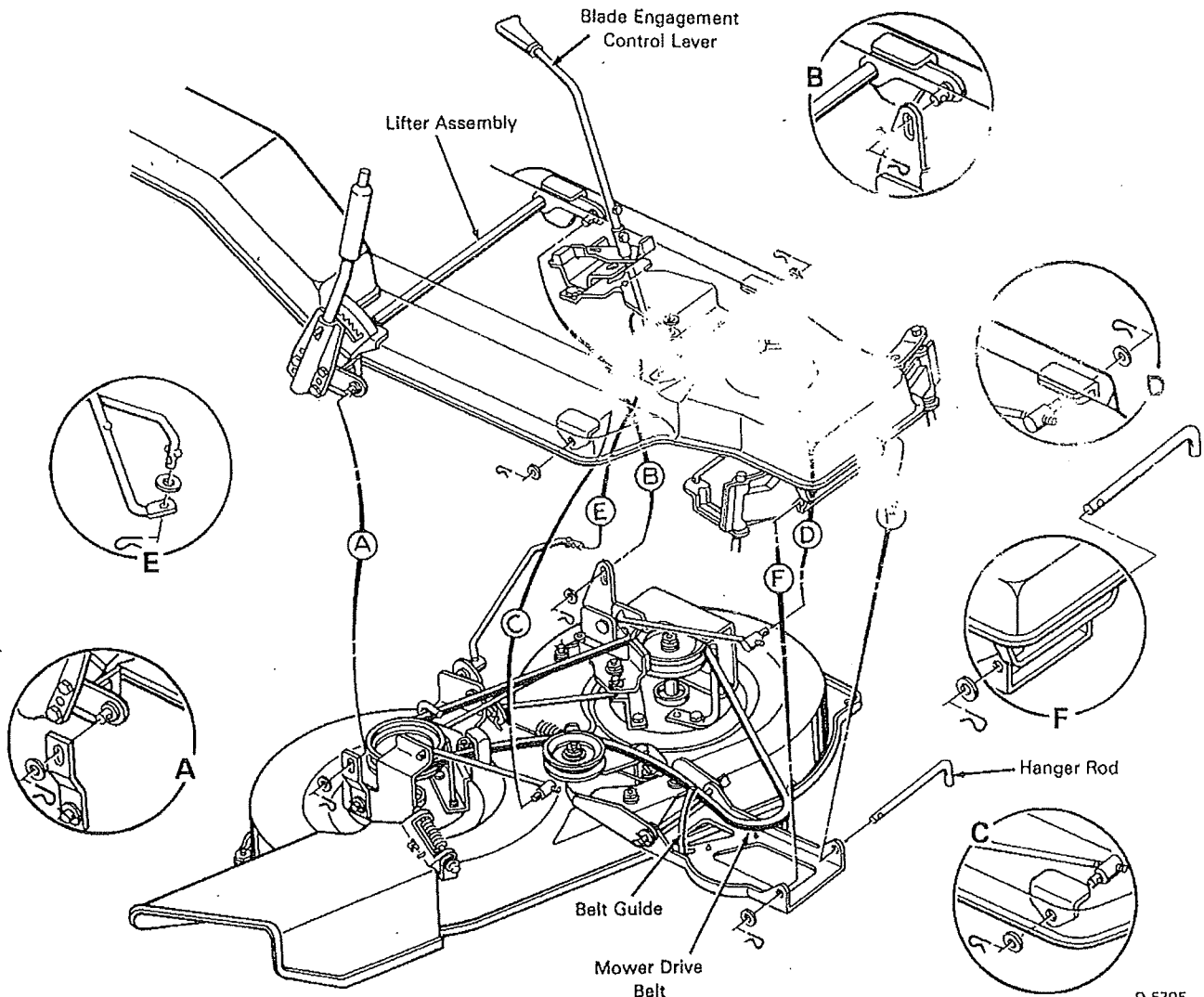

SERVICE AND ADJUSTMENTS

HOW TO LEVEL THE MOWER HOUSING



WARNING: Before you make an inspection, adjustment, or repair to the unit, disconnect the wire to the spark plug. Remove the spark plug wire to prevent the engine from starting by accident.

1. Make sure the unit is on a hard level surface.
2. Check the air pressure in the tires. If the air pressure is incorrect, the mower housing will not cut level. Make sure the tires are inflated to the amount shown on the side of the tire. If the air pressure is not shown, inflate the tires from 10 to 12 psi. (0.7 to 0.85 kg/cm²).
3. Move the lever for the blade engagement control to the DISENGAGE position. Move the lift lever to the middle cutting height position.
4. There are two adjustment procedures below that will level the mower housing.

THE FRONT TO BACK ADJUSTMENT

Use a ruler and measure the distance from the level surface to the bottom of the mower housing. Measure from the locations indicated by the "X" marks at points B and D. In correct adjustment, the front of the mower housing at point B will be 1/4" (6 mm) higher than the back of the mower housing at point D.

1. Disconnect both adjuster rods from the adjuster rod brackets as shown.
2. Turn the adjustable nut clockwise to lower the front or counterclockwise to raise the front of the mower housing.
3. Connect the left adjuster rod to the adjuster rod bracket. Check the housing for the correct adjustment. Fasten the adjustable nut with the washer and hair pin.
4. Repeat the above steps for the right side using the "X" marks at points A and C.

THE SIDE TO SIDE ADJUSTMENT

Use a ruler and measure the distance from the level surface to the bottom of the mower housing. Measure from the locations indicated by the "X" marks at points A and B. In correct adjustment, the mower housing at points A and B must be within 1/8" (3 mm) of the same height. If the difference in the measurement is more than 1/8" (3 mm), adjust as follows.

1. Disconnect the adjuster plate from the mower housing as shown.
2. Move the adjuster plate to the front to raise or to the back to lower the left side of the mower housing. Connect the adjuster plate.
3. Check the housing for the correct adjustment. If necessary, repeat the adjustment.

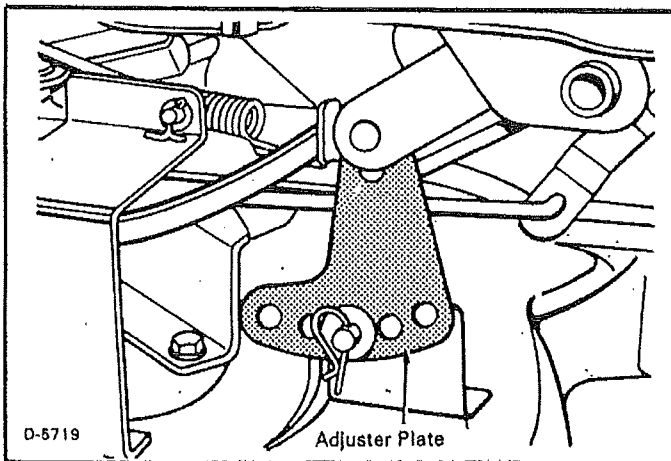
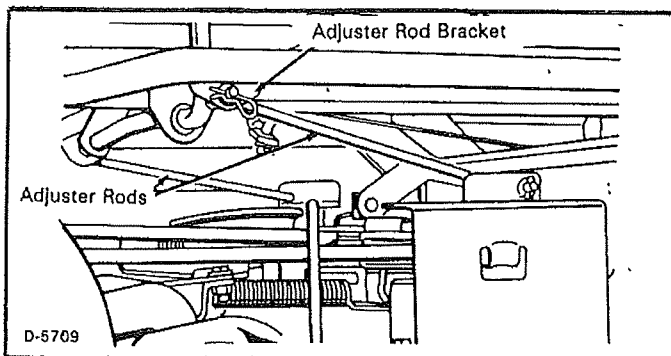
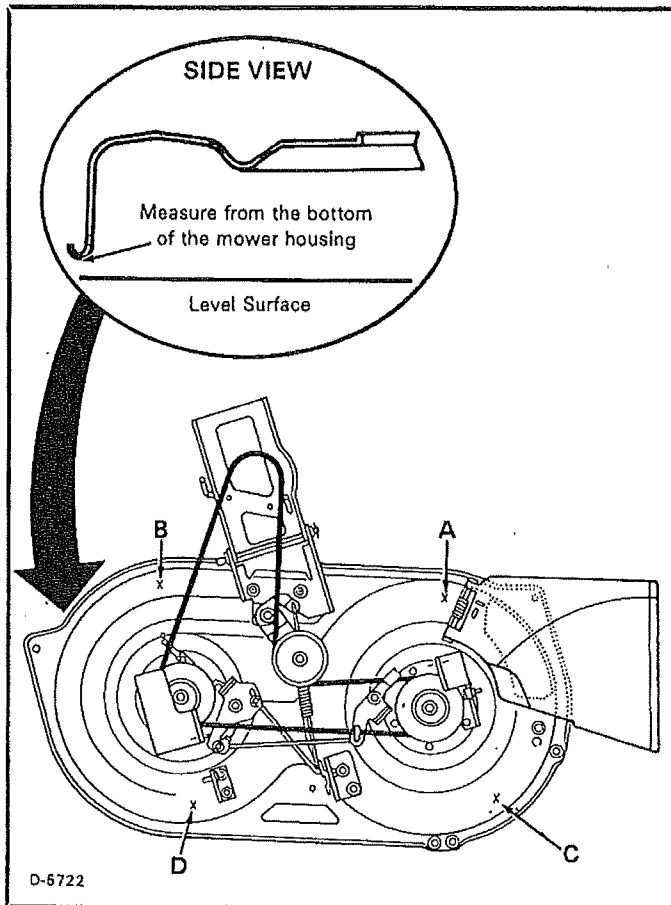

MAINTENANCE

BLADE SERVICE



WARNING: Before you inspect the blade, disconnect the wire to the spark plug. If the blade hits an object, stop the engine. Disconnect the wire to the spark plug. Check the unit for damage.

Frequently check the blade for excessive wear, cracks, or other damage. Frequently check the nut that holds the blade. Keep the nut tight. If the blade hits an object, stop the engine. Disconnect the wire to the spark plug. See if the blade is bent or damaged. Check the blade adapter for damage. Before you operate the unit, replace damaged parts with a replacement part from the factory. Every three years, have an authorized service person inspect the blade or replace the old blade with a replacement blade from the factory. Keep a sharp edge on the blade. A blade that is not sharp will cause the tips of the grass to become brown.

HOW TO REMOVE AND INSTALL THE BLADE



WARNING: Before you remove the blade, disconnect the wire to the spark plug. The blade has sharp edges. When you hold the blade, use gloves or cloth material to protect your hands.

1. Remove the mower housing. See the instructions on "How To Remove The Mower Housing".
2. Use a piece of wood to keep the blade from rotating.
3. Remove the nut that holds the blade.
4. Check the blade and the blade adapter according to the instructions for "Blade Service". Replace a badly worn or damaged blade with a replacement blade from the factory.
5. Clean the top and bottom of the mower housing. Remove all the grass and debris.
6. Mount the blade and blade adapter on the mandrel as shown.
7. Mount the blade so that the hi-lift edges are up as shown. If the blade is upside down, the blade will not cut correctly and can cause an accident.
8. Fasten the blade with the original washers and nut. Make sure the outside rim of the belleville washer is against the blade as shown.
9. Tighten the nut that holds the blade to a torque of 30 foot pounds (41,5N-m).



WARNING: Always keep the nut tight that holds the blade. A loose nut or blade can cause an accident.

HOW TO SHARPEN THE BLADE



WARNING: Vibration can be caused if the blade is not correctly balanced or if the blade is damaged. A blade that is damaged with cracks can break and cause an accident.

1. Sharpen the blade two times a year or every 25 hours.
2. Remove the blade according to the instructions in "How To Remove And Install The Blade".
3. Clean the blade with a brush, soap and water. Check the blade. Look for cracks, nicks, or other damage. Replace a badly worn or damaged blade with a replacement blade from the factory.
4. Sharpen the blade with a file. Make sure you keep the original bevel angle.
5. Make sure the blade is balanced. Use a screwdriver and hold the blade parallel to the ground as shown. A blade that is balanced will stay parallel to the ground. If the blade is not balanced, the heavy end will rotate toward the ground. Sharpen the heavy end until the blade is balanced.
6. A new blade will cut better than a badly worn blade. Every three years, have an authorized service person inspect the blade or replace the old blade with a replacement blade from the factory.
7. Assemble the blade according to the instructions "How To Remove And Install The Blade".

F-90785

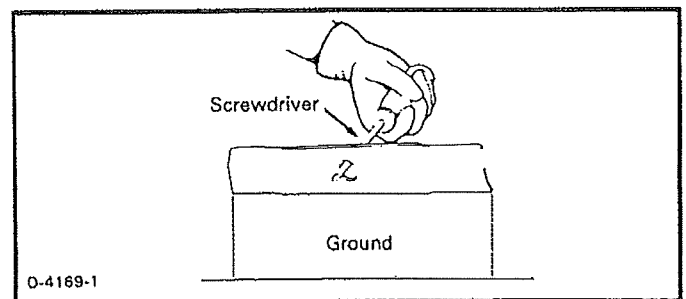
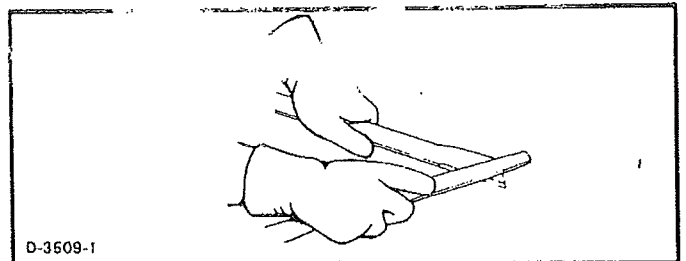
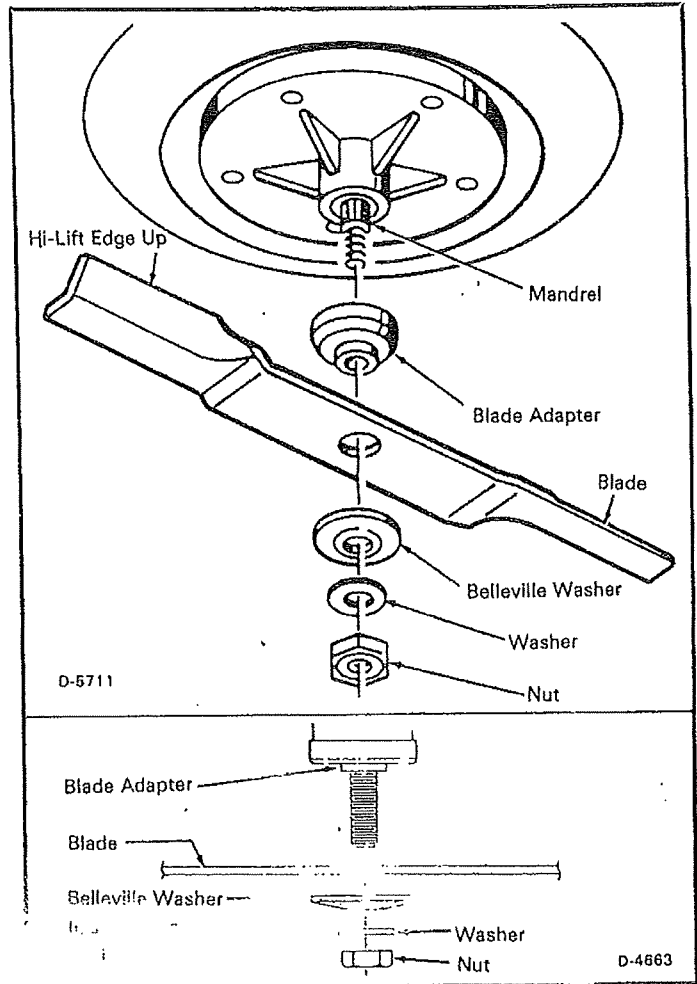

MAINTENANCE

HOW TO REPLACE THE MOTION DRIVE BELT

1. Remove the mower housing. See the instructions on "How To Remove The Mower Housing" in this instruction book.
2. Completely push the pedal forward and engage the parking brake.
3. Remove the idler pulley.
4. Loosen the belt guides that are around the drive pulley.
5. Remove the belt from the drive pulley and the stack pulley.
6. Remove the two screws from the support bracket as shown. Remove the support bracket.
7. Disconnect the shifter link as shown.
8. Remove the motion drive belt. Replace the drive belt with a replacement belt from the factory.
9. Install the motion drive belt on the top pulley of the stack pulley. Make sure that the "V" side of the belt is against the pulley.
10. Install the end of the belt around the drive pulley.
11. Tighten the belt guides that are around the drive pulley as shown.
12. Put the belt around the idler pulley. Assemble the idler pulley. Fasten the pulley with the hex nut. Make sure the flat side of the belt is against the idler pulley as shown. Also, make sure the belt is not twisted.
13. Connect the shifter link as shown.
14. Assemble the support bracket. Fasten with the two screws as shown.
15. Make sure the motion drive belt is inside all the belt guides as shown.
16. Before you use the unit, check the pedal adjustment. See the instructions on "How To Check And Adjust The Clutch".
17. Install the mower housing. See the instructions on "How To Install The Mower Housing" in this instruction book.

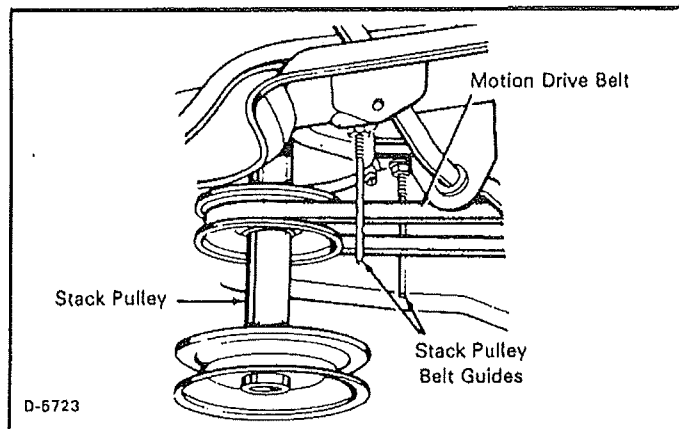
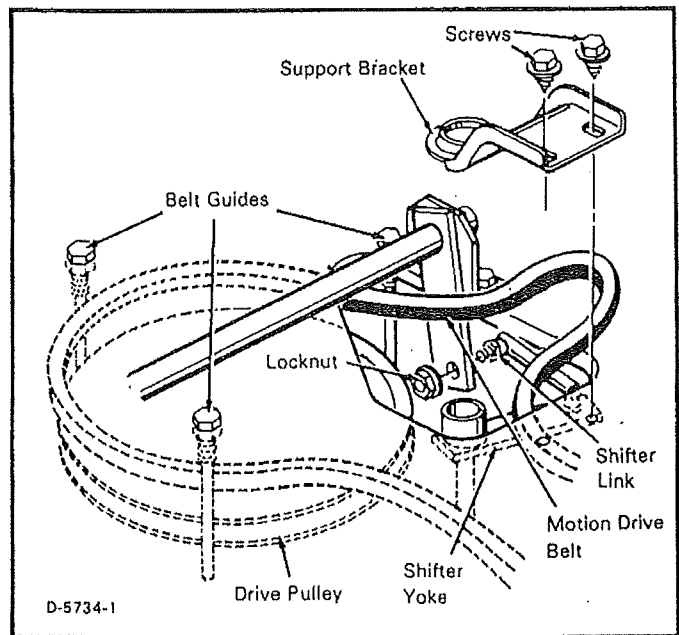
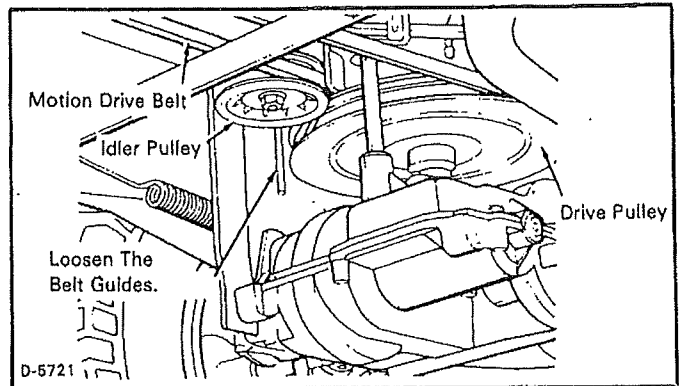

MAINTENANCE

HOW TO REPLACE THE MOWER DRIVE BELT

1. Remove the mower housing. See the instructions on "How To Remove The Mower Housing".
2. Pull the belt retainer away from the idler pulley and remove the mower drive belt.
3. Pull the belt retainer away from the right mandrel pulley and remove the mower drive belt.
4. Remove the mower drive belt from the left mandrel pulley.
NOTE: Replace the mower drive belt with a factory replacement belt.
5. Install the new mower drive belt. Pull the belt retainer away from the right mandrel pulley. Put the belt around the right mandrel pulley.
6. Pull the belt retainer away from the idler pulley. Put the flat side of the mower drive belt around the idler pulley.
7. Put the belt around the left mandrel pulley.
8. Make sure the "V" side of the mower drive belt is against the mandrel pulleys as shown.
9. Make sure the mower drive belt is under the end of the cross link rod as shown.
10. Make sure the mower drive belt is inside all the belt guides.
11. Install the mower housing. See the instructions on "How To Install The Mower Housing".
12. Before you mow, check the blade engagement control. See the instructions on "How To Check And Adjust The Blade Engagement Control".

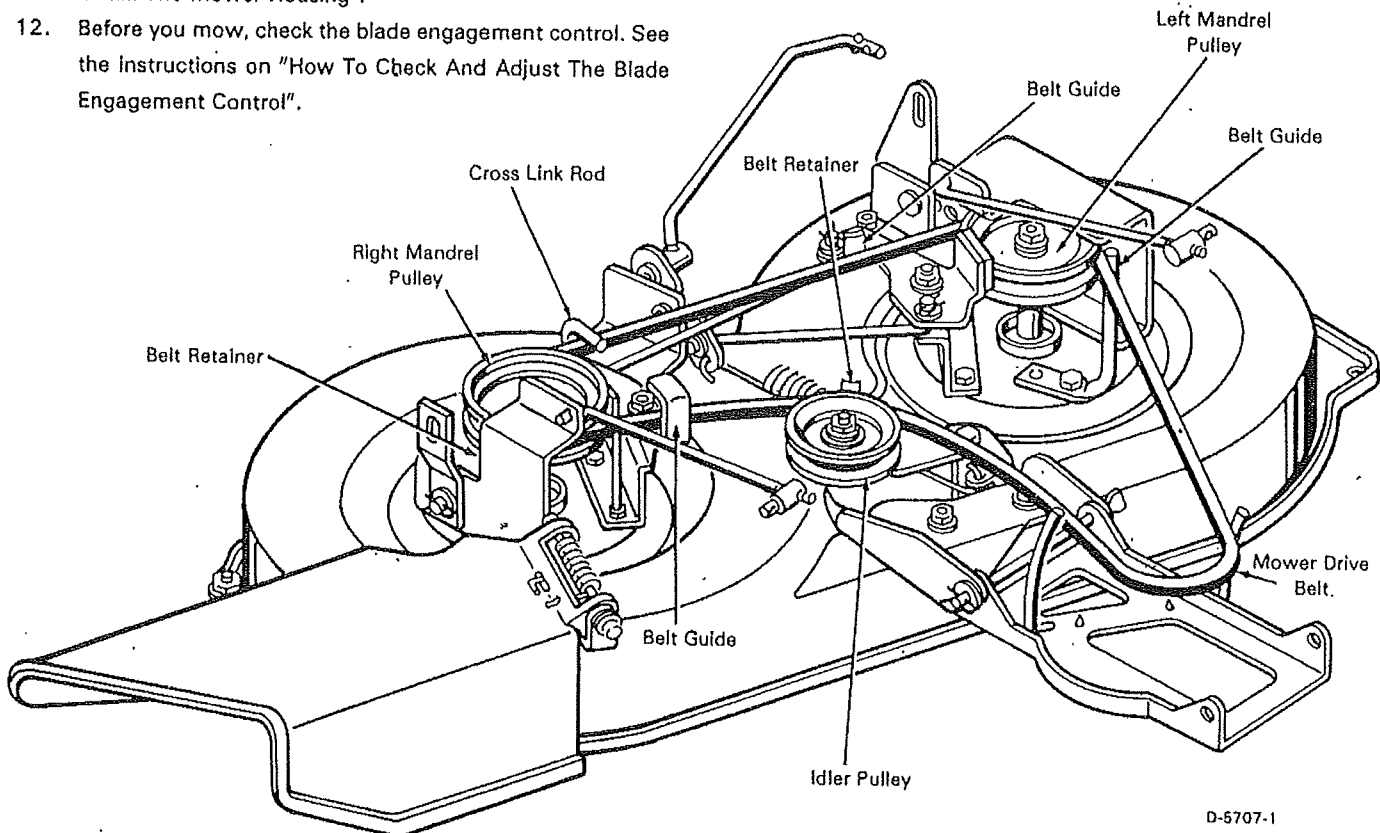

D-5707-1

MAINTENANCE

WHERE TO LUBRICATE



Lubricate the areas shown with engine oil.



Apply grease with a brush to the areas shown.

NOTE; Apply grease to the steering gear assembly.

IMPORTANT: If the unit is operated in dry areas that have sand, use a dry graphite spray to lubricate the unit.

HOW TO START WITH A WEAK BATTERY

If the battery is too weak to start the engine, the battery needs to be charged. If "Jumper Cables" are used to start the engine in an emergency, follow the procedure below.

NOTE: The unit is equipped with a 12 volt negative to ground system. Also, the other vehicle must have a 12 volt negative to ground system.



WARNING: Do not smoke. The fumes from the battery acid can cause an explosion. Keep the battery away from any flames or sparks. To prevent sparks, fasten the red jumper cable to the positive (+) terminal before connecting the black jumper cable.

1. Put a wet cloth over the vent caps of each battery.
2. Connect each end of the RED "Jumper Cable" to the positive (+) terminals of each battery. Make sure you do not touch the chassis with the cables.
3. Connect one end of the BLACK "Jumper Cable" to the negative (-) terminal of the charged battery.
4. Connect the other end of the BLACK "Jumper Cable" to the engine block.
5. Start the engine that has the weak battery last. Allow the engine to run.
6. To disconnect the "Jumper Cables", reverse the above steps.

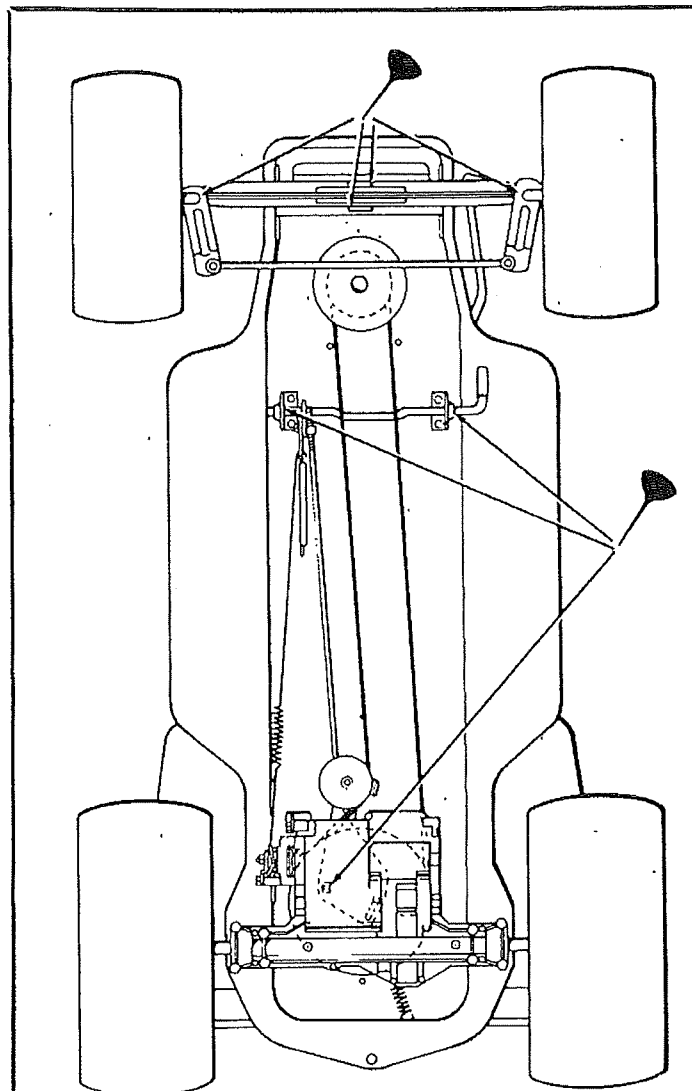

D-5706

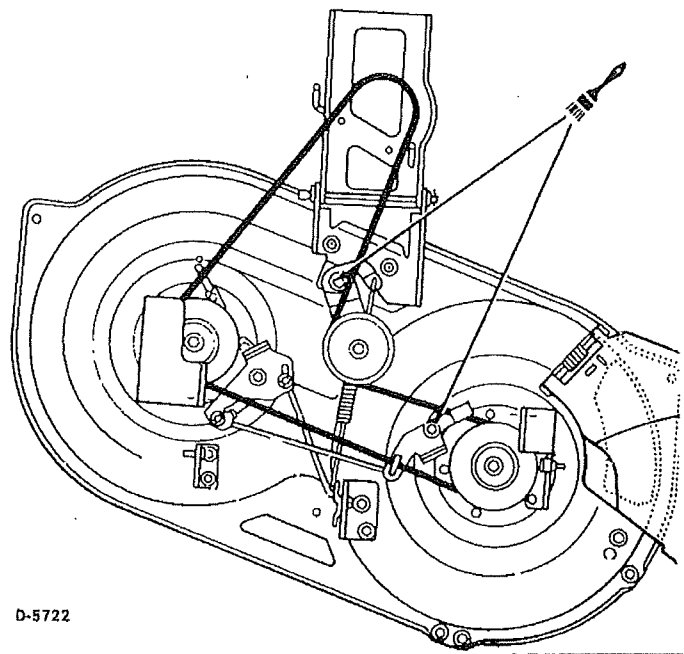

D-5722

MAINTENANCE

CHECK THE FUEL FILTER

CAUTION: Before you replace the fuel filter or the fuel line, the fuel tank must be empty.

If the fuel filter is dirty, the engine will run rough and have less performance. Remove the old filter. Replace the old filter with a new filter. Use a factory replacement part.

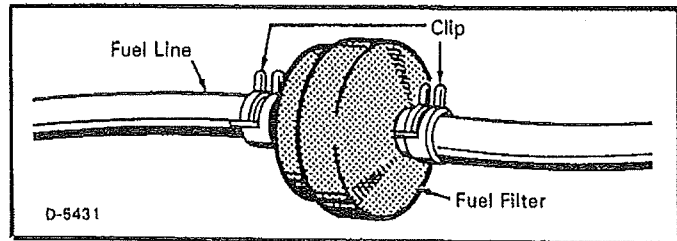

HOW TO REPLACE THE LIGHT BULB

1. Raise the tractor hood.
2. Pull the light socket from the bezel.
3. Pull the light bulb from the socket.
4. Install a new light bulb. Push the socket into the bezel.

HOW TO CLEAN THE MOWER HOUSING



WARNING: Before you clean the mower housing, stop the engine and disconnect the wire to the spark plug.

Grass and other debris on top of the mower housing can keep the belt from working correctly. Clean the mower housing as follows.

1. Move the lever for the blade engagement control to the ENGAGE position.
2. Clean the top of the mower housing.
3. Move the lever for the blade engagement control to the DISENGAGE position.
4. Again clean the top of the mower housing.
5. After you cut the grass, clean the bottom of the mower housing.

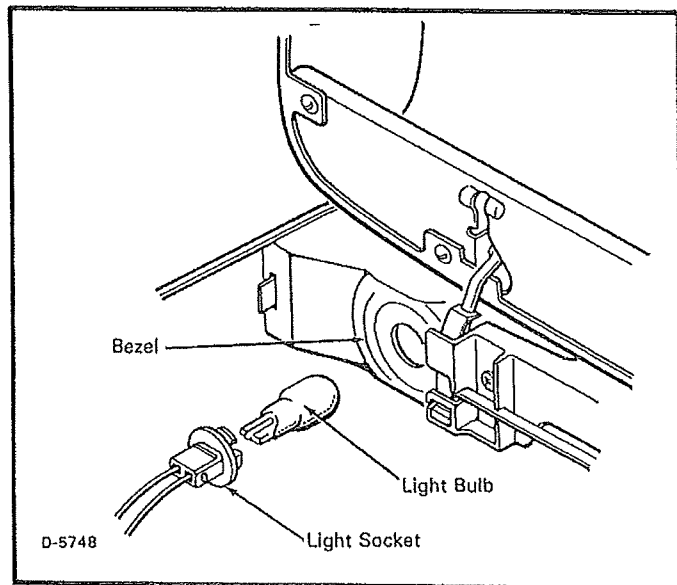

STORAGE

At the end of each year, prepare the unit for storage as follows.

THE ENGINE

1. Run the engine until the engine is warm.
2. Stop the engine.
3. Change the oil. See the engine manufacturer's instructions.
4. Clean the air filter. See the engine manufacturer's instructions.

THE FUEL SYSTEM



WARNING: Do not drain the gasoline inside a building or near a fire. Do not smoke because the fumes from the fuel can cause an explosion.

1. Start the engine.
2. Run the engine until the fuel tank and the carburetor are out of fuel and the engine stops.
3. Do not leave fuel in the fuel tank or the carburetor. The fuel can damage the function of the fuel system.

THE BATTERY

1. Completely charge the battery. See the instructions on "How To Prepare And Charge The Battery".
2. Disconnect both battery cables.
3. Clean the battery terminals of any deposits.
4. Do not remove the battery from the unit.

NOTE: After a long period of time in storage, the battery must be charged.

CLEAN THE UNIT

1. Clean the dirt and grass from the engine.
2. Clean the mower housing.
3. Wash the unit. Use wax to protect the unit.

LUBRICATE THE UNIT

See the "Lubrication" instructions in this book.

TROUBLE SHOOTING CHART

(Recoil-Start And Electric Models)

PROBLEM: The engine will not start.

1. Follow the steps, How To Start The Engine in this book.
2. Clean the battery terminals. Tighten the cables.
3. Check for a loose wire. Tighten the limit switches. (See the wiring diagram.)
4. Drain the fuel tank. Clean the fuel line. Replace the fuel filter.
5. Remove the spark plug(s). Move the throttle to the SLOW position. Turn the ignition key to the ON position. Try to start the engine several times. Install the spark plug.
6. Replace the spark plug.
7. Adjust the carburetor.

PROBLEM: The engine will not turn over.

1. Follow the steps, How To Start The Engine in this book.
2. Check the level of the acid in the battery. If needed, add water. Charge the battery.
3. Replace the fuse.
4. Check the wiring harness for damage or a loose connection. Repair the damaged wire.
5. Electric Models: replace the solenoid.
Recoil Models: replace the module.

PROBLEM: The engine is difficult to start.

1. Adjust the carburetor.
2. Replace the spark plug.
3. Replace the fuel filter.

PROBLEM: The engine does not run smooth or has a loss of power.

1. Check the oil.
2. Clean the air filter.
3. Clean the air screen.
4. Replace the spark plug.
5. The engine is working too hard. Use a lower gear.
6. Adjust the carburetor.
7. Replace the fuel filter.

PROBLEM: The engine does not run smooth at fast speed.

1. Replace the spark plug.
2. Adjust the throttle control.
3. Clean the air filter.
4. Replace the fuel filter.

PROBLEM: On slopes, the engine stops.

1. Mow up and down slopes. Never mow across a slope.
2. To activate the seat sensor, always sit in the middle of the seat.

PROBLEM: The engine will not idle.

1. Replace the spark plug.
2. Clean the air filter.
3. Adjust the carburetor.
4. Adjust the throttle control.
5. Drain the fuel tank. Clean the fuel line. Replace the fuel filter.

PROBLEM: A hot engine causes a decrease in power.

1. Clean the air screen.
2. Check the oil.
3. Adjust the carburetor.
4. Replace the fuel filter.

PROBLEM: Excessive vibration.

1. Replace the blade.
2. Check for loose engine bolts.
3. Decrease the air pressure in the tires. Correct air pressure on side of tire.
4. Adjust the carburetor.
5. Check for a damaged belt or damaged pulley. Replace the damaged parts.

PROBLEM: The grass does not discharge correctly.

1. Stop the engine. Clean the mower housing.
2. Raise the height of cut.
3. Replace or sharpen the blade(s).
4. Move the shift lever to a slower speed.
5. Move the throttle control to the FAST position.
6. Adjust the blade engagement control.
7. Replace the blade idler spring.

PROBLEM: The mower housing does not cut level.

1. Check the air pressure in the tires. Correct air pressure on side of tire.
2. Adjust the level of the mower housing.
3. Check the front axle. If the front axle does not freely pivot, loosen the two axle bolts.

PROBLEM: The unit will not move when the clutch is engaged.

1. Adjust the clutch.
2. Replace the motion drive belt.

PROBLEM: The rear wheels spin over uneven terrain.

1. Check the front axle. If the front axle does not freely pivot, loosen the two axle bolts.

PROBLEM: The unit moves slower or stops when the clutch is engaged.

1. Replace the motion drive belt.
2. Adjust the clutch.

