

For Husqvarna Parts Call 606-678-9623 or 606-561-4983

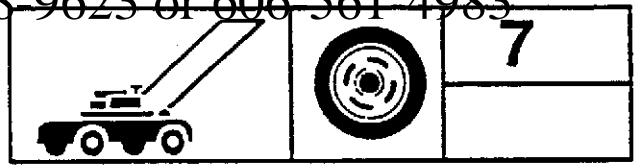

YT160

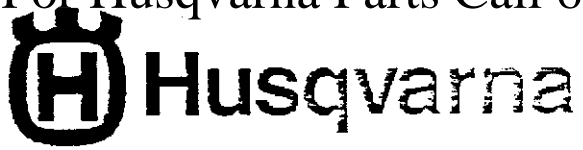
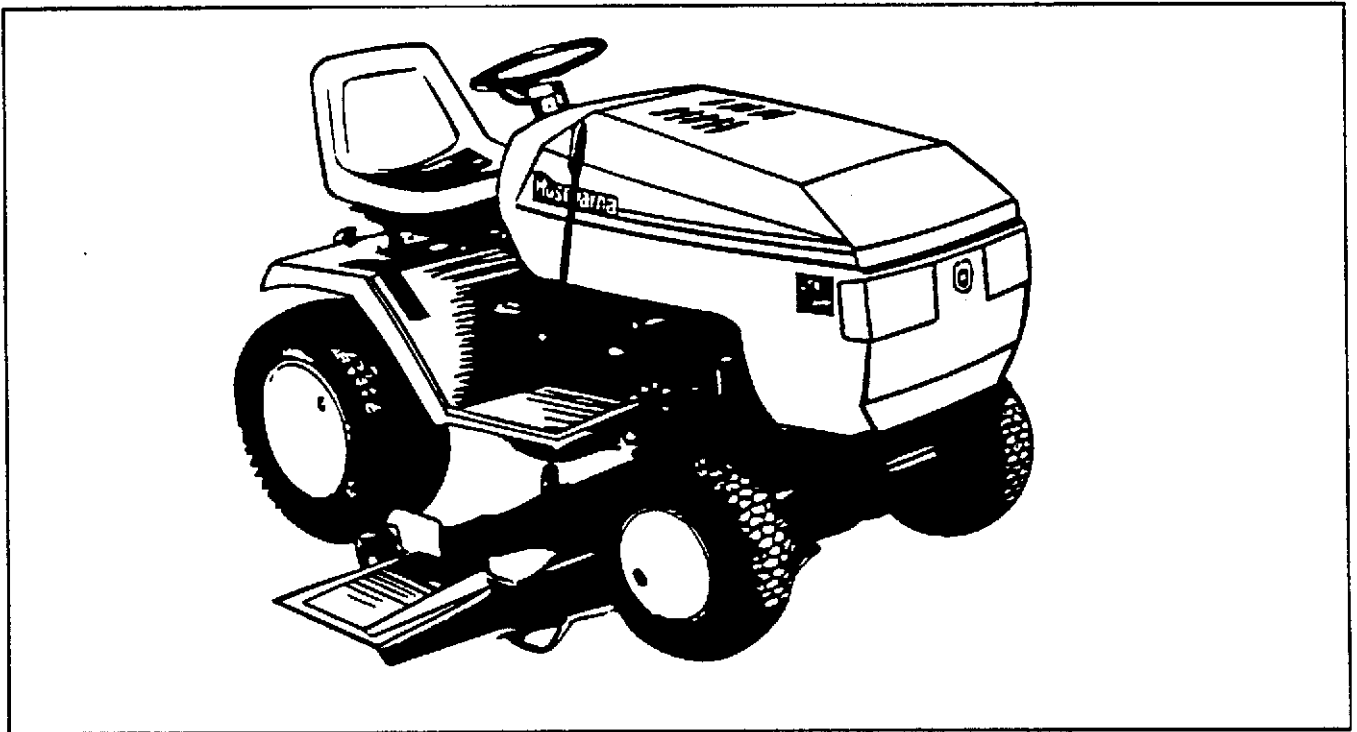

1.1993

Spare parts

Pièces détachées

HU1642A

531 03 02-16

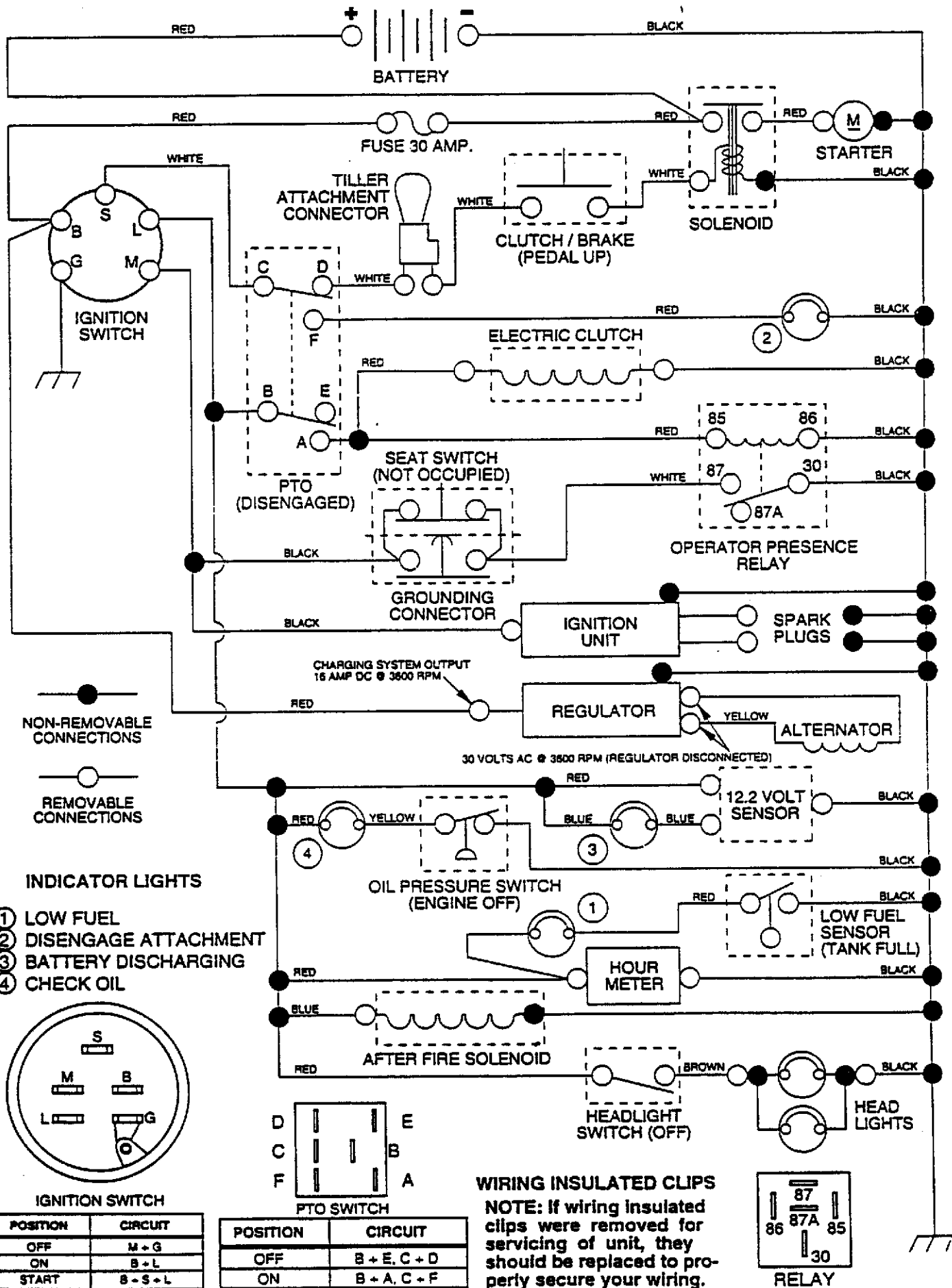

● NON-REMOVABLE CONNECTIONS
 ○ REMOVABLE CONNECTIONS

INDICATOR LIGHTS

- ① LOW FUEL
- ② DISENGAGE ATTACHMENT
- ③ BATTERY DISCHARGING
- ④ CHECK OIL

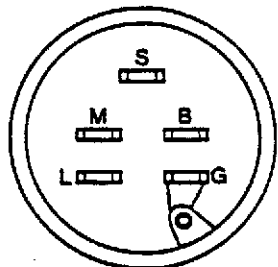

POSITION	CIRCUIT
OFF	M + G
ON	B + L
START	B - S + L

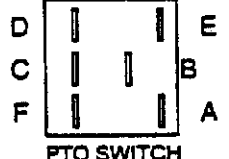

POSITION	CIRCUIT
OFF	B + E, C + D
ON	B + A, C + F

WIRING INSULATED CLIPS
 NOTE: If wiring insulated clips were removed for servicing of unit, they should be replaced to properly secure your wiring.

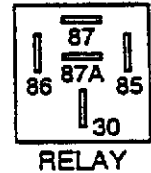

REPAIR PARTS

16 HP 42" TRACTOR - MODEL NO. YT160 (HU1642A), PRODUCT NO. 954 00 05-82

ELECTRICAL

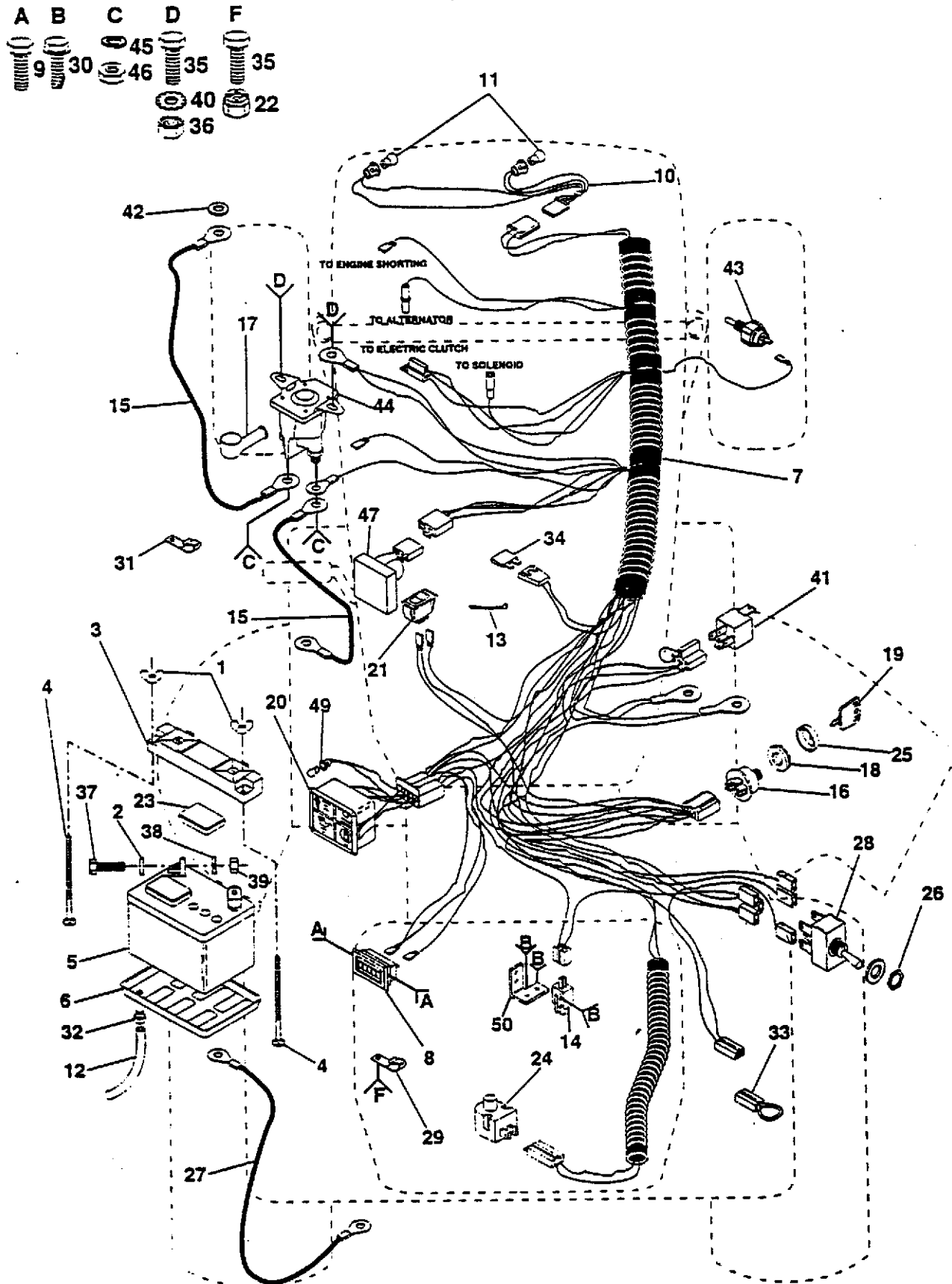

**16 HP 42" TRACTOR - MODEL NO. YT160 (HU1642A), PRODUCT NO. 954 00 05-82
 ELECTRICAL**

KEY NO.	PART NO.	DESCRIPTION
1	532123198	Nut, Wing 1/4-20
2	819091016	Washer 9/32 x 5/8 x 16 Gauge
3	532102476	Guard, Terminal
4	872240460	Bolt, Carriage 1/4-20 x 7-1/2
5	532121537	Battery
6	532124886	Tray, Battery
7	532139180	Harness, Ignition
8	532110940	Meter, Hour
9	817011008	Screw #10-24 x 1/2
10	532136849	Harness, Socket, Light (Includes Key #11)
11	532124893	Bulb, Light
12	532007697	Tube, Tray, Battery
13	532124756	Cable Tie
14	532104445	Switch, Clutch, Interlock
15	532124770	Cable, Battery (2)
16	532102972	Switch, Ignition
17	532131563	Cover, Terminal
18	532124211	Nut, Ignition
19	532122147	Key, Molded
20	532126519	Package, Light
21	532110712	Switch, Light
22	873680400	Nut, Crownlock 1/4-20
23	532121264	Caps, Battery
24	532121305	Switch, Plunger
25	532123620	Bezel, Ignition
26	532124932	Nut, Hex
27	532124773	Cable, Battery
28	532126018	Switch, P.T.O.
29	532124905	Clip, Insulated
30	817021008	Screw, Hex Tap #10-24 UNC
31	532124996	Clip, Fuel Line
32	532109596	Clamp, Hose
33	532102501	Loop, Wire
34	532108824	Fuse
35	874780408	Bolt, Hex 1/4-20 x 1/2 Grade 5
36	873510400	Nut, Hex, Keps 1/4-20
37	874760412	Bolt, Hex Head 1/4-20 x 3/4
38	810040400	Washer, Lock 1/4
39	873220400	Nut, Hex 1/4-20
40	811050400	Washer, Lock, External Tooth 1/4
41	532109748	Relay
42	811150400	Washer, Lock, Internal Tooth 1/4
43	532126825	Switch, Oil Sensor
44	532138406	Solenoid
45	810090400	Washer, Lock 1/4
46	873350400	Nut, Hex, Jam 1/4-20
47	532127385	Sensor, Low Voltage
48	819171216	Washer 17/32 x 3/4 x 16 Ga.
49	532110143	Bulb, Light Package
50	532108236	Bracket Switch Interlock

NOTE: All component dimensions given in U.S. inches.
 1 inch = 25.4 mm

**16 HP 42" TRACTOR - MODEL NO. YT160 (HU1642A), PRODUCT NO. 954 00 05-82
CHASSIS AND ENCLOSURES**

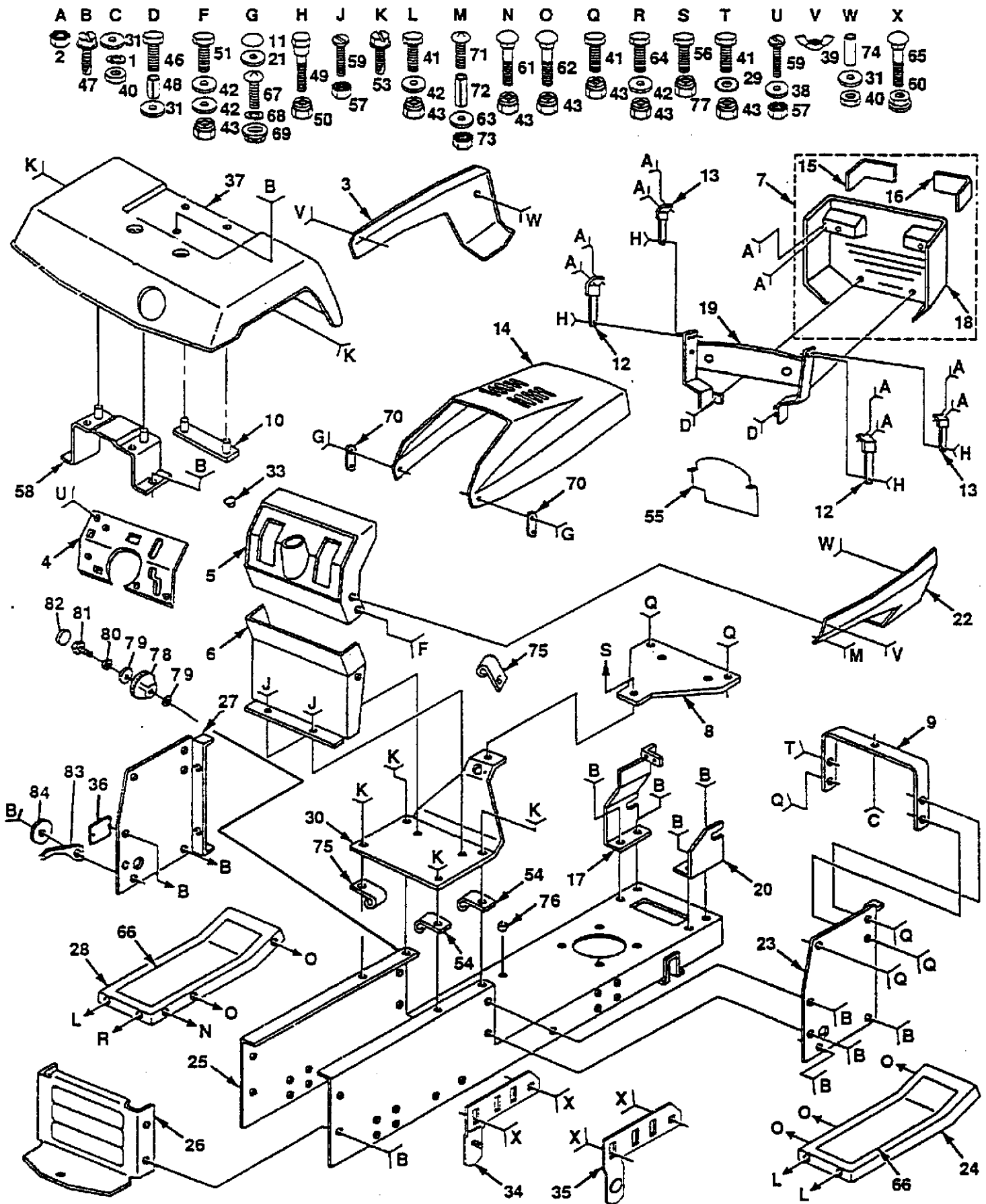

16 HP 42" TRACTOR - MODEL NO. YT160 (HU1642A), PRODUCT NO. 954 00 05-82 CHASSIS AND ENCLOSURES

KEY PART NO. NO.	DESCRIPTION	KEY PART NO. NO.	DESCRIPTION
1	810040400 Washer, Lock, Hvy Hlcl 1/4	46	874760440 Bolt, Hex 1/4-20 x 2-1/2
2	873510400 Nut, Hex, Keps 1/4-20 UNC	47	817490612 Screw, Thd., Roll. 3/8-16 x 3/4
3	532125389 Side Panel, LH	48	532121235 Spacer, Split
4	532138334 Plate, Dash	49	532123481 Bolt, Shoulder 1/4-20 UNC
5	532124182 Dashboard	50	873680400 Nut, Crownlock 1/4-20 UNC
6	532104805 Dash, Lower	51	874760620 Bolt, Hex, Fin. 3/8-16 UNC x 1-1/4
7	532127320 Grill Assembly	53	817490608 Screw, Thd., Roll. 3/8-16 x 1/2
8	532137654 Plate, Battery Support	54	532126471 Clip, Insulator
9	532124130 Support, Dash	55	532126493 Baffle, Vertical
10	532105511 Strap, Fender	56	874760512 Bolt, Hex, Fin. 5/16-18 UNC x 3/4
11	532110356 Cap, Black	57	873510500 Nut, Hex, Keps 5/16-18 UNC
12	532106784 Strap Assembly, Hinge, Rear	58	532137113 Bracket Fender
13	532104618 Strap Assembly, Hinge, Front	59	874180512 Screw, Machine 5/16-18 UNC x 3/4
14	532125007 Hood	60	873800600 Locknut, Hex, with Washer Insert 3/8-16 UNC
15	532124250 Lens, Headlight, LH, Smoked	61	872140608 Bolt, Carriage 3/8-16 UNC x 1
16	532124251 Lens, Headlight, RH, Smoked	62	872110606 Bolt, Carriage 3/8-16 x 3/4
17	532110853 Pivot Bracket Assembly, LH	63	819070818 Washer 7/32 x 1/2 x 18 Gauge
18	532127325 Grille	64	874760614 Bolt, Hex, Fin. 3/8-16 UNC x 7/8
19	532124574 Support Assembly, Grille	65	872140608 Bolt, Carriage 3/8-16 UNC x 1
20	532110852 Pivot Bracket Assembly, RH	66	532108256 Pad, Footrest
21	532110357 Washer, Cap	67	874191008 Screw, Machine, Cross Pan Head #10-24 x 1/2
22	532125390 Side Panel, RH	68	810071000 Washer, Lock #10
23	532136970 Dash Panel, RH	69	532125004 Nut, Weld
24	532124914 Footrest, RH	70	532109808 Latch, Chute
25	532135034 Chassis	71	874981020 Screw, Machine, Cross Pan Head #10-24 x 1-1/4
26	532137275 Drawbar	72	532007206 Spacer, Split #10 x 3/4
27	532136967 Dash Panel, LH	73	873731000 Nut, Hex, Keps #10-24 UNC
28	532124899 Footrest, LH	74	532001260 Spacer 17/64 x 1/2 x 3/8
29	811050600 Washer, Lock, Ext emal Tooth 3/8	75	532124996 Clip, Fuel Line
30	532138884 Saddle	76	532110436 Bushing, Snap Split
31	819091216 Washer 9/32 x 3/4 x 16 Gauge	77	873680500 Nut, Crownlock 5/16-18
33	532125085 Plug, Button	78	532123934 Scale Ind. Height
34	532134774 Pivot Bracket Assembly, Rear, LH	79	819112410 Washer 11/32 x 1-1/2 x 10 Ga.
35	532134775 Pivot Bracket Assembly, Rear, RH	80	810040500 Washer Lock Hvy Hlcl Spr. 5/16
36	532121794 Cover Access	81	874780516 Bolt Hex 5/16-18 x 1
37	532124929 Fender	82	532123935 Plug Hole
38	819111116 Washer 11/32 x 11/16 x 16 Gauge	83	532138346 Pointer Pnt Height Ind.
39	532123198 Wing Nut, Plastic 1/4-20	84	532120529 Washer Nylon
40	873220400 Nut, Hex, Fin. 1/4-20 UNC		
41	874760612 Bolt, Hex, Fin. 3/8-16 UNC x 3/4		
42	819131312 Washer 13/32 x 13/16 x 12 Gauge		
43	873680600 Nut, Crownlock 3/8-16 UNC		

NOTE: All component dimensions given in U.S. inches
1 inch = 25.4 mm

REPAIR PARTS

16 HP 42" TRACTOR - MODEL NO. YT160 (HU1642A), PRODUCT NO. 954 00 05-82
DRIVE

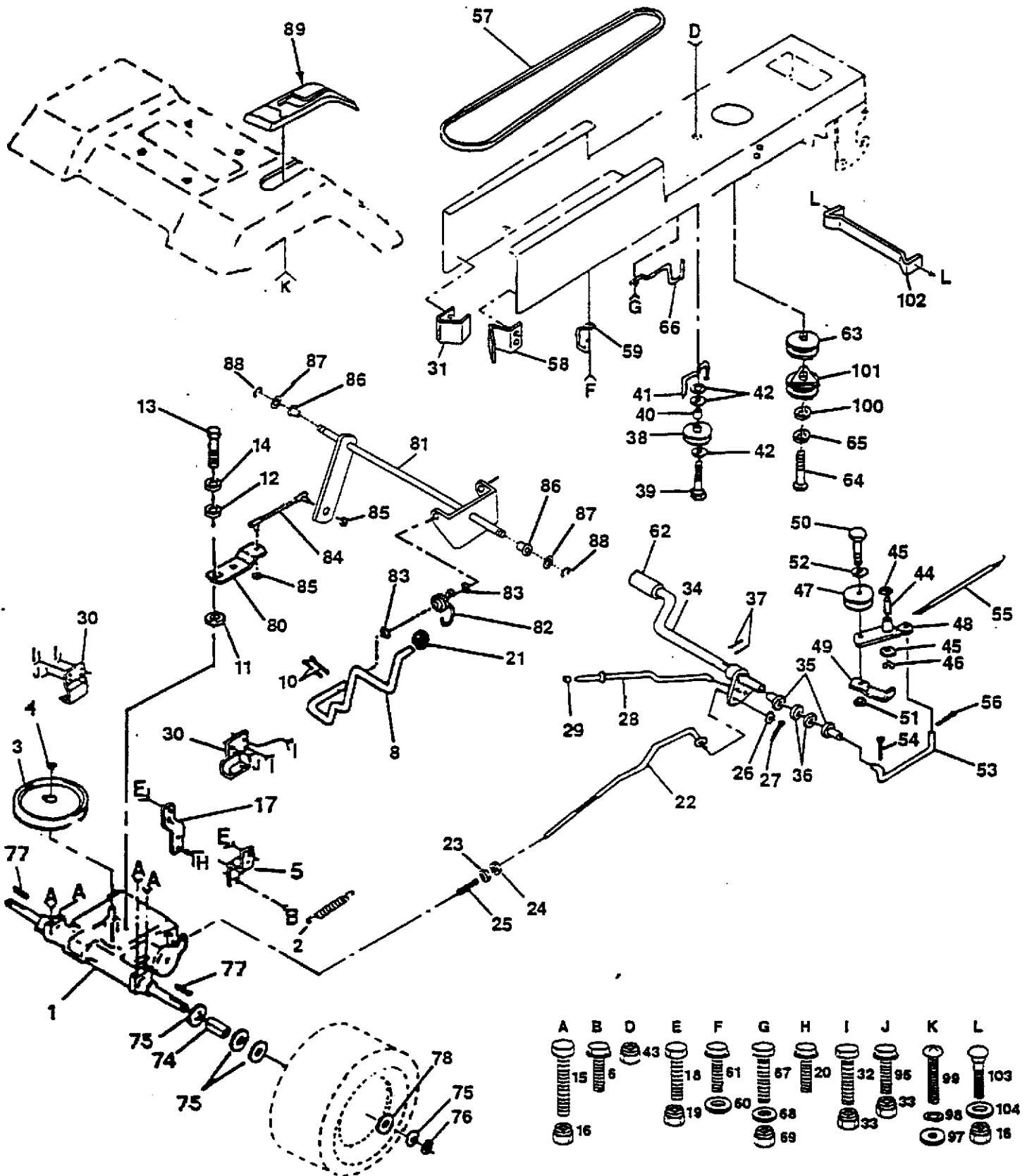

REPAIR PARTS

16 HP 42" TRACTOR - MODEL NO. YT160 (HU1642A), PRODUCT NO. 954 00 05-82

DRIVE

KEY PART NO. NO.	DESCRIPTION	KEY PART NO. NO.	DESCRIPTION
1	-----	50	874760624 Bolt Hex Hd 3/8-16unc X 1-1/2
2	532110422	51	873680600 Nut Crownlock 3/8-16 Unc
3	532123667	52	819131316 Washer 13/32 X 13/16 X 16 Ga
4	812000028	53	532105710 Link Clutch 7 66
5	532121520	54	876020412 Pin Cotter 1/8 X 3/4 Cad
6	817490512	55	532105709 Spring Return Clutch 6 75
8	532127288	56	876020412 Pin Cotter 1/8 X 3/4 Cad
10	876020416	57	532131006 V-Belt Ground Drive 95 25 42"
11	532105701	58	532127290 Keeper Belt RH LT Pnt/zinc 16g
12	819151216	59	532136715 Keeper Belt Chassis Span Ctr
13	871040412	60	819131312 Washer 13/32 X 13/16 X 12 Ga
14	810040400	61	817490612 Screw Thdrol 3/8-16x3/4 Ty-tt
15	874760540	62	532123533 Cover Pedal Premuim
16	873680500	63	532136905 Engine Pulley LT/YT
17	532121520	64	871170768 Bolt, Hex 7/16-20 x 4-1/4
18	874760612	65	810040700 Washer Lock Hvy Hlcl Spr 7/16
19	873680600	66	532129921 Keeper Belt Engine LH LT
20	817490512	67	874760616 Bolt Fin Hex 3/8-16unc X 1
21	532121274	68	819131312 Washer 13/32 X 13/16 X 12 Ga
22	532130804	69	873680600 Nut Crownlock 3/8-16 Unc
23	873800600	74	532109502 Spacer Split
24	873350600	75	532121749 Washer 25/32 X 1 1/4 X 16 Ga
25	532106888	76	812000001 E-ring #5133-75
26	819131316	77	532123583 Key Square 2 0 X 1845/ 1865
27	876020412	78	532121748 Washer 25/32 X 1-5/8 X 16 Ga
28	532133261	80	532131487 Arm Shift Transaxle
29	532071673	81	532136933 Shaft Asm Cross 20"t 42"deck
30	532130807	82	532123782 Spring Torsion T/a
31	532127289	83	819171216 Washer 17/32 X 3/4 X 16 Ga
32	874760512	84	532132183 Rod Tie Shift Adj Ball
33	873680500	85	873530400 Nut Nylock 1/4-28
34	532122424	86	532071208 Bushing Rod Strg 629/632 Id
35	532120183	87	819212016 Washer 21/32 X 1-1/4 X 16 Ga
36	819211616	88	812000008 Ring Klip #5304-62
37	532124963	89	532127287 Console Shift 6sp W/ign LT
38	532123674	95	817490612 Screw Thdrol 3/8-16 x 3/4
39	874760644	97	819060718 Washer 3/16 X 7/16 X 18 Ga
40	532124965	98	810100800 Washer Lock #8
41	532109070	99	874640808 Screw #8x1/2
42	819131312	100	532126197 Washer
43	873680600	101	532137140 1-1/2 OD X 15/32 ID X .250
44	532105706	102	532137141 Clutch Electric
45	532110812	103	872140506 Bracket Asm. Clutch
46	812000039	104	819111012 Bolt, Carriage 5/16-18 x 3/4
47	532127783		Washer 11/32 x 5/8 x 12 Ga.
48	532123789		
49	532123205		

NOTE: All component dimensions given in U.S. inches
1 inch = 25.4 mm

REPAIR PARTS

16 HP 42" TRACTOR - MODEL NO. YT160 (HU1642A), PRODUCT NO. 954 00 05-82
STEERING ASSEMBLY

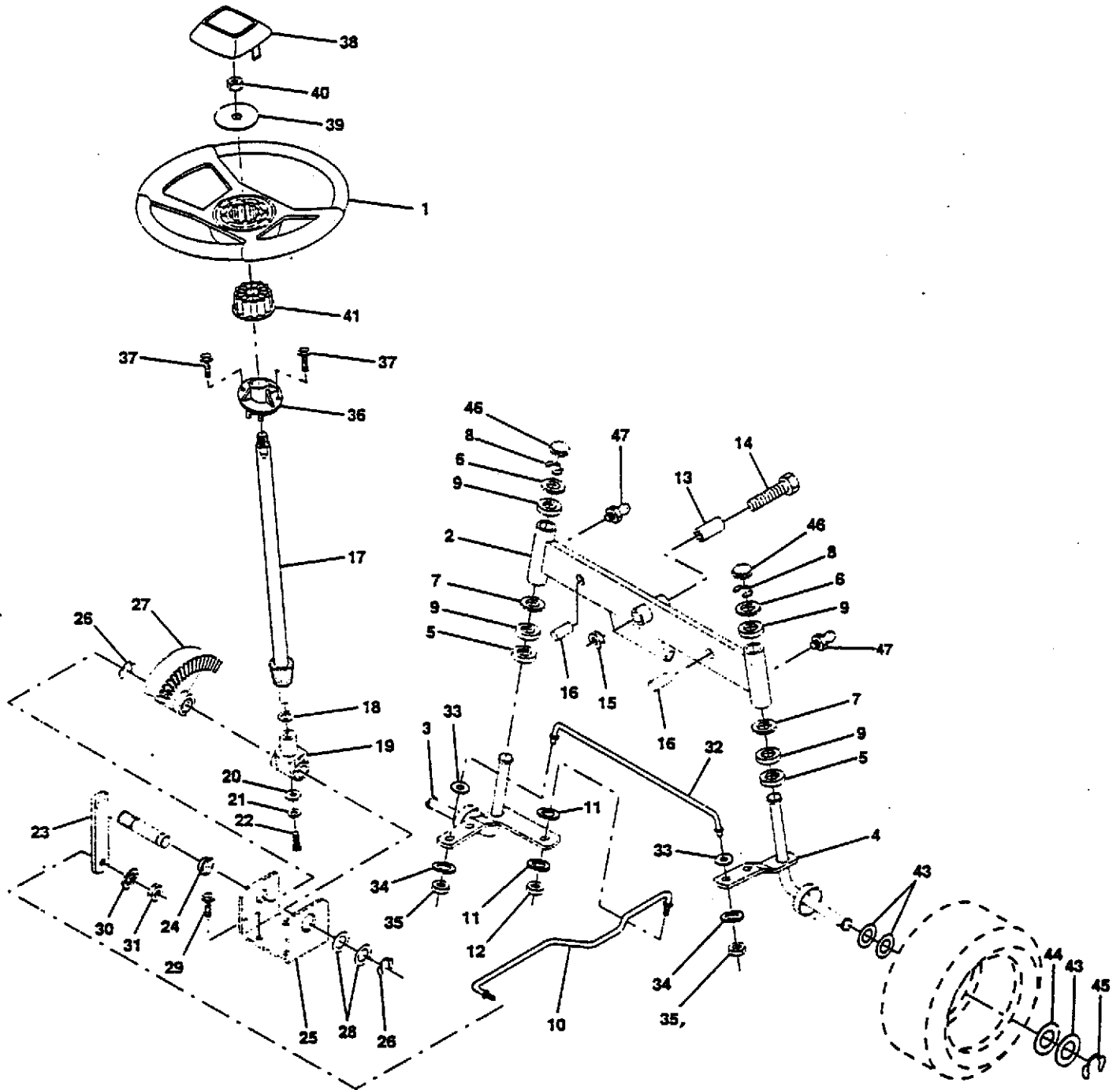

16 HP 42" TRACTOR - MODEL NO. YT160 (HU1642A), PRODUCT NO. 954 00 05-82
STEERING ASSEMBLY

KEY PART NO.	PART NO.	DESCRIPTION
1	532124415	Wheel Steering Auto Grey
2	532133988	Axle Asm Fr LT W/gzks 38/42
3	532135227	Spindle Asm LH
4	532135228	Spindle Asm RH
5	532124931	Bearing Race Thrust Harden
6	532121748	Washer 25/32 X 1-5/8 X 16 Ga
7	819272016	Washer 27/32 X 1-1/4 X 16 Ga
8	812000029	Ring Klip #t5304-75
9	532124937	Bearing Col Strg Blk
10	532130468	Link Drag Sol Ball Jt 20 064
11	810040600	Washer Lock Hvy Hlcl Spr 3/8
12	873610600	Nut Fin Hex 3/8-24 Unf
13	532110438	Spacer Bearing Axle Front
14	874011056	Bolt Hex 5/8-11 Unc X 3-1/2
15	873901000	Nut Lock Flange 5/8-11 Unc
16	532132624	Pin Axle 5/8 X 1 55/1 54 Lg
17	532128762	Shaft Asm Strg 20 31 x 3/4 YP YT
18	532057079	Washer Thrust 515x 750x 033
19	532124035	Support Shaft
20	532126684	Washer Shim 1/4 X 5/8 X 062
21	810040400	Washer Lock Hvy Helical 1/4
22	871070410	Screw Hex Socket 1/4-20 X 5/8
23	532127501	Shaft Asm Pittman
24	532109816	Nyliner Snap In
25	532124036	Bracket Steering
26	812000029	Ring Klip #t5304-75
27	532136874	Gear Sector
28	532124931	Bearing Race Thrust Harden
29	817490612	Screw Thdrol 3/8-16x3/4 Ty-tt
30	810040600	Washer Lock Hvy Hlcl Spr 3/8
31	873610600	Nut Fin Hex 3/8-24 Unf
32	532130467	Rod Tie Wire Form 19 75 Elec
33	819111216	Washer 11/32 x 3/4 x 16 Ga.
34	810040500	Washer, Lock Hvy Hlcl Spr 5/16
35	873810500	Locknut 5/16-24 Unf
36	532124720	Bushing Strg Blk 742/747 Id
37	817431008	Screw Slftp #10-16 X 1/2 Ty-b
38	532124416	Insert Cap Strg Wh Aut Hus Gry
39	532100712	Washer 53 X 2 25 X 160 Zinc
40	873940800	Nut Hex Jam Toplock 1/2-20 Unf
41	532100711	Adapter Wheel Strg 758/ 753id
43	532121749	Washer 25/32 X 1 1/4 X 16 Ga
44	532121748	Washer 25/32 X 1-5/8 X 16 Ga
45	812000029	Ring Klip #t5304-75
46	532121232	Cap Spindle Fr Top Blk
47	532124836	Fitting Grease

NOTE: All component dimensions given in U.S. inches
 1 inch = 25.4 mm

REPAIR PARTS
16 HP 42" TRACTOR - MODEL NO. YT160 (HU1642A), PRODUCT NO. 954 00 05-82
SEAT ASSEMBLY

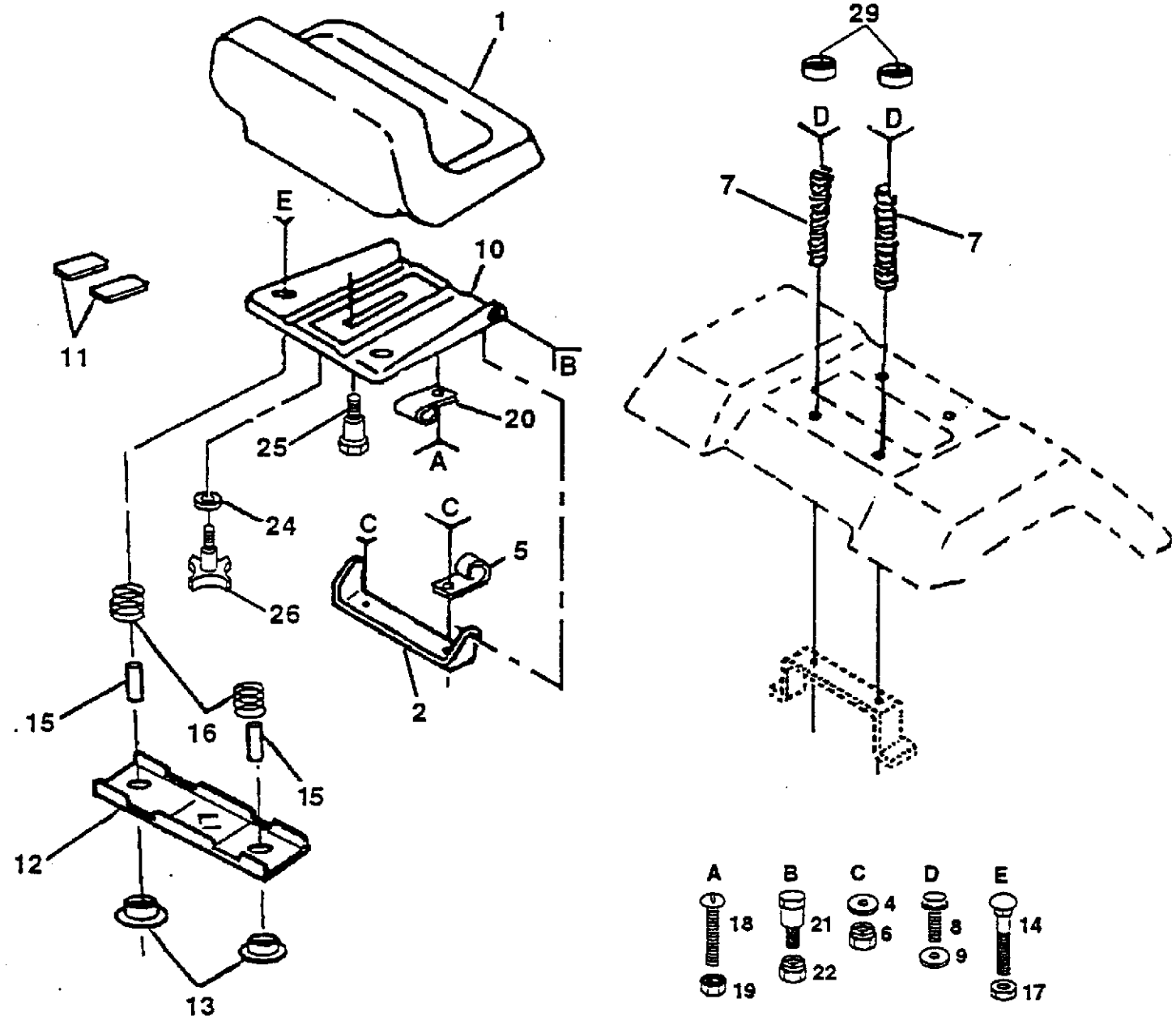

KEY PART NO. NO.	DESCRIPTION
1 532124186	Seat V-550 Gry/blk Std
2 532126656	Bracket Pivot Seat 8 720
4 819131210	Washer 13/32 X 3/4 X 10 Ga
5 532124996	Clip Line Fuel 13/32 Mtg Hole
6 873680600	Nut Crownlock 3/8-16 Unc
7 532124181	Spring Seat Cprsn 2 250 Blk Zi
8 817490508	Screw Hwsh Thdrol 5/16-18 x 1/2
9 819131614	Washer 13/32 X 1 X 14 Ga
10 532131451	Pan Seat
11 532121251	Strip Foam Gray Or Black
12 532121246	Bracket Mounting Switch
13 532121248	Bushing Snap Blk Nyl 50 Id
14 872050411	Bolt Rdhd Sht Nk 1/4-20x1-3/8
15 532121249	Spacer Split 28x 88 Yel Zinc

KEY PART NO. NO.	DESCRIPTION
16 532123740	Spring Cprsn 1 310 Blk Pnt
17 532123976	Nut Lock 1/4 Lge Fig Gr 5 Zinc
18 874641008	Screw SLTD Pan Hd #10-32 X 1/2
19 873951000	Nut Keps #10-32 Unf
20 532124967	Clip Insulated 11/32 Mtg Hole
21 532105529	Bolt Shoulder 5/16-18 Unc Blkz
22 873680500	Nut Crown Lock 5/16-18
24 819171912	Washer 17/32 X 1-3/16 X 12 Ga
25 532127018	Bolt Shoulder 5/16-18 X 62
26 532120068	Knob Seat 1/2-13unc Blk
29 532124238	Cap Spring Seat

NOTE: All component dimensions given in U.S. inches
 1 inch = 25.4 mm

REPAIR PARTS

16 HP 42" TRACTOR - MODEL NO. YT160 (HU1642A), PRODUCT NO. 954 00 05-82

DECALS

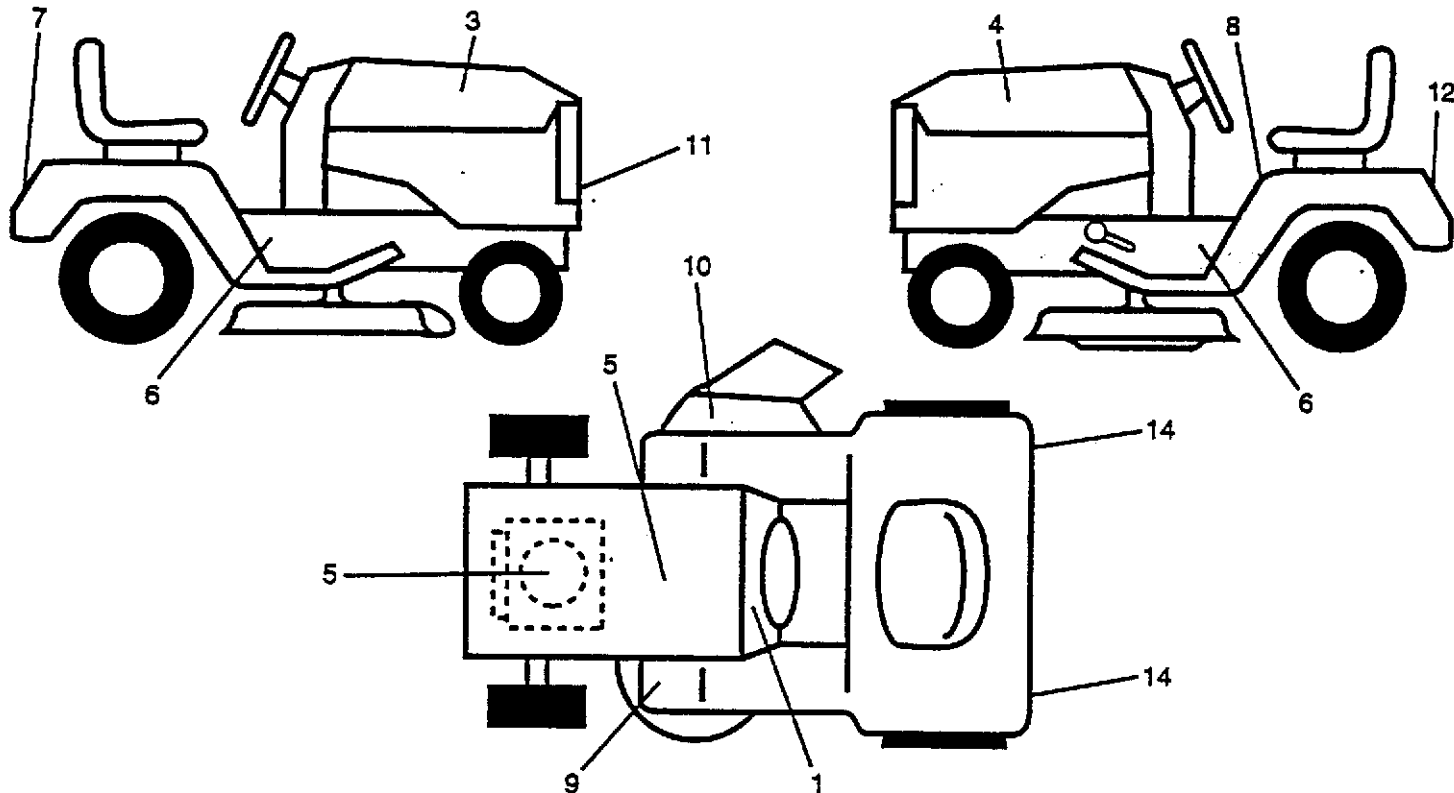

KEY PART NO. NO.

KEY PART NO.	NO.	DESCRIPTION
1	532136795	Decal Instruction Dash Eng/fr
2	532131973	Decal HP Engine
3	532139772	Decal Hood RH Husq YT160
4	532139773	Decal Hood LH Husq YT160
5	532121549	Decal Caution Battery Fr/ger
6	532131589	Decal Chassis
7	532131582	Decal Fender Husqvarna
8	532133795	Decal Caution Fender Eng/fr
9	532101892	Decal Clutch/brake Eng/fr
10	532137259	Decal Warning MULT-LANGUAGE
11	532125989	Decal Grille Husqvarna

KEY PART NO. NO.

KEY PART NO.	NO.	DESCRIPTION
12	532127520	Decal USA White
14	532106202	Reflector Tail Light Red/amber
-	532138311	Decal Lift Handle(Lift Handle)
-	532139122	Manual Owners, English
-	532139121	Manual Owners, French

Available accessories not included with tractor:

- BD20 42" Snow blade
- LC05 33 lb. Weights (pairs)
- SB20 40" Snow Thrower
- CE42 42" Bagger
- TL21 21" P.T.O. Tiller
- MK420 42" Mulcher Kit

WHEELS & TIRES

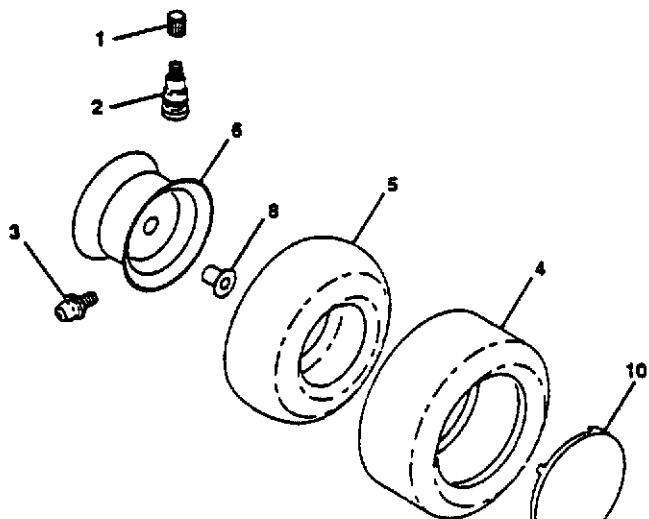

KEY PART NO. NO.

KEY PART NO.	NO.	DESCRIPTION
1	532059192	Cap Valve Tire
2	532065139	Stem Valve
3	532124957	Fitting Grease (Front Wheel Only)
4	532106222	Tire F Ts 15 X 6 0 - 6 Service
	532138468	Tire R Ts 20 8-8 C Service
5	532059904	Tube Front (Service Item Only)
	532124926	Tube Rear (Service Item Only)
6	532124999	Rim Asm 8"rear White Service
	532125102	Rim Asm 6" front White Service
8	532124959	Bearing Flange (Front Wheel Only)
10	532124577	Cover Wheel 6"white
	532124578	Cover Wheel 8"white

NOTE: All component dimensions given in U.S. inches
1 inch = 25.4 mm

REPAIR PARTS

16 HP 42" TRACTOR - MODEL NO. YT160 (HU1642A), PRODUCT NO. 954 00 05-82
ENGINE

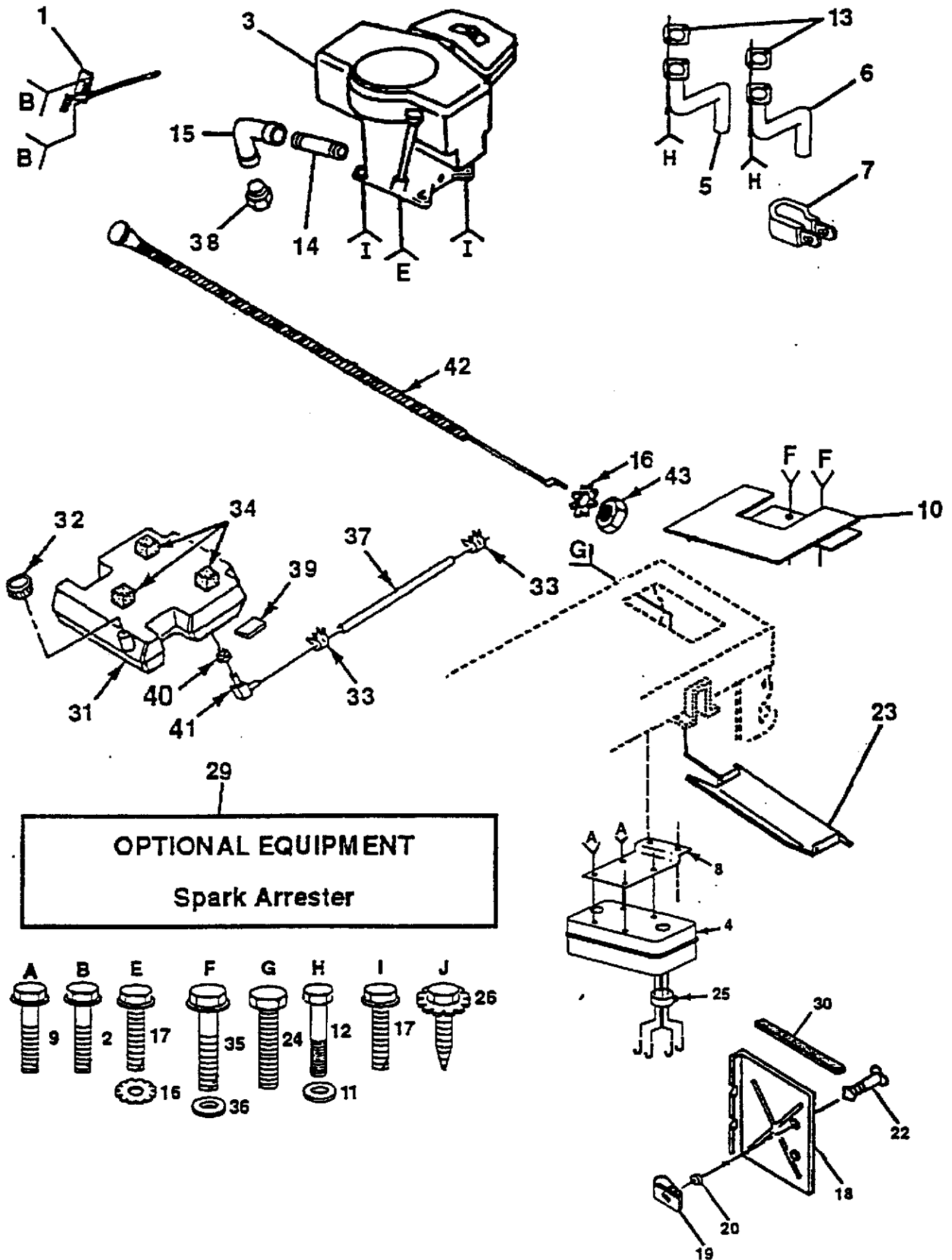

**16 HP 42" TRACTOR - MODEL NO. YT160 (HU1642A), PRODUCT NO. 954 00 05-82
 ENGINE**

KEY PART NO.	NO.	DESCRIPTION
1	532132748	Control RH Blk Fig 44 75
2	817720410	Screw Hex Thd Cut 1/4-20x5/8 T
3	-----	Engine B&S, Model No. 303777
4	532122440	Muffler LT B&S
5	532122434	Tube Manifold LH
6	532122435	Tube Manifold RH
7	532138129	Clamp Tube Double Engine
8	532122439	Bracket Muffler Mounting
9	817190408	Screw Hex Wsh Thd Cut 1/4-20
10	532128199	Shield Heat LT
11	-----	Washer Lock Hvy Hlcl 1/4 (Order from Engine Manufacturer)
12	-----	Bolt, Fin Hex 1/4-20 x 3/4 (Order from Engine Manufacturer)
13	-----	Muffler Gasket (Order from Engine Manufacturer)
14	813280336	Nipple Pipe 3/8 Npt X 4-1/2"
15	813200300	Elbow Std 90 Degree 3/8-18 Npt
16	811050600	Washer Lock Ext Tooth 3/8
17	817490620	Screw Thdrol 3/8-16 x 1-1/4
18	532133746	Shield Heat Electric
19	532105839	Receptacle 1/4 Turn
20	532105838	Retainer 1/4 Turn
22	532123650	Stud 1/4 Turn
23	532128953	Shield Heat Browning LT/YT
24	817021008	Screw Tap Hex #10-24unc X 1/2
25	532101326	Deflector Muffler
26	817030808	Screw Spiderloc Hex Hd #8 x 1/2
29	532137180	Kit Spark Arrestor (Flat Scm)
30	532105037	Foam Strip 18"
31	532127383	Tank Fuel 3 50 Rear
32	532123549	Cap Asm Fuel W/sym Vented
33	532123487	Clamp Hose Blk
34	532106082	Pad, Spacer
35	817490512	Screw Thdrol 5/16-18 x 3/4
36	819132012	Washer 13/32 x 1-1/4 x 12 Ga.
37	532008543	Line Fuel 54"
38	-----	Plug Oil Drain (Order From Engine Manufacturer)
39	532109277	Pad, Idler
40	532124952	Bushing
41	532139277	Stem Tank Fuel
42	532132781	Choke Control
43	873610600	Nut, Fin Hex 3/8-24 Unf

NOTE: All component dimensions given in U.S. inches.
 1 inch = 25.4 mm

REPAIR PARTS

16 HP 42" TRACTOR - MODEL NO. YT160 (HU1642A), PRODUCT NO. 954 00 05-82
MOWER LIFT ASSEMBLY

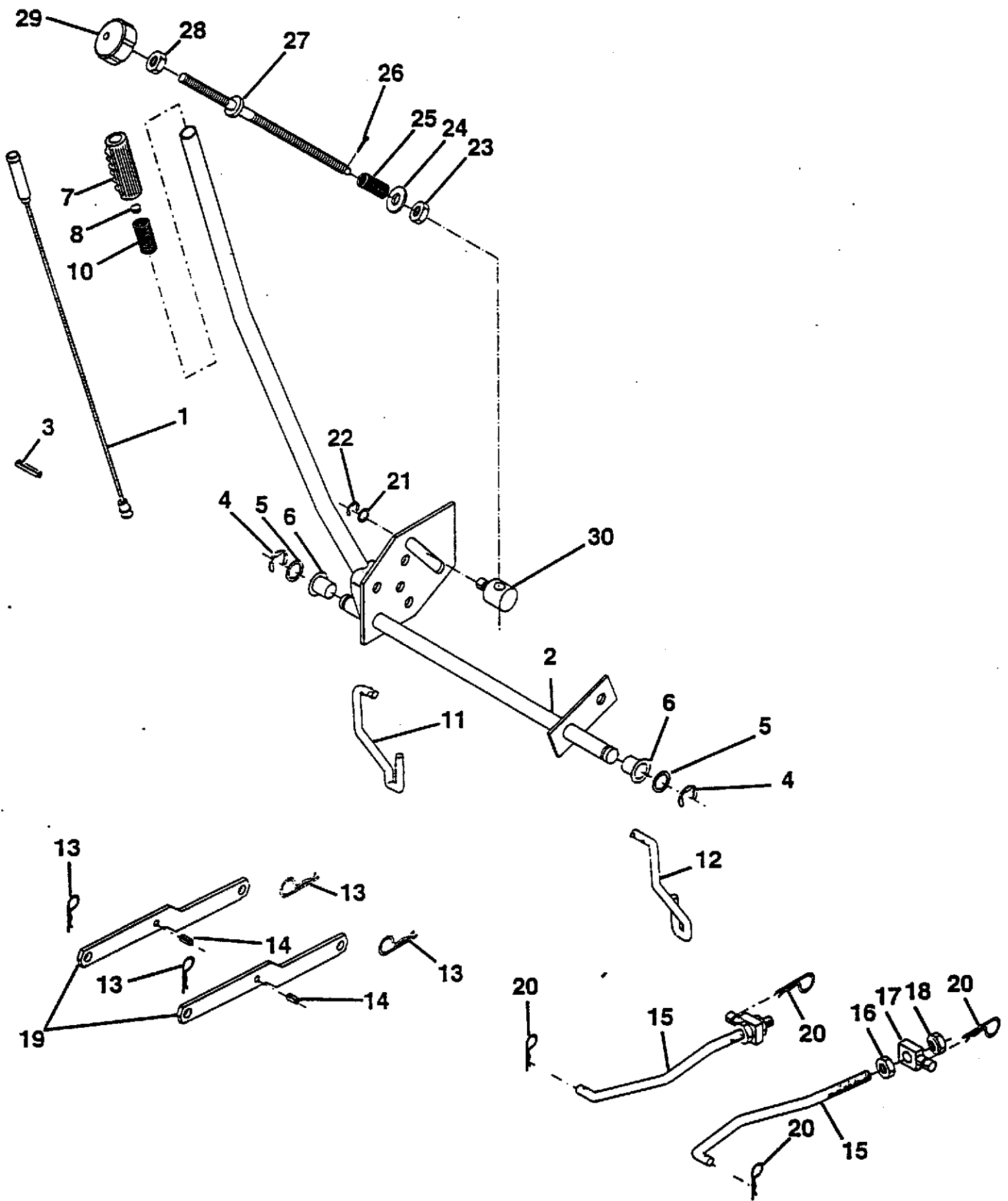

For Husqvarna Parts Call 606-678-9623 or 606-561-4983
REPAIR PARTS
16 HP 42" TRACTOR - MODEL NO. YT160 (HU1642A), PRODUCT NO. 954 00 05-82
MOWER LIFT ASSEMBLY

KEY PART NO.	NO.	DESCRIPTION
1	532136971	Wire Asm Inner W/plunger 20 56
2	532136969	Shaft Asm Lift RH w/Inf W/T
3	532138284	Pin Groove 1 500 Zinc
4	812000002	E Ring #5133-62
5	819211416	Washer 21/32 X 7/8 X 16 Ga
6	532120183	Bearing Nylon Blk 629 Id
7	532125631	Grip Handle Fluted Blk
8	532124526	Button Plunger Black
10	532122512	Spring Cprsn 3 750 Oiled
11	532134619	Link Lift LH Fixed Length
12	532135388	Link Lift RH Fixed Length
13	532124670	Retainer Spring
14	532135563	Pin Roll SLT 5/16 X 1 25 Blk O
15	532127218	Link Front
16	873350800	Nut Jam Hex 1/2-13 Unc
17	532130171	Trunnion Blk Zinc
18	873800800	Nut Lock W/wsh 1/2-13unc
19	532130832	Arm Suspension Rear
20	532124660	Retainer Spring
21	819151216	Washer 15/32 X 3/4 X 16 Ga
22	812000037	Ring Klip #t5304-37
23	532110807	Nut Special
24	819131016	Washer 13/32 X 5/8 X 16 Ga
25	532124874	Spring 2-1/8"
26	876020308	Pin Cotter 3/32 X 1/2
27	532110729	Rod Adj Lift Zinc 9 00 Wrk Lg
28	873350600	Nut Hex Jam 3/8-16 Unc
29	532138057	Knob Inf 3/8-16 Unc Blk W/sym
30	532110810	Trunnion Dp Stop Dbl Thds PLT

NOTE: All component dimensions given in U.S. inches
1 inch = 25.4 mm

For Husqvarna Parts Call 606-678-9623 or 606-561-4983

REPAIR PARTS

16 HP 42" TRACTOR - MODEL NO. YT160 (HU1642A), PRODUCT NO. 954 00 05-82

42" MOWER

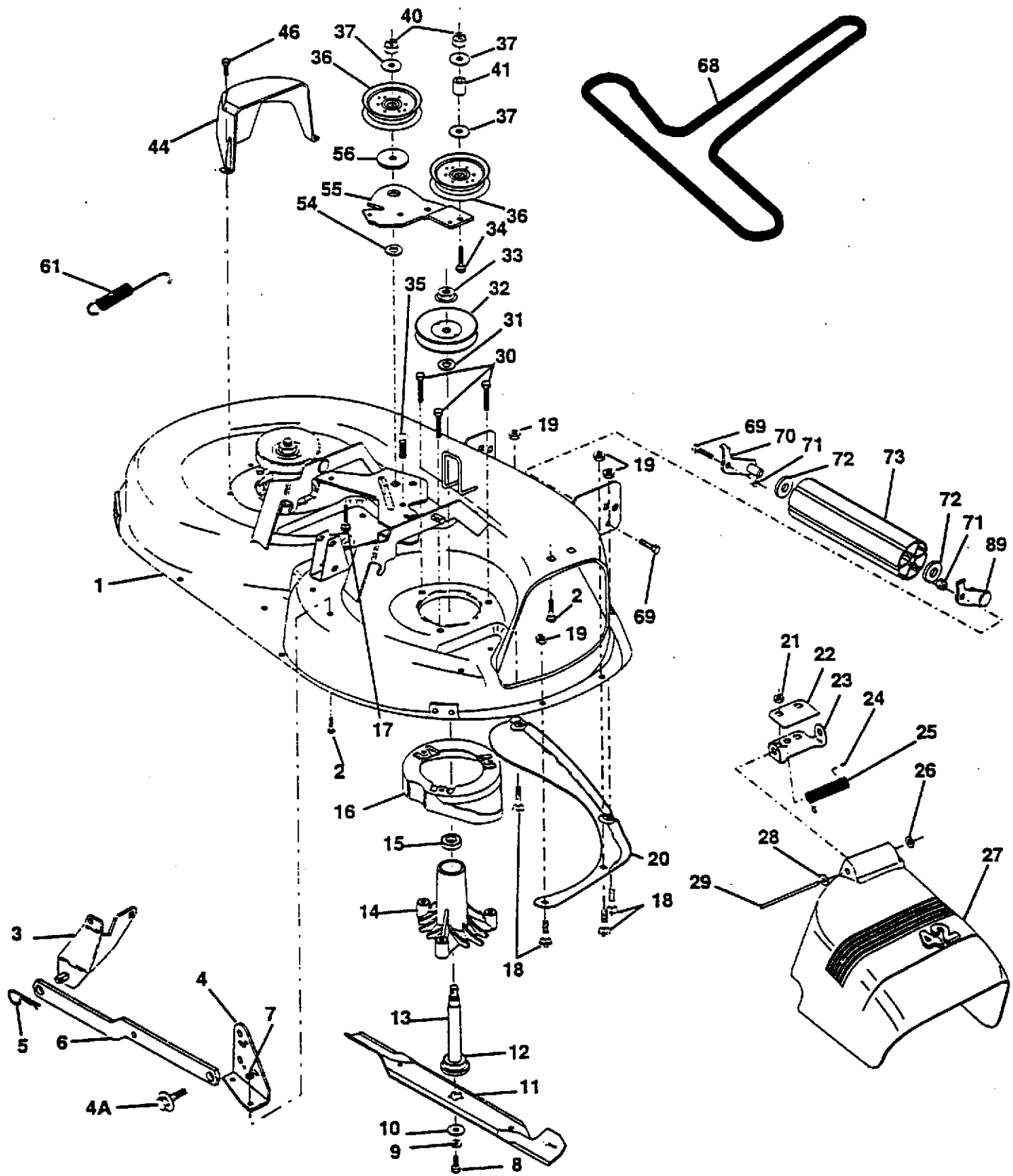

REPAIR PARTS

**16 HP 42" TRACTOR - MODEL NO. YT160 (HU1642A), PRODUCT NO. 954 00 05-82
42" MOWER**

KEY PART NO.	NO.	DESCRIPTION
1	532138024	Deck Asm MWR 42"weldment
2	872140506	Bolt Rdhd Sqnk 5/16-18unc X3/4
3	532138017	Bracket Asm Fr Sway Bar 38/42
4	532138440	Bracket Asm Deck 42"sway Bar
4A	532132827	Bolt Shoulder
5	532124670	Retainer Spring
6	532130832	Arm Suspension Rear
7	873800500	Locknut-hex W/ins 5/16-18unc P
8	532850857	Bolt 3/8-24x1 25 Gr8 Patched
9	810030600	Washer Lock Hvy 3/8 Unplated
10	532129962	Washer Hard Blade Mower Vented
11	532138498	Blade Mower High Perf 42"
12	532129895	Bearing Ball #6204 (Mandrel)
13	532137645	Shaft Asm W/lower Bearing
14	532128774	Housing Mandrel Vented(machd)
15	532110485	Bearing Ball Mandrel
16	532136929	Stripper Mower Vented
17	872110616	Bolt Rdhd Sqnk 3/8-16 X 2
18	872140505	Bolt Carr 5/16-18 X 5/8
19	873800500	Locknut-hex W/ins 5/16-18unc P
20	532136888	Baffle Vortex 42
21	873680500	Nut Crown Lock 5/16-18
22	532134753	Stiffener Bracket 42"deck
23	532131267	Bracket Deflector Mower 42"
24	532105304	Cap Sleeve 80x 112 Blk Mower
25	532123713	Spring Torsion Deflector 2 52
26	532110452	Nut Push Phos & Oil
27	532130968	Shield Deflector Mower 42" Blk
28	819111016	Washer 11/32 X 5/8 X 16 Ga
29	532131491	Rod Hinge 42"6 75 Wlg
30	532078158	Bolt 5/16-18 X 1 25 T/t
31	532129963	Washer Spacer Mower Vented
32	532129861	Pulley Mandrel 42"
33	532137266	Nut 9/16top Lock Fing Cntr
34	872110622	Bolt Rdhd 3/8-16uncx2-3/4 Gr5
35	532133835	Fastner Christmas Tree
36	532131494	Pulley Idler Flat 3 060
37	819131316	Washer 13/32 X 13/16 X 16 Ga
40	873680600	Nut Crownlock 3/8-16 Unc
41	532132823	Spacer Spring Stop Idler
44	532134236	Guard Mandrel LH Black
46	532137729	Screw Thdrol 1/4-20x5/8
54	532133943	Washer Hardened
55	532133844	Arm Idler 42"mower LT/YT
56	532122052	Spacer Retainer Pm Mower
61	532131950	Spring Ext. Elect
68	532130969	V-Belt Mower 42" 92 40
69	874760616	Bolt Fin Hex 3/8-16unc X 1
70	532132274	Bracket Asm Noseroller LH
71	873680600	Nut Crownlock 3/8-16 Unc
72	819171416	Washer 17/32 X 7/8 X 16 Ga
73	532132264	Roller Nose 38 & 42
89	532132273	Bracket Asm Noseroller RH
--	532138506	Deck Serv 42" Elec Vent (Standard Deck - Order Nose Roller components separately Key Nos. 69-73 and 89)
--	532130794	Mandrel Assembly (Includes Key Numbers 8-10, 12-15, 31 and 33)

NOTE: All component dimensions given in U.S. inches
1 inch = 25.4 mm

For Husqvarna Parts Call 606-678-9623 or 606-561-4983
REPAIR PARTS
 16 HP 42" TRACTOR - MODEL NO. YT160 (HU1642A), PRODUCT NO. 954 00 05-82
 DANA TRANSAXLE - - MODEL NUMBER 4360-52

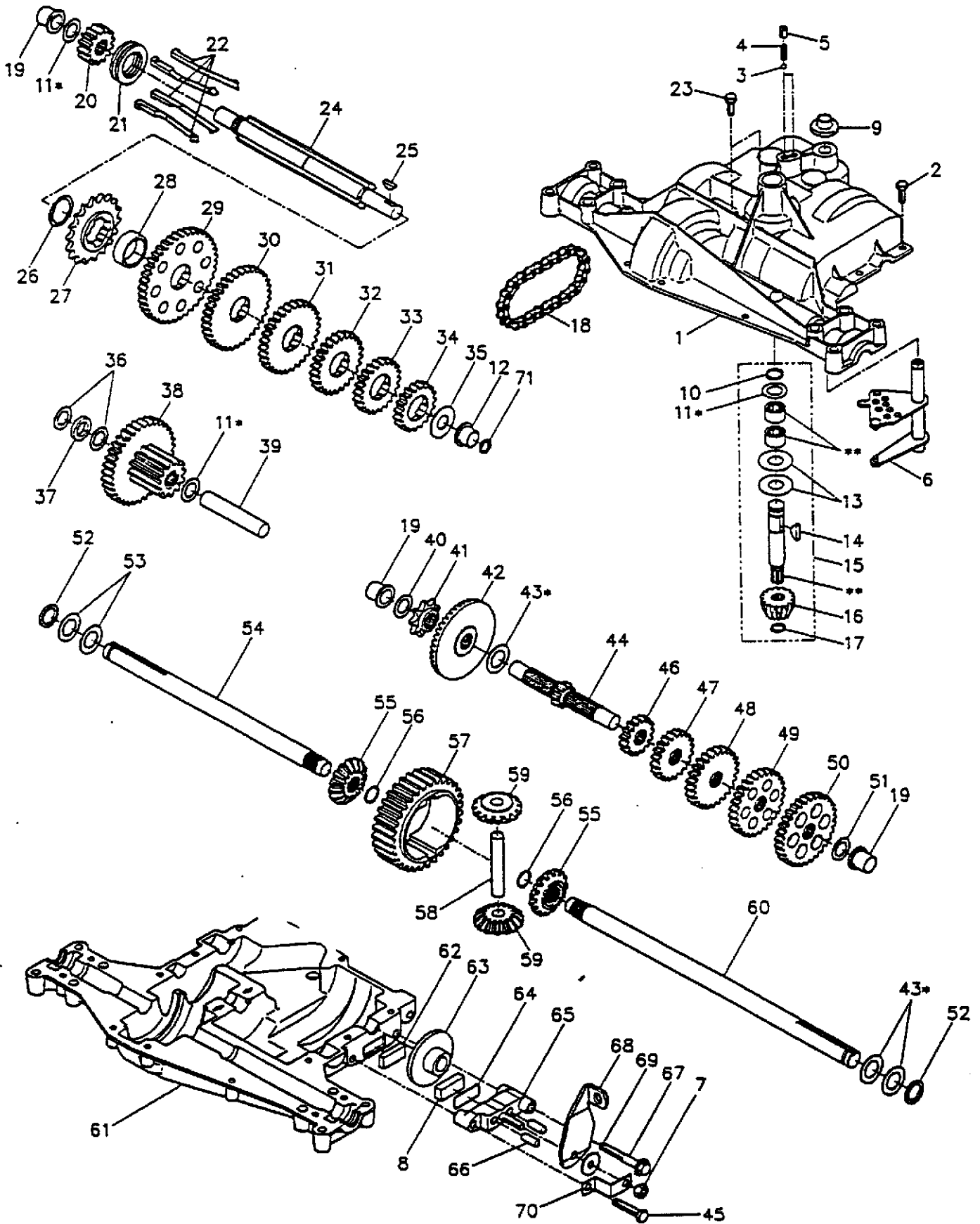

16 HP 42" TRACTOR - MODEL NO. YT160 (HU1642A), PRODUCT NO. 954 00 05-82

DANA TRANSAXLE - - MODEL NUMBER 4360-52

KEY PART NO. NO.	DESCRIPTION	KEY PART NO. NO.	DESCRIPTION
1	532138248 Housing, Upper	40	532003422 Washer, Plain .631 x 1.00 x .015
2	532002274 Screw, Self-Tapping, Large 1/4-20 x .734	41	532105928 Sprocket, 9 Teeth
3	532134400 Ball, Detent	42	532106605 Gear, Bevel, 42 Teeth
4	532105904 Spring, Detent	43	532134394 * Assembly, Kit, Shim .750 Shaft
5	532105905 Screw, Set	44	532124640 Shaft, Drive
6	532134788 Kit, Shifter Assembly	45	532106596 Screw, Self-Tapping, Large 5/16-18 x 1.44
7	87810500 Locknut 5/16-24	46	532106151 Gear, Spur, 15 Teeth
8	532120951 Puck, Friction	47	532120407 Gear, Spur, 20 Teeth
9	532134399 Boot, Shifter	48	532106589 Gear, Spur, 25 Teeth
10	532002267 Ring, Retaining	49	532120408 Gear, Spur, 28 Teeth
11	532134793 * Assembly, Kit, Shim .625 Shaft	50	532105937 Gear, Spur, 31 Teeth
12	532138240 Bearing, Flange	51	532002226 Washer, Plain .632 x 1.00 x .060
13	532120415 Washer, Plain .632 x 1.38 x .046	52	532134401 Washer, Neoprene
14	532002257 Key, Woodruff, #9	53	532002264 Washer, Plain .758 x 1.25 x .031
15	532138233 Assembly, Kit, Input Shaft	54	532120474 Axle, L.H.
16	532106095 Pinion, Bevel, 14 Teeth	55	532120409 Gear, Miter, 15 Teeth
17	532105909 Ring, Retaining	56	532105941 Ring, Retaining
18	532105910 Chain, 24 Pitches	57	532110071 Gear, Spur, 32 Teeth
19	532105911 Bearing, Flange	58	532120952 Shaft, Cross
20	532138242 Gear, Spur, 14 Teeth	59	532106592 Gear, Miter, 15 Teeth
21	532138246 Collar, Clutch	60	532120475 Axle, R.H.
22	532138238 Assembly, Kit, Clutch Keys	61	532138247 Housing, Lower
23	532134791 Screw, Self-Tapping, with Sealer	62	532120961 Puck, Friction
24	532138245 Shaft, Intermediate	63	532007294 Disc, Brake
25	532002244 Key, Woodruff, #61	64	532108989 Spacer
26	532105916 Ring, Retaining	65	532120953 Jaw, Brake
27	532120470 Sprocket, 18 Teeth	66	532120954 Pin, Dowel
28	532110070 Spacer	67	532134799 Screw, Self-Tapping, Large 5/16-18 x 2.25
29	532109253 Gear, Spur, 40 Teeth	68	532138244 Lever, Actuating
30	532109254 Gear, Spur, 35 Teeth	69	532108996 Washer, Plain .321 x 1.00 x .055
31	532120405 Gear, Spur, 30 Teeth	70	532120956 Bracket, Anti-Rotation
32	532108980 Gear, Spur, 25 Teeth	71	532138241 Square Ring
33	532120406 Gear, Spur, 22 Teeth	72	532120416 Grease
34	532134796 Gear, Spur, 19 Teeth		
35	532105925 Washer, Plain .640 x 1.37 x .061		
36	532002232 Washer, Plain .632 x 1.00 x .026		
37	532108978 Spacer .630 x 1.00 x .169		
38	532108981 Assembly, Gear, Combination of 12 Teeth and 35 Teeth		
39	532124639 Shaft, Idler		

* Use in combinations to maintain proper clearances
 ** Order Key No. 15

NOTE: All component dimensions given in U.S. inches
 1 inch = 25.4 mm