

# **ECHO**®

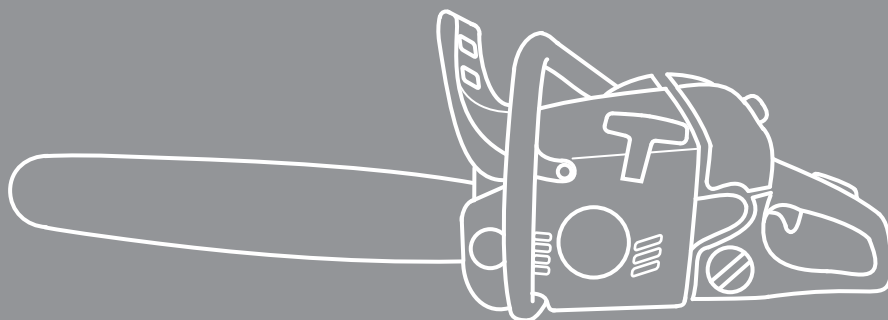

## **SERVICE MANUAL**

# **CS-600P**

Ord. No. 401-30

## INTRODUCTION

This service manual contains information for service and maintenance of **ECHO CHAIN SAW**, model **CS-600P**.

For systematic diagnosis, to avoid extra work, time loss and to meet Emission regulation, please refer to “Troubleshooting guide” that describes problems, testing, remedies and references. We recommend you make use of Operator’s Manual and Parts Catalogue together with this manual when servicing.

We are constantly working on technical improvement of our products. For this reason, technical data, equipment and design are subject to change without notice. All specifications, illustrations and directions in this manual are based on the latest product information available at the time of publication.

	Page		Page
<b>1 SERVICE INFORMATION</b> .....	2	<b>5 CLUTCH SYSTEM</b> .....	39
1-1 Specifications .....	2	5-1 Inspecting clutch parts .....	40
1-2 Technical data .....	3	5-2 Replacing clutch parts .....	41
1-3 Torque limits .....	4	5-3 Installing clutch assembly.....	41
1-4 Special repairing materials.....	5	<b>6 CHAIN BRAKE SYSTEM</b> .....	43
1-5 Service Limits .....	6	6-1 Disassembling chain brake .....	44
1-6 Special tools .....	7	6-2 Assembling brake parts.....	45
<b>2 STARTER SYSTEM</b> .....	8	<b>7 SAW CHAIN LUBRICATION SYSTEM</b> .....	46
2-1 Disassembling starter assembly.....	9	7-1 Inspecting oil cap and strainer.....	47
2-2 Replacing starter rope .....	10	7-2 Inspecting auto-oiler assembly and oil line.....	48
2-3 Assembling starter.....	11	7-3 Inspecting oil tank vent.....	49
2-4 Replacing starter pawl.....	13	7-4 Replacing oil line and grommet.....	50
<b>3 IGNITION SYSTEM</b> .....	14	7-5 Disassembling auto-oiler assembly.....	51
3-1 Troubleshooting guide.....	15	7-6 Inspecting V-ring.....	52
3-2 Testing spark .....	16	7-7 Assembling auto-oiler parts.....	53
3-3 Inspecting spark plug .....	16	<b>8 ENGINE</b> .....	54
3-4 Inspecting ignition switch.....	17	8-1 Testing cylinder compression .....	55
3-5 Replacing ignition switch .....	18	8-2 Cleaning cooling air passages .....	55
3-6 Inspecting ignition coil resistance.....	19	8-3 Inspecting muffler and exhaust port .....	56
3-7 Replacing spark plug cap and coil.....	20	8-4 Testing crankcase and cylinder seal.....	57
3-8 Replacing ignition coil.....	20	8-5 Inspecting cylinder.....	58
3-9 Setting pole shoe air gaps.....	21	8-6 Inspecting piston and piston ring.....	59
3-10 Inspecting flywheel and key .....	21	8-7 Replacing oil seal .....	60
<b>4 FUEL SYSTEM</b> .....	23	8-8 Disassembling crankcase.....	60
4-1 Inspecting air filter .....	24	8-9 Replacing ball bearing and oil seal.....	61
4-2 Inspecting fuel cap and fuel strainer.....	24	8-10 Assembling crankshaft and crankcase.....	62
4-3 Inspecting fuel tank and line.....	25	8-11 Installing piston.....	63
4-4 Inspecting and replacing tank vent.....	26	8-12 Installing piston ring and cylinder .....	64
4-5 Replacing fuel line .....	28	<b>9 REAR HANDLE AND CONTROL SYSTEM</b> .....	65
4-6 Adjusting carburetor .....	29	9-1 Replacing cushions .....	66
4-6-1 General adjusting rules .....	29	9-2 Replacing throttle trigger .....	67
4-6-2 Presetting idle adjust screw, L mixture needle and H mixture needle .....	29	<b>10 GUIDE BAR MOUNTING SYSTEM</b> .....	69
4-6-3 Adjusting carburetor .....	31	10-1 Replacing chain tensioner .....	70
4-7 Air shutter .....	32	10-2 Replacing guide bar stud.....	70
4-8 Testing carburetor.....	33	10-3 Installing guide bar stud .....	71
4-9 Inspecting crankcase pulse passage .....	34	<b>11 MAINTENANCE GUIDE</b> .....	72
4-10 Inspecting metering lever height .....	34	11-1 Troubleshooting guide .....	72
4-11 Inspecting inlet needle valve .....	35	11-2 Disassembly Chart .....	74
4-12 Inspecting diaphragm .....	36	11-3 Service Intervals.....	75
4-13 Replacing Welch plug.....	37	<b>INDEX</b> .....	76
4-14 Installing carburetor.....	38		

### 1 SERVICE INFORMATION

#### 1-1 Specifications

Dimensions	Length	mm(in)	448 (17.64)
	Width	mm(in)	245 (9.65)
	Height	mm(in)	292 (11.50)
Dry weight*		kg(lb)	5.9 (13.0)
Engine	Type	KIORITZ, air-cooled, two-stroke, single cylinder Ventilated piston, Semi-automatic decompression	
	Rotation	Clockwise as viewed from the output end	
	Displacement	cm <sup>3</sup> (in <sup>3</sup> )	59.8 (3.649)
	Bore	mm(in)	45.0 (1.772)
	Stroke	mm(in)	37.6 (1.480)
	Compression ratio		6.8
Carburetor	Type	Diaphragm horizontal-draught	
	Model	Walbro HDA-268	
	Venturi size-Throttle bore	mm(in)	15.08 - 19.03 (0.594 - 0.749)
Ignition	Type	CDI (Capacitor discharge ignition) system Digital magneto	
	Spark plug	BPM8Y	
Exhaust	Muffler type	Spark arrester muffler	
Starter	Type	Automatic rewind	
	Rope diameter x length	mm(in)	4.0 x 950 (0.15 x 37.4)
Fuel	Type	Premixed two-stroke fuel	
	Mixture ratio	50 : 1 (2 %)	
	Gasoline	Minimum 89 octane gasoline	
	Two-stroke air cooled engine oil	ISO-L-EGD (ISO/CD13738), JASO M345-FC/FD	
	Tank capacity	L (U.S.fl.oz.)	0.57 (19.3)
Clutch	Type	Inboard clutch : Centrifugal, 3-shoe slide with 3-tension spring	
Guide bar / Saw chain lubrication type		Automatic with volume adjuster	
	Tank capacity, oil	L (U.S.fl.oz.)	0.3 (10.1)
Sprocket	Type	Floating rim	
	Number of teeth	7	
	Pitch	in	3/8

\* Without guide bar and saw chain.

#### OREGONE Saw chain 72LPX

Cutting devices				
Guide bar	Part No.	16D0PS3860	20D0PS3870	24D0PS3881
	Called length	in	16	20
	Gauge	in	0.050	
Saw chain	Number of drive links	60	70	81
	Pitch	in	3/8	
	Gauge	in	0.050	

## OREGONE Saw chain 72V

Cutting devices						
Guide bar	Part No.	16D0PS3860	20D0PS3870	24D0PS3881	27D0PS3893	
	Called length	in	16	20	24	27
	Gauge	in	0.050			
Saw chain	Number of drive links	60	70	81	93	
	Pitch	in	0.375			
	Gauge	in	0.050			

## 1-2 Technical data

Engine			
Idling speed	rpm	2,800	- 200 + 400
Wide open throttle speed*	rpm	12,000 - 13,000	
Clutch engagement speed	rpm	4,000	
Service limit speed <sup>†</sup>	rpm	3,500	
Compression pressure	MPa (kgf/cm <sup>2</sup> ) (psi)	0.94 (9.6) (136)	
Ignition system			
Spark plug gap	mm(in)	0.6 - 0.7 (0.024 - 0.028)	
Minimum secondary voltage at 1,500 rpm	kV	15	
Secondary coil resistance	kΩ	1.7 - 2.2	
Pole shoe air gaps	mm(in)	0.30 - 0.40 (0.012 - 0.016)	
Ignition timing	at 3,000 rpm	°BTDC	11
	at 8,000 rpm	°BTDC	32
	at 12,000 rpm	°BTDC	31
PET-9000	Parameter 1	324	
	Parameter 2	00	
Carburetor			
Idle adjust screw initial setting	turn in**	2 3/8	
L mixture needle initial setting	turns back***	2	
H mixture needle initial setting	turns back***	3/4	
Test Pressure, minimum	MPa (kgf/cm <sup>2</sup> ) (psi)	0.05 (0.5) (7.0)	
Metering lever height	mm(in)	Flush with diaphragm seat	
Chain oil discharge volume at 7,000 rpm	mL/min(U.S.fl.oz./min)	Adjustable 1.5 - 13 (0.05 - 0.39) (Factory set 7.0 mL/min)	

BTDC: Before top dead center.

\*With 20 in. guide bar and properly adjusted saw chain.

\*\*Set idle adjust screw to the point that its tip just contacts throttle plate before initial setting.

\*\*\*Turn L/H mixture needles counterclockwise from point that needle is lightly seated.

<sup>†</sup> If clutch engagement speed is lower than service limit speed, replace clutch assembly with new one.

## 1-3 Torque limits

Descriptions		Size	kgf·cm	N·m	in·lbf	
Starter system	Starter pawl	M5* <sup>†</sup>	60 - 90	6 - 9	50 - 80	
	Starter center shaft screw	M5*	30 - 45	3 - 4.5	25 - 40	
	Starter case	M5	50 - 70	5 - 7	45 - 60	
Ignition system	Magneto rotor (Flywheel)	M8	230 - 270	23 - 27	200 - 235	
	Ignition coil	M4	60 - 90	6 - 9	50 - 80	
	Spark plug	M14	130 - 170	13 - 17	113 - 150	
Fuel system	Carburetor	M5	30 - 45	3 - 4.5	25 - 40	
	Intake bellows	M5	60 - 90	6 - 9	50 - 80	
Clutch	Clutch hub	LM10	300 - 400	30 - 40	250 - 350	
Engine	Crankcase	M5 <sup>†</sup>	60 - 90	6 - 9	50 - 80	
	Cylinder	M5 <sup>†</sup>	70 - 110	7 - 11	60 - 95	
	Cylinder cover	M5	60 - 90	6 - 9	50 - 80	
	Muffler	M5*	70 - 110	7 - 11	60 - 95	
	Muffler lid	M4	15 - 25	1.5 - 2.5	13 - 22	
Others	Auto-oiler	M4	35 - 50	3 - 5	25 - 45	
	Compression spring	Cushion bracket	M5	30 - 40	3 - 4	25 - 35
		Crankcase	M5	60 - 80	6 - 8	50 - 70
		Front handle	M5	40 - 60	4 - 6	35 - 50
		M6	40 - 50	4 - 5	35 - 45	
	Rear handle	M5	40 - 60	4 - 6	35 - 50	
	Brake lever (Hand guard)	Starter side	M5	30 - 50	3 - 5	25 - 40
		Sprocket side	M5	60 - 90	6 - 9	50 - 80
	Brake cover	M5*	40 - 60	4 - 6	35 - 50	
	Sprocket guard plate	M4*	15 - 25	1.5 - 2.5	13 - 22	
	Spike	M4	60 - 90	6 - 9	50 - 80	
	Ignition switch	M10	15 - 30	1.5 - 3	13 - 25	
	Guide bar	M8	200 - 230	20 - 23	175 - 200	
	Regular bolt, nut and screw	M3	6 - 10	0.6 - 1	5 - 9	
		M4	15 - 25	1.5 - 2.5	13 - 22	
M5		25 - 45	2.5 - 4.5	22 - 40		
M6		45 - 75	4.5 - 7.5	40 - 65		
M8		110 - 150	11 - 15	95 - 130		

LM: Left-hand thread

\*Thread locking sealant (See next page)

<sup>†</sup> The torque difference between four bolts should not exceed 20 kgf·cm (2N·m, 17in·lbf) per bolt.

1-4 Special repairing materials

Material	Location	Remarks
Adhesive	Guide bar stud	Loctite #609, ThreeBond 1373 or equivalent
	Starter center shaft screw	Loctite #222, ThreeBond1342 or equivalent
Grease	Auto-oiler worm	Lithium based grease or ECHO XTended Protection™ Lubricant
	Clutch needle bearing	
	Rubber cushion, inside	
	Choke knob	
	Rewind spring	
	Oil seal inner lips	
	Starter center shaft	
	Brake cover	
	Chain brake (metal contact part)	Molybdenum grease (approx. 1 gram)
Thread locking sealant	Muffler	Loctite #242, ThreeBond #1324 or equivalent
	Sprocket guard plate	
	Starter pawl	

### 1-5 Service Limits

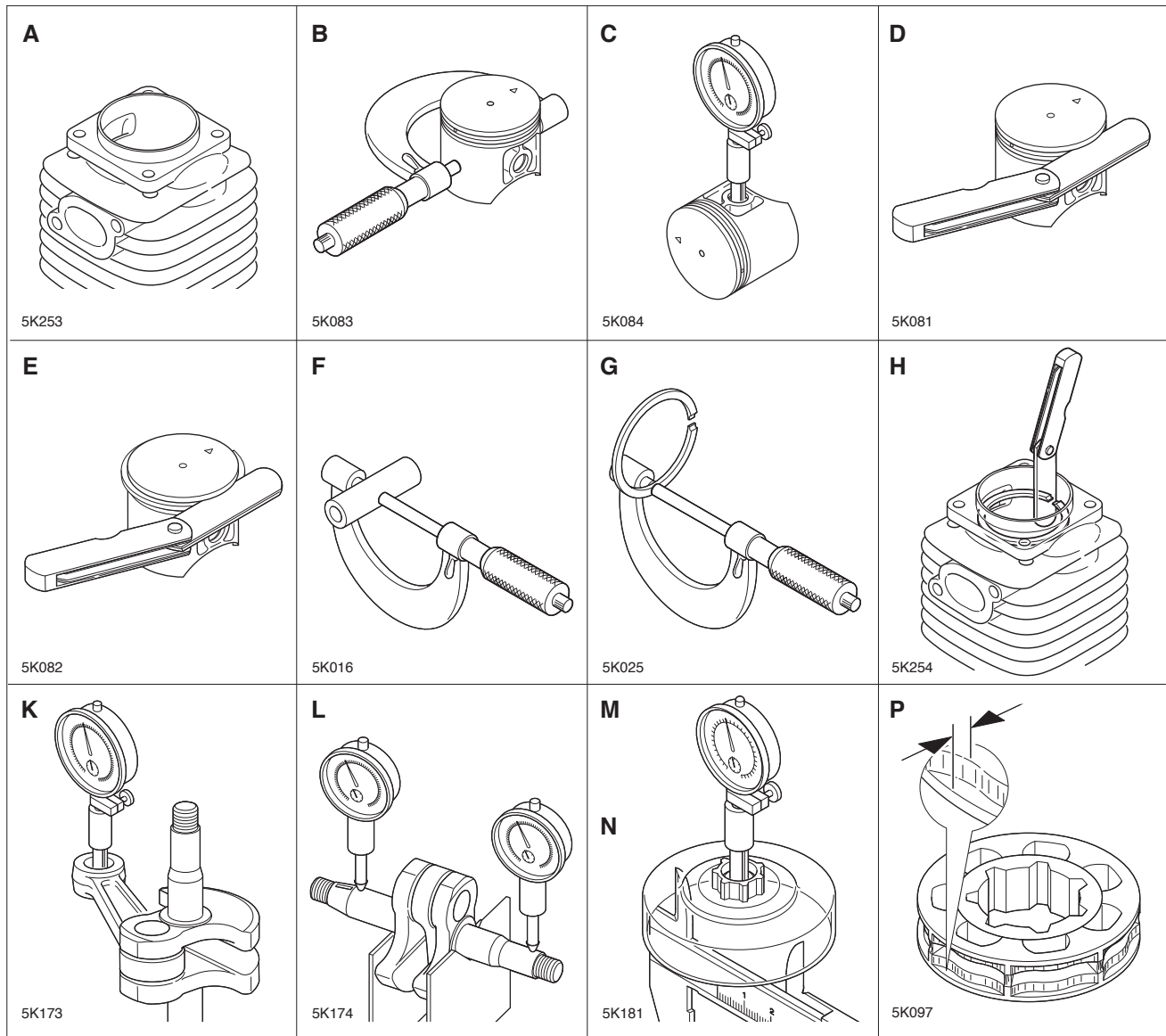

Description		mm (in)	
A	Cylinder bore	When plating is worn and aluminum can be seen	
B	Piston outer diameter	Min.	44.90 (1.768)
C	Piston pin bore	Max.	11.030 (0.4343)
D	Piston ring groove	Max.	1.6 (0.063)
E	Piston ring side clearance	Max.	0.1 (0.004)
F	Piston pin outer diameter	Min.	10.98 (0.4323)
G	Piston ring width	Min.	1.45 (0.057)
H	Piston ring end gap	Max.	0.5 (0.02)
K	Con-rod small end bore	Max.	15.025 (0.5915)
L	Crankshaft runout	Max.	0.01 (0.001)
M	Sprocket bore	Max.	13.90 (0.5472)
N	Clutch drum bore	Max.	71.5 (2.81)
P	Sprocket wear limit	Max.	0.5 (0.02)



1-6 Special tools

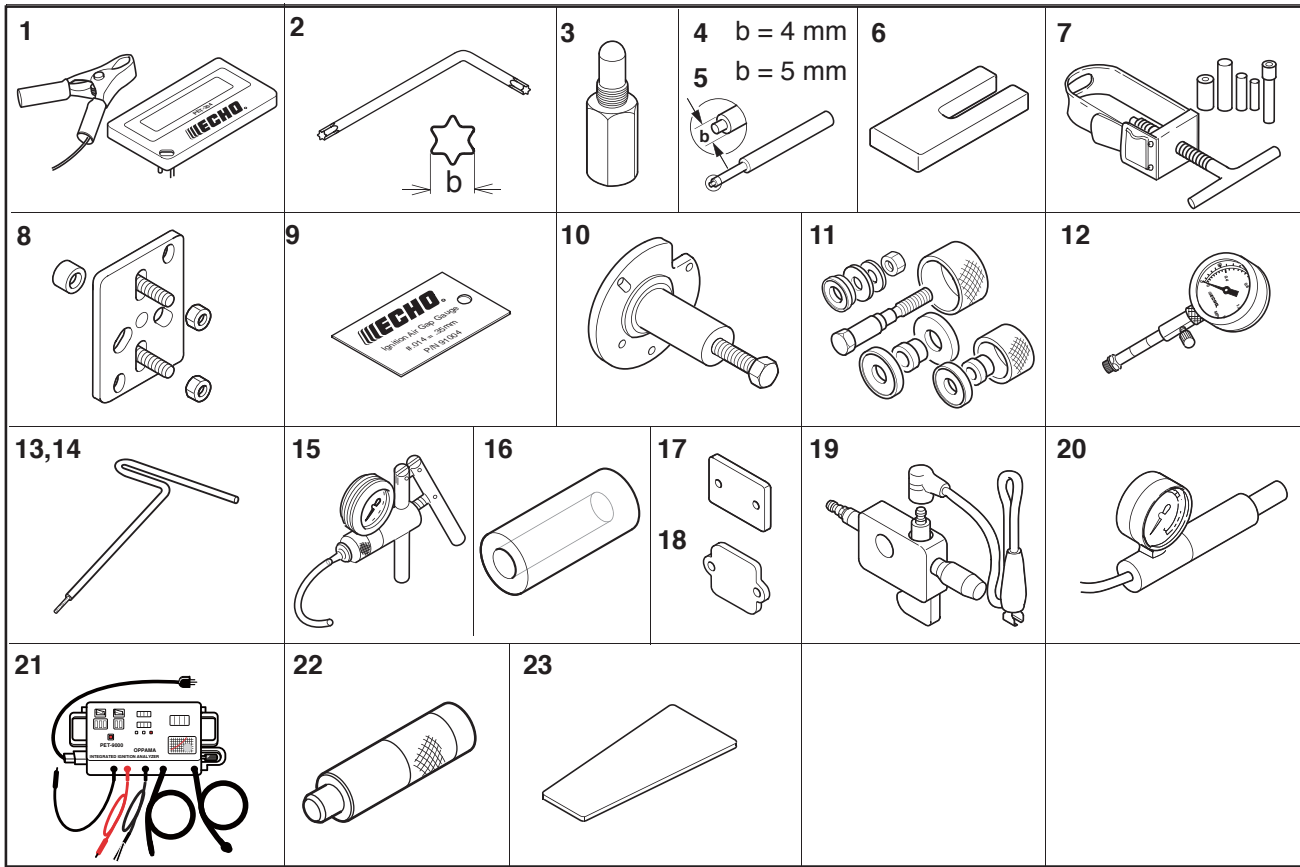

Key	Part Number	Description	Used for:
1	G310-000050	Tachometer PET-304	Measuring engine speed to adjust carburetor
2	X605-000050	Torx L wrench	Removing and installing bolt
3	897537-30130	Piston stopper	Locking crankshaft rotation
4	897724-01361	Spring pin tool (4 mm)	Removing and installing spring pin (4 mm dia)
5	897724-02831	Spring pin tool (5 mm)	Removing and installing spring pin (5 mm dia)
6	897719-02830	Piston holder	Making piston steady to remove and install piston / rings
7	897702-30131	Piston pin tool	Removing and installing piston pin
8	897501-03938	Puller	Removing magneto rotor
9	91004	Module air gap gauge	Adjusting pole shoe air gaps
10	897502-19830	Crankcase tool	Separating crankcase
11	897701-14732	Bearing tool	Removing and installing ball bearings on crankcase
12	91037	Compression gauge	Measuring cylinder compression
13	89801	Limiter cap removal tool	Removal limiter cap (Left hand thread 2.5 mm)
14	89802	Limiter cap removal tool	Removal limiter cap (Left hand thread 3.0 mm)
15	91024	Pressure tester	Testing crankcase leakages
16	897726-16431	Oil seal tool	Installing starter side oil seal
17	897826-16131	Pressure rubber plug	Plugging intake port to test crankcase / cylinder leakages
18	897827-16131	Pressure plate	Plugging intake port to test crankcase / cylinder leakages
19	897800-79931	Spark tester	Checking ignition system
20	897803-30133	Pressure tester	Testing carburetor leakages
21	900300	Ignition Analyzer : PET-9000	Measuring Ignition timing, Primary/Secondary voltage engine speed
22	897714-12330	Oil seal tool	Installing crankcase side oil seal
23	91041	Pressure rubber plug	Plugging exhaust port to test crankcase / cylinder leakages

2 STARTER SYSTEM

- (A) Starter case
- (B) Rope guide
- (C) Starter grip
- (D) Rewind spring
- (E) Rewind spring case
- (F) Rope reel

- (G) Starter rope
- (H) Fan cover
- (J) Starter pawl
- (K) Flywheel

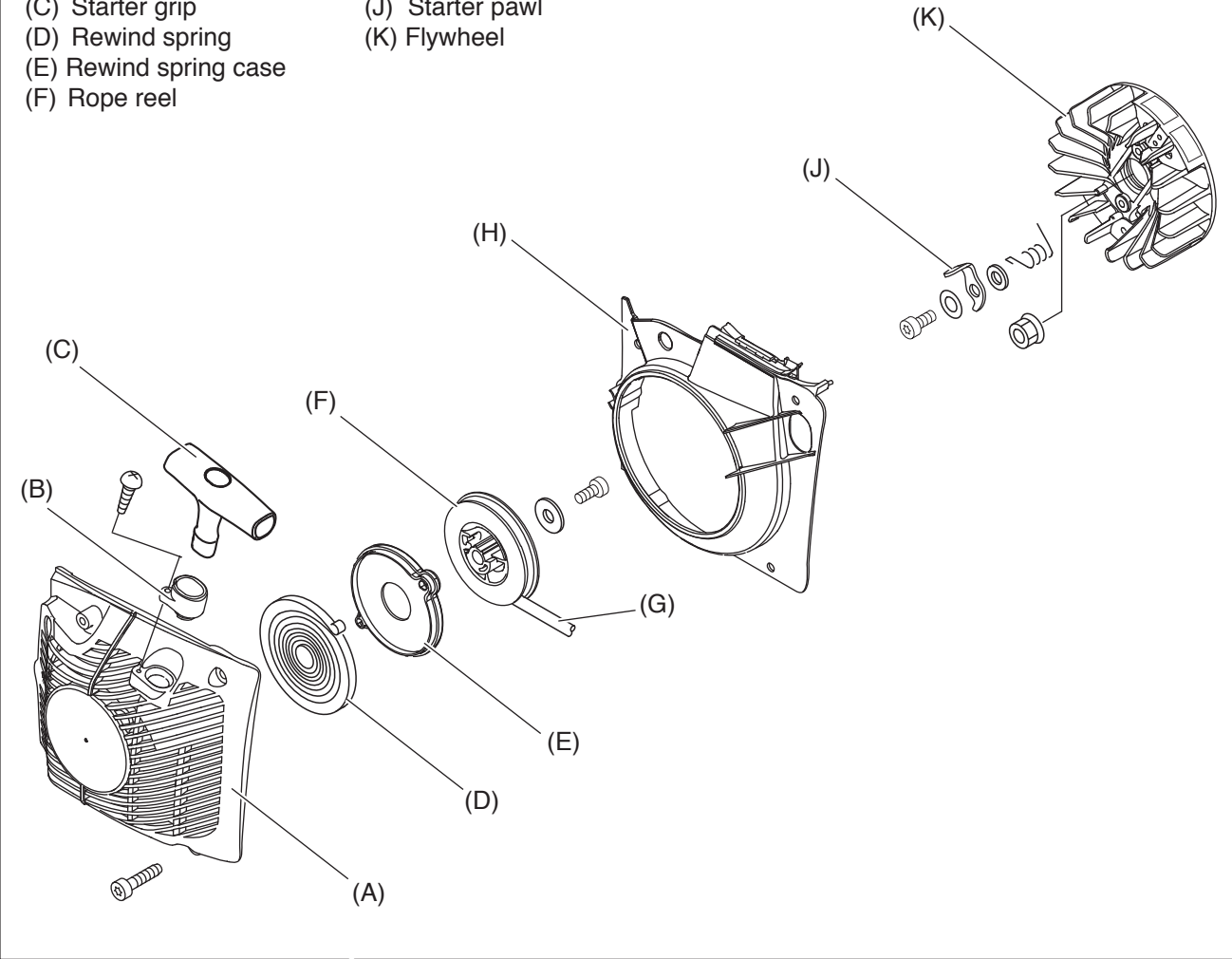

## 2-1 Disassembling starter assembly

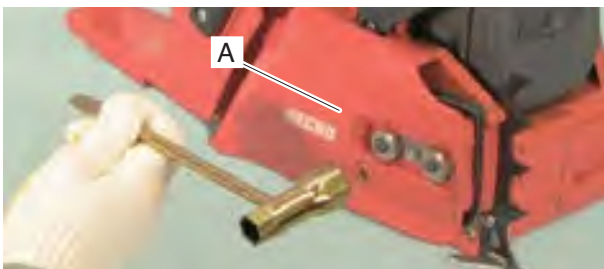

1. Remove sprocket guard (A).



2. Remove brake lever (B).



3. Remove four screws and remove starter assembly (C) from unit.

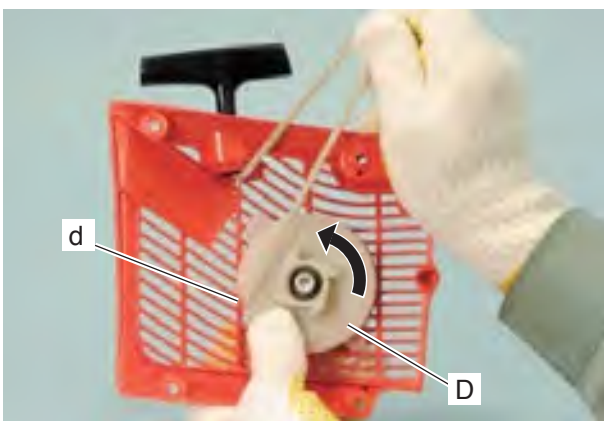

4. Pull out starter rope about 30 cm (12 in) and hold rope reel (D) by hand. Loop excess rope in rope reel notch (d) as shown.

5. Rotate rope reel (D) counterclockwise to release tension of rewind spring.

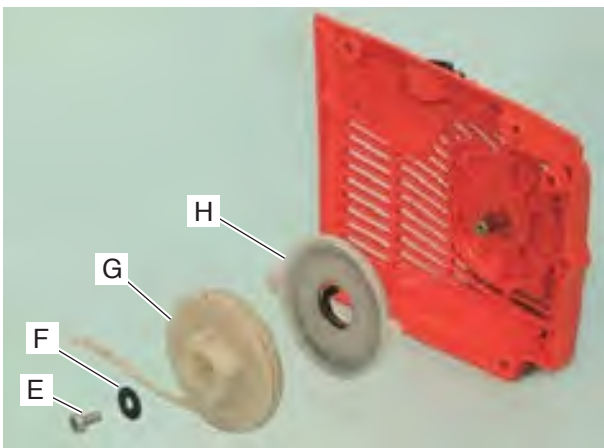

6. Remove bolt (E).

7. Remove washer (F) and starter drum (G).

8. Carefully remove rewind spring and case (H) as one piece. Rewind spring is under tension and may release unexpectedly.

**WARNING**  **DANGER**

**Wear eye protection and take care when removing starter drum. Rewind spring may unwind suddenly and cause personal injury.**

## 2-2 Replacing starter rope

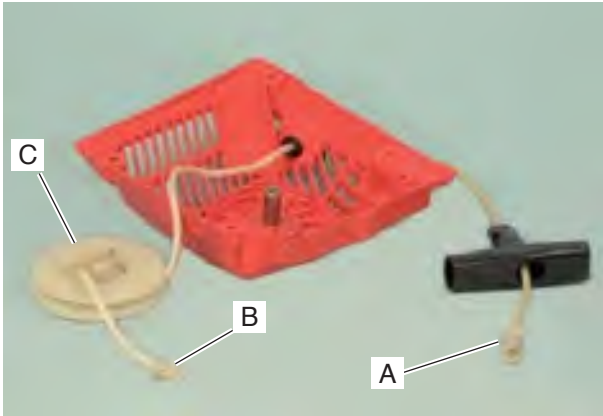

1. Pull out and untie knot (A).
2. Pull knot (B) to remove rope from rope reel (C).

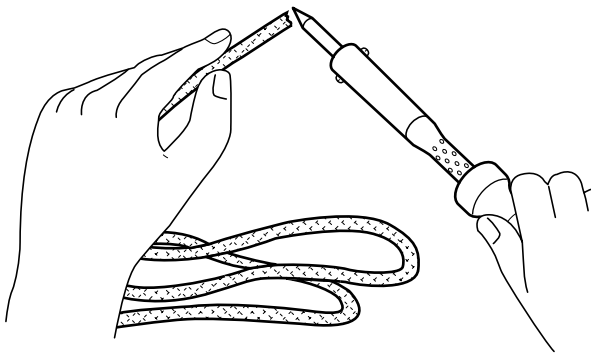

3. When installing a new starter rope, singe both ends of the rope to prevent fraying.

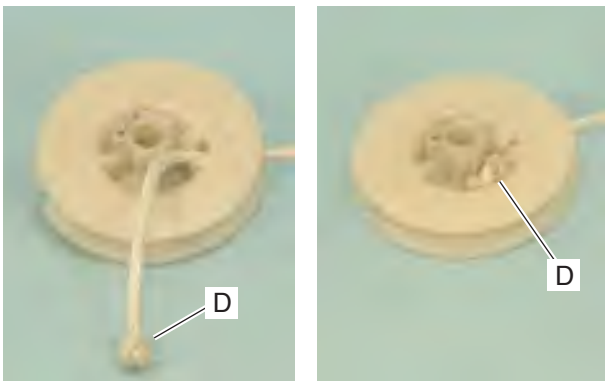

4. Make a knot (D) at end of starter rope and pass the rope through hole of rope reel, then press the knot (D) into recess as shown.

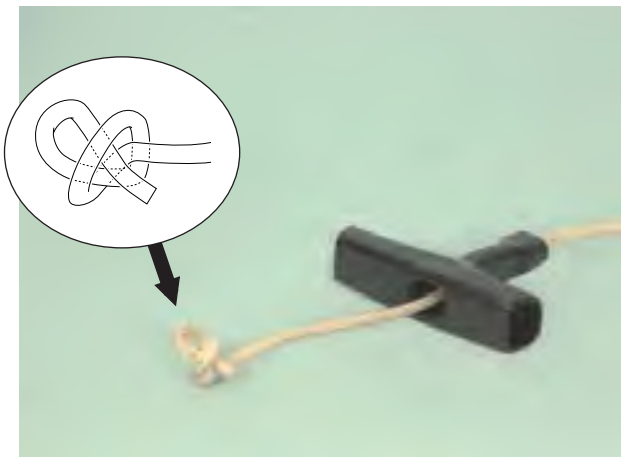

5. Pass the other end of starter rope through rope guide on starter case, then pass starter rope through starter grip and make a knot as shown.
6. Tighten knot. Push knot into recess of starter grip.

## 2-3 Assembling starter



1. If rewind spring (A) is removed from spring case (B), rewind inside case as shown.

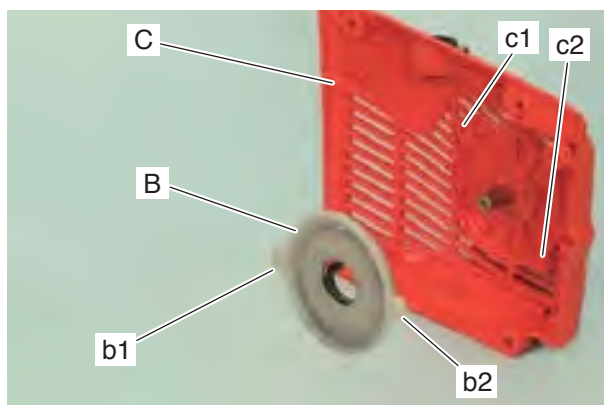

2. Carefully install rewind spring and case (B) on starter case (C) as one piece. Match large ear (b1) and small ear (b2) with posts (c1) and (c2) on starter case.

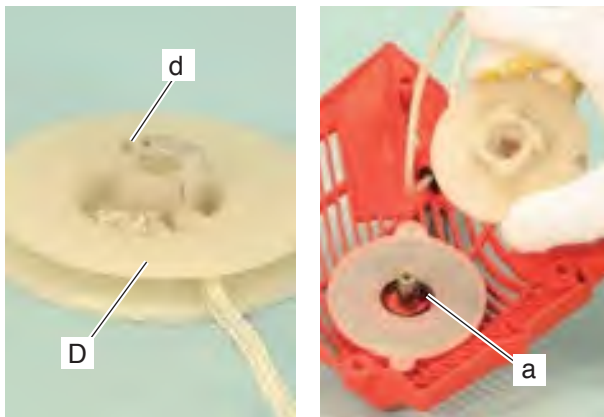

3. Assemble rope reel (D) engaging hook (d) with hook (a) of rewind spring.

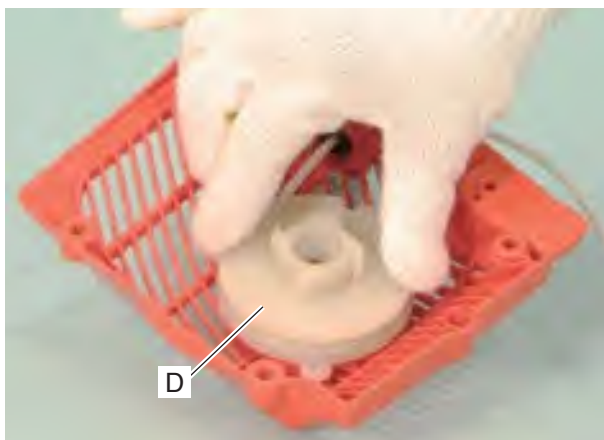

4. Check for proper engagement of rewind spring and rope reel by turning rope reel (D) clockwise and counterclockwise.

## 2-3 Assembling starter (continued)



5. Reinstall washer (E) and bolt (F) on starter post.

6. Pull out starter rope inside starter case. Rotate rope reel clockwise several turns with starter rope hooked at notch (G) as shown. Hold rope reel to prevent it from unwinding and pull out starter grip to take the rope slack.





7. Pull starter several times to check rewind spring tension. If starter is not rewinding fully, increase spring tension by rotating rope reel one more turn clockwise following above step (6).

8. Pull out starter rope all the way, and check that rope reel can be rotated an additional half or more turn clockwise as shown, to prevent rewind spring from breaking.

9. If rope reel can not turned clockwise, reduce tension by rotating rope reel counterclockwise one turn with starter rope hooked at notch (G).

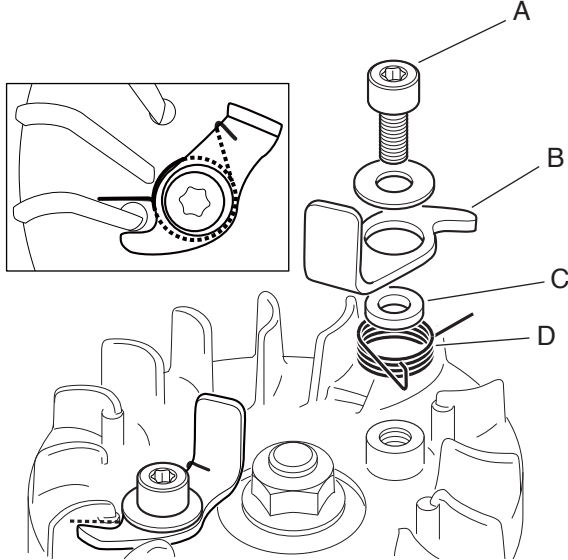
## 2-4 Replacing starter pawl

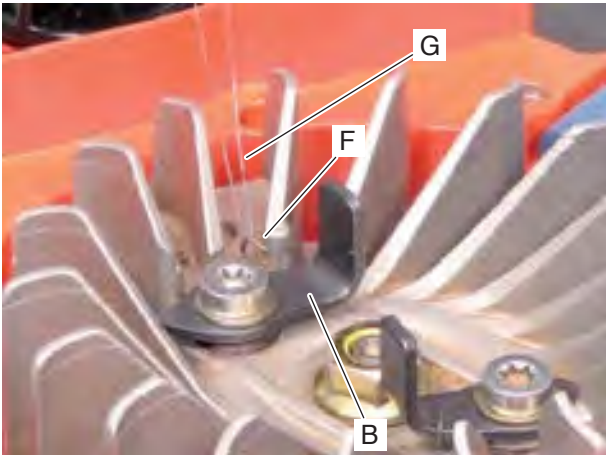





1. Remove starter assembly from unit.
2. Loosen bolt (A) and remove washer, pawl (B), spacer (C) and torsion spring (D). Replace damaged or worn parts.
 

**NOTE:** When it is hard to loosen bolt, install piston stopper 897537-30130 (E) in spark plug hole to stop crankshaft rotation and remove bolt easily.
3. Install torsion spring, spacer, pawl, washer and bolt. To avoid pinching of torsion spring, install these parts without setting the end (F) of torsion spring on starter pawl. The bolt is pre-coated with sealant on the thread. If the sealant is peeled off, apply thread locating sealant (Loctite #242, Three-Bond #1324 or equivalent).
4. Using fine wire (G) or appropriate tool, place the end (F) of torsion spring on pawl (B), by hooking and passing under pawl as shown. Remove fine wire or tool.
5. Make sure pawl can move smoothly. If it does not move smoothly, check parts for correct installation.

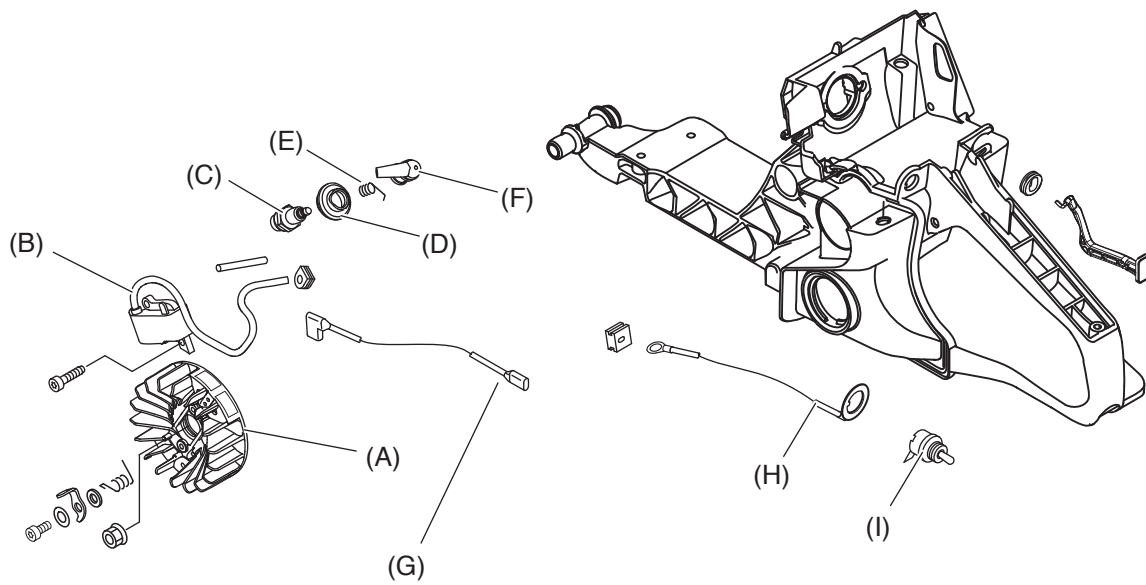
## 3 IGNITION SYSTEM

- (A) Flywheel
- (B) Ignition coil
- (C) Spark plug
- (D) Cap cover
- (E) Spark plug cap coil
- (F) Spark plug cap
- (G) Switch lead
- (H) Ground lead
- (I) Ignition switch





3-1 Troubleshooting guide

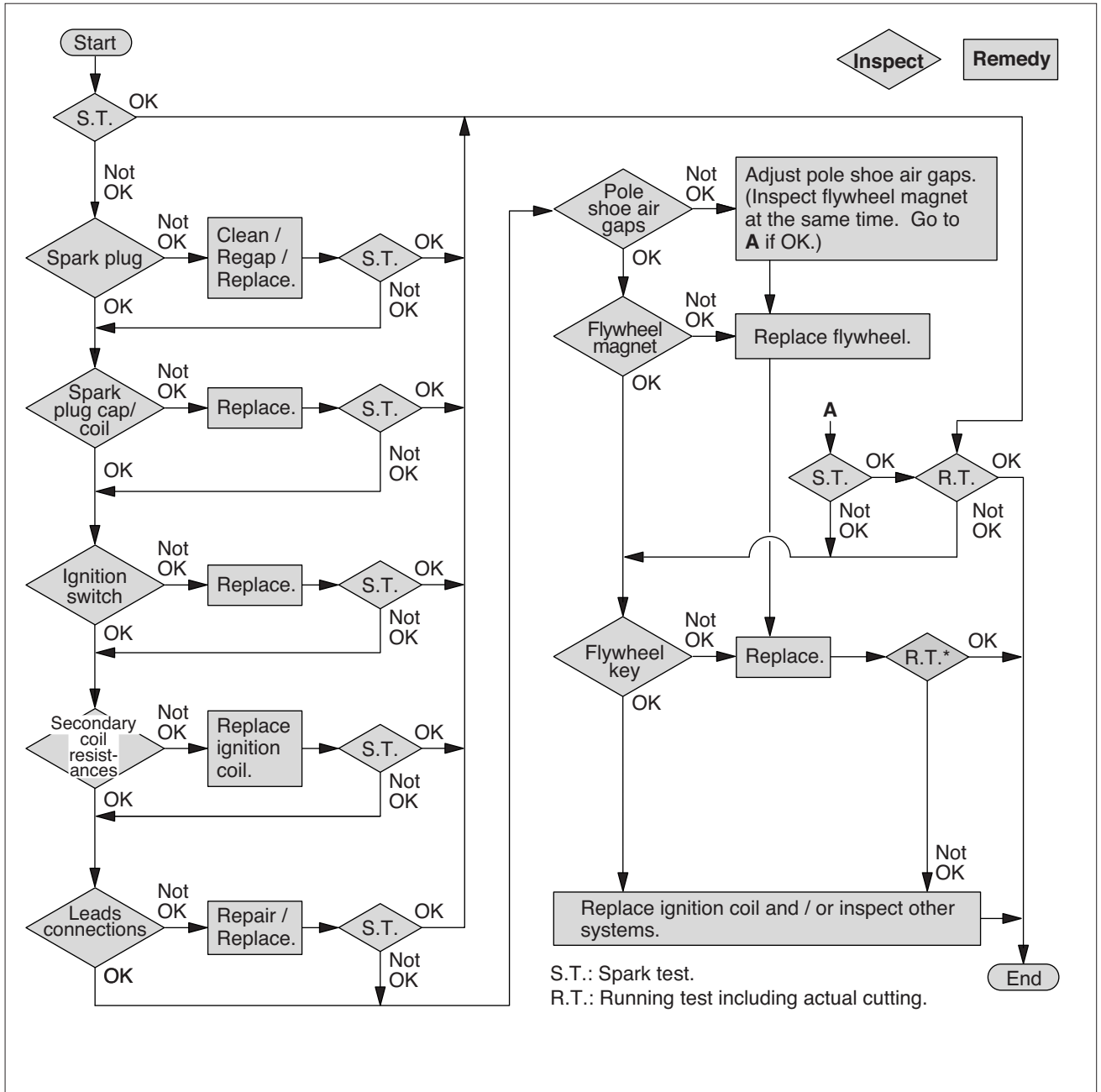

## 3-2 Testing spark

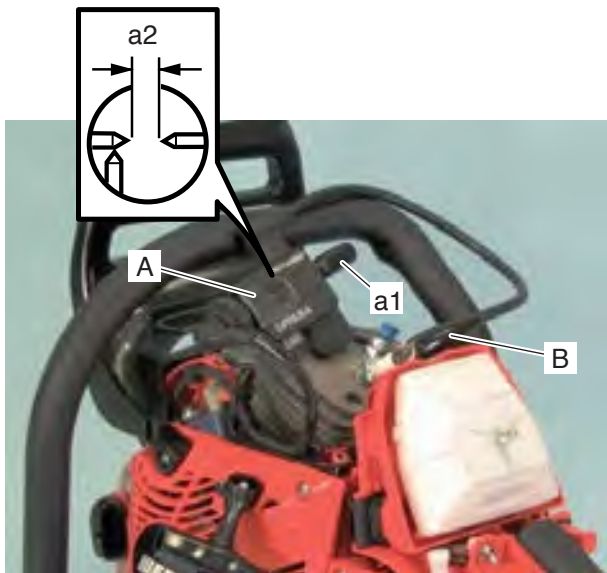

1. Remove cleaner lid and cylinder cover. Remove spark plug cap from spark plug.
2. Connect spark tester 990511-30023 (A) to high tension lead and connect tester lead (B) on spark plug.
3. Screw in adjuster (a1) until the needle tips contact. Turn out adjuster (a1) 4 turns to set spark tester gap (a2) to 4 mm (0.16 in).
4. Turn ignition switch to "I" position. Pull starter grip several times.
5. If spark is steady blue or white at the tester gap, ignition system is considered good. Go to inspecting spark plug.
6. If no spark exists or spark is intermittent in yellow, orange, or red, continue with further inspection.

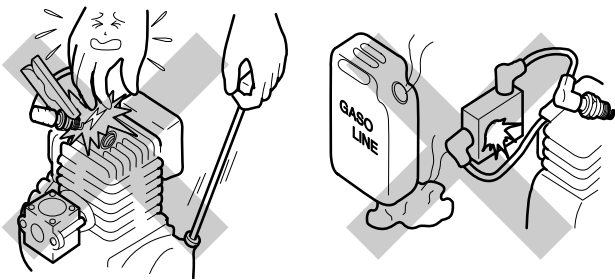
**DANGER**

- \*Do not test near spark plug hole without spark plug installed, otherwise there is a chance to ignite fuel mixture inside cylinder.
- \*Do not touch metal parts of spark tester while performing the test to avoid receiving electrical shock.
- \*Do not check spark in area where gasoline is spilled or flammable gases may exist.

## 3-3 Inspecting spark plug

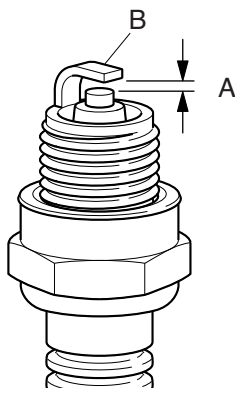

1. Remove spark plug to inspect for fouling, cracked or broken insulator, cracked outer electrode, or rounded center electrode. Clean or replace spark plug as required.

2. Set spark plug gap (A) by bending outer electrode (B).

Standard : 0.6 to 0.7 mm (0.024 to 0.028 in)

**NOTE:** Take care not to crack outer electrode when bending.

3. If engine does not start with correct spark plug, inspect if spark plug is wet or dry. If it is excessively wet or dry, inspect fuel system.

### 3-4 Inspecting ignition switch

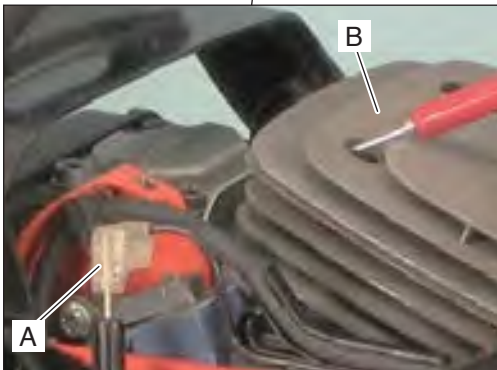
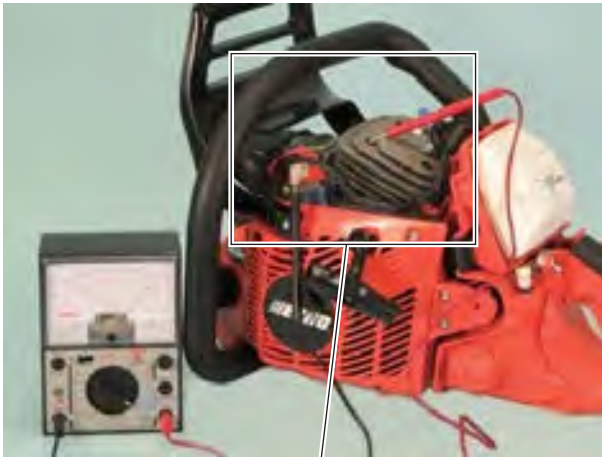

1. Remove cleaner lid and cylinder cover.
2. Remove switch lead (A) from ignition coil.
3. Connect one probe of Ohm-meter or multi-meter to switch lead. Connect the other probe to cylinder fin (B).
4. When ignition switch is in "I" position, tester should indicate infinite resistance.
5. When ignition switch is in "O (STOP)" position, tester should show that the circuit is in conducting state (closed circuit).
6. If ignition switch is defective, replace with a new one.

### 3-5 Replacing ignition switch



1. Remove cleaner lid and cylinder cover.
2. Remove two bolts and remove cleaner case (A).

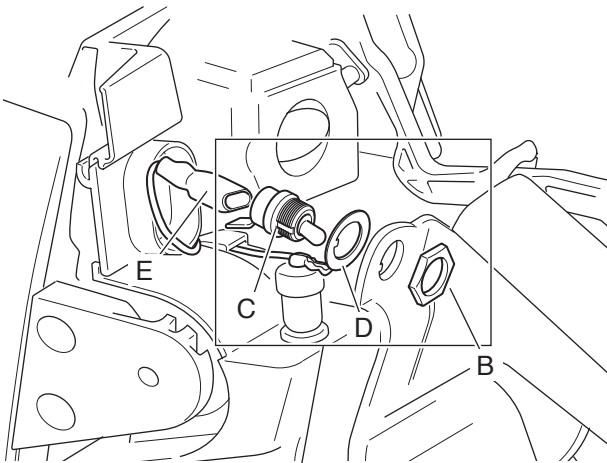

3. Loosen nut (B), and remove ignition switch (C) and ground lead (D) from the unit. Remove switch lead (E) from ignition switch.

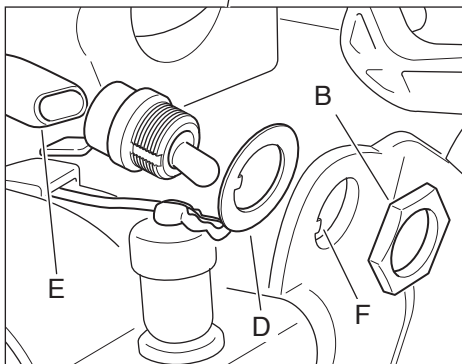

4. Assemble ground lead (D) and new ignition switch on the unit, aligning notch of ignition switch with tab (F) of the unit. Fasten nut (B) on ignition switch.
5. Assemble switch lead (E) to ignition switch.

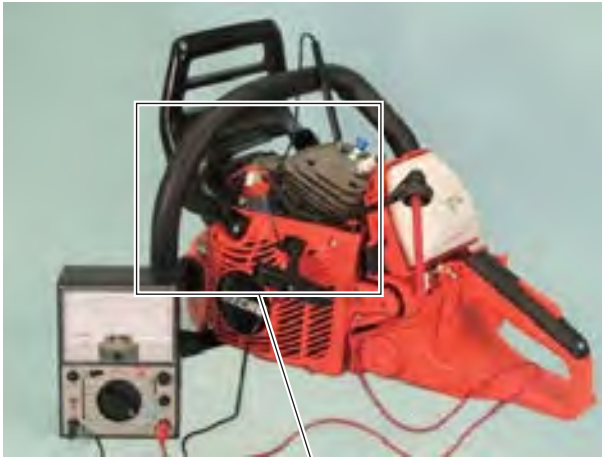
**3-6 Inspecting ignition coil resistance**

1. Remove cleaner lid and cylinder cover.
2. Connect one probe of Ohm-meter or multimeter to spark plug cap coil (A).
3. Connect the other probe to cylinder fin (B) to measure secondary coil resistance. Secondary coil resistance should be in the range of 1.7 to 2.2 k $\Omega$ .
4. If the meter reading indicates infinite resistance, remove spark plug cap and spark plug cap coil, and measure resistance between the conduction wire of high tension lead and ignition coil core.
5. If the reading at step 2 or 3 is not in the range of 1.7 to 2.2 k $\Omega$ , replace with a new ignition coil (Go to "3-8 Replacing ignition coil").

### 3-7 Replacing spark plug cap and coil

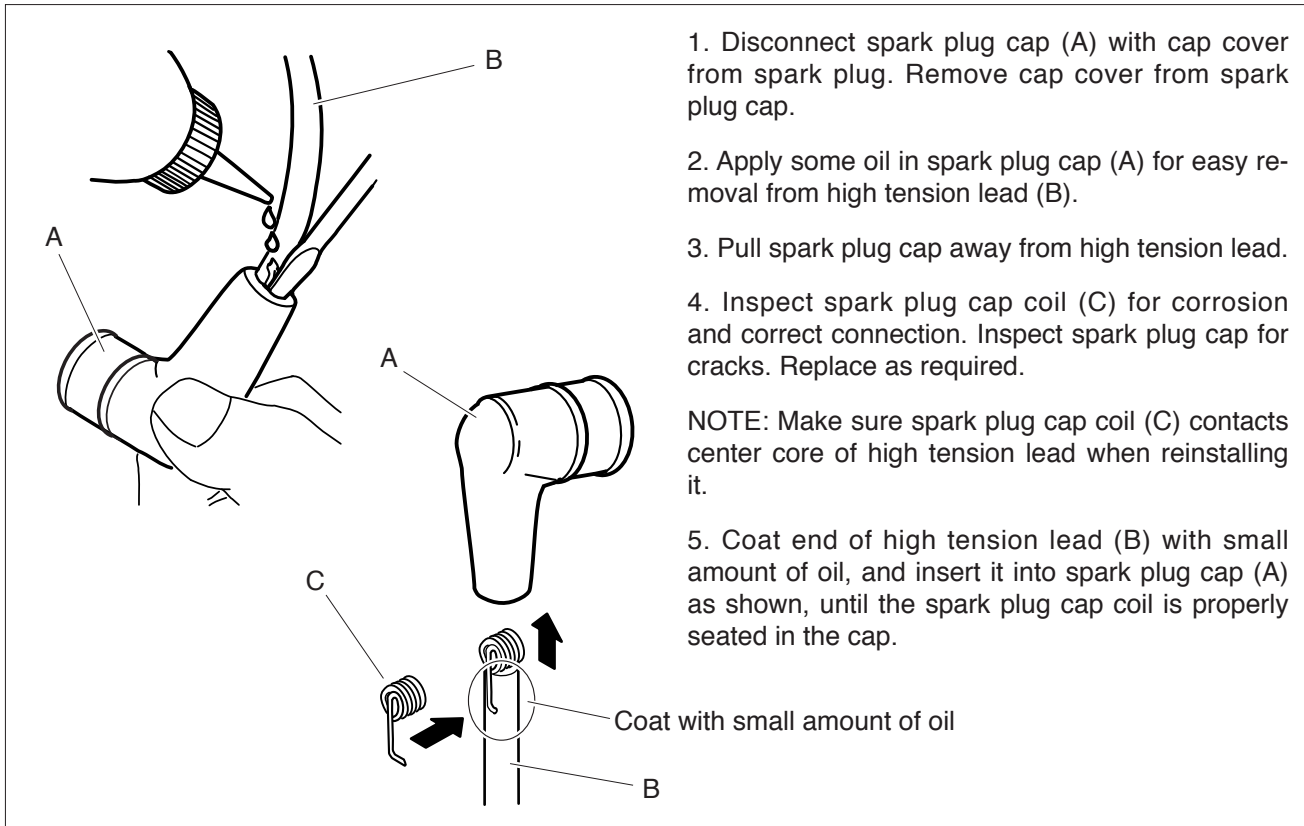

1. Disconnect spark plug cap (A) with cap cover from spark plug. Remove cap cover from spark plug cap.

2. Apply some oil in spark plug cap (A) for easy removal from high tension lead (B).

3. Pull spark plug cap away from high tension lead.

4. Inspect spark plug cap coil (C) for corrosion and correct connection. Inspect spark plug cap for cracks. Replace as required.

NOTE: Make sure spark plug cap coil (C) contacts center core of high tension lead when reinstalling it.

5. Coat end of high tension lead (B) with small amount of oil, and insert it into spark plug cap (A) as shown, until the spark plug cap coil is properly seated in the cap.

### 3-8 Replacing ignition coil

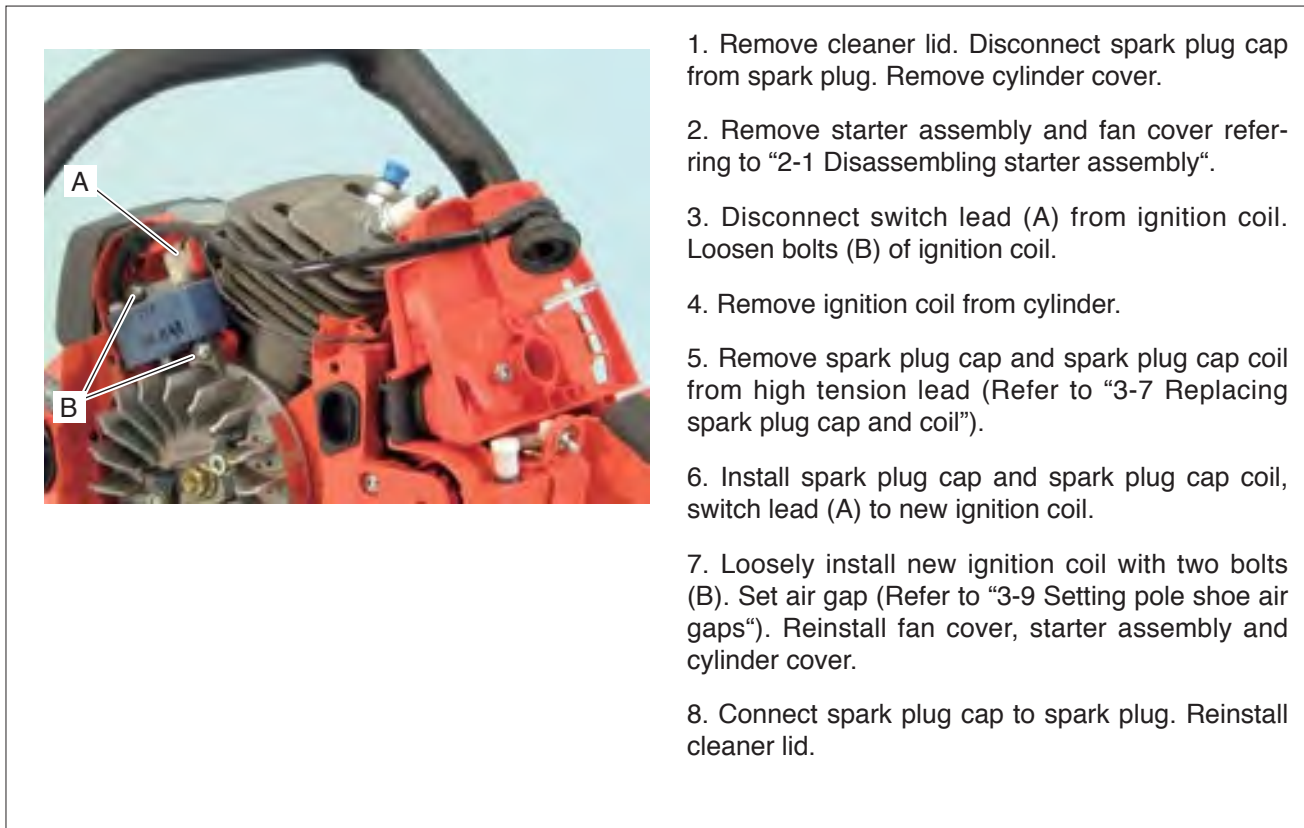

1. Remove cleaner lid. Disconnect spark plug cap from spark plug. Remove cylinder cover.

2. Remove starter assembly and fan cover referring to "2-1 Disassembling starter assembly".

3. Disconnect switch lead (A) from ignition coil. Loosen bolts (B) of ignition coil.

4. Remove ignition coil from cylinder.

5. Remove spark plug cap and spark plug cap coil from high tension lead (Refer to "3-7 Replacing spark plug cap and coil").

6. Install spark plug cap and spark plug cap coil, switch lead (A) to new ignition coil.

7. Loosely install new ignition coil with two bolts (B). Set air gap (Refer to "3-9 Setting pole shoe air gaps"). Reinstall fan cover, starter assembly and cylinder cover.

8. Connect spark plug cap to spark plug. Reinstall cleaner lid.

## 3-9 Setting pole shoe air gaps

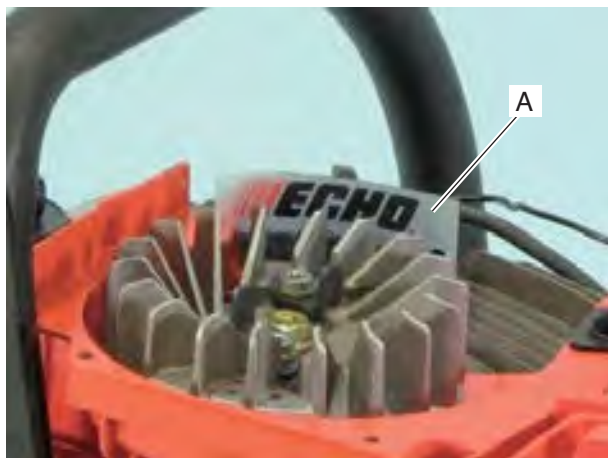

1. Insert Module air gap gauge: 91004 (A) or 0.3 - 0.4 mm (0.012 - 0.016 in) thick feeler gauge between flywheel and ignition coil shoes.

2. Rotate flywheel until magnetic poles of flywheel face ignition coil shoes.

3. Hold ignition coil against flywheel and tighten the bolts to specified torque (Refer to "Service information 1-3 Torque limits"). After tightening bolts, remove Module air gap gauge: 91004 (A) (or feeler gauge).

**NOTE:** When air gap is too narrow, contact with flywheel may result. When the air gap is too wide, spark is weak.

## 3-10 Inspecting flywheel and key

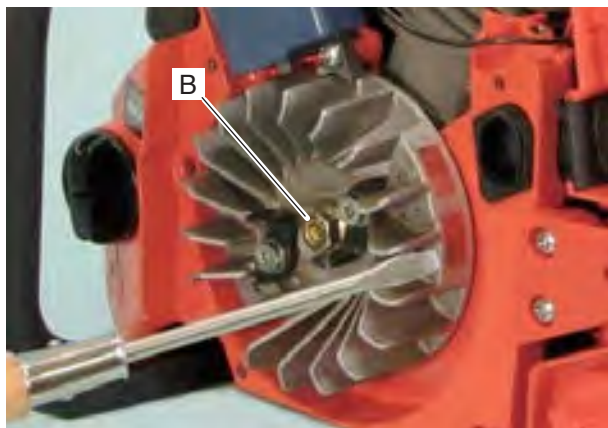

1. Inspect magnetic force of flywheel using flux meter, or bridging with a screwdriver as shown.

2. If magnetic force is weak, replace flywheel as follows.

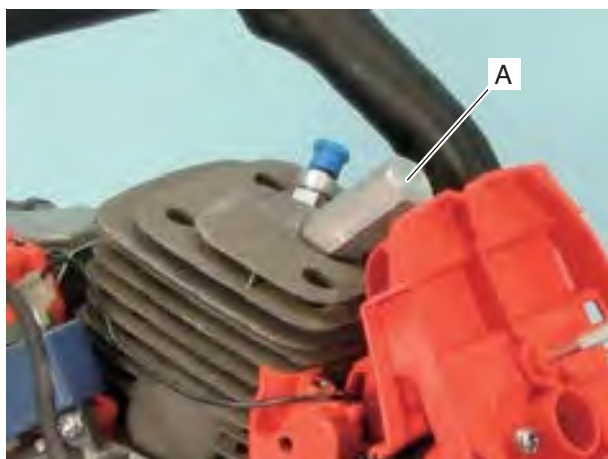

3. Install piston stopper 897537-30130 (A) into spark plug hole by hand, to stop crankshaft rotation.

**NOTE:** Do not use power tool to remove nut (B). Otherwise, piston damage may occur.

4. Remove nut (B) by rotating counterclockwise.

## 3-10 Inspecting flywheel and key (continued)

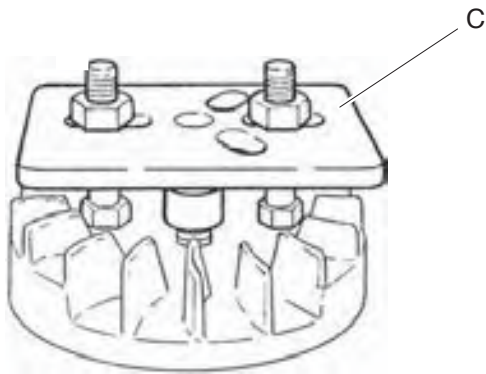

5. Remove starter pawls. Then set puller 897501-03938 (C) on flywheel as shown.

6. Tighten two nuts on the puller alternately to remove flywheel.

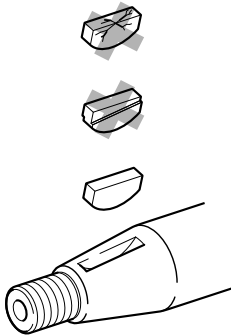

7. Inspect woodruff key for damage or shearing. Replace as required.

8. Wipe off oil from taper part of crankshaft before assembling flywheel.

9. Install woodruff key into key groove.

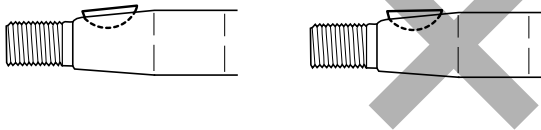

10. Reinstall starter pawls (Refer to "2-4 Replacing starter pawl").

11. Align flywheel key groove with woodruff key on crankshaft. Install flywheel and fasten flywheel nut clockwise.



4 FUEL SYSTEM

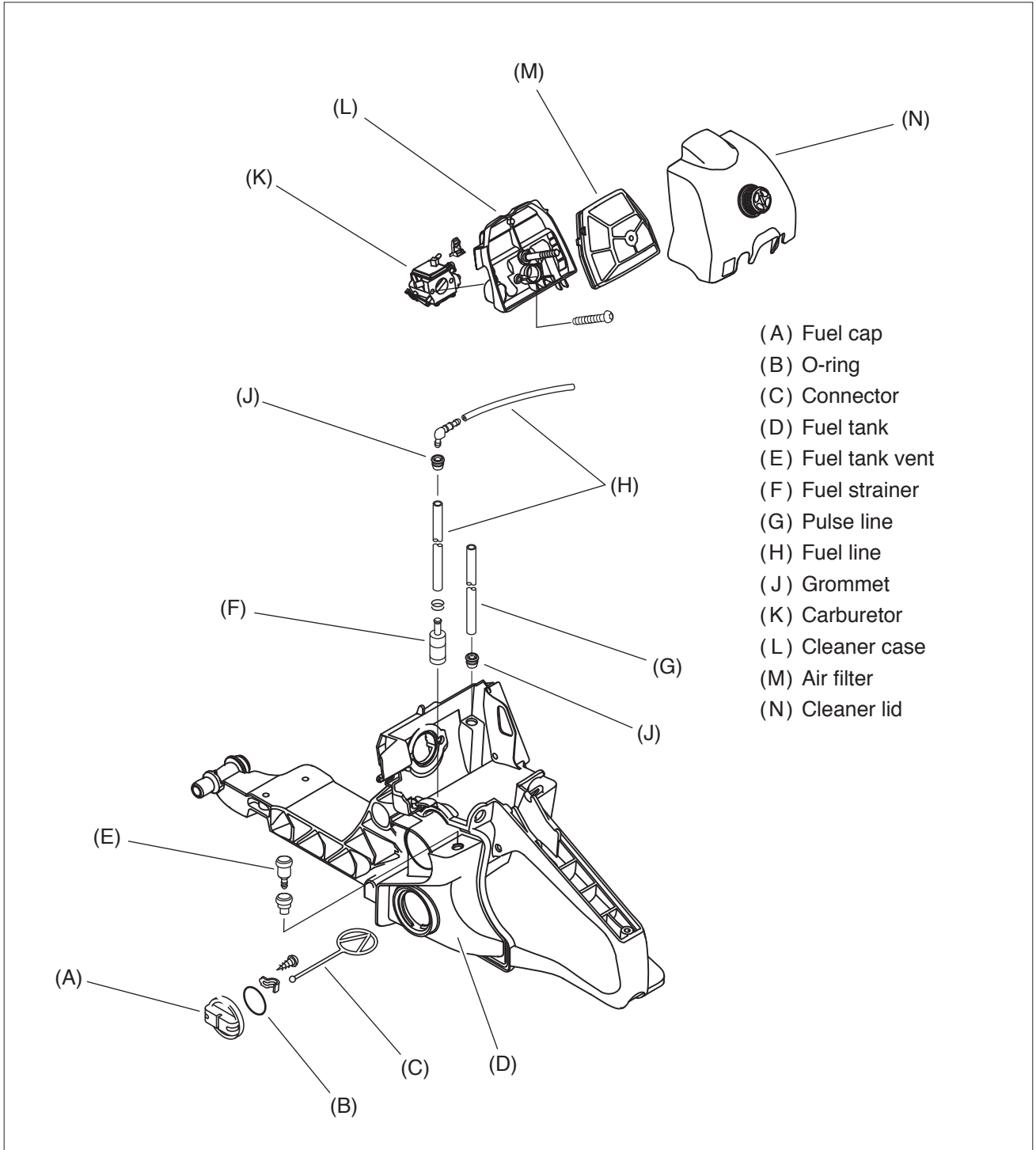

## 4-1 Inspecting air filter



1. Close choke shutter. Remove cleaner lid and air filter.
2. Inspect the surface of air filter. If blocked with dirt or dust, remove the obstruction using brush.

**WARNING**  **DANGER**

**Wear eye protection when working with compressed air. Eye damage can occur from flying particles.**

3. If heavily blocked with dirt or dust, clean air filter with compressed air.
4. Replace air filter with new one if heavily soiled or damaged.

## 4-2 Inspecting fuel cap and fuel strainer

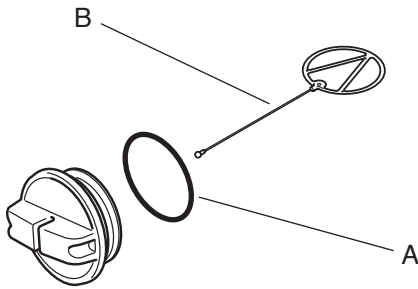

1. Remove fuel cap.
2. Inspect fuel cap for cracks and O-ring (A) for cuts or damage, and replace with new one as required.
3. Replace connector (B) if damaged.

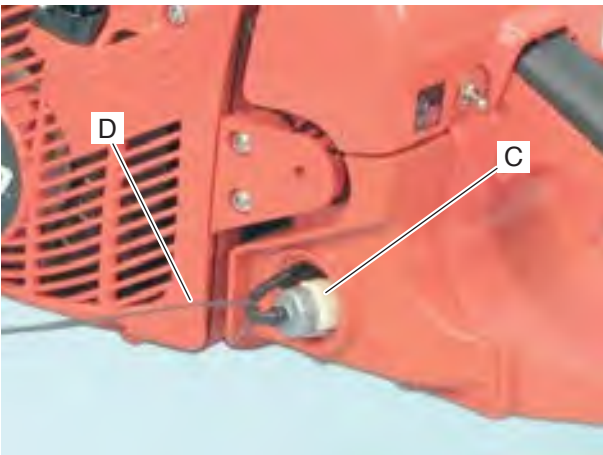

4. Pull fuel strainer (C) from fuel tank using a wire hook (D). Clean fuel strainer. Replace if defective or heavily soiled.
5. Reinstall fuel cap.

## 4-3 Inspecting fuel tank and line

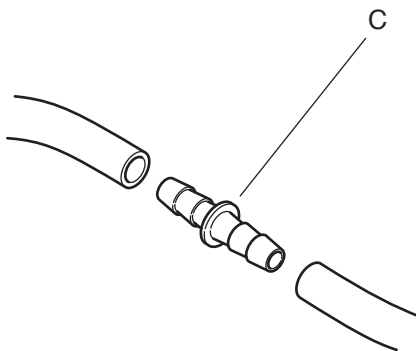
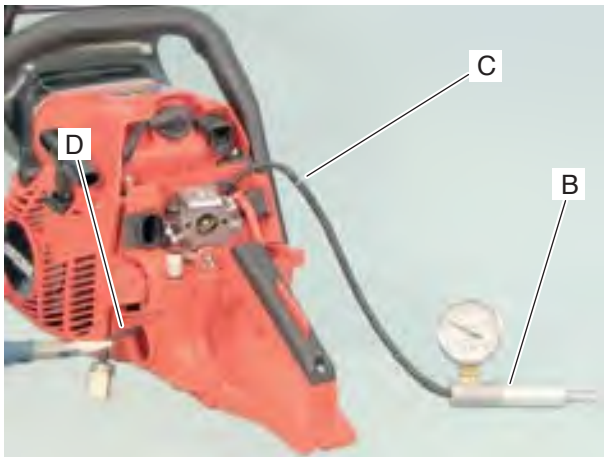
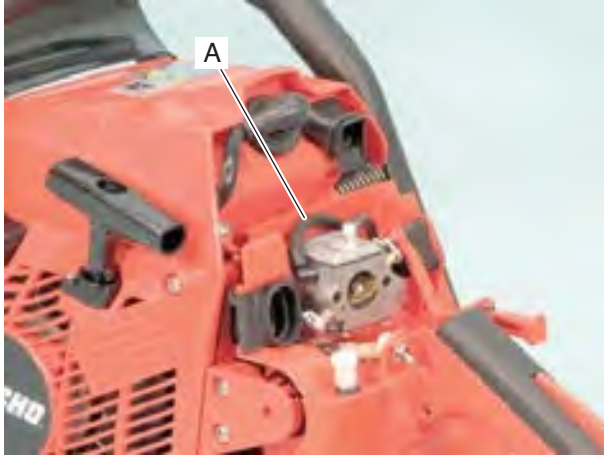

1. Clean fuel tank inside as required.
2. Remove cleaner lid, air filter and cleaner case.
3. Disconnect fuel line (A) from carburetor.

4. Connect pressure tester 897803-30133 (B) to fuel line.

**NOTE:** To connect pressure tester to fuel line, it is recommended to use pipe joint V186-000020 (C).

5. Remove fuel cap and pull out fuel strainer from fuel tank.

6. Pinch fuel line (D) with longnose pliers as shown.

**NOTE:** Wrap the ends of longnose pliers with tape (or cover with soft pipes) to protect fuel line from damage.

7. Apply pressure approx. 49 kPa (0.5 kgf/cm<sup>2</sup>) (7 psi).

8. If pressure drops, replace fuel line.

9. Put fuel strainer in fuel tank and fasten fuel cap securely.

10. Apply pressure approx. 9.8kPa (0.1 kgf/cm<sup>2</sup>) (1.4 psi).

11. Pressure should not drop. If pressure drops, leakage may occur from fuel cap, fuel cap O-ring, mating surface of fuel tank on rear handle, grommet, or tank vent. Inspect and replace defective part(s) with new one.

12. Remove pressure tester and connect fuel line to carburetor.

## 4-4 Inspecting and replacing tank vent

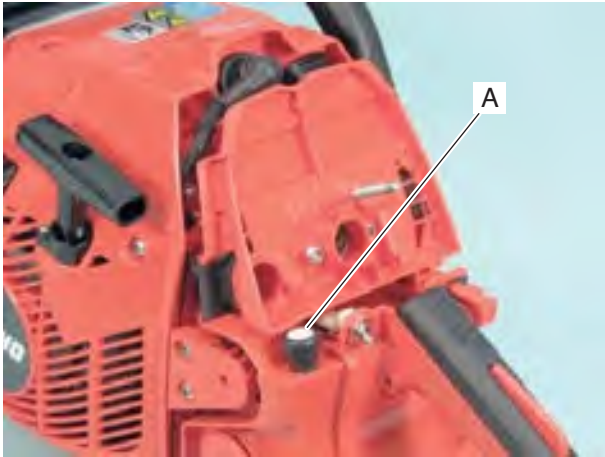

**NOTE:** Tank vent prevents a vacuum from forming in fuel tank when fuel in fuel tank is being consumed. When pressure in fuel tank becomes too high, tank vent releases the pressure.

1. Remove cleaner lid and air filter. Remove tank vent (A) from fuel tank and connect pressure tester 91024 (B).

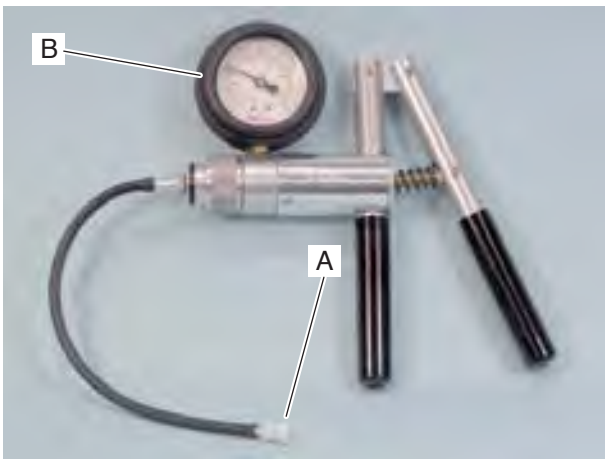

2. Apply pressure approx. 49 kPa (0.5 kgf/cm<sup>2</sup>) (7 psi). Make sure pressure is stable in range of 9.8 - 39.2 kPa (0.1 - 0.4 kgf/cm<sup>2</sup>) (1.4 - 5.7 psi).

3. If it is not in the range, gently clean tank vent with compressed air or replace with new one.

**NOTE:** Do not disassemble valves in tank vent assembly. Damage to valves will occur.

4. Apply negative pressure 19.6 kPa (0.2 kgf/cm<sup>2</sup>) (3 psi).

5. Tank vent should pass air freely without holding any pressure. If it does not, replace tank vent with new one.

## 4-4 Inspecting and replacing tank vent (continued)

**NOTE: Inspection using 897803-30133**

If pressure tester 91024 is not available, tank vent can be inspected with pressure tester 897803-30133 as follows.

1. Connect tank vent (A) to pressure tester 897803-30133 (B).
2. Apply pressure approx. 49 kPa (0.5 kgf/cm<sup>2</sup>) (7 psi), make sure pressure is stable in range of 9.8 - 39.2 kPa (0.1 - 0.4 kgf/cm<sup>2</sup>) (1.4 - 5.7 psi).
3. If it is not in the range, gently clean tank vent with compressed air or replace with new one.

**NOTE: Do not disassemble valves in tank vent assembly. Damage to valves will occur.**

4. Remove cap (C) of tank vent, and clean sponge (D).
5. Cut pipe 363011-00210 (E: 7x11x170mm) and 382011-01110 (F: 9x13x350) in approx. 30mm (1 1/4 in) length, and connect them to pressure tester as shown. Connect tank vent (A) without cap to pipe as shown.
6. Plug hole (a) with finger and apply pressure 19.6 kPa (0.2 kgf/cm<sup>2</sup>) (3 psi). The pressure should hold steady.
7. Remove finger from hole (a). Tank vent should pass air freely without holding any pressure. If it does not, replace tank vent with new one.

## 4-5 Replacing fuel line

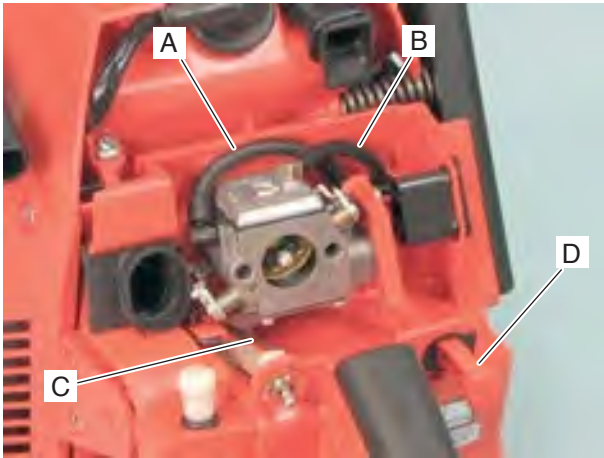

1. Remove cleaner lid, air filter and cleaner case.
2. Disconnect fuel line (A) and pulse line (B) from carburetor.
3. Remove carburetor by disconnecting throttle rod (C) and choke knob (D).

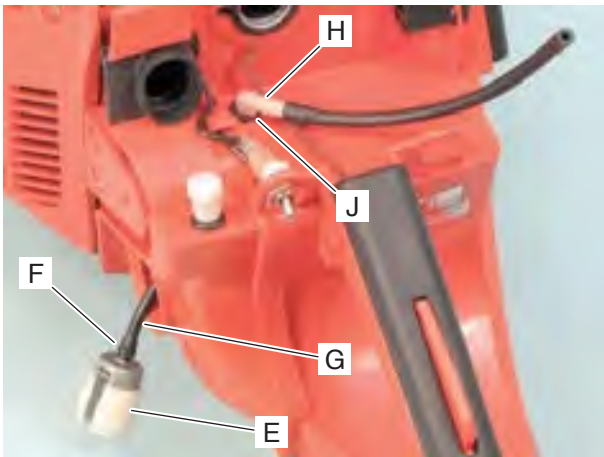

4. Remove fuel cap and remove fuel strainer (E) and clip (F) from fuel line (G).
5. Remove fuel line connector (H) from grommet (J) together with fuel lines. Replace them if defective.

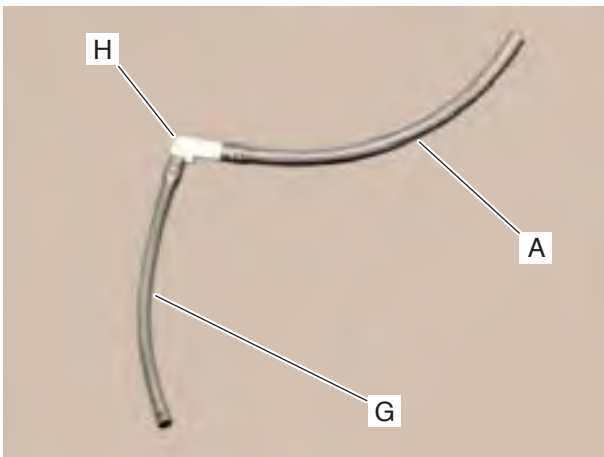

6. Assemble new lines (A: 135mm) and (G: 120mm) on fuel line connector (H). Pass fuel line (G) through grommet. Push fuel connector into grommet.
7. Pull out fuel line from fuel tank and install clip and fuel strainer to fuel line.
8. Reinstall carburetor, cleaner case, air filter and cleaner lid.

## 4-6 Adjusting carburetor

### 4-6-1 General adjusting rules

A. Before adjustment, check the following items.

1. The correct spark plug must be clean and properly gapped.
2. The air filter element must be clean and properly installed.
3. The muffler exhaust port must be clear of carbon.
4. The fuel lines, tank vent and fuel filter are in good condition and clear of debris.
5. The fuel is fresh ( > 89 octane :  $\frac{RON+MON}{2}$  ) and properly mixed at 50 : 1 with "ISO L-EGD" or "JASO M345-FC/FD" 2-stroke oil.
6. The recommended bar and chain must be installed, and properly tensioned.

**NOTE:** In order to achieve proper carburetor adjustment, a 20 (except 16) or 24 inch bar and chain should be installed on the unit.

B. Adjustment with limiter caps on carburetor: Set L and H mixture needles fully counterclockwise. Start and run engine for two minutes alternating engine speed between WOT for 5 seconds and idle for 5 seconds. Adjust idle speed screw to 2,800 +/- 150 rpm. Adjust H mixture needle to 12,500 +/- 300 rpm. If engine does not run correctly after this adjustment, proceed to the next step 4-6-2.

**IMPORTANT:** After adjusting carburetor according to the steps 4-6-2 and 4-6-3, the limiter cap(s) must be installed on L and H mixture needle(s) to comply with Emission Regulations.

### 4-6-2 Presetting idle adjust screw, L mixture needle and H mixture needle



Tools Required: Small screwdriver with 2.5 mm blade, electronic tachometer P/N G310-000050, limiter cap removal tool with 2.5 mm left-hand thread P/N 89801. Parts Required: (2) limiter caps P/N P003-000010.

1. Turn L and H mixture needles counterclockwise to rich side stop to align limiter cap tab (A) with locating slot (B), using 2.5 mm blade screwdriver.

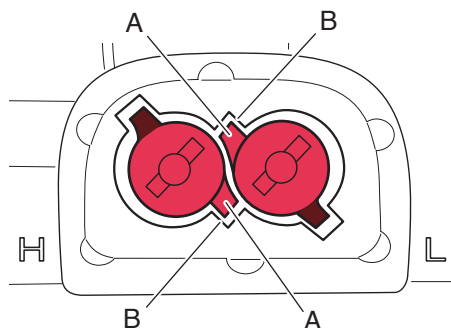

**NOTE:** If cap tabs (A) are misaligned with locating slots (B), the cap cannot be removed and the center hole threads will strip. If center hole threads strip, use 3 mm limiter cap removal tool P/N 89802 to remove limiter cap.

## 4-6 Adjusting carburetor (continued)

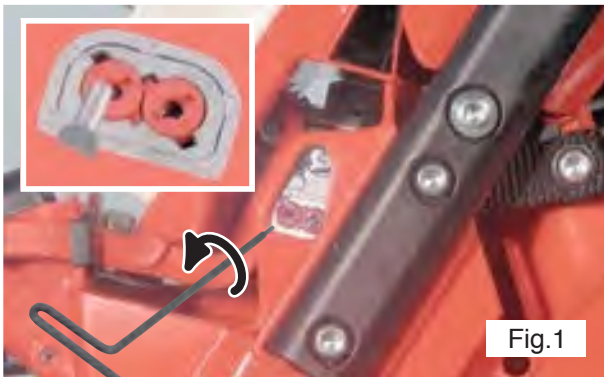

Fig.1



Fig.2



Fig.3



Fig.4

2. Screw 2.5 mm limiter cap removal tool P/N 89801 counterclockwise into center hole of either limiter cap until tab of the limiter cap just comes out of the locating slot (Fig.1, Fig.2).

**NOTE:** DO NOT COMPLETELY REMOVE LIMITER CAP FROM CARBURETOR!

If the first limiter cap is removed completely, the second limiter cap can be misaligned while inserting the cap removal tool.

3. Remove the limiter cap removal tool from the limiter cap by turning the tool clockwise, leaving the limiter cap in place (Fig.2).

4. Screw 2.5 mm limiter cap removal tool P/N 89801 counterclockwise into center hole of remaining limiter cap until the limiter cap is removed from the mixture needle completely (Fig.3). Remove the limiter cap from limiter cap removal tool by turning clockwise, then screw limiter cap removal tool into center hole of previous limiter cap to remove completely.

5. With 2.5 mm blade screwdriver, turn L and H mixture needles clockwise until lightly seated (Fig.4), then turn out both mixture needles following turns.

L mixture needle : 2, H mixture needle : 3/4

**NOTE:** If needles are forced during seating, damage to carburetor may occur.

6. Remove air cleaner lid and air filter to expose idle adjust screw and throttle plate. Turn idle adjust screw counterclockwise and set the screw until the tip just contacts the throttle plate. Then turn idle adjust screw 2 3/8 turns clockwise. Reinstall air filter, and cleaner lid.

**NOTE:** The initial carburetor settings for idle adjust screw, L and H mixture needles are intended to start and run engine before final carburetor adjustments are made through this procedure. The actual number of turns needed for engine operation may vary.



## 4-6 Adjusting carburetor (continued)

## 4-6-3 Adjusting carburetor

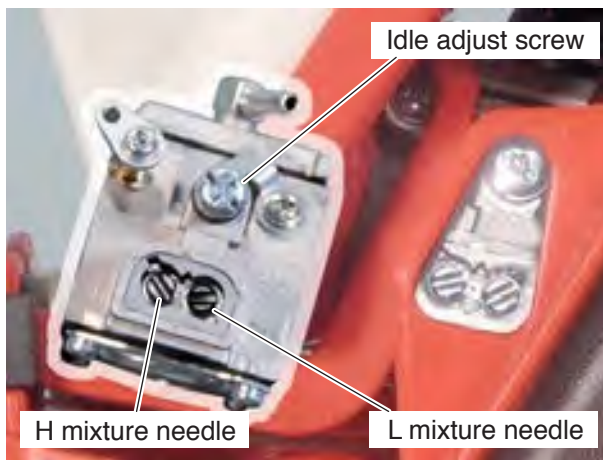

1. Start and warm engine for 1 minute alternating engine speed between WOT and idle every 5 seconds. Turn H mixture needle counterclockwise until engine speed drops to approx. 11,500 rpm at WOT.

**NOTE:** Do not run engine at high speed without load longer than 10 seconds, or engine damage may occur.

2. Adjust L mixture needle using 2.5 mm blade screwdriver to reach maximum engine rpm just before lean rpm drop off.

3. Set idle speed to 3,600 rpm by turning idle adjust screw. Engine rpm should be stable at 3,600 +/- 50 rpm after idle adjust screw adjustment.

4. Turn L mixture needle counterclockwise reducing idle speed 800 rpm to set idle speed at 2,800 rpm. The idle speed range is 2,700 - 2,900 rpm.

**NOTE:** Engine speed must be allowed to stabilize a minimum of 20 seconds after each adjustment of L mixture needle to assure accurate tachometer readings.

5. Before adjustment, WOT engine speed should be 11,500 rpm or less. If rpm is higher, turn H mixture needle counterclockwise until 11,500 rpm is achieved. To make the final WOT engine speed adjustment, turn H mixture needle clockwise in 1/8 turn increments with the engine at idle. After each adjustment, accelerate to WOT, and check rpm. The final rpm should fall within 12,100 - 12,500 rpm at WOT.

**NOTE:** When H mixture needle is turned completely clockwise, the engine will continue to run. If engine speed at WOT is above 13,300 rpm, adjust H mixture needle counterclockwise and set maximum engine speed at less than 13,000 rpm.



6. After adjusting carburetor, screw new limiter cap counterclockwise on limiter cap removal tool (C) (P/N 89801) approx. 2 turns as shown. Align limiter cap tabs (A) with locating slots (B) in extended housing of carburetor and put limiter caps on L and H mixture needles respectively. Gently press caps onto L and H mixture needles (do not rock caps back and forth). Remove tool (C) then fully seat caps until flush with housing of carburetor using bar tool.

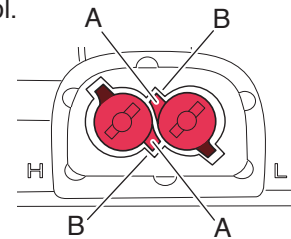

**IMPORTANT:** The limiter caps must be properly installed on L and H mixture needles to comply with Emission Regulations.

7. Start engine, and verify engine idle speed ranges from 2,600 to 3,200 rpm, and WOT engine speed ranges from 12,000 to 13,000 rpm. Make sure chain does not rotate when engine is idling. When final adjustment is completed, the engine should idle, accelerate smoothly, and attain WOT per above specification.

## 4-7 Air shutter



When it is cold weather and acceleration is poor, release air shutter.

1. Air shutter is located in cleaner case (A).



2. Picture shows normal position of air shutter (B).



rear view

3. Slide air shutter (B) to open air duct and introduce warm air from cylinder side to carburetor box.



**NOTE:** In order to avoid carburetor vapor lock, return air shutter to normal position when temperature is high enough.

## 4-8 Testing carburetor

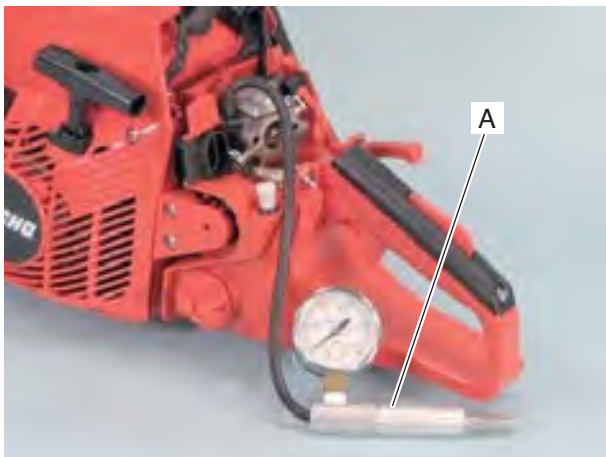

**NOTE:** To perform this test, carburetor interior should be wet with fuel. If dry, a little leakage may occur from diaphragms and/or inlet needle seat.

1. Remove cleaner lid, air filter and cleaner case. Disconnect fuel line from carburetor. Connect pressure tester 897803-30133 (A) to carburetor fuel inlet.

2. Apply pressure approx. 98 kPa (1 kgf/cm<sup>2</sup>) (14 psi).

3. If pressure remains steady, follow step 4 and 5. If pressure drops, proceed to step 6.

4. Pull starter grip. Pressure tester reading should drop and remain above 49 kPa (0.5 kgf/cm<sup>2</sup>) (7 psi).

5. If reading does not drop, inspect inlet needle valve for sticking or metering lever height is too low.

6. If pressure drops at step 2, or if pressure drops below standard figure at step 4, remove carburetor from the unit, disconnecting pulse line, throttle rod and choke knob.

7. Submerge carburetor in suitable clean solvent to locate the leak by applying pressure approx. 98 kPa (1 kgf/cm<sup>2</sup>) (14 psi).

8. If air bubbles come out between pump cover and carburetor body (B), inspect pump diaphragm, pump gasket, and diaphragm seat of carburetor body (Refer to "4-13 Inspecting diaphragm").

9. If air bubbles come out from throttle bore (C), inspect inlet valve, metering lever spring, and metering lever height (Refer to "4-11 Inspecting inlet needle valve").

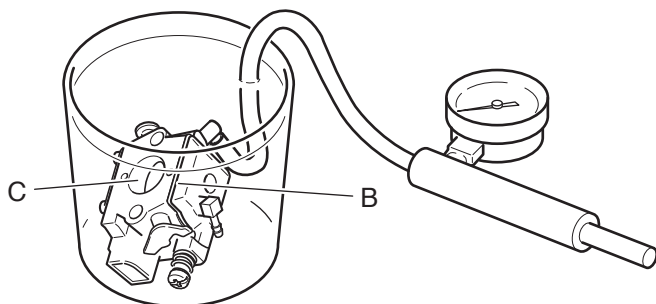

## 4-9 Inspecting crankcase pulse passage

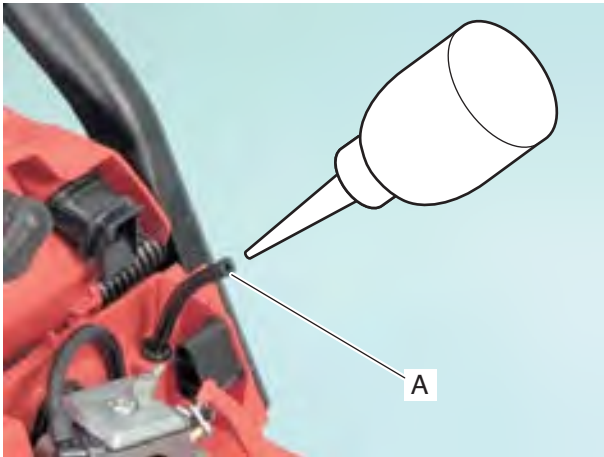

1. Drop a little oil in the end of pulse line (A) as shown.
2. Remove spark plug and pull starter grip several times. Oil should spit back from the hole.
3. If not, inspect whether pulse passage is clogged. Repair or replace as required.

## 4-10 Inspecting metering lever height

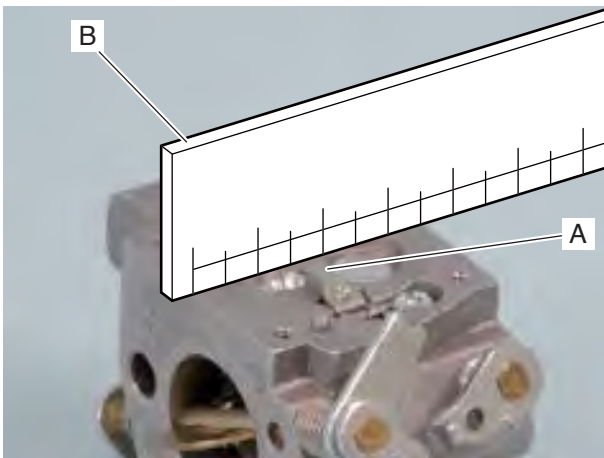

1. Remove carburetor.
2. Remove metering diaphragm cover, metering diaphragm and gasket.
3. Inspect metering lever (A) height using ruler (B). Metering lever height should be flush with diaphragm seat.
4. If necessary, gently bend metering lever up or down to set the metering lever to proper position.

**NOTE:** When metering lever is:

Too high → Fuel flooding occurs

Too low → Fuel starvation / overheating occurs

## 4-11 Inspecting inlet needle valve

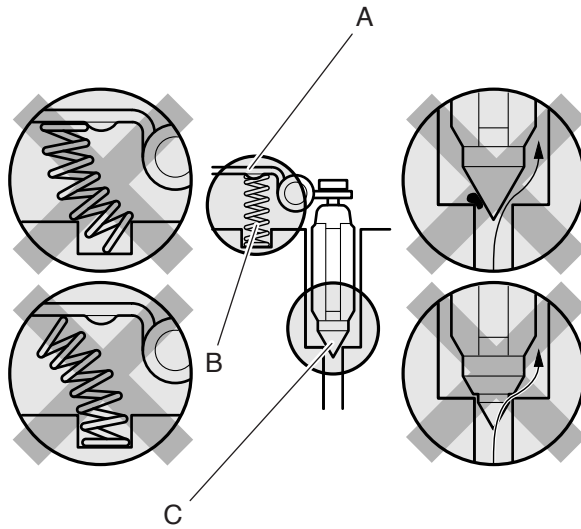

1. Remove metering lever (A) and pivot pin. Remove spring (B) and inlet needle valve (C).

2. Inspect inlet needle valve if worn or sticky. Clean or replace as required.

**NOTE:** Causes of fuel flooding from carburetor to cylinder are as follows:

- Improper assembling of metering lever and spring.
- Dirt between inlet needle valve and valve seat.
- Worn inlet needle valve tip.

3. Clean inlet needle valve seat using suitable clean solvent (do not use metal tools).

4. Reassemble inlet needle valve, spring, metering lever and pivot pin.

**NOTE:** Insure proper metering lever installation as follows.

- (1) Spring is seated in its hole at chamber floor.
- (2) Spring is under dimple of metering lever.
- (3) metering lever fork is holding inlet needle valve.

## 4-12 Inspecting diaphragm

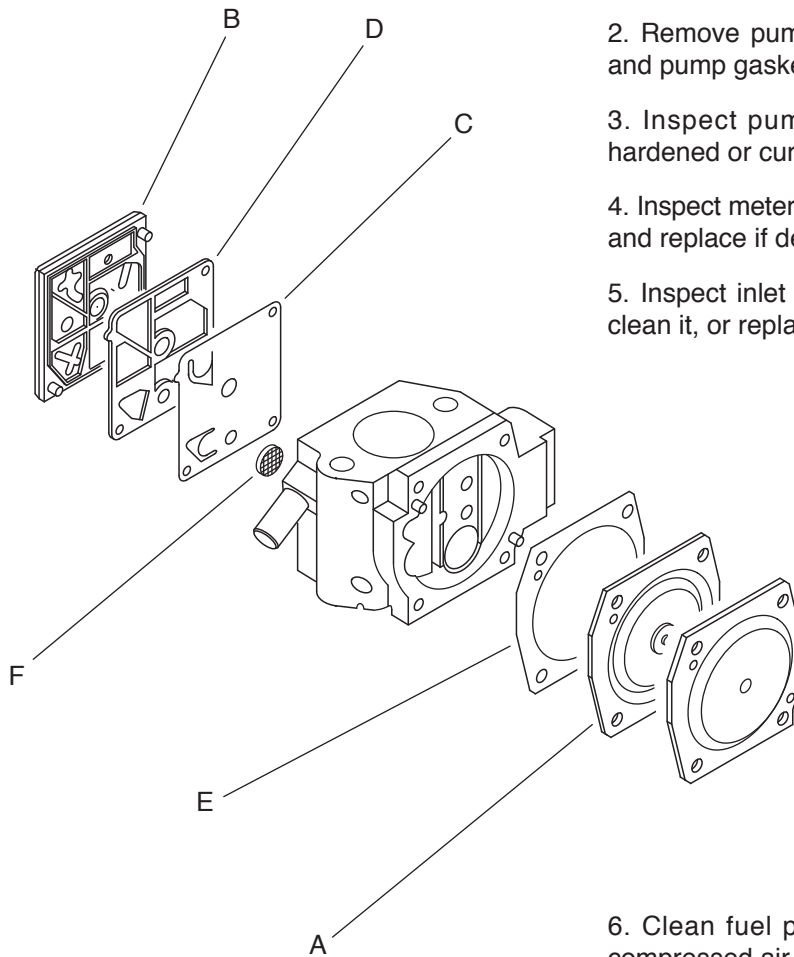

1. Inspect metering diaphragm (A) for hardening, distortion, or pin hole. Replace as required.

2. Remove pump cover (B), pump diaphragm (C) and pump gasket (D).

3. Inspect pump diaphragm (C) and replace if hardened or curled at valve tabs.

4. Inspect metering gasket (E) and pump gasket (D) and replace if defective.

5. Inspect inlet screen (F) if blocked, remove and clean it, or replace.

6. Clean fuel passages in carburetor body with compressed air.

**NOTE:** Before cleaning metering side with compressed air, turn "H" needle clockwise until lightly seated and remove inlet needle valve. Otherwise, main nozzle check valve and inlet needle valve spring may be damaged by the compressed air.

**NOTE:** When cleaning pump side with compressed air, take care not to blow inlet screen (F) away.

### 4-13 Replacing Welch plug

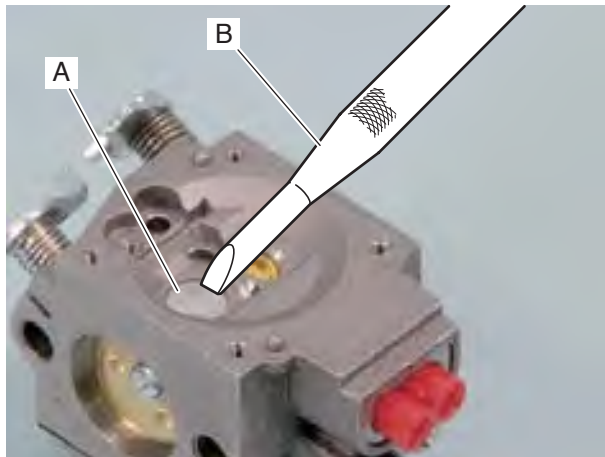

If engine does not run smoothly even after readjusting carburetor and inspecting carburetor parts, inspect low speed ports on carburetor as follows:

1. Remove metering lever and related parts to protect them from damage.
2. To remove Welch plug (A), punch the remover tool (B) through Welch plug at low angle and pry it out.

**NOTE:** Remover tool (B) and welch plug installer (C) are included in Welch plug tool kit (Part number: 500-500).

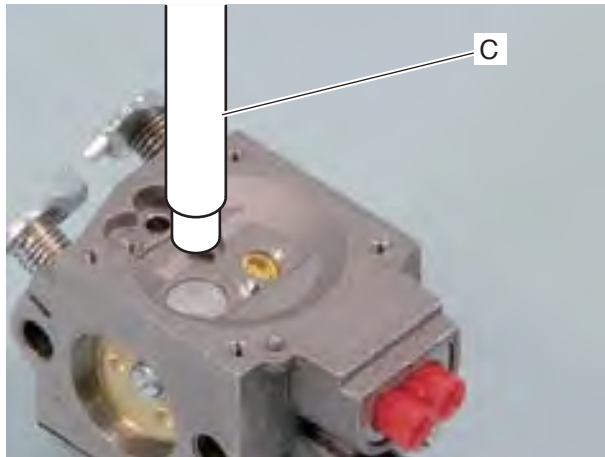

3. Clean low speed ports with compressed air.
4. Place a new Welch plug over the opening and gently tap it until flush using welch plug installer (C).
5. Install all removed parts to carburetor body.

## 4-14 Installing carburetor

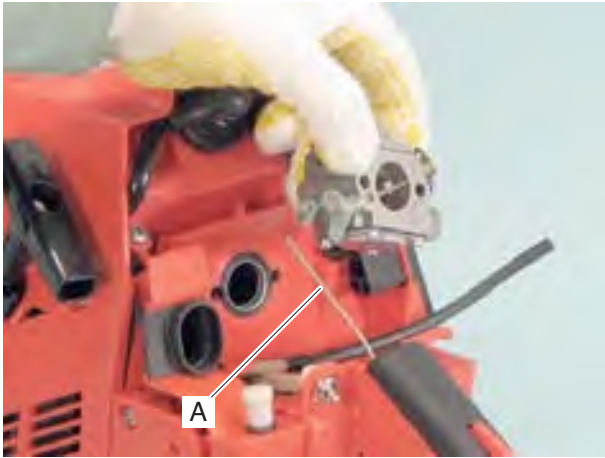

1. Connect throttle rod (A) to carburetor.

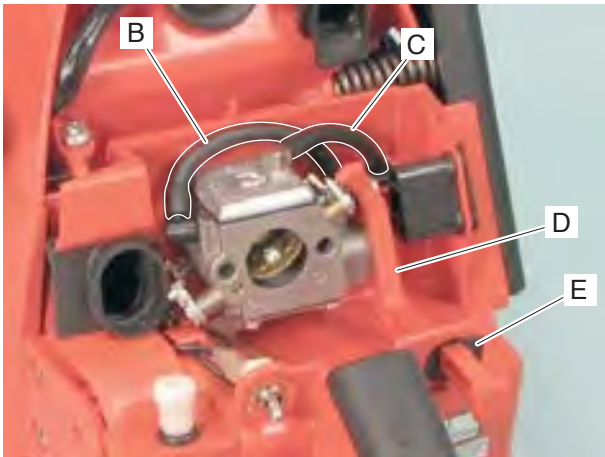

2. Connect fuel line (B) and pulse line (C) to carburetor as shown.

3. Connect choke rod (D) to carburetor. Install choke rod to rear handle, with choke grommet (E).

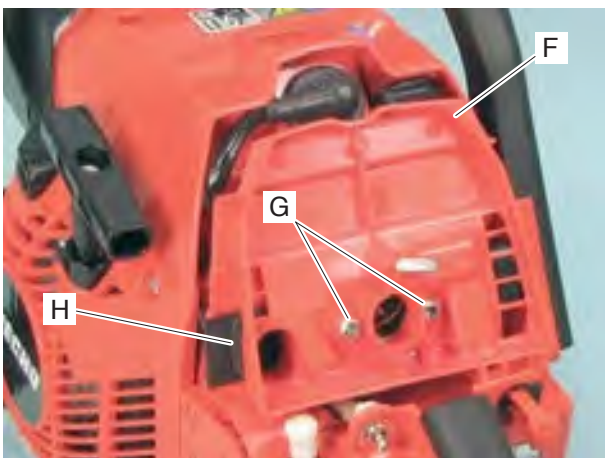

4. Secure carburetor and cleaner case (F) with two bolts (G). Assure intake pipe (H) engages correctly.



5 CLUTCH SYSTEM

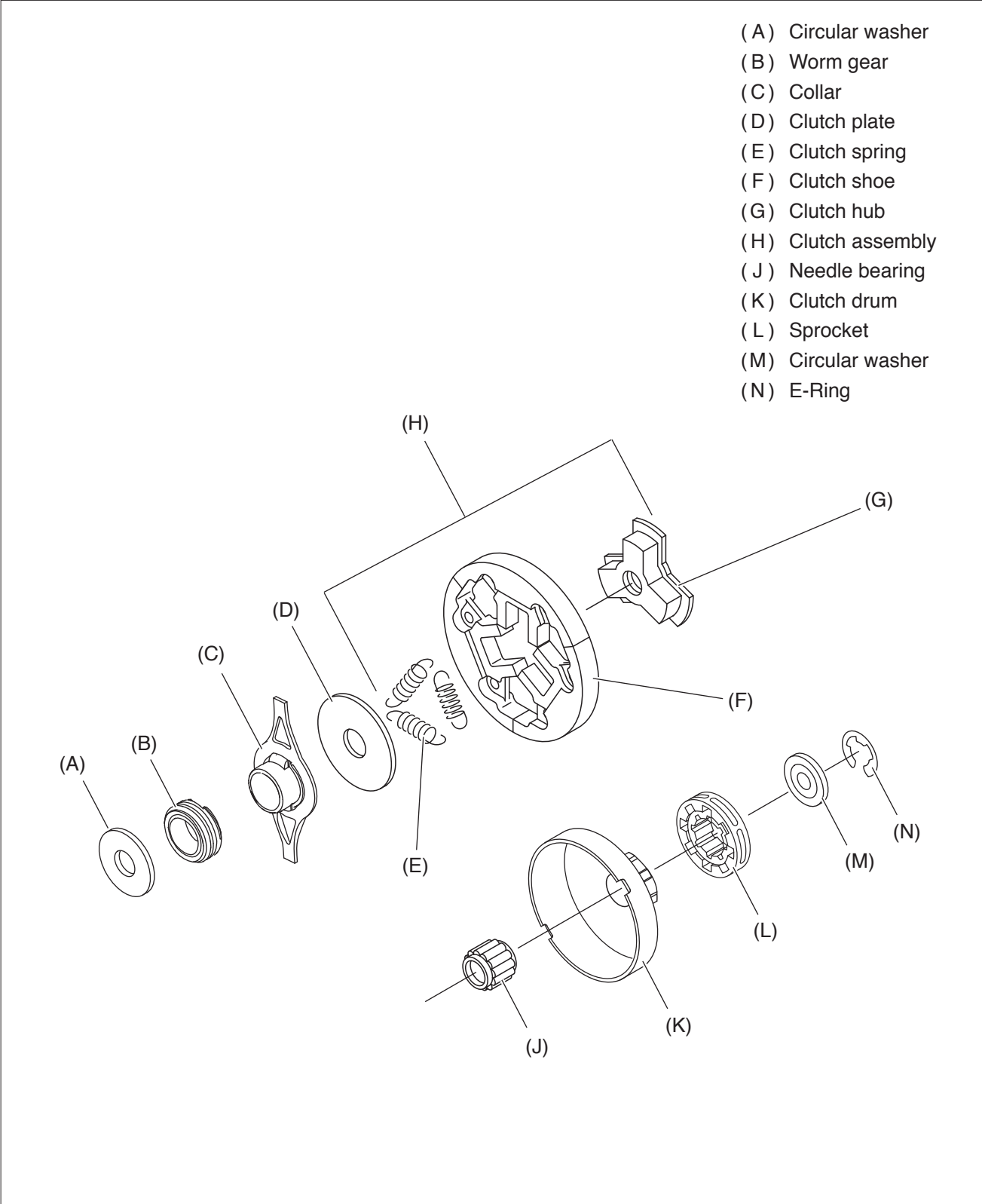

## 5-1 Inspecting clutch parts

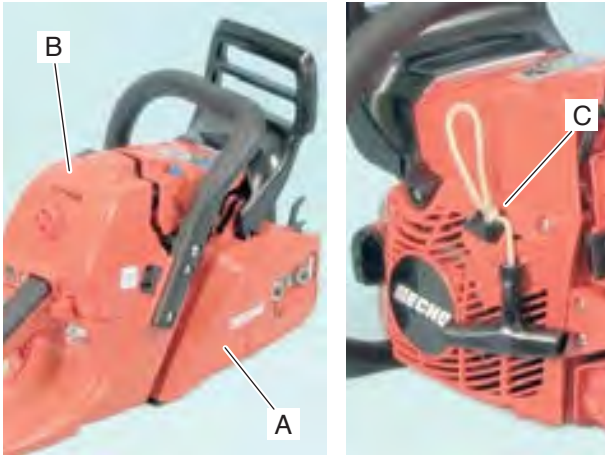

1. Remove sprocket guard (A), cleaner lid (B) and air filter.

**NOTE:** If starter assembly is installed, pull starter rope out about 20 cm (8 in), and make a temporary knot (C) to prevent starter damage when installing clutch assembly.

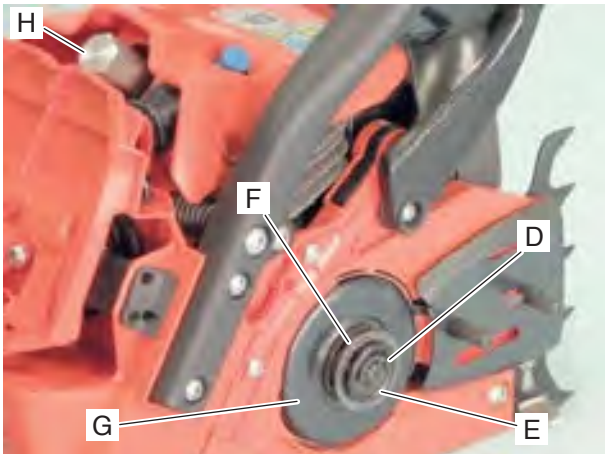

2. Remove E-ring (D), circular washer (E) and sprocket (F).

3. Remove clutch drum (G) with needle bearing inside.

4. Disconnect spark plug cap and remove spark plug.

5. Install piston stopper 897537-30130 (H) in spark plug hole to stop crankshaft rotation.

6. Rotate clutch assembly clockwise by hand until it cannot be rotated further.

7. Loosen clutch assembly (Left-hand thread) rotating clockwise with clutch tool 897505-16133 (J) and remove it.

**NOTE:** Do not use power tools. Otherwise, piston damage may occur.

8. Remove clutch plate, collar, worm gear and circular washer.

9. Inspect clutch shoes for wear and spring for weakness or damage. Replace clutch parts as required.

10. Inspect clutch drum and sprocket. Replace if deformed or worn out.

11. Inspect needle bearing, collar and worm gear for damage, discoloration or deformation. Replace as required.

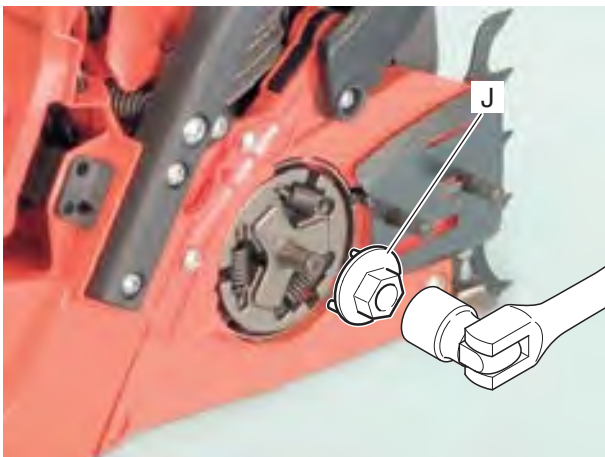

## 5-2 Replacing clutch parts

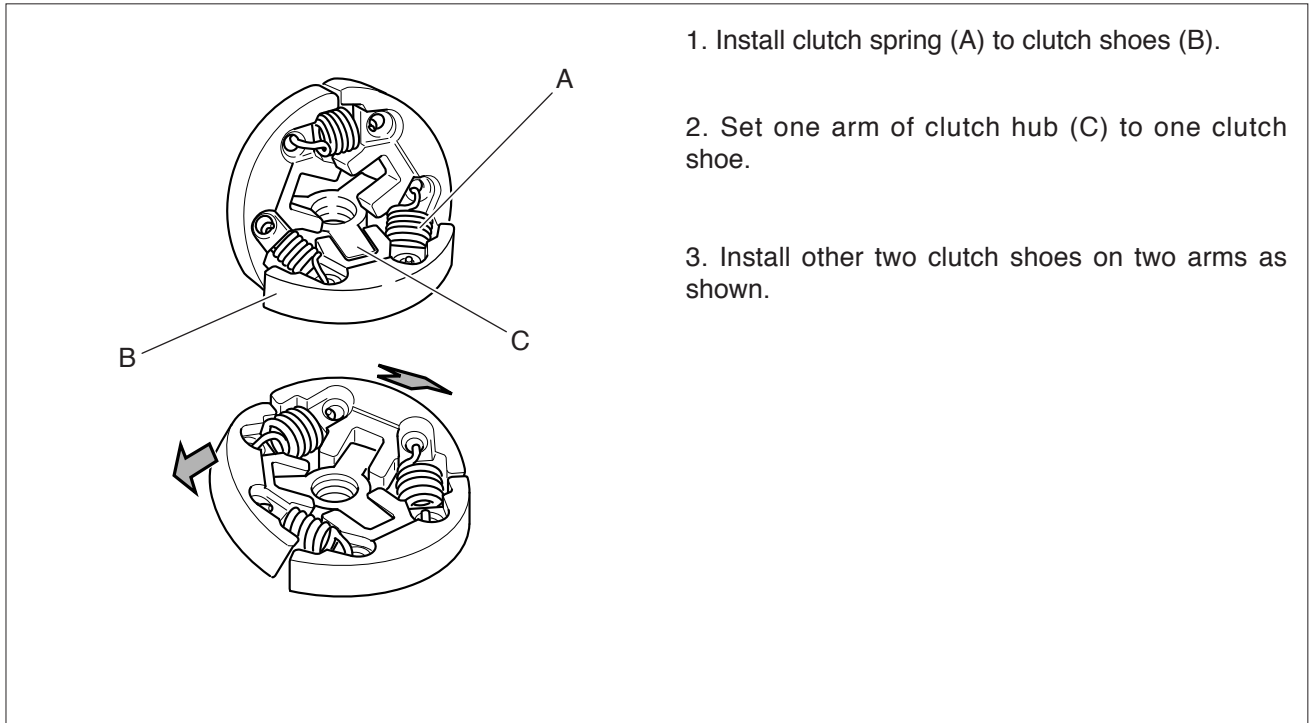

1. Install clutch spring (A) to clutch shoes (B).
2. Set one arm of clutch hub (C) to one clutch shoe.
3. Install other two clutch shoes on two arms as shown.

## 5-3 Installing clutch assembly

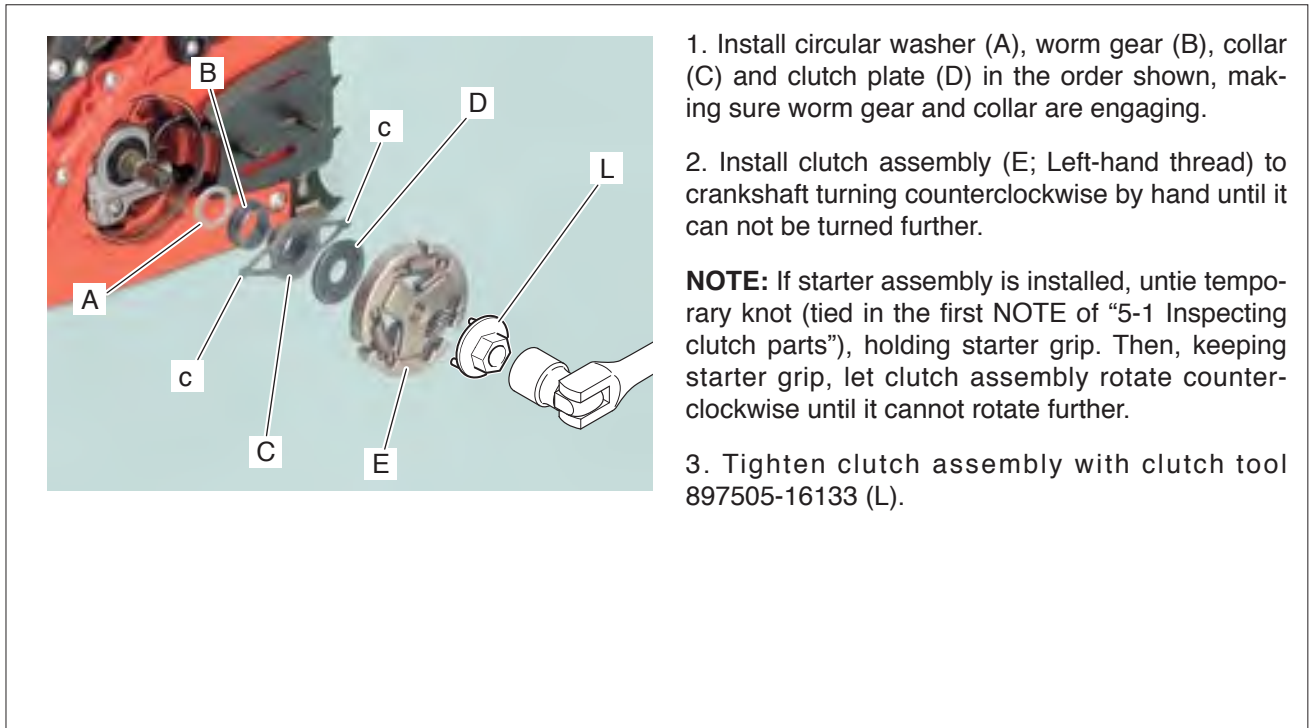

1. Install circular washer (A), worm gear (B), collar (C) and clutch plate (D) in the order shown, making sure worm gear and collar are engaging.

2. Install clutch assembly (E; Left-hand thread) to crankshaft turning counterclockwise by hand until it can not be turned further.

**NOTE:** If starter assembly is installed, untie temporary knot (tied in the first NOTE of "5-1 Inspecting clutch parts"), holding starter grip. Then, keeping starter grip, let clutch assembly rotate counterclockwise until it cannot rotate further.

3. Tighten clutch assembly with clutch tool 897505-16133 (L).

## 5-3 Installing clutch assembly (Continued)

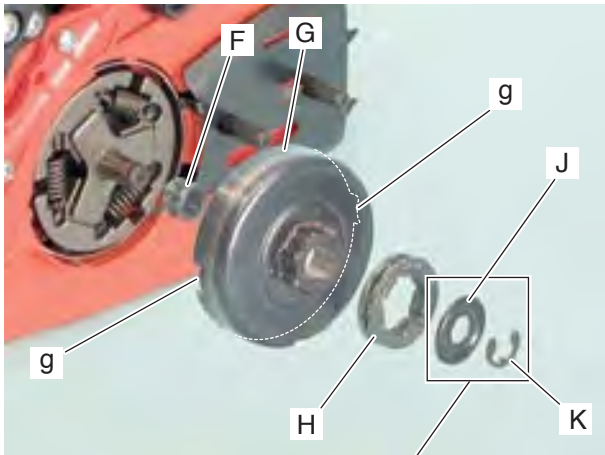

4. Apply lithium-based grease to needle bearing (F). Install clutch drum (G) and needle bearing (F) on crankshaft, placing the hands (c) of collar (C) in cutouts (g) of clutch drum.

5. Install sprocket (H). Install circular washer (J), facing flat side to sprocket (H).

6. Install new E-ring (K) with smooth side to washer (J). Use a new E-ring every time clutch assembly is installed on crankshaft.

7. Remove piston stopper and reinstall all removed parts.

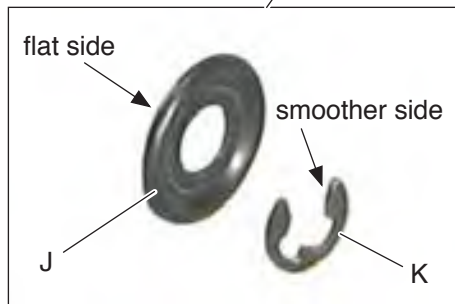

6 CHAIN BRAKE SYSTEM

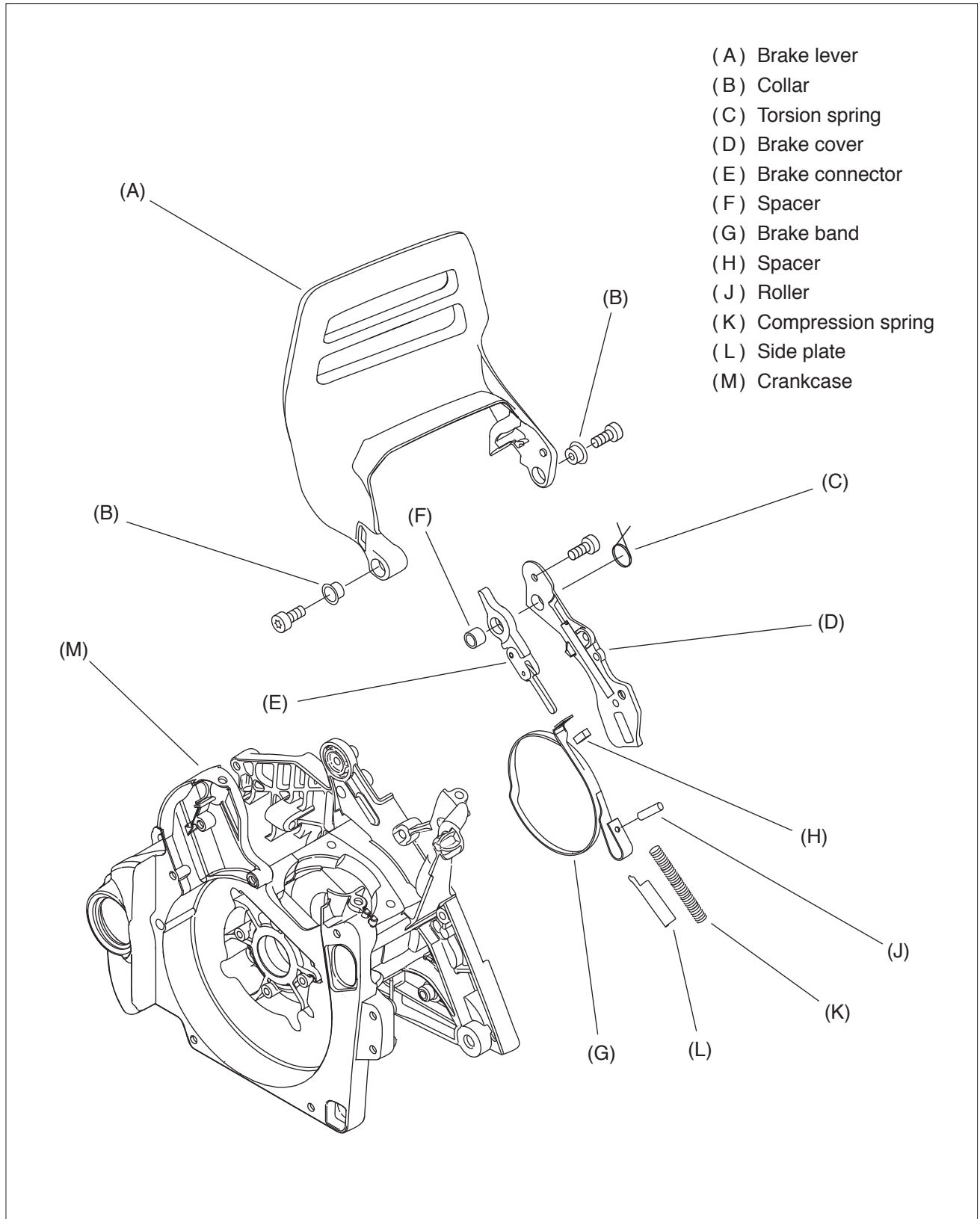

## 6-1 Disassembling chain brake

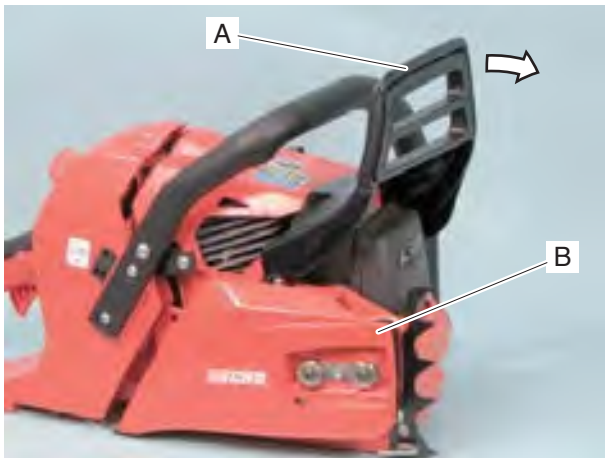
**WARNING**  **DANGER**

Wear eye protection and safety gloves when disassembling or assembling chain brake to protect eye and hand from injury.

1. Move brake lever (A) to chain brake engaging position.
2. Remove sprocket guard (B) and brake lever.

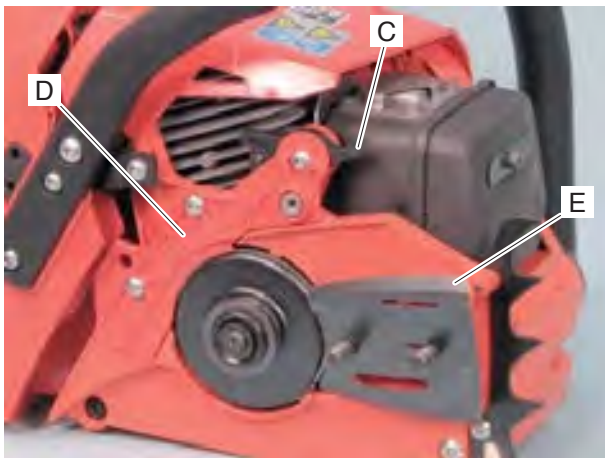

**NOTE:** Make sure that lever (C) is in engaging position before removing brake cover (D), otherwise compression spring may jump out.

3. Loosen three screws securing brake cover (D) and remove brake cover.
4. Remove guide plate (E).
5. Inspect all the brake parts for damage. Replace them as required.

6-2 Assembling brake parts

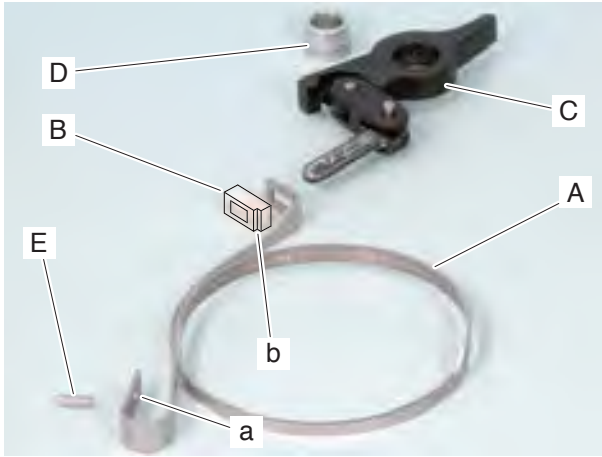

1. Set brake band (A) together with spacer (B), brake connector (C) and spacer (D), placing the notch (b) of spacer (B) as shown. Install roller (E) through brake band hole (a).

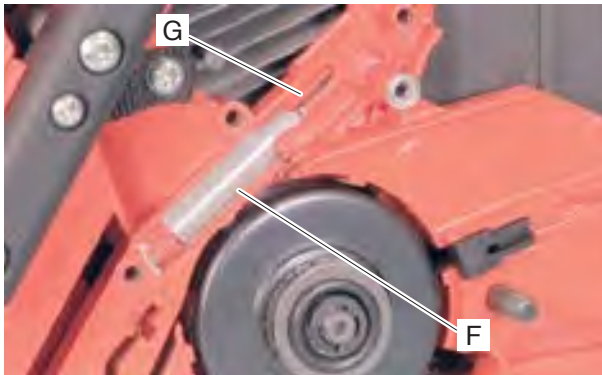

2. Set side plate (F) on crankcase groove as shown.

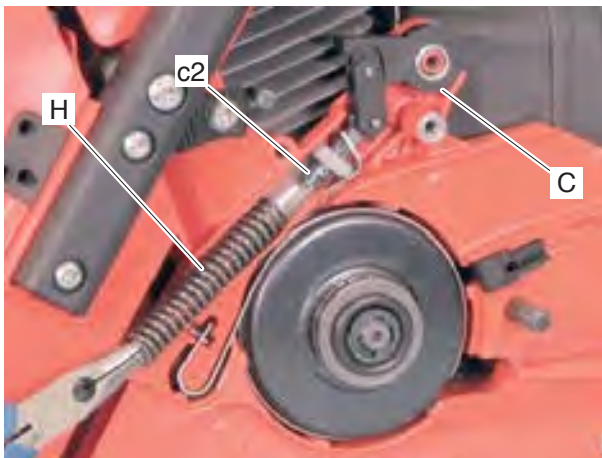

3. Install brake band and other parts (refer to the above 1.) on crankcase as shown. Make sure the pin (c1) of brake connector (C) is engaging with the groove (G) of crankcase.

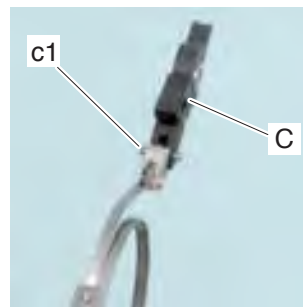

4. Slide in compression spring (H) to the end (c2) of brake connector as shown.

5. Install compression spring (H) in crankcase, by pushing with longnose pliers etc. as shown.

6. Apply molybdenum grease on entire of compression spring and other friction parts.

7. Reinstall guide plate, brake cover and other parts.

## 7 SAW CHAIN LUBRICATION SYSTEM

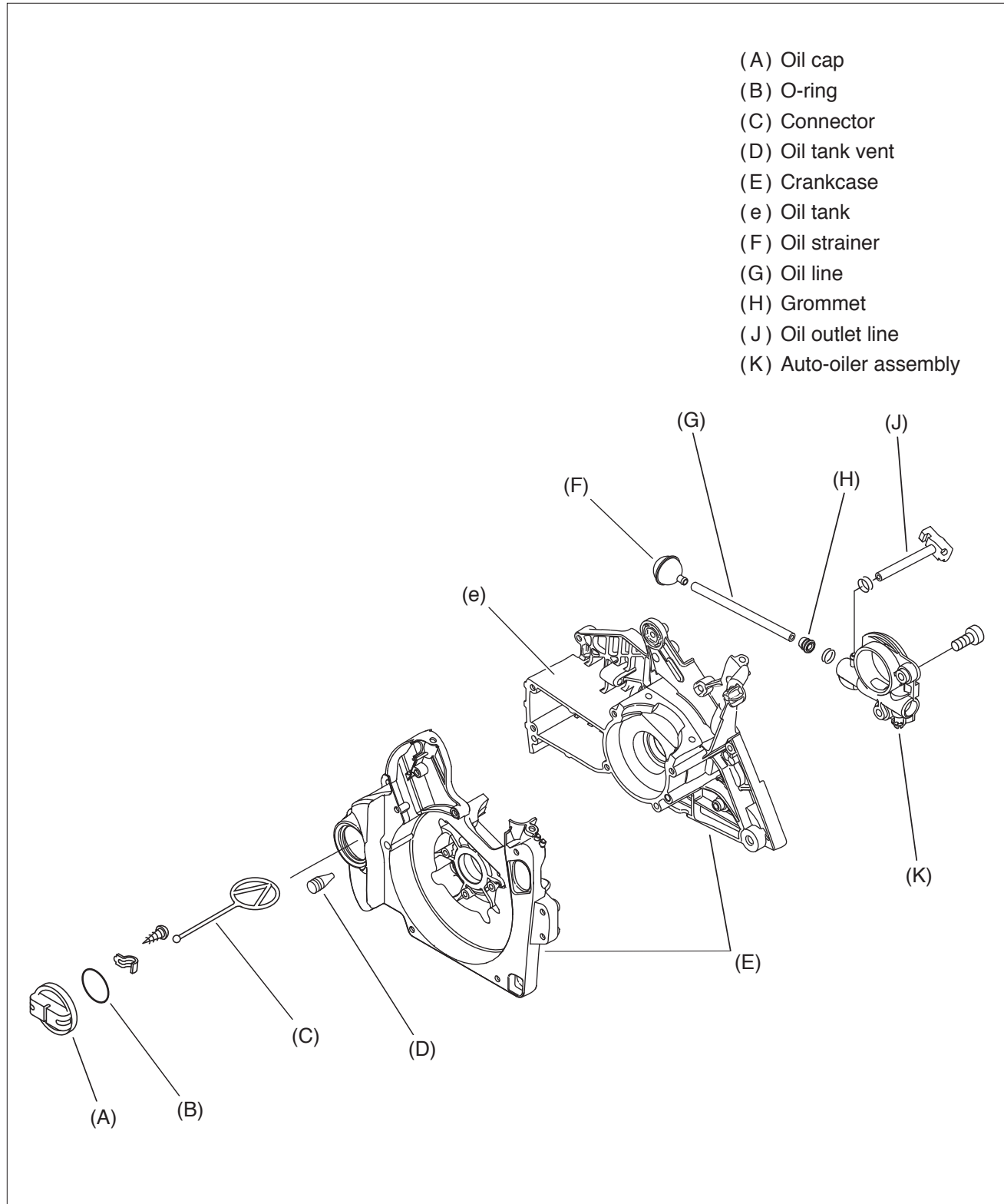



## 7-1 Inspecting oil cap and strainer

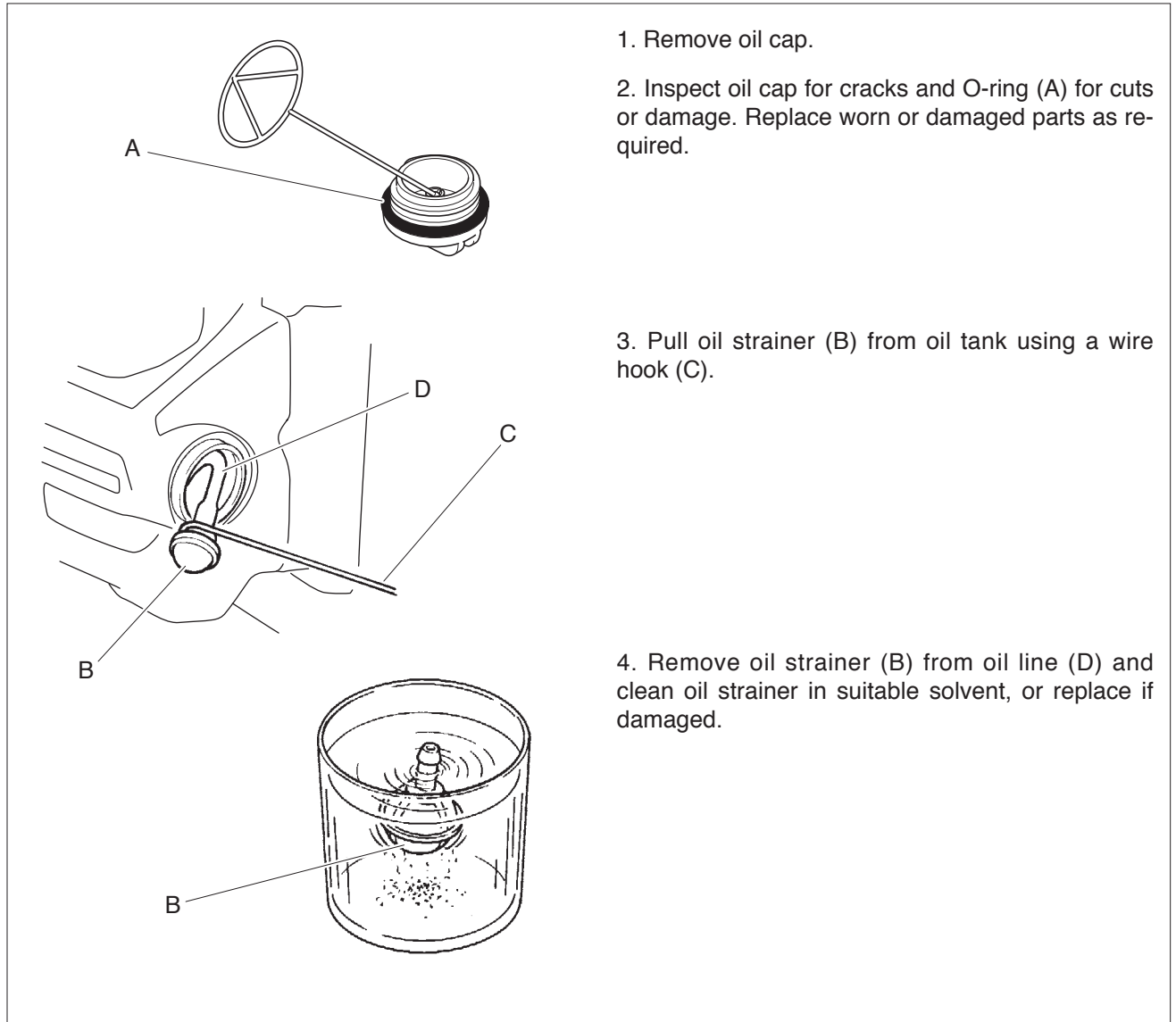

## 7-2 Inspecting auto-oiler assembly and oil line

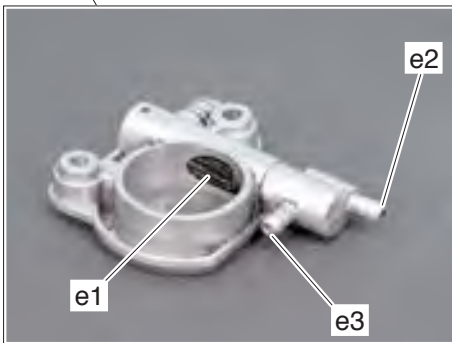
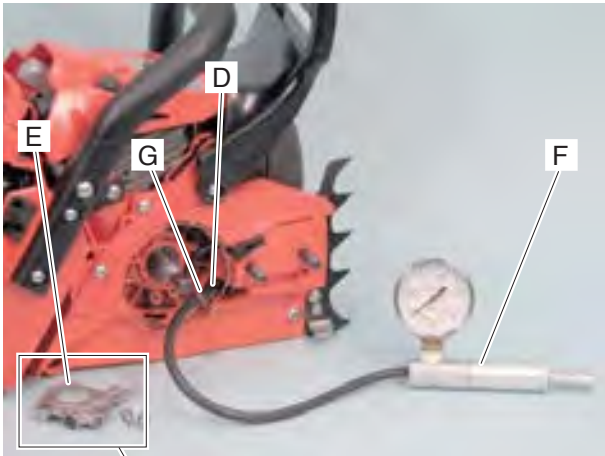
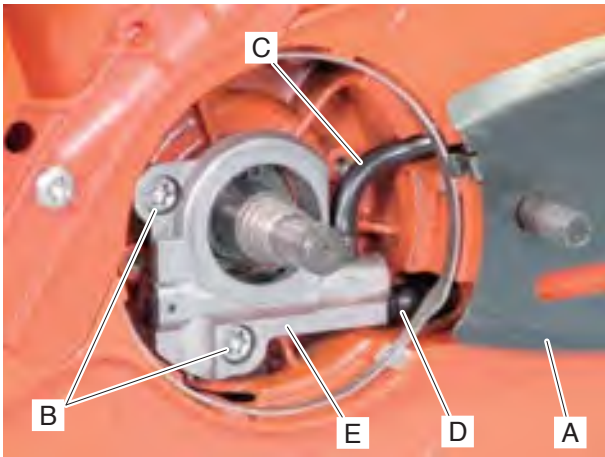

1. Referring to “5-1 Inspecting clutch parts”, remove clutch parts.

2. Remove inner guide plate (A).

3. Remove two bolts (B).

4. Disconnect oil outlet line (C) and oil line (D) from auto-oiler assembly (E), and remove auto-oiler assembly.

5. Inspect auto-oiler assembly (E) for discoloration or deformation. Inspect gear (e1) for wear and damage. Inspect oil inlet (e2) and outlet (e3) for clog. Replace as required.

6. Connect pressure tester 897803-30133 (F) to oil line (D) with pipe joint V186-000020 (G).

7. Tighten oil cap and apply pressure approx. 9.8 kPa (0.1kgf/cm<sup>2</sup>) (1.4psi).

8. Pressure should not drop. If the pressure drops, leakage may occur at oil cap, oil cap O-ring, mating surface of oil tank, oil line, grommet, or oil tank vent. Inspect them and replace defective part(s) with new parts as required.

## 7-3 Inspecting oil tank vent

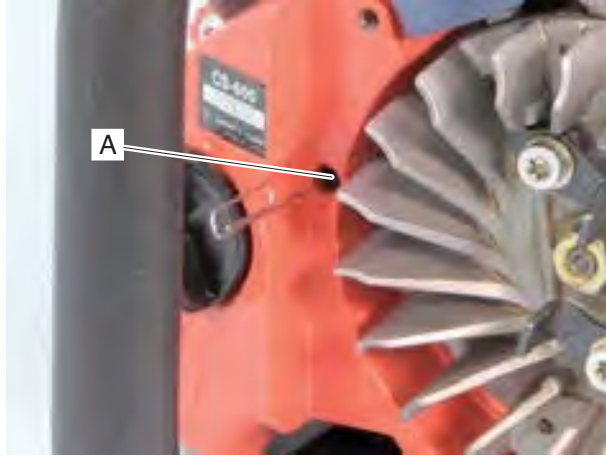

**NOTE:** Oil tank vent prevents a vacuum from forming in oil tank when chain oil in the tank is consumed.

1. Remove oil tank vent (A) using paper clip and clean it.

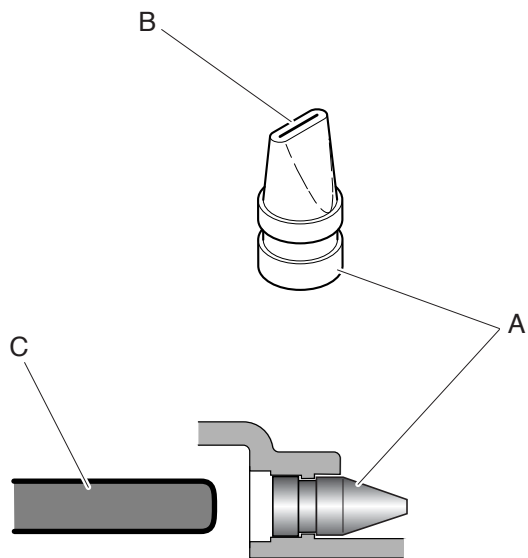

2. Check that oil tank vent lips (B) are not hard or deformed. Replace as required.

3. Install oil tank vent (A) using suitable tool (C) as shown.

## 7-4 Replacing oil line and grommet

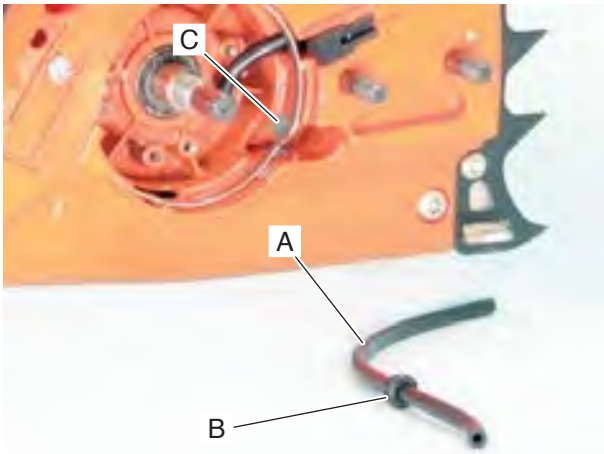

1. Pull out oil strainer from oil tank (Refer to “7-1 Inspecting oil cap and strainer”) and remove oil strainer from oil line.
2. Remove auto-oiler assembly from crankcase (Refer to “7-2 Inspecting auto-oiler assembly and oil line”).
3. Remove oil line with grommet, from crankcase.
4. Insert new oil line (A) to new grommet (B).
5. Assemble grommet (B) in grommet hole (C) of crankcase.

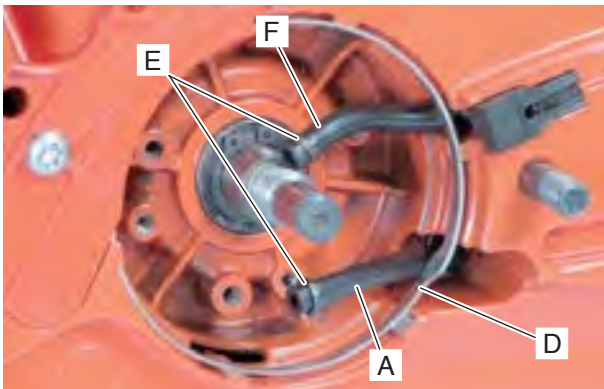

6. Pass oil line (A) under brake band (D) and set clips (E) on the end of oil line and oil outlet line (F).

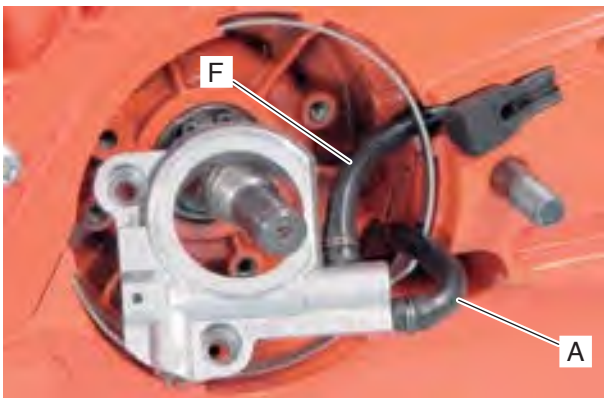

7. Connect oil line (A) and oil outlet line (F) to auto-oiler assembly as shown.

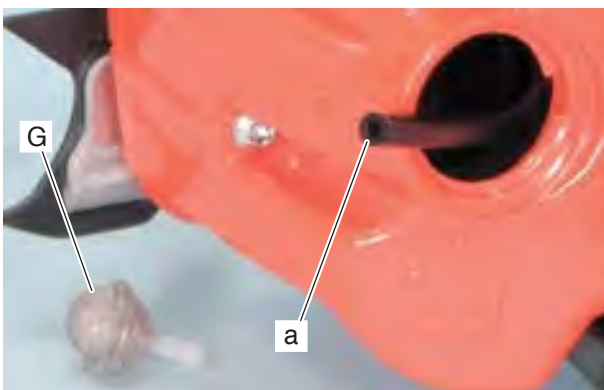

8. Pull out the other end (a) of oil line from oil cap hole.
9. Reinstall auto-oiler assembly to crankcase, adjusting oil line length by pulling the other end (a) of oil line.
10. Install oil strainer (G) to the other end (a) of oil line.
11. Put oil strainer and oil line in oil tank. Make sure oil strainer can move freely in oil tank.

**NOTE:** If oil strainer cannot move freely in oil tank, chain oil may not be supplied properly.

## 7-5 Disassembling auto-oiler assembly

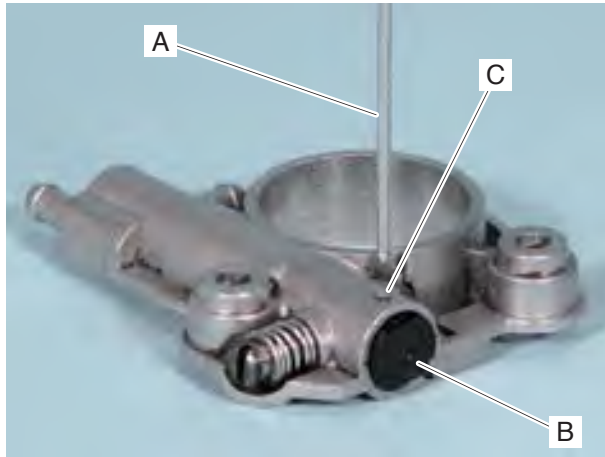

1. Remove auto-oiler assembly from the unit.
2. Using a tool of approx. 1.5 mm (0.06 in) dia. (A), push side wall of plug (B) through hole (C) to remove plug.

**NOTE:** Plug may suddenly spring out of auto-oiler assembly body.



3. Pull out spring pin (D) from adjuster needle (E) with pliers.
4. Pull out adjuster needle (E) from auto-oiler body.

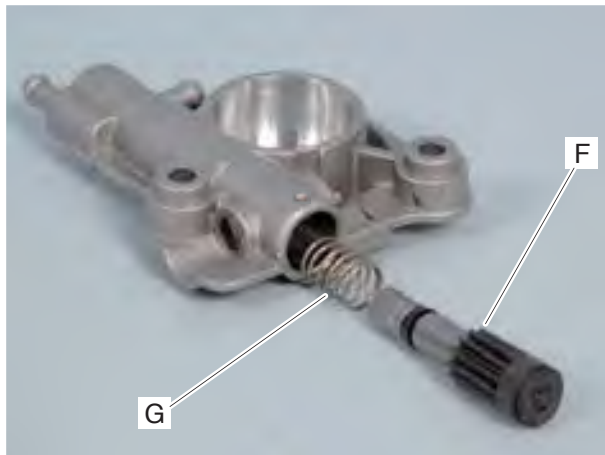

5. Remove plunger (F) and spring (G).
6. Check plunger if worn or broken, and spring if fatigued or broken.

## 7-6 Inspecting V-ring

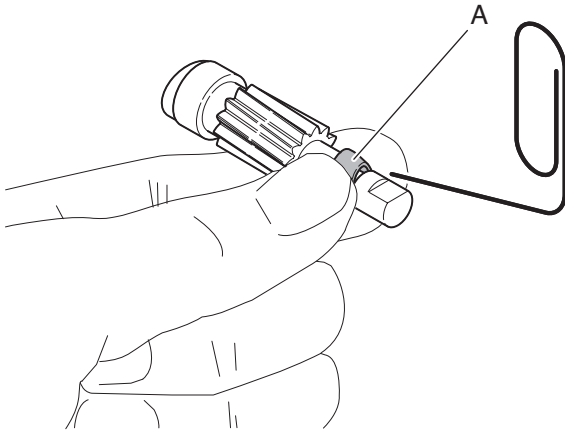

1. Inspect V-ring on plunger as follows.

2. Secure V-ring (A) and insert thin steel wire such as paper clip through the opening as shown.

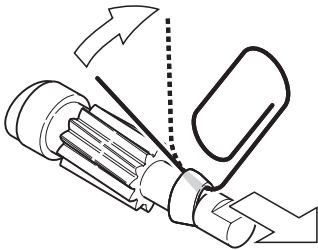

3. Bend steel wire and lift up V-ring from the groove.

4. Slowly rotate plunger while pulling V-ring all the way out.

5. Inspect V-ring for hardness or damage.

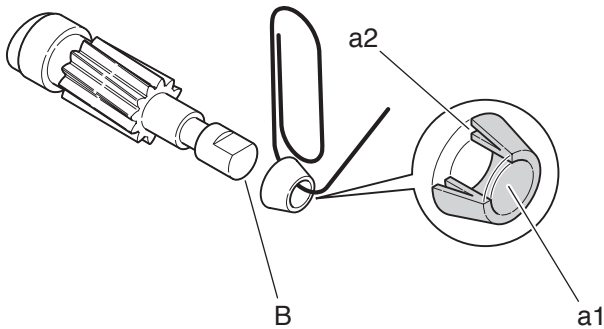

6. Oil inner wall (a1) of V-ring. Hook V-ring with steel wire as shown.

7. Put V-ring on the end (B) of plunger.

**NOTE:** Lips (a2) of V-ring should face gear.

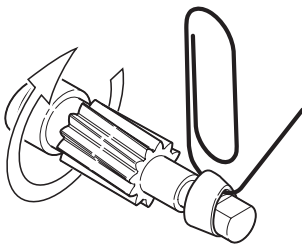

8. Move V-ring into the groove while carefully rotating plunger.

7-7 Assembling auto-oiler parts

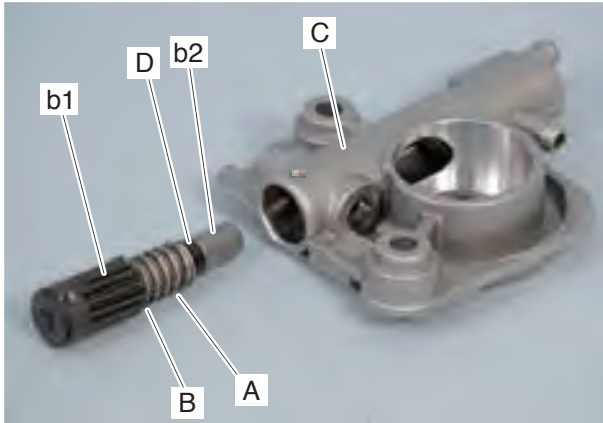

1. Clean inside of cylinder (C).
2. Assemble spring (A) to plunger (B) as shown.
3. Coat plunger gear (b1) and spring (A) with grease and insert into cylinder (C) of auto-oiler body.

**NOTE:** Do not apply grease on V-ring (D) surface and plunger shaft end (b2), for smooth chain oil flow.

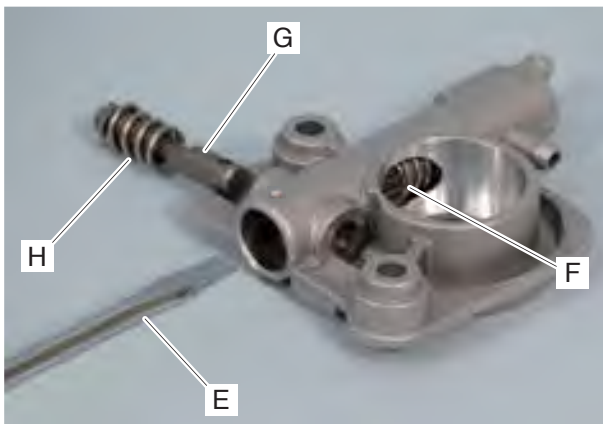

4. Push in plunger with small screwdriver (E), and hold plunger in place with finger through the center hole (F) of auto-oiler body. Remove screwdriver (E).
5. Install adjuster needle (G) with spring (H) into oiler body.



6. Press adjuster needle (G) to the bottom, orienting the flat surface (g1) as shown.



7. Tap in spring pin (J) into hole (g2) of adjuster needle, until spring pin bottoms.

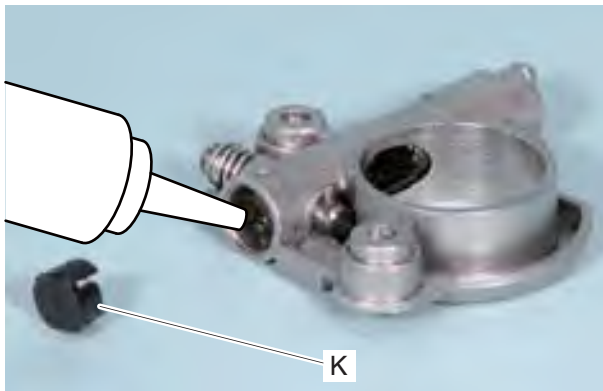

8. Apply grease in plunger cylinder. Push in plug (K) into hole as shown.

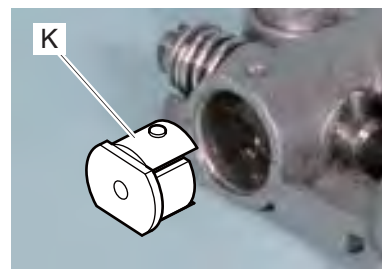

#### 8 ENGINE

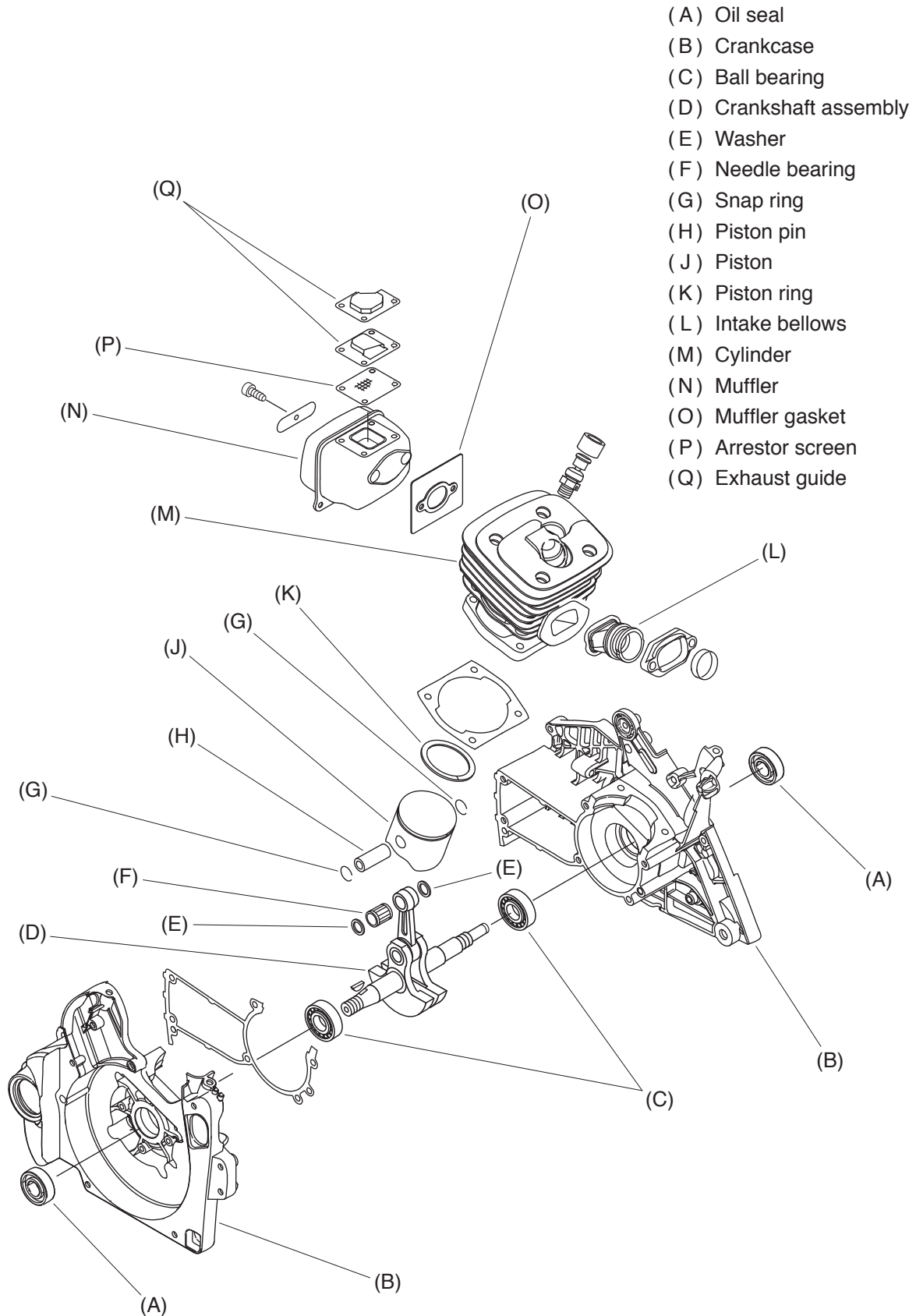



## 8-1 Testing cylinder compression



**NOTE:** Test cylinder compression when engine is cold.

1. Move ignition switch to STOP position. Then remove spark plug.

2. Install compression gauge 91037 (A) in spark plug hole and tighten by hand. Pull starter several times to stabilize reading on compression gauge.

3. If pressure is lower than approx. 75% of standard compression pressure (Refer to “1-2 Technical data ”), inspect cylinder bore, piston, and piston ring for wear or damage.

4. If pressure is more than approx. 125% of standard compression pressure, inspect cylinder combustion chamber and exhaust port, piston crown, and muffler for carbon deposits.

**NOTE:** Compression pressure varies with volume of compression gauge tip occupying cylinder combustion chamber. If gauge tip volume is considerably different from spark plug volume, it is recommended to measure and note compression pressure of brand-new engines as standard pressure in advance.

## 8-2 Cleaning cooling air passages

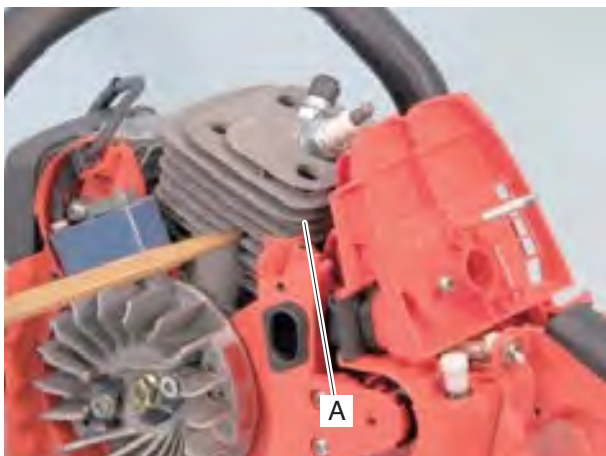

1. Remove cleaner lid and cylinder cover. Remove starter assembly (Refer to “2-1 Disassembling starter assembly”).

**WARNING**  **DANGER**

**Always wear eye protection when using compressed air for cleaning. Otherwise, eye damage can occur from flying particles.**

2. Inspect cylinder cooling fins (A) for blockage with dirt and/or saw dust. Clean them with wooden or plastic stick or compressed air as required.

3. Install all removed parts.

## 8-3 Inspecting muffler and exhaust port



1. Remove cleaner lid and cylinder cover.
2. Remove muffler with muffler gasket.
3. Inspect cylinder exhaust port and clean the port using wooden or plastic stick if carbon is found.

**NOTE:** When cleaning exhaust port, always position piston at Top Dead Center (TDC) to prevent carbon from entering cylinder. Do not use metal tool, and be careful not to scratch piston or cylinder.

**NOTE:** Replace muffler gasket with new one when removing muffler.

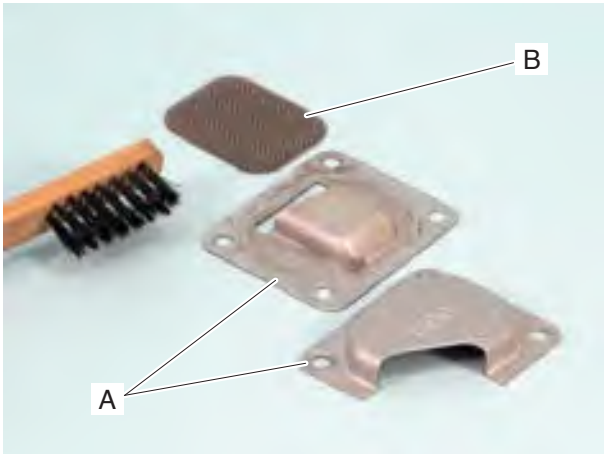

4. Remove exhaust guides (A) and spark arrestor screen (B) from muffler.

5. Remove carbon deposits from spark arrestor screen and exhaust guides. If screen has heavy deposits, replace with new one.

6. Reinstall spark arrestor screen and exhaust guides to muffler.

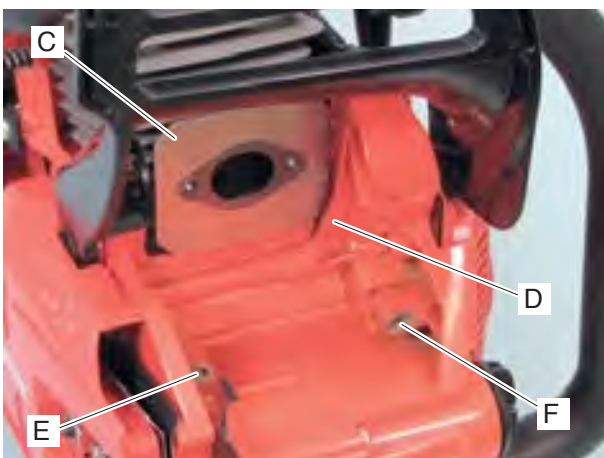

7. Reinstall muffler with new muffler gasket.

**NOTE:** Before reinstalling muffler, apply 2-stroke oil on muffler gasket surface and temporarily paste muffler gasket (C) on cylinder as shown, in order to avoid damage to muffler gasket from wall (D) of crankcase.

**NOTE:** New bolts for bolt hole (E) and (F) are pre-coated with sealant on the thread. If the sealant is peeled off, apply thread locking sealant (Loctite #242, ThreeBond #1324 or equivalent).

## 8-4 Testing crankcase and cylinder seal

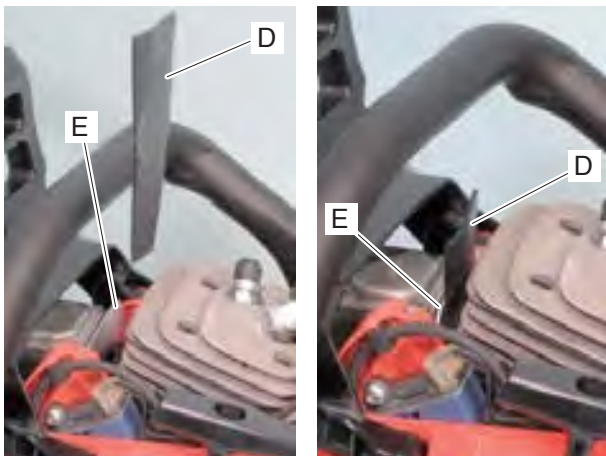
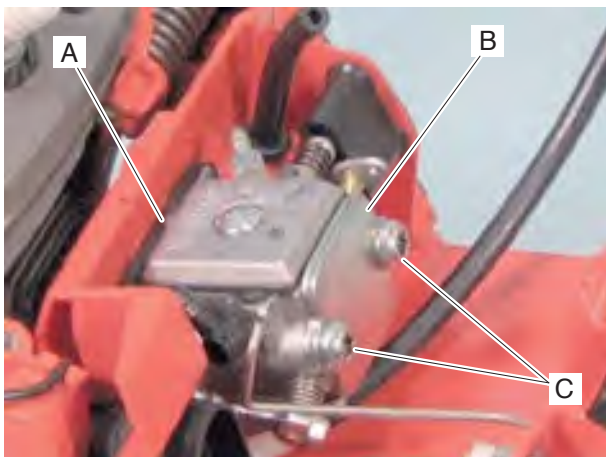

1. Remove cleaner lid, air filter, cleaner case and cylinder cover.

2. Disconnect fuel line, pulse line, throttle rod and choke rod from carburetor, and remove carburetor from the unit.

3. To seal intake port, install pressure rubber plug 897826-16131 (A) between intake bellows and carburetor, using carburetor screws (C). Install pressure plate 897827-16131 (B) between carburetor and screw heads as spacer. Tighten screws (C).

4. Loosen 4 muffler bolts. To seal exhaust port, insert pressure rubber plug 91041 (D) between cylinder exhaust port and muffler gasket (E), until it bottoms.

5. Tighten upper 2 bolts of muffler.

6. Connect pressure tester 91024 (F) to pulse line using provided pipe joint (G).

7. Apply pressure approx. 9.8 kPa (0.1 kgf/cm<sup>2</sup>) (1.4 psi) by pressure tester.

**NOTE:** Do not exceed 30 kPa (0.3 kgf/cm<sup>2</sup>) (4.3 psi). Otherwise, damage to oil seal may occur.

8. If the reading drops, leakage may occur.

9. Leakage may occur from crankcase seam, cylinder base, oil seal and spark plug. Use soapy water to locate leakage.

10. Apply negative pressure approx. 9.8 kPa (0.1 kgf/cm<sup>2</sup>) (1.4 psi) by pressure tester.

11. If the reading drops, leakage may occur from oil seal. Inspect oil seal for damage or wear.

12. Remove pressure tester (F), pipe joint (G) from pulse pipe. Remove pressure rubber plugs (A) (D) and pressure plate (B) from intake bellows and exhaust port.

## 8-5 Inspecting cylinder

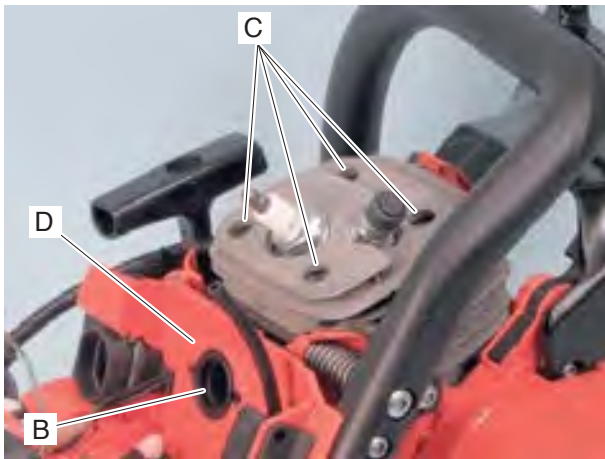
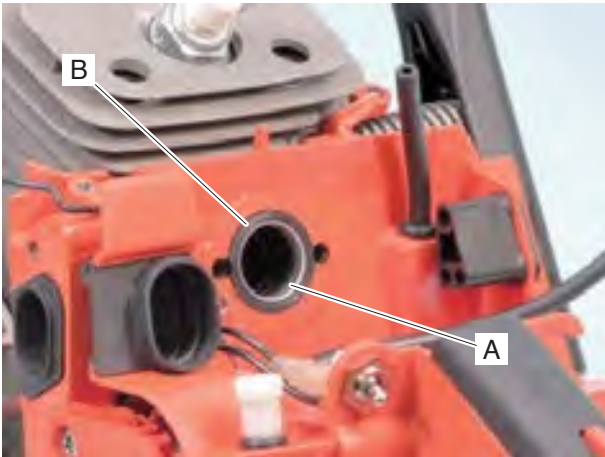

1. Remove carburetor from the unit (Refer to “4-5 Replacing fuel line”).

2. Remove collar (A; metal) from intake bellows (B).

3. Remove muffler with muffler gasket (Refer to “8-3 Inspecting muffler and exhaust port”).

4. Remove 4 bolts from cylinder base through holes (C).

5. Pull out cylinder upward, pushing intake bellows (B) through the wall (D).

6. Inspect cylinder combustion chamber and clean with a plastic or wooden scraper if carbon is found.

**NOTE:** Do not use metal tools, or damage to cylinder wall may result.

7. Inspect cylinder wall and replace with new one if plating is worn, peeled away, scored or exposing cylinder base metal.

## 8-6 Inspecting piston and piston ring

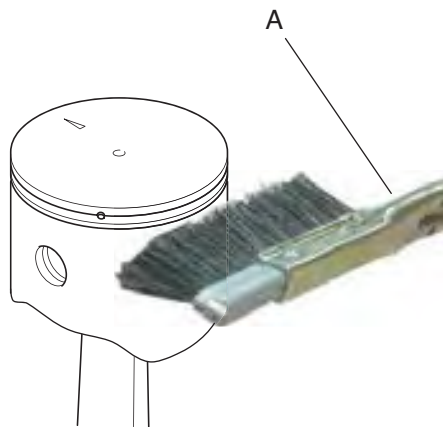

1. Inspect piston ring and replace it if broken or scored, or if it exceeds service limits (Refer to "1-5").

2. Inspect piston crown. Clean with fine sand paper, oil stone, or soft cleaning brush (A) if carbon is found.

3. Inspect top land, ring groove and skirt. Clean them with soft cleaning brush (A) if carbon is found.

**NOTE:** Do not use square end of broken piston ring when cleaning piston ring groove, otherwise piston ring groove might be damaged.

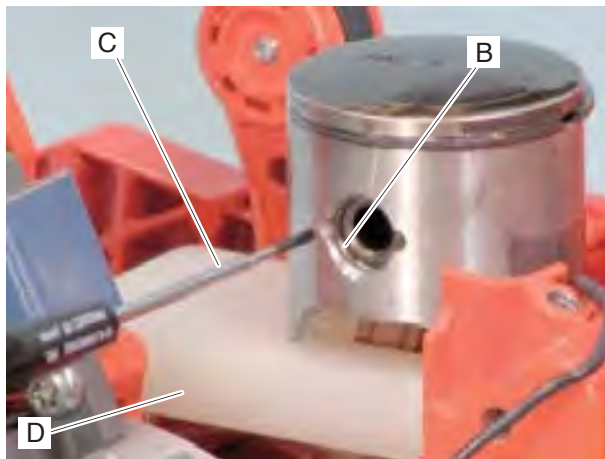

4. Remove snap ring (B) from both sides of piston pin, using small screwdriver (C).

**NOTE:** Piston holder 897719-02830 (D) is recommended.

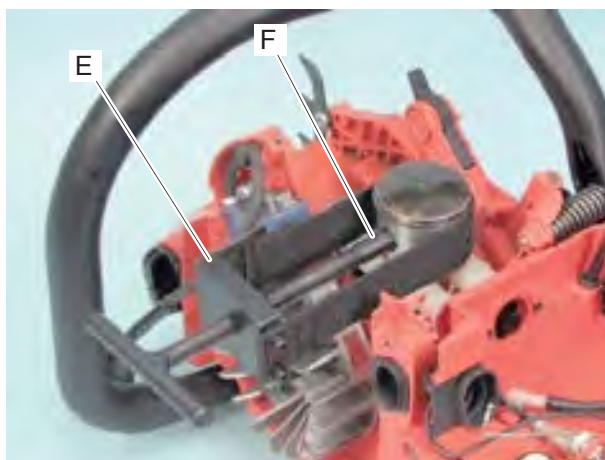

5. Push piston pin out from piston.

**NOTE:** If piston pin is tight, use piston pin tool 897702-30131 (E) with adapter (F) stamped "11" on an end.

6. Inspect needle bearing and washers, and replace if wear or discoloration is noted.

## 8-7 Replacing oil seal

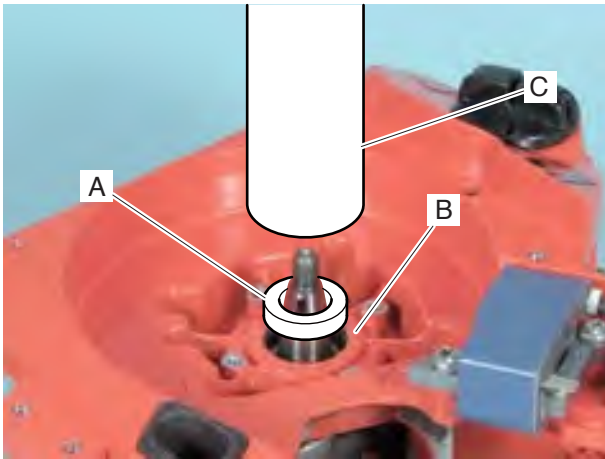

1. Pry defective oil seal from crankcase.

**NOTE:** Be careful not to damage crankshaft and oil seal housing.

**NOTE:** Before removing flywheel side oil seal, remove woodruff key.

2. Apply lithium based grease or ECHO XTended Protection Lubricant on inner rubber lips of new oil seal.
3. Lubricate circumferences of new oil seal with high melting point grease.
4. Push in new oil seal (A) until flush with crankcase surface (B) using oil seal tool 897726-16431 (C).

## 8-8 Disassembling crankcase

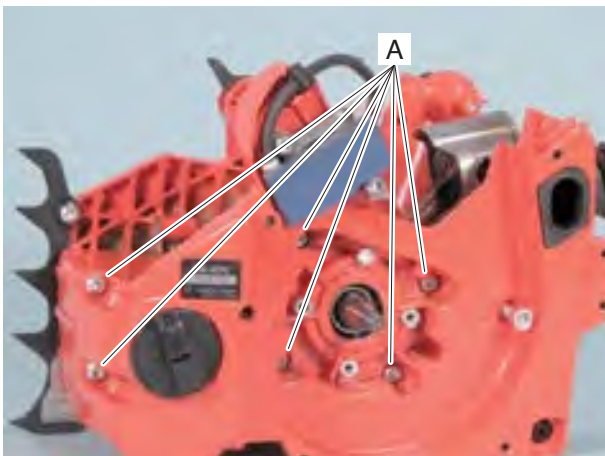

1. Referring to “11-1 Disassembly chart”, remove necessary parts for crankcase disassembly.

2. Remove 6 bolts (A) from crankcase.

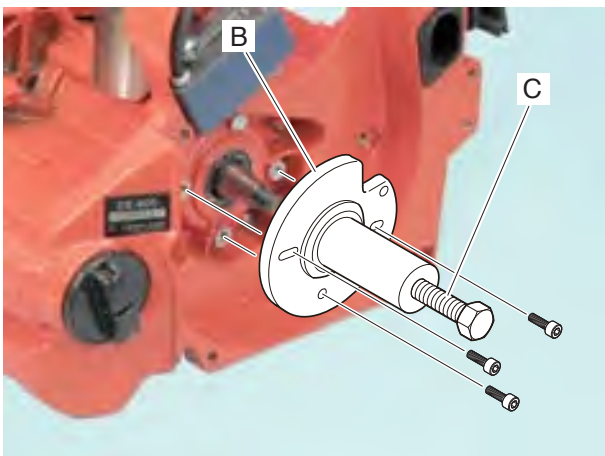

3. Install crankcase tool 897502-19830 (B) with 3 bolts on one side of crankcase halves (in the picture, flywheel side is shown).

4. Tighten bolt (C) to pull crankcase halves apart.

5. Crankshaft remains on the other side of crankcase halves, and can be removed by the same procedure with crankcase tool 897502-19830.

6. Clean and inspect crankshaft and crankcase for damage and discoloration.

## 8-9 Replacing ball bearing and oil seal

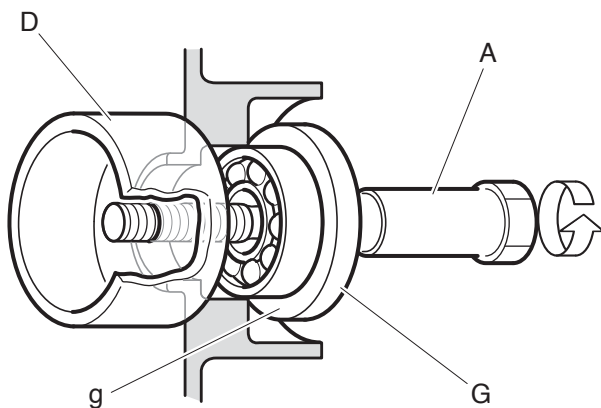
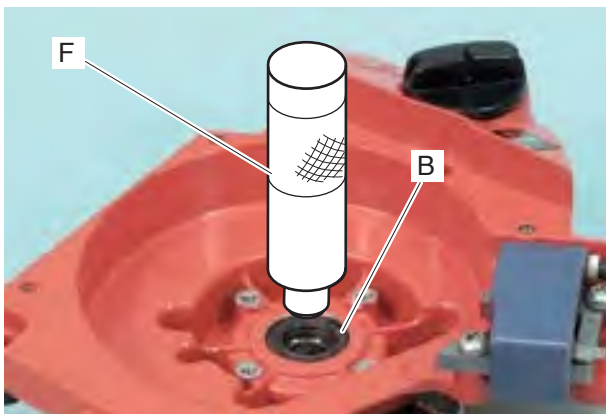
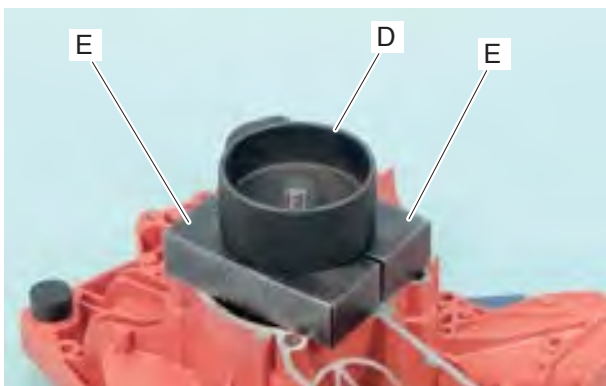
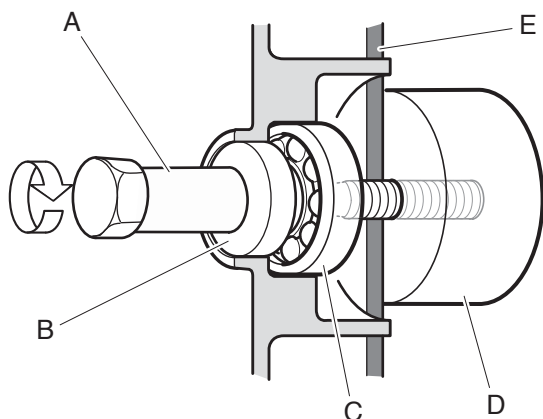

1. After disassembling crankshaft, check ball bearing for smooth rotation. If rough, replace it (them) with new one.

**NOTE:** At the same time, replace oil seal with new one.

2. Remove ball bearing from crankcase half using bearing tool 897701-14732 as follows.

3. Set shaft (A) through oil seal (B) and ball bearing (C), with boss (D) and appropriate thickness metal plates (E) as shown.

4. Tighten shaft (A) with wrench to remove ball bearing (C). Oil seal (B) remains in crankcase bore.

5. Push out oil seal (B) with oil seal tool 897714-12330 (F).

6. Coat bearing housing in crankcase with a lithium based grease.

7. Set ball bearing with shaft (A), adapter (G) (inner dia. 15 mm, outer dia. 40 mm) and boss (D).

**NOTE:** Set adapter (G) mating full flat side (g) to ball bearing.

8. Tighten shaft (A) with wrench to press ball bearing into the crankcase half until flush.

9. Check that bearing rotates smoothly.

## 8-9 Replacing ball bearing and oil seal (continued)

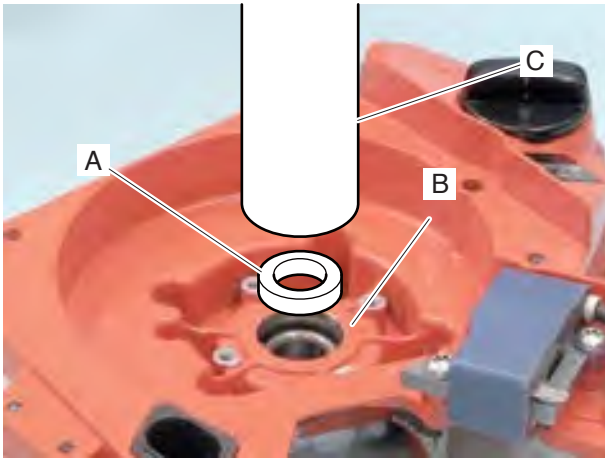

10. Apply lithium based grease or ECHO XTended Protection Lubricant on inner rubber lips of new oil seal.

11. Lubricate circumferences of new oil seal with high melting point grease.

12. Push in new oil seal (A) until flush with crankcase surface (B) using oil seal tool 897726-16431 (C).

## 8-10 Assembling crankshaft and crankcase

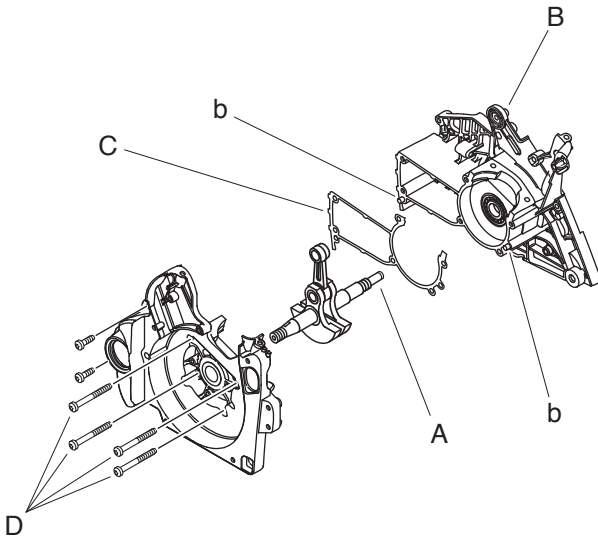

1. Clean mating surface of each crankcase half.

2. Insert crankshaft clutch end (A) into clutch side crankcase half (B) until properly seated.

**NOTE:** If it is hard to insert crankshaft to crankcase, preheat ball bearing for easier installation.

3. Put new crankcase gasket (C) on clutch side crankcase half (B).

4. Reassemble both crankcase halves together ensuring that dowel pins (b) on clutch side crankcase half (B) are properly seated in holes on the other half.

5. Tighten 4 bolts (D) diagonally to secure crankcase halves together, and check crankshaft for smooth rotation.

6. Tighten other 2 bolts.

**NOTE:** Tighten bolts referring to "1-3 Torque limits".



8-11 Installing piston

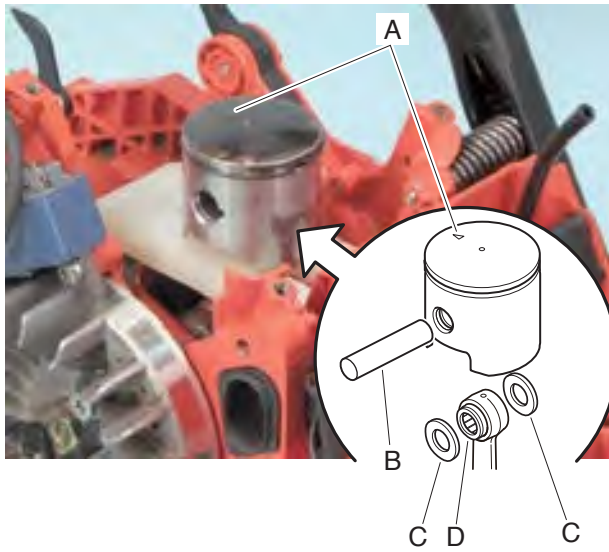

1. Place piston over the small end of connecting rod, so that the arrow mark (A) on piston points front as shown.

2. Insert piston pin guide (B) stamped "11", through piston, washers (C) and needle bearing (D) in connecting rod as shown.

**NOTE:** Piston pin guide (B) is included in piston pin tool 897702-30131.

3. Insert piston pin (E) in piston pushing out piston pin guide (B) using piston pin tool 897702-30131 (G) and piston holder 897719-02830 (F).

4. Install new snap rings to piston using small screwdriver and be sure that they are correctly seated in the grooves.

**NOTE:** If it is hard to install snap rings, modify screwdriver end as shown to hook snap ring.

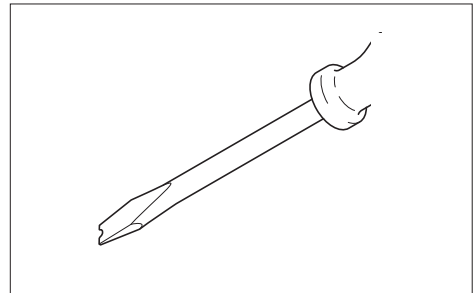
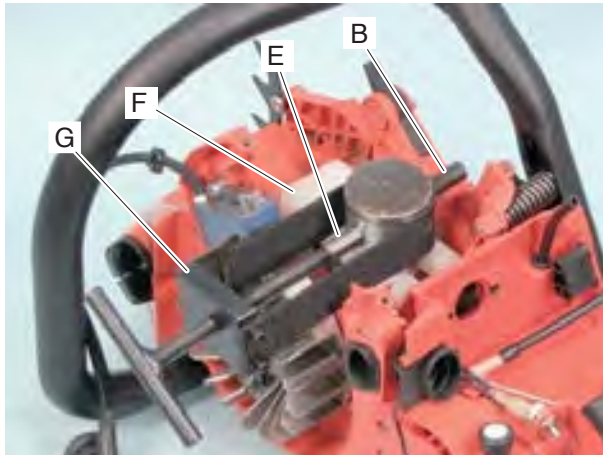

## 8-12 Installing piston ring and cylinder

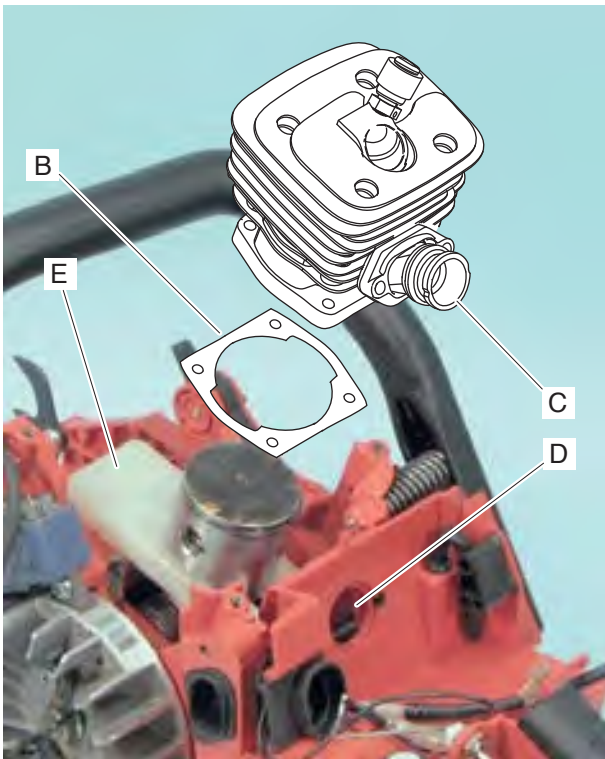
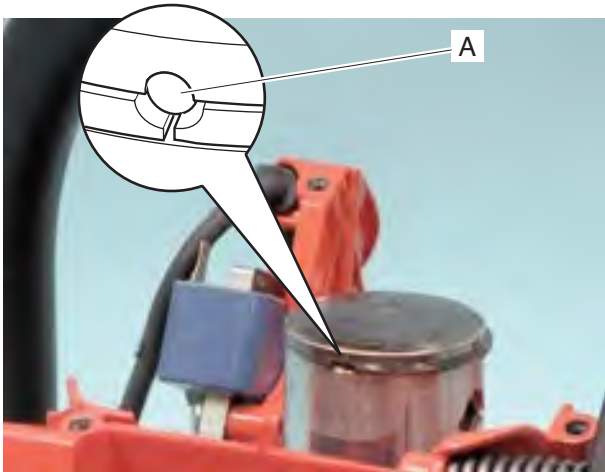

1. Install piston ring on piston, ensuring the end gaps of piston ring are properly positioned around locating pin (A) as shown.

2. Temporarily paste new cylinder gasket (B) on cylinder base with a little glue for easier installation of cylinder.

3. Apply oil to piston ring and internal wall of cylinder.

4. Install cylinder with intake bellows over piston, ensuring that the exhaust side of cylinder should face front as shown.

5. Pull intake bellows (C) through hole (D) with longnose pliers taking care not to damage intake bellows. Set intake bellows correctly.

**NOTE:** When installing cylinder, it is convenient to use piston holder 897719-02830 (E) to stabilize piston.

**NOTE:** When installing piston in cylinder, do not twist cylinder to avoid breakage of piston ring and scoring cylinder bore.

6. Reinstall all removed parts in place.

9 REAR HANDLE AND CONTROL SYSTEM

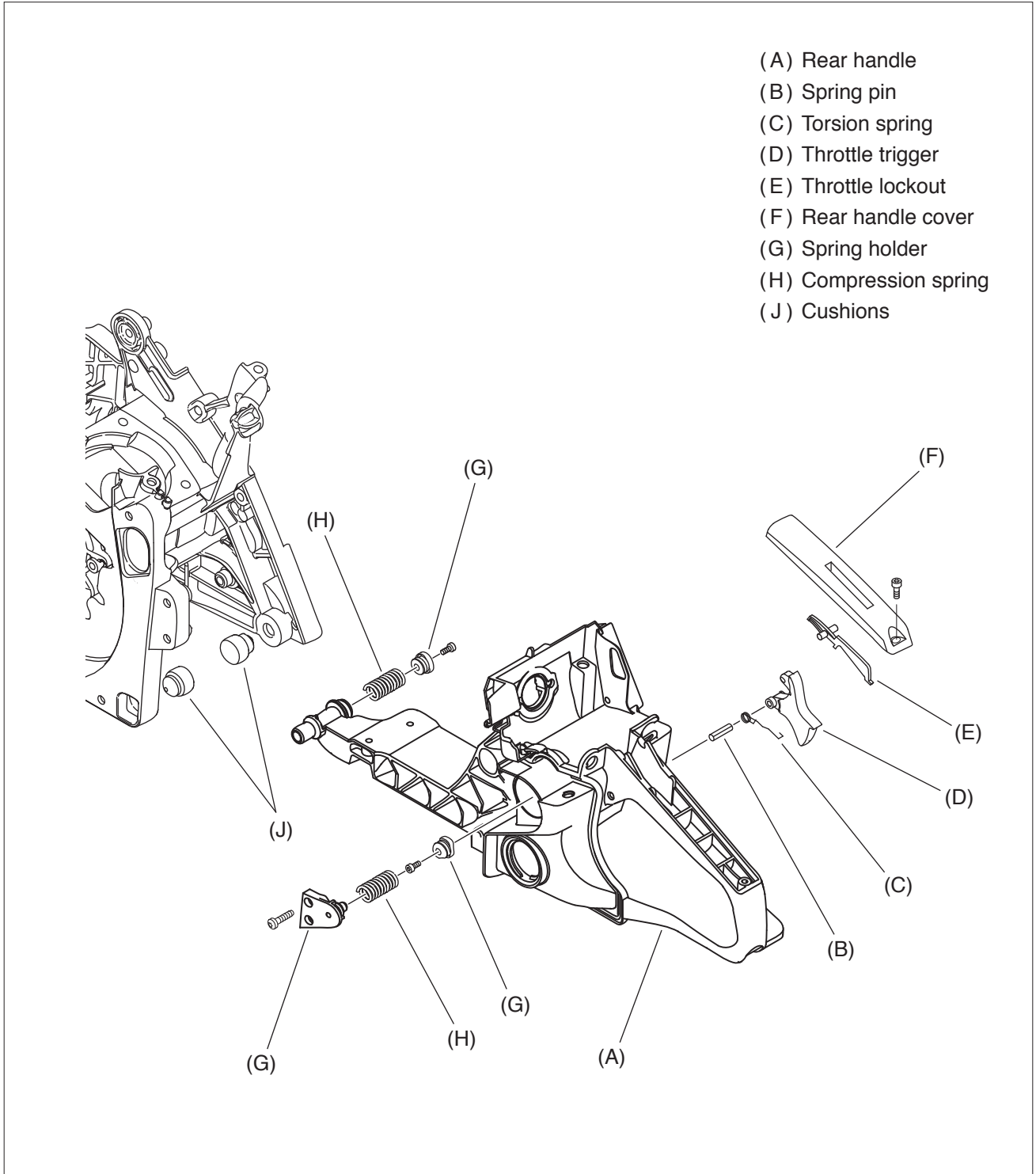

## 9-1 Replacing cushions

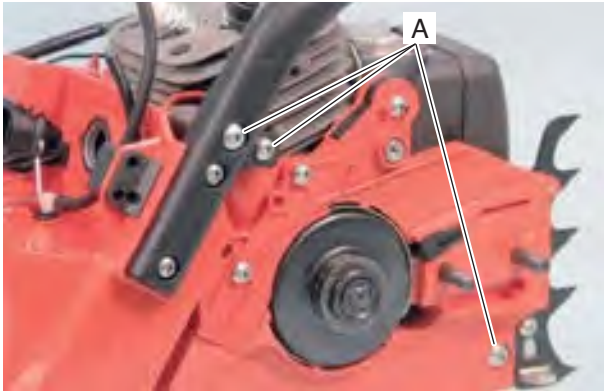

1. Remove starter assembly from the unit (Refer to "2-1 Disassembling starter assembly").

2. Remove cleaner lid, air filter and cleaner case. Disconnect fuel line, pulse line, throttle rod and choke knob from carburetor. Remove carburetor from the unit.

3. Remove three bolts (A).

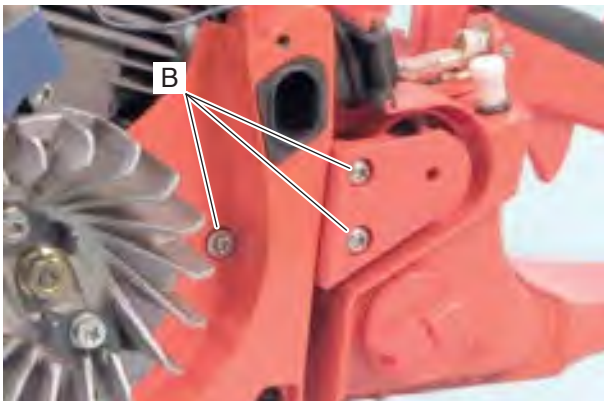

4. Remove three bolts (B) on the other side of the unit.



5. Remove collar (C; metal) from intake bellows (D; rubber).

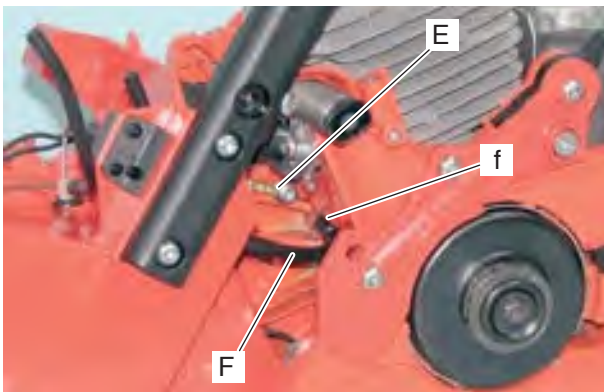

6. Remove ground lead (E) and the end (f) of pulse line (F) from the unit.

## 9-1 Replacing cushions (continued)

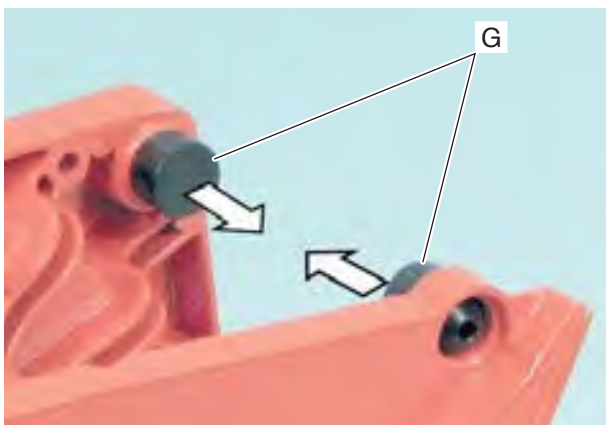

7. Remove rear handle from the unit.

8. Inspect cushions (G) for cracking or wear. If damaged, replace with new cushions as follows.

9. To remove cushions (G), pull by hand in direction of arrows.

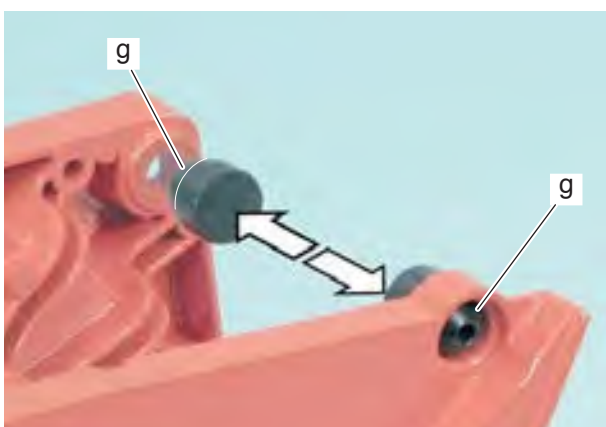

10. Apply lithium-based grease on outer surface (g) of cushion toe, then install cushions by pushing in direction of arrows.

11. Reassemble ground lead (E) and the end (f) of pulse line (F) to the unit. Reassemble intake bellows (D) with collar (C) to rear handle.

12. Reassemble rear handle to the unit. Reassemble all related parts.

## 9-2 Replacing throttle trigger

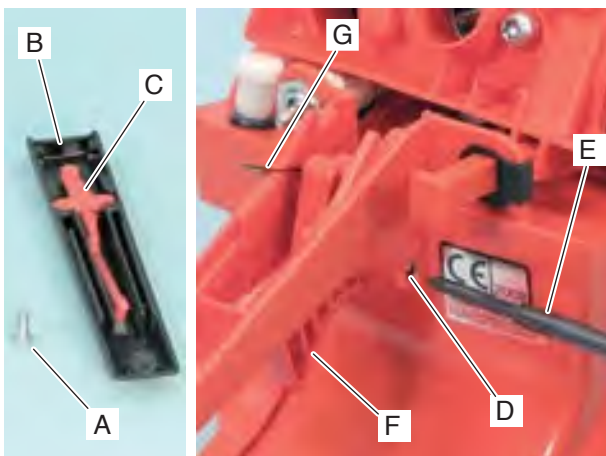

1. Loosen screw (A) and remove rear handle cover (B).

2. Inspect rear handle cover (B) and throttle lock-out (C) for cracking or wear. If damaged, replace it as required.

3. Push out spring pin (D) from rear handle using spring pin tool 897724-01361 (E).

**NOTE:** Spring pin will stop before completely coming off from rear handle, because of effective length of spring pin tool.

4. Remove throttle trigger (F) together with torsion spring (G).

## 9-2 Replacing throttle trigger (continued)

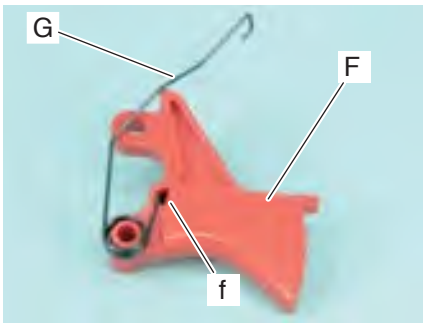

5. Set torsion spring (G) on throttle trigger (F), placing an end of torsion spring in hole (f) of throttle trigger.

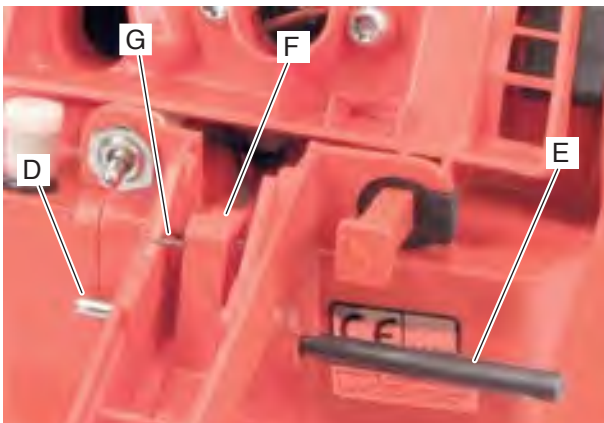

6. Install throttle trigger (F) with torsion spring (G) and insert spring pin (D) as follows.

1) Insert spring pin (D) in the hole of rear handle so the tip of spring pin does not protrude inside handle.

2) Hold throttle trigger (F) with torsion spring (G) in place, and insert spring pin tool (E) from the other side of handle through the hole of throttle trigger.

3) Lightly tap in spring pin (D), pushing out spring pin tool (E).

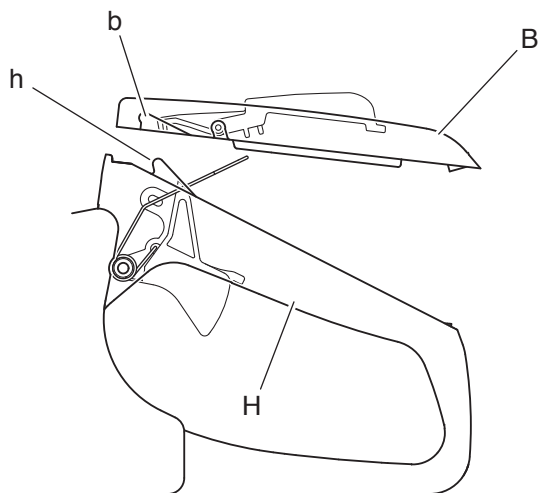

7. Hook the inside notch (b) of rear handle cover (B) on the tab (h) of rear handle (H).

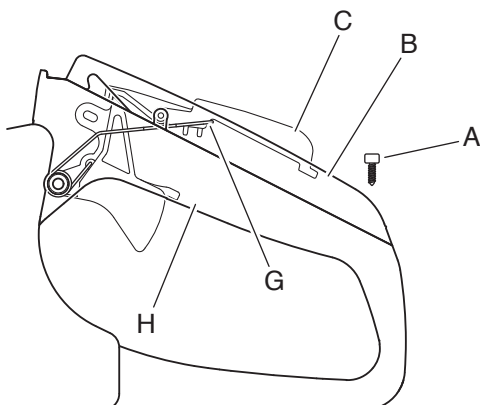

8. Install rear handle cover (B) on rear handle (H), setting torsion spring (G) with throttle lockout (C) as shown.

9. Tighten screw (A) to secure rear handle cover (B). Check throttle trigger and throttle lockout for correct movement.

10 GUIDE BAR MOUNTING SYSTEM

- (A) Sprocket guard
- (B) Inner guide plate
- (C) Outer guide plate
- (D) Tensioner screw
- (E) Chain tensioner
- (F) Collar
- (G) Bevel gear
- (H) Bevel gear

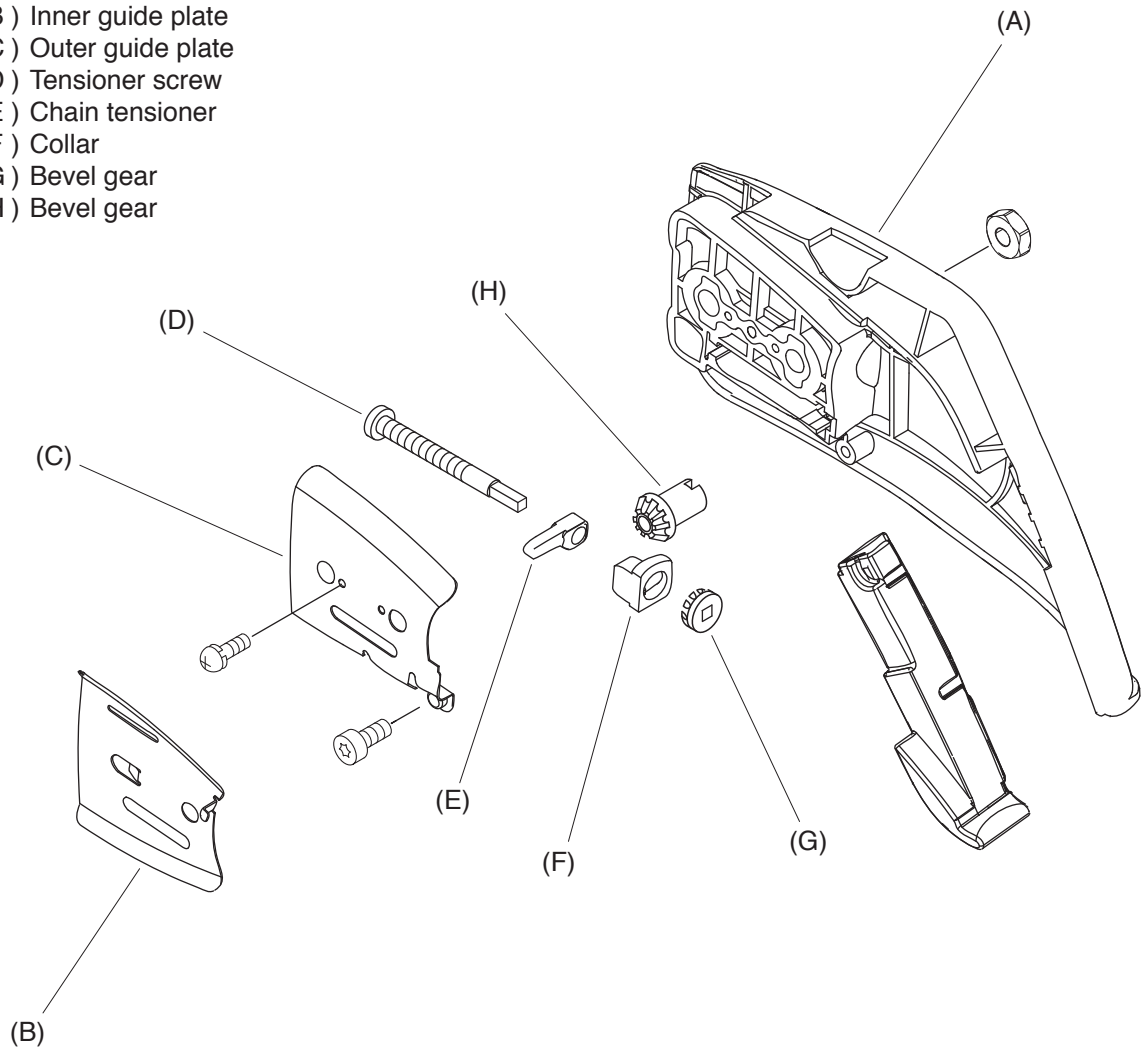

## 10-1 Replacing chain tensioner

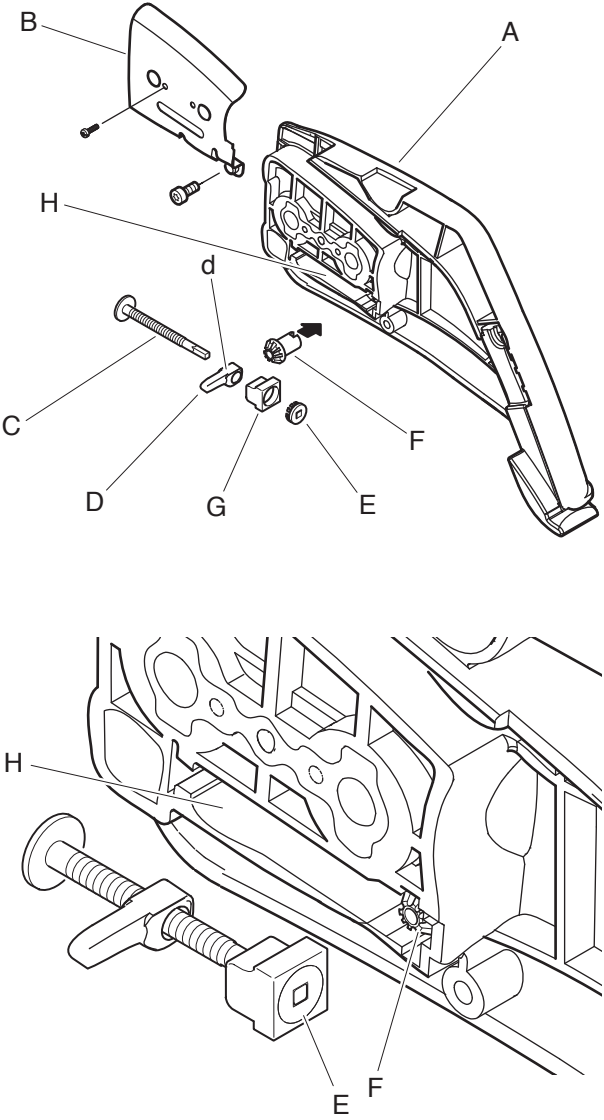

1. Remove sprocket guard (A) from the unit.
2. Remove outer guide plate (B) from sprocket guard. Remove tensioner screw (C), chain tensioner (D) and bevel gears (E) (F) and collar (G).
3. Inspect them for damage or wear. Replace as required.
4. Install bevel gear (F) into sprocket guard.
5. Screw chain tensioner (D) on tensioner screw (C), setting flat side (d) upward.
6. Set bevel gear (E) in collar (G) and insert tensioner screw (C) with chain tensioner (D) in bevel gear with collar (G).
7. Install sub-assembled tensioner screw in slot (H) of sprocket guard, confirming engagement of bevel gear (E) and (F).
8. Reinstall outer guide plate (B).

## 10-2 Replacing guide bar stud

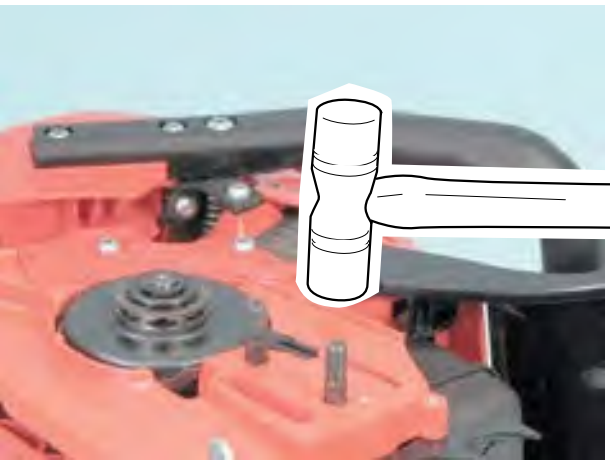

1. Remove oil cap and empty oil from tank.
2. Remove inner guide plate.
3. Tap defective guide bar stud lightly with copper hammer, and push into oil tank. Remove stud from oil tank.



















































## 10-3 Installing guide bar stud

1. Apply adhesive (Loctite #609, ThreeBond 1373 or equivalent) to un-threaded part (A) of new guide bar stud.
2. Install new stud to the stud-hole of oil tank using a pair of tweezers (B).
3. Lightly tap square head of stud with long bar tool (C) and hammer.
4. Install spacer [Bore: 8 to 10 mm (0.32 to 0.39 in), Height: 10 to 12 mm (0.39 to 0.47 in)] (D). Thread M8 nut (E) clockwise onto stud. Turn nut clockwise to pull stud through oil tank mounting hole. The square head of the stud should seat against the oil tank wall parallel with inner ribs.
5. Look into oil tank and check if square head (F) of the stud is properly seated inside crankcase. If not, install two nuts to the stud and secure them against each other.
6. Turn nut (G) clockwise or nut (H) counterclockwise to correct the position of the square head.
7. Repeat step 4 to seat the stud correctly in square hollow inside oil tank.
8. Install all removed parts.

### 11 MAINTENANCE GUIDE

#### 11-1 Troubleshooting guide

TROUBLE	
Engine does not crank.	01
Engine does not start.	02
Fuel leaks.	03
Idling is not stable.	04
Acceleration is poor.	05
Engine stalls at high speed.	06
Engine lacks power.	07
Engine seizure / overheat	08
Engine misfires.	09
Engine / others are extremely noisy.	10
Fuel consumption is excessive.	11
Vibration is excessive.	12
Engine does not stop.	13
Oiler does not function.	14
Saw chain does not cut well.	15

INSPECTING	REFERENCES	Inspecting  first.														
<b>Starter system</b>		15	14	13	12	11	10	09	08	07	06	05	04	03	02	01
Starter pawl/spring	2-4															
Starter drum/rope	2-2															
Rewind spring	2-3															
<b>Ignition system</b>		15	14	13	12	11	10	09	08	07	06	05	04	03	02	01
Sparks	3-2															
Spark plug	3-3															
Spark plug cap / coil	3-7															
Ignition switch	3-4															
Ignition coil	3-6, 3-8															
Pole shoe air gaps	3-9															
Flywheel	3-10															
Flywheel key	3-10															
<b>Clutch system</b>		15	14	13	12	11	10	09	08	07	06	05	04	03	02	01
Clutch shoes/spring/bearing	5-1 to 5-3															
Clutch drum	5-1, 5-3															
Sprocket	1-5, 5-1															
		(Continued)														



### 11-2 Disassembly chart

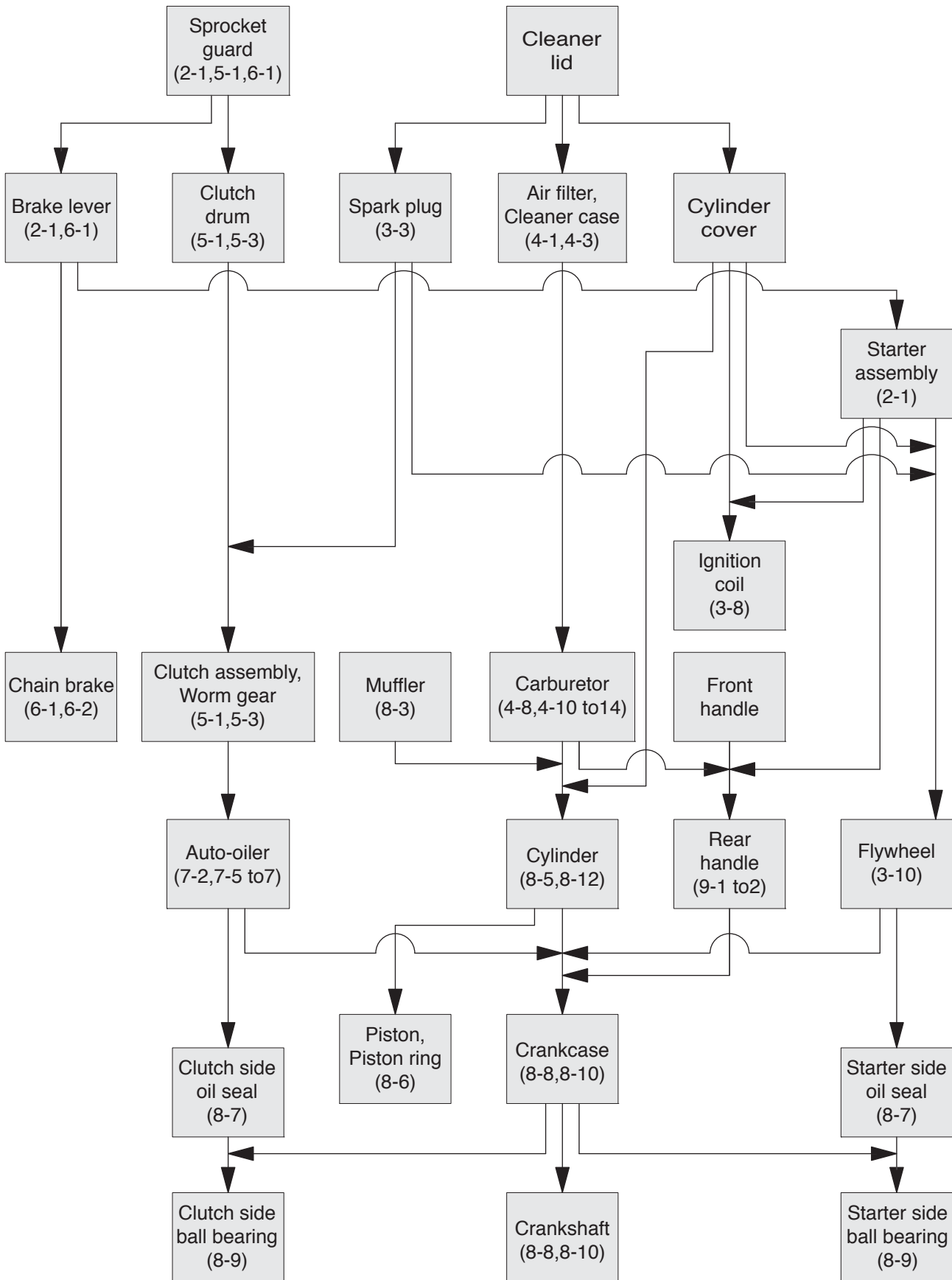

## 11-3 Service Intervals

Inspecting point	Service	Reference	Intervals		
			Daily	3 months or 100 hours	6 months or 300 hours
Screws and bolts *	Retighten / Replace			○	
Air filter	Clean	4-1	○		
	Inspect / Replace	4-1		○	
Carburetor	Inspect / Repair	4-8 to 4-14			○
Fuel leaks	Inspect / Repair	4-2, 4-3	○ **		
Fuel line	Inspect / Repair	4-3, 4-5		○	
Cooling system	Inspect / Clean	8-2	○		
Spark plug	Clean / Regap	3-2, 3-3		○	
	Inspect / Replace	3-3			○
Fuel strainer	Clean / Replace	4-2		○	
Leads and connections	Inspect / Repair	3-5		○	
Fuel tank	Clean inside.	4-3		○	
Muffler and exhaust port	Clean	8-3		○	
Starter system	Inspect / Repair	2-1 to 2-4		○	
Oil tank	Clean inside.			○	
Oil strainer	Clean / Replace	7-1		○	
Sprocket	Inspect / Replace	1-5, 5-1		○	
Guide bar	Inspect / Clean		○		
Chain brake	Inspect / Repair	6-1, 6-2	○		

**Daily:** Inspecting in every services.

**IMPORTANT:** Service intervals shown above are maximum. Actual use and your experience will determine the frequency of required maintenance.

\* Retighten the following screws and bolts after first 1 week use, and every 3 months.

- Cylinder cover screws (3 pcs.)
- Starter assembly screws (4 pcs.)
- Anti-vibration spring screws (2 pcs.)
- Front handle screws (4 pcs.)
- Muffler bolts (4 pcs.)

\*\* Inspect after every refuel.

- Adhesive 5, 71  
Air filter 23 to 26, 28 to 30, 33, 40, 57, 66, 75  
Air shutter 32  
Arrester screen 54, 56  
Auto-oiler assembly 46, 48, 50, 51  
Ball bearing 7, 54, 61, 62  
Bevel gear 69, 70  
Brake band 43, 45, 50  
Brake connector 43, 45  
Brake cover 4, 5, 43 to 45  
Brake lever 4, 9, 43, 44  
Carburetor 2 to 4, 7, 23, 25, 28 to 38, 57, 58, 66, 75  
Carburetor adjustment 29, 30  
Chain brake system 43  
Chain oil discharge volume 3  
Chain tensioner 69, 70  
Choke rod 38, 57  
Cleaner case 18, 23, 25, 28, 32, 33, 38, 57, 66  
Cleaner lid 16 to 20, 23 to 26, 28, 30, 33, 40, 55 to 57, 66  
Clip 28, 50  
Clutch assembly 3, 39 to 42  
Clutch drum 6, 39, 40, 42  
Clutch hub 4, 39, 41  
Clutch plate 39 to 41  
Clutch shoes 40, 41  
Clutch spring 39, 41  
Clutch system 39  
Collar 39 to 43, 58, 66, 67, 69, 70  
Compression gauge 7, 55  
Compression pressure, cylinder 3, 55  
Connector 23, 24, 28, 43, 45, 46  
Cooling air passage, engine 55  
Crankcase 4, 7, 34, 43, 45, 46, 50, 54, 56, 57, 60 to 62, 71  
Crankcase pulse passage 34  
Crankshaft 6, 7, 13, 21, 22, 40 to 42, 54, 60 to 62  
Cushions 4, 5, 65 to 67  
Cylinder 2, 4, 6, 7, 16, 17, 19, 20, 32, 35, 53 to 58, 64, 75  
Cylinder compression 7, 55  
Cylinder seal 57  
Disassembly chart 60, 74  
Engine 2 to 4, 7, 16, 29 to 31, 37, 54, 55, 71  
Exhaust guide 54, 56  
Exhaust port, cylinder 7, 29, 55 to 58, 75  
Flywheel 4, 8, 14, 21, 22  
Fuel cap 23 to 25, 28  
Fuel line 23, 25, 28, 29, 33, 38, 57, 58, 66, 75  
Fuel strainer 23 to 25, 28, 75  
Fuel system 16, 23  
Fuel tank 23 to 25, 26, 28, 75  
Fuel tank vent 23, 25, 26, 27, 29  
Gasket, carburetor diaphragm 33, 34, 36  
Grease 5, 42, 45, 53, 60 to 62, 67  
Grommet, fuel tank 23, 25, 28  
Grommet, oil tank 46, 48, 50  
Ground lead 14, 18, 66, 67  
Guide bar 2 to 5, 69 to 71, 75  
Guide bar mounting system 69  
Guide bar stud 5, 70, 71  
High tension lead 16, 19, 20  
H mixture needle 3, 29 to 31  
Idle adjust screw 3, 29 to 31  
Ignition coil 4, 14, 17, 19 to 21  
Ignition switch 4, 14, 16 to 18, 55  
Ignition system 3, 7, 14, 16  
Ignition timing 3, 7  
Inlet needle valve 33, 35, 36  
Intake bellows 4, 54, 57, 58, 64, 66, 67  
Key, flywheel 21, 22, 60  
Limiter cap 7, 29 to 31  
L mixture needle 3, 29 to 31  
Maintenance guide 72  
Metering diaphragm 34, 36  
Metering lever 3, 33 to 35, 37  
Metering lever height 3, 33, 34  
Minimum secondary voltage 3, 7  
Muffler 2, 4, 5, 29, 54 to 56, 57, 58, 75  
Needle bearing, clutch 5, 39, 40, 42  
Needle bearing, piston pin 54, 59, 63  
Oil cap 46 to 48, 50, 70  
Oil line 46 to 48, 50  
O-ring, fuel cap 23 to 25  
O-ring, oil cap 46 to 48  
Oil seal 5, 7, 54, 57, 60 to 62  
Oil strainer 46, 47, 50, 75  
Oil tank vent 46, 48, 49  
Piston 2, 6, 7, 21, 40, 54 to 56, 59, 63, 64  
Piston pin 6, 7, 54, 59, 63  
Piston ring 6, 54, 55, 59, 64  
Plunger, auto-oiler 51 to 53  
Pole shoe air gaps 3, 7, 20, 21  
Pulse line 23, 28, 33, 34, 38, 57, 66, 67  
Pump diaphragm 33, 36  
Rear handle and control system 65  
Rewind spring 5, 8, 9, 11, 12  
Rewind spring case 8, 9, 11  
Rope reel 8 to 12  
Saw chain 2, 3  
Saw chain lubrication system 46  
Screen, carburetor inlet 36  
Screen, spark arrestor 54, 56  
Secondary coil resistance 3, 19  
Service information 2, 21  
Service intervals 75  
Service limits 6, 59  
Spark plug 2 to 4, 14, 16, 20, 29, 55, 57, 75  
Spark plug cap 14, 19, 20  
Spark plug cap coil 14, 19, 20  
Spark plug gap 3, 16  
Spark tester 7, 16  
Special repairing materials 5  
Special tools 7  
Specifications 2  
Spring, metering lever 3, 33 to 35, 37  
Spring pin 7, 51, 53, 65, 67, 68  
Spring pin tool 7  
Sprocket 2, 4, 6, 39, 40, 42, 75  
Sprocket guard 4, 5, 9, 40, 44, 69, 70  
Starter grip 8, 10, 12, 16, 33, 34, 41  
Starter pawl 4, 5, 8, 13, 22  
Starter rope 8 to 10, 12, 40  
Starter system 8, 75  
Switch lead 14, 17, 18, 20  
Technical data 3, 55  
Test pressure, carburetor 3  
Throttle lockout 65, 67, 68  
Throttle rod 28, 33, 38, 57, 66  
Throttle trigger 65, 67, 68  
Torque limits 4, 21, 62  
Torsion spring 13, 43, 65, 67, 68  
Troubleshooting guide 15, 72, 73  
V-ring 52, 53  
Welch plug 37  
Worm gear, auto-oiler 39 to 41

**ECHO**®

**YAMABIKO**