

**Motoculteur YK 882
Fabrication YANMAR**

YK 882 : 1860210

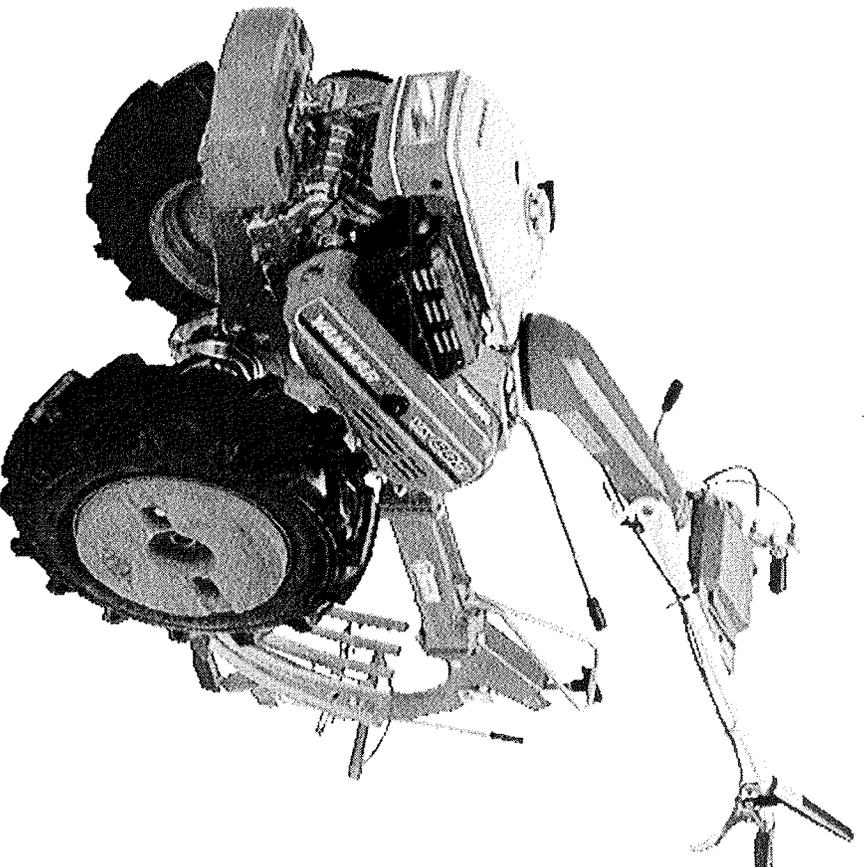

Catalogue pièces de rechange
Catalogue n° 79100340-01
Edition 03/1998



Référence constructeur : YK 682 / YK 882

PUISSANCE VERTE

1, rue de l'Industrie BP 9 68173 RIXHEIM Cedex

Tél : 03 89 64 51 51 Fax : 03 89 64 10 15

Email : courrier@puissance-verte.fr

Internet : www.puissance-verte.fr

Motoculteurs fabrication Yanmar

WWW.PlanDeGraissage.ORG

YOUR PARTS ORDERING

- When placing your parts order with us, Please contact us upon confirming the Model, Part No., Description and Q'ty of the parts you want to order by this parts catalog.
First look for the illustration of the part you want. Then you can find out the necessary informations by tracing the illustration No., as each illustration corresponds to the parts list on the following page.
- All parts the illustrations of which are not numbered shall not be sold separately.
- You are asked to prapare parts, especially consumable parts in the demand season earlier, as orders will come with a rush in this season.
- Parts other than those due to misshipping on your part shall not be allowed to returned in principle.
- Please surely use YANMAR Genuine Parts in any YANMAR Product.
(Use of similar goods (parts) on the market causes earlier damage or worsening of performance.)

HOW TO READ THIS PARTS CATALOG

- In the case where a Ref. No. given in the list does not agree with the corresponding Sketch No. in illustration (no suffix number as shown below), an illustration for such a New Part has been omitted only in the case of a parts change for which Interchangeability Symbol N, R or K is given.

[Example]

Sketch No. in Illustration	Ref. No. in List	
1	1	(Before the change)
2	1 	(After the change)
	2	

- Indication and meaning of level
Level

-A number of dots indicated is called the level which refers to the assembly-component relation of an assembly part.
(“.” refers to an assembly part.)
-Refers to a component included in an assembly part indicated by one dot (•).
-Refers to a component included in a complete part indicated by two dots (••).
(It indicates a sub-componet of pertinent assembly part indicated by one dot (•).)

- Indication and meaning of interchangeability symbol

(Given under the column "I" next to the quantity column in the list)

In the case where a parts change took place, one of the following interchangeability symbols is indicated for that part:

Symbol	Interchangeability	Contents note
N	New  Old 	New Part is interchangeable for Old Part but not interchangeable conversely.
P	New  Old 	Same as symbol N but supply of Old Part is suspended and New Part is sold in the future.
O	New  Old 	New Part is not interchangeable for Old Part but interchangeable conversely.
R	New  Old 	New Part is interchangeable for Old Part and vice versa.
S	New  Old 	New Part is not interchangeable for Old Part and vice versa.
W		Part newly added.
Z		Part discontinued.
F		Not interchangeable by single part but interchangeable by set of the related parts.
K		Changed only in quantity used.

- Remarks (column "R" given at the right end of the list)

9-1) A numerical or alphabetic character (symbol) may be indicated under the column "R".

9-2) A comment (remarks) for a part in question is given at the lower part of the list, following a symbol identical to the aftermentioned symbol when a symbol is indicated under the column "R".

- Virtual No. in illustration

A Sketch No. in illustration containing an encircled numeral indicates other related Group No.

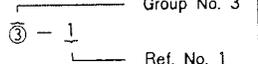
[Example]  indicated.

- Change Effective Machine No.

When a part is changed, a Change Effective Machine No. of such a model for which a New Part is applied is indicated as follows:

[Example] Model columns A ~ F

(Model indication is given in two kinds, namely, 4-model and 6-model indications.)
correspond to A ~ F in front of Change Effective Machine No..

4-model Indication

(A) =
(B) =
(C) =
(D) =

6-model Indication

(A) =	(D) =
(B) =	(E) =
(C) =	(F) =

[Example] A=F610001 B=F612001

Model column A indicates that a parts change is put into effect from Machine No. 610001 and on. And moreover Model column B indicates that a parts change is put into effect from Machine No. 612001 and on.

[Classification]

E Engine No.
F Machine Body No.
R Rotary Unit No. } indicated.

- Additional Group No. found in the Revised Edition

Kindly understand that a Group No. other than consecutive numbers has been entered in the case where the corresponding Group is added within the pertinent Section.

[Example]

Section

BODY SECTION

Group No. Group name

- 46. ENGINE FIXTURE & BATTERY
- 47. FRAME & HYDRAULIC PUMP
- 48. BEVEL GEAR CASE
- 49. TRANSM. CASE & RUNNING CLUTCH
- 50. CONTROL LEVERS
- 51. CRAWLER
- 64. ENGINE FIXTURE & BATTERY (Group added for the YSR1300-N)
- 65. CONTROL LEVERS (Group added for the YSR1300-N)

SNOW REMOVAL SECTION

- 52. CHUTE
- 53. SNOW REMOVAL FRAME & BLOWER

Additional Groups are indicated.

Owing to the improvement of YANMAR Product involved or its parts, the contents of this Parts Catalog may be altered without prior notice to you.

SPECIFICATIONS

Model		YK682	YK882	Note
Engine	Model	YANMAR GA180	YANMAR GA220	
	Type	OHV, 4 cycle-gasoline		OHV : Over Head Valve
	Bore X stroke (mm)	1-68X48	1-70X56	
	Displacement (cc)	174	215	
	Ignition system	TIC		TIC : Transistor Ignition Control system
	Output(max.) (ps/rpm)	6.2 / 4000	8.0 / 4000	
	Oil capacity (ℓ)	0.6	1.0	
	Air cleaner	Oil bath		
	Fuel tank capa. (ℓ)	4.3		
Dimension	Overall length (mm)	1620	1670	
	Overall width (mm)	630		
	Overall height (mm)	790 (from axle center)		
Weight(dry) w/o tires (kg)		65	75	
Speed shifting	Speeds		F 6 , R 2	
	System	Main shift	Sliding gear	
		Sub. shift	Sliding gear	
Axle (at rated engine speed)	Forward speed	1 st (rpm)	10.2	
		2 nd (rpm)	15.9	
		3 rd (rpm)	30.9	
		4 th (rpm)	48.1	
		5 th (rpm)	76.2	
		6 th (rpm)	118.3	
	Reverse speed	1 st (rpm)	12.6	
		2 nd (rpm)	19.5	
Shape of axle (mm)		Hexagon (face to face 26)		
Main clutch		Deadman lever		Belt tension clutch
Side clutch		Yes		
Adjusting area of handle	Horizontal		Yes	
	Vertical		Yes	
Hitch-size (front, rear) (mm)		95		
P.T.O shaft	Speed (rpm)	700		
	Shape of shaft (mm)	φ 20 (with key)		
Transmission oil capacity (ℓ)		2.8		
Applicable max. tire & weight	Tire size		6.00-12	
	Wheel weight (kg)	40X 2 pcs.		
	Front weight (kg)	20		

NOTE : Given specifications may be altered for improvement, etc. without prior notice.

PAINTING COLOR

SECTION	PAINTING COLOR	COLOR SPRAY	MAIN PARTS	COLOR CODE (FIGURE)
Main body	YANMAR Red 1	T.O.R-90400003	Handle frame CMP	5 0
Main body	YANMAR White	T.O.R-90250002	Handle CMP	1 4
Main body	YANMAR Plain silver M2	T.O.R-90310003	Engine frame CMP	1 9

Please surely use **YANMAR** Genuine color spray any **YANMAR** agricultural machines.

Given painting color may be altered for improvement, etc. without prior notice.

CONTENTS

YOUR PARTS ORDERING.....	1A02
SPECIFICATIONS.....	1A03
PAINTING COLOR.....	1A04

ENGINE UNIT(GA180E-SKA)	1B02
GROUP NO. GROUP NAME	
1. CYLINDER BLOCK	1B03
2. CYLINDER HEAD & BONNET	1B04
3. LABEL	1B05
4. AIR CLEANER & MUFFLER	1B06
5. CRANKSHAFT,PISTON & CAMSHAFT	1B07
6. FUEL OIL TANK & FUEL OIL LINE	1B08
7. CARBURETOR	1B09
8. GOVERNOR & CONTROL DEVICE	1B10
9. FLY.MAGNET & STARTING DEVICE	1B11
ENGINE UNIT(GA220E-SKA)	1C02
1. CYLINDER BLOCK	1C03
2. CYLINDER HEAD & BONNET	1C04
3. LABEL	1C05
4. AIR CLEANER & MUFFLER	1C06
5. CRANKSHAFT,PISTON & CAMSHAFT	1C07
6. FLY.MAGNET & STARTING DEVICE	1C08
7. FUEL OIL TANK & FUEL OIL LINE	1C10
8. CARBURETOR	1C11
9. GOVERNOR & CONTROL DEVICE	1C12
PULLEY & TENSION SECTION	1D02
1. ENGINE MOUNTING & PULLEY	1D03
2. MAIN PULLEY & TENSION	1D04
TRANSMISSION UNIT	1D05
3. TRANSMISSION CASE	1D06
4. MAIN & COUNTER SHAFTS	1D07
5. BRAKE SHAFT & REDUCTION SHAFT	1D08
6. AXLE	1D09
7. MAIN & SUB-CHANGES	1D10

GROUP NO.	GROUP NAME	
8.	SIDE CLUTCH	1D11
	WHEEL SECTION	1D12
9.	FENDER	1D13
20.	TIRE(ADDITIONAL ITEM)	1D14
	HANDLE SECTION	1D15
10.	HANDLE COLUMN(MOVE-ROUND)	1D16
11.	HANDLE	1E01
12.	TRAVELING CONTROL LEVER	1E02
	ENGINE FRAME SECTION	1E03
13.	ENGINE FRAME & HITCH	1E04
14.	BELT COVER	1E05
15.	BONNET	1E06
	LABELS & ACCESSORIES SECTION	1E07
16.	ELECTRICAL PARTS	1E08
17.	LABELS	1E09
18.	TOOLS	1E10
19.	ACCESSORIES(ADDITIONAL ITEM)	1E11
21.	LABEL (SAFETY (ADDNL.ITEM)	1E12
	PARTS INDEX	1M01

1. CYLINDER BLOCK

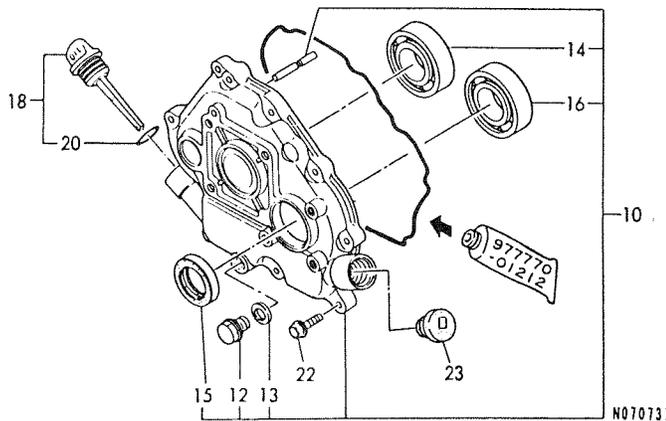
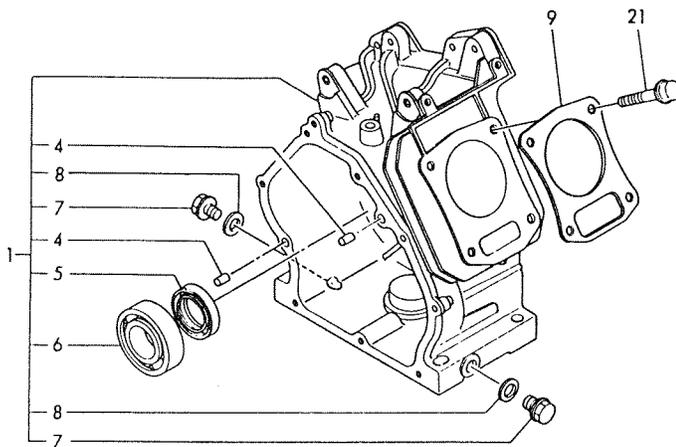

-----+
| 1B03 |
| (1B02) |
-----+
NPC-2437

1. CYLINDER BLOCK

98.03.18

(A)=GA180E-SKA (D)=
(B)= (E)=
(C)= (F)=

REF. NO.	LEV. 0	PART NO.	DESCRIPTION	-----Q'TY-----						I	P/U	A	R
				(A)	(B)	(C)	(D)	(E)	(F)				
1	.	760698-01560	BLOCK ASSY, CYLINDER	1								1	
4	..	22312-080120	PARALLEL PIN 8X12	2								10	
5	..	160690-02220	OIL SEAL TC25416	1								1	
6	..	24101-062050	BALL BEARING	1								1	
7	..	160610-01690	PLUG, DRAIN	2								1	
8	..	104200-59170	GASKET 12	2								5	
9	.	160698-01330	GASKET, CYL. HEAD	1								1	
10	.	760690-01500	COVER ASSY, SIDE	1								1	
12	..	160610-01690	PLUG, DRAIN	1								1	
13	..	104200-59170	GASKET 12	1								5	
14	..	24101-062050	BALL BEARING	1								1	
15	..	160690-02220	OIL SEAL TC25416	1								1	
16	..	24101-062050	BALL BEARING	1								1	
18	..	160710-01760	CAP, W/LUB.OIL GAUGE	1								1	
20	..	24311-000180	O-RING 1A P-18.0	1								10	
21	.	160610-04201	BOLT M 8X 53	4								1	
22	.	26476-060252	BOLT M 6X 25, TAPPING	8								10	
23	.	160110-01870	PLUG, RUBBER W/SCREW	1								1	

-----+
| (REMARKS) "EFFECTIVE MACHINE NO." OF
| ENGINE IS INDICATED ON THE
| ENGINE LABEL WHICH IS SHOWN
| IN FIG.9.
-----+

-----+
| (REMARKS) "EFFECTIVE MACHINE NO." OF
| (チリウ) エンジンノ シラツシコウキ ノ コウモクNO.9 / | (REMARKS) "EFFECTIVE MACHINE NO." OF
| キタイメイハシノ コウキチキス。
-----+

ENGINE IS INDICATED ON THE
ENGINE LABEL WHICH IS SHOWN
IN FIG.9.

2. CYLINDER HEAD & BONNET

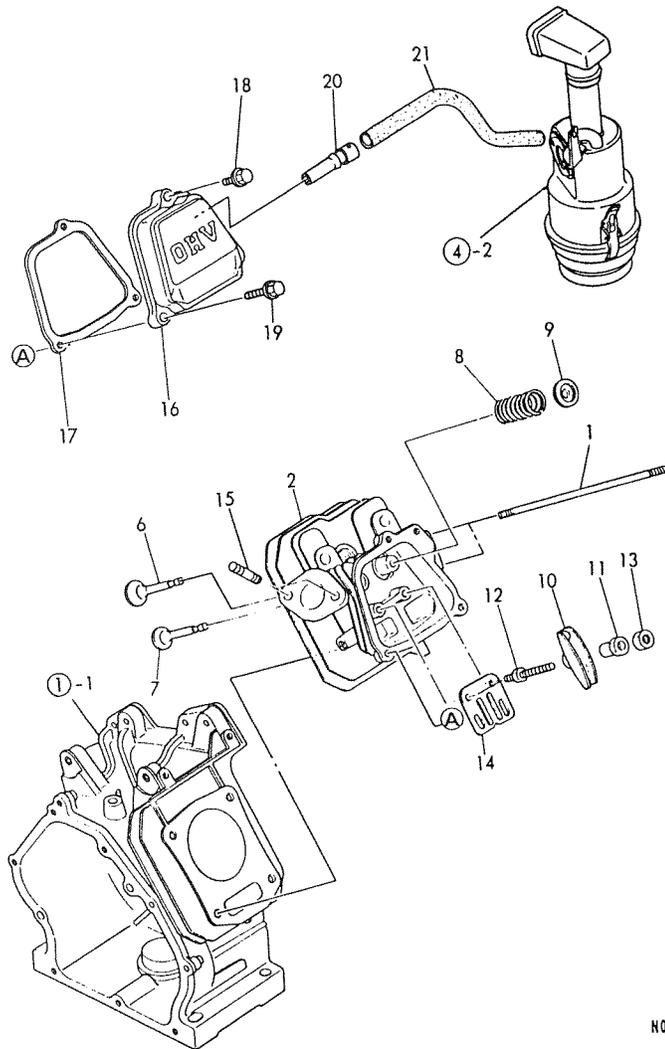

N070732

(REMARKS) "EFFECTIVE MACHINE NO." OF
ENGINE IS INDICATED ON THE
ENGINE LABEL WHICH IS SHOWN
IN FIG.9.

1804
(1802)
NPC-2437

2. CYLINDER HEAD & BONNET

98.03.18

(A)=GA180E-SKA (D)=
(B)= (E)=
(C)= (F)=

REF. NO.	LEV. 0	PART NO.	DESCRIPTION	Q'TY						I	P/U	A	R
				(A)	(B)	(C)	(D)	(E)	(F)				
1	.	160692-04310	BOLT M6X143	2								1	
2	.	160690-11010	HEAD ASSY, CYLINDER	1								1	
6	.	160690-11100	VALVE, INTAKE	1								1	
7	.	160690-11110	VALVE, EXHAUST	1								1	
8	.	160690-11120	SPRING, VALVE	2								1	
9	.	160690-11180	RETAINER, SPRING	2								1	
10	.	160690-11200	ARM, ROCKER	2								1	
11	.	160690-11220	PIVOT, ROCKER ARM	2								1	
12	.	160690-11270	BOLT	2								1	
I 12-	1	160690-11271	BOLT	2							N	1	
		(A=EO9751)											
13	.	160690-11280	NUT M6X 0.5	2								1	
14	.	160690-11290	PLATE, GUIDE	1								1	
15	.	26216-080182	STUD M 8X 18 PLATED	2								10	
16	.	160690-11300	BONNET	1								1	
17	.	160690-11310	GASKET, BONNET	1								1	
18	.	26106-060202	BOLT M 6X 20 PLATED	1								10	
19	.	26106-060352	BOLT M 6X 35 PLATED	2								10	
20	.	160690-03050	BREATHER	1								1	
21	.	160820-03180	PIPE, BREATHER	1								1	

REMARKS
(チヨウ) エンジンノ シヤツシヨウキ ノ コウモクNO.9 ノ (REMARKS) "EFFECTIVE MACHINE NO." OF
キタイメイハシノ コウキチヤス。 ENGINE IS INDICATED ON THE
ENGINE LABEL WHICH IS SHOWN
IN FIG.9.

N070732

3. LABEL

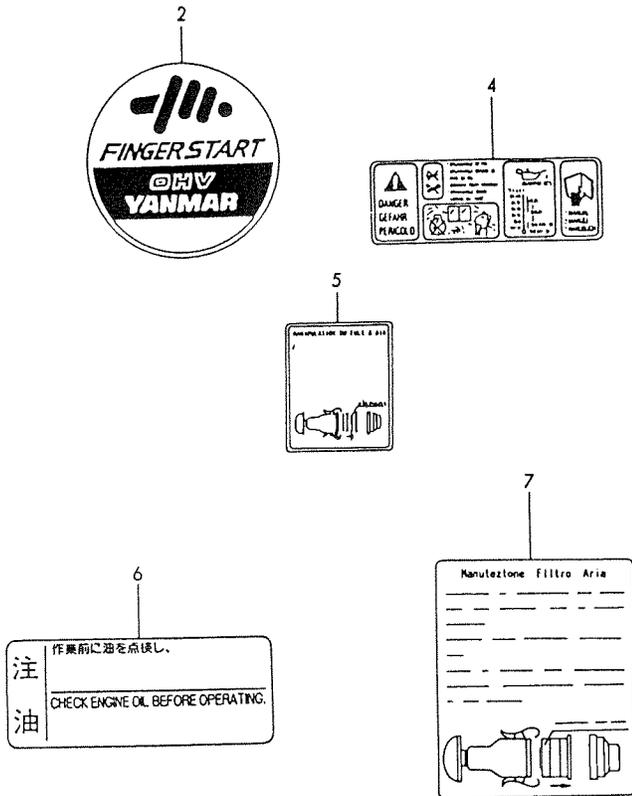

N070733

 | (REMARKS) "EFFECTIVE MACHINE NO." OF
 |
 | ENGINE IS INDICATED ON THE
 | ENGINE LABEL WHICH IS SHOWN
 | IN FIG.9.
 |

 | 1805 |
(1802)
 NPC-2437

3. LABEL

98.03.18

(A)=GA180E-SKA (D)=
 (B)= (E)=
 (C)= (F)=

REF. NO.	LEV. 0	PART NO.	DESCRIPTION	-----Q'TY-----						I P/U A R
				(A)	(B)	(C)	(D)	(E)	(F)	
2	.	160798-07100	LABEL, FINGER START	1						1
4	.	160708-07260	MARK, CAUTION	1						1
5	.	160602-07370	LABEL, AIR CLEANER	1						1
6	.	160692-07370	LABEL, AIR CLEANER	1					W	1
		(A=E04565)								
7	.	160698-07350	LABEL	1					W	1
		(A=E04565)								

----- REMARKS -----
 (チユウ) エンジン油の 点検を 作業前に 必ず 行なう。 / (REMARKS) "EFFECTIVE MACHINE NO." OF
 キタイメイハシノ コウキテマス。 | ENGINE IS INDICATED ON THE
 | ENGINE LABEL WHICH IS SHOWN
 | IN FIG.9.

N070733

4. AIR CLEANER & MUFFLER

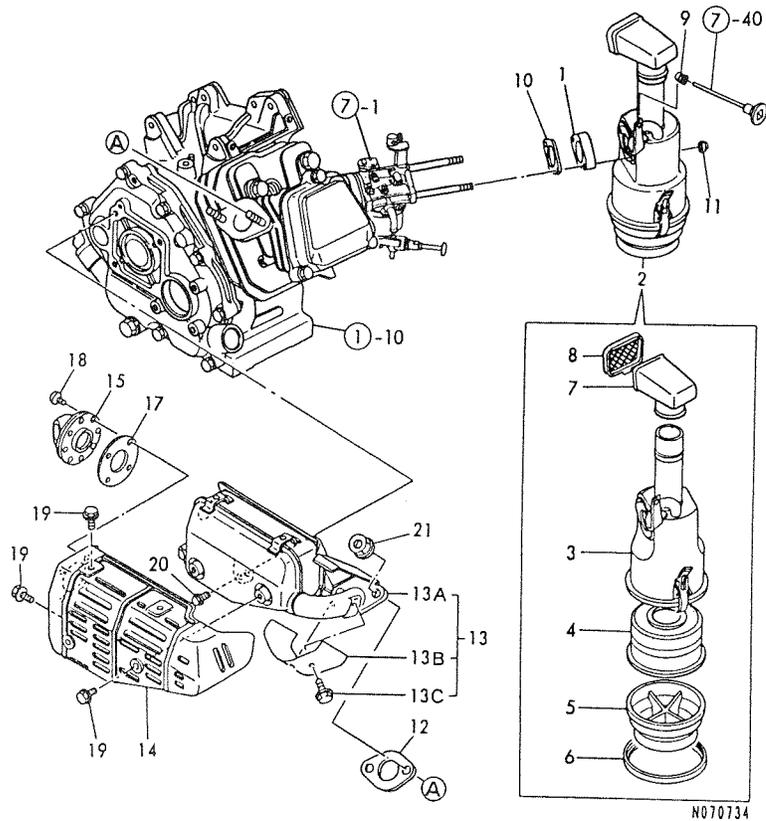

 (REMARKS) "EFFECTIVE MACHINE NO." OF
 ENGINE IS INDICATED ON THE
 ENGINE LABEL WHICH IS SHOWN
 IN FIG.9.

 1806
 (1802)

 NPC-2437

4. AIR CLEANER & MUFFLER

98.03.18

(A)=GA180E-SKA (D)=
 (B)= (E)=
 (C)= (F)=

REF. NO.	LEV. 0	PART NO.	DESCRIPTION	Q'TY						I	P/U	A	R
				(A)	(B)	(C)	(D)	(E)	(F)				
1	.	160690-12261	SPACER, AIR CLEANER	1								1	
2	.	160692-12500	CLEANER ASSY, AIR	1								1	
3	..	160692-12510	BODY ASSY	1								1	
4	..	160692-12520	ELEMENT ASSY, AIR CL.	1								1	
5	..	160692-12530	SUMP, OIL	1								1	
6	..	160692-12540	RING	1								1	
7	..	160762-12870	CAP, INTAKE	1								1	
8	..	160692-12920	NET	1								1	
9	.	160763-12600	GROMMET, AIR CLEANER	1								1	
10	.	160610-56150	GASKET, CARBURETOR	1								1	
11	.	26657-060002	CAP NUT M 6	2								5	
12	.	160690-13200	GASKET, MUFFLER	1								1	
13	..	160692-13520	MUFFLER ASSY	1								1	
I 13A	..	160692-13511	MUFFLER (A=FROM 1ST)	1								W 1	
I 13B	..	160692-13600	COVER, ELBOW (A=FROM 1ST)	1								W 1	
I 13C	..	114252-13950	BOLT M 6X 8 PLATED (A=FROM 1ST)	2								W 1	
14	.	160692-13530	COVER, MUFFLER	1								1	
I 15	.	160692-13750	DUCT, EXHAUST (A=EXXX)	1								W 1	
17	.	160692-13820	GASKET, TAIL PIPE	1								1	
18	.	160692-13850	SCREW M 5X 8	4								1	
19	.	114252-13950	BOLT M 6X 8 PLATED	5								1	
20	.	26106-080122	BOLT M 8X 12 PLATED	1								10	
21	.	26366-080002	NUT M 8	2								10	

----- REMARKS -----
 (予注) エンジンラベルに示された有効機番(9)のエンジンが指定されています。
 *タイメイパツノコウキチヤス。
 ENGINE IS INDICATED ON THE
 ENGINE LABEL WHICH IS SHOWN
 IN FIG.9.

5. CRANKSHAFT, PISTON & CAMSHAFT

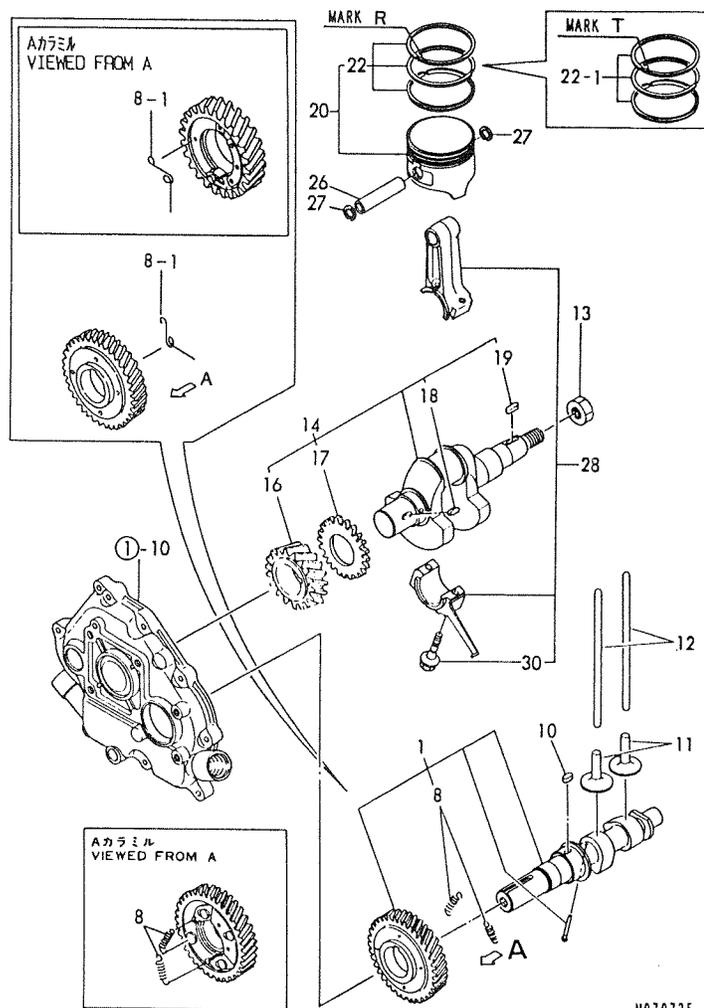

N070735

(REMARKS) "EFFECTIVE MACHINE NO." OF

ENGINE IS INDICATED ON THE ENGINE LABEL WHICH IS SHOWN IN FIG.9.

1807
1802
NPC-2437

5. CRANKSHAFT, PISTON & CAMSHAFT

98.03.18

(A)=GA180E-SKA (D)=
(B)= (E)=
(C)= (F)=

REF. NO.	LEV. 0	PART NO.	DESCRIPTION	Q'TY						I	P	U	A	R
				(A)	(B)	(C)	(D)	(E)	(F)					
1	.	160692-14051	CAMSHAFT ASSY	1										1
8	..	160690-14560	SPRING, DECOMP.	2										1
I 8-1	..	160690-14570	SPRING, DECOMP.	1							S			1
(A=E09080)														
I 10	.	22512-040120	KEY 4X 12	1										1
11	.	160490-14200	TAPPET	2										1
12	.	114250-14400	ROD, PUSH	2										1
13	.	160610-04910	NUT M14	1										1
14	.	760690-21702	CRANKSHAFT COMP	1										1
16	..	160690-21201	GEAR, CRANKSHAFT	1										1
17	..	160590-21210	GEAR, IDLE	1										1
18	..	22512-040120	KEY 4X 12	1										1
19	..	22512-040160	KEY 4X 16	1										1
20	.	160698-22010	PISTON W/RINGS	1										1
22	..	760698-22500	RING SET, PISTON	1										1
I 22-1	..	760698-22501	RING SET	1							S			1
(A=E14133)														
26	.	160690-22300	PIN, PISTON	1										1
27	.	22252-000160	CIRCLIP 16	2										10
28	.	760690-23700	ROD ASSY, CONNECTING	1										1
30	..	160710-23201	BOLT, ROD	2										2

REMARKS (チリク) エンジンラベル シリアルナンバーは、この図NO.9 (REMARKS) "EFFECTIVE MACHINE NO." OF

キタイメイハシラノコウキキテマス。

ENGINE IS INDICATED ON THE ENGINE LABEL WHICH IS SHOWN IN FIG.9.

6. FUEL OIL TANK & FUEL OIL LINE

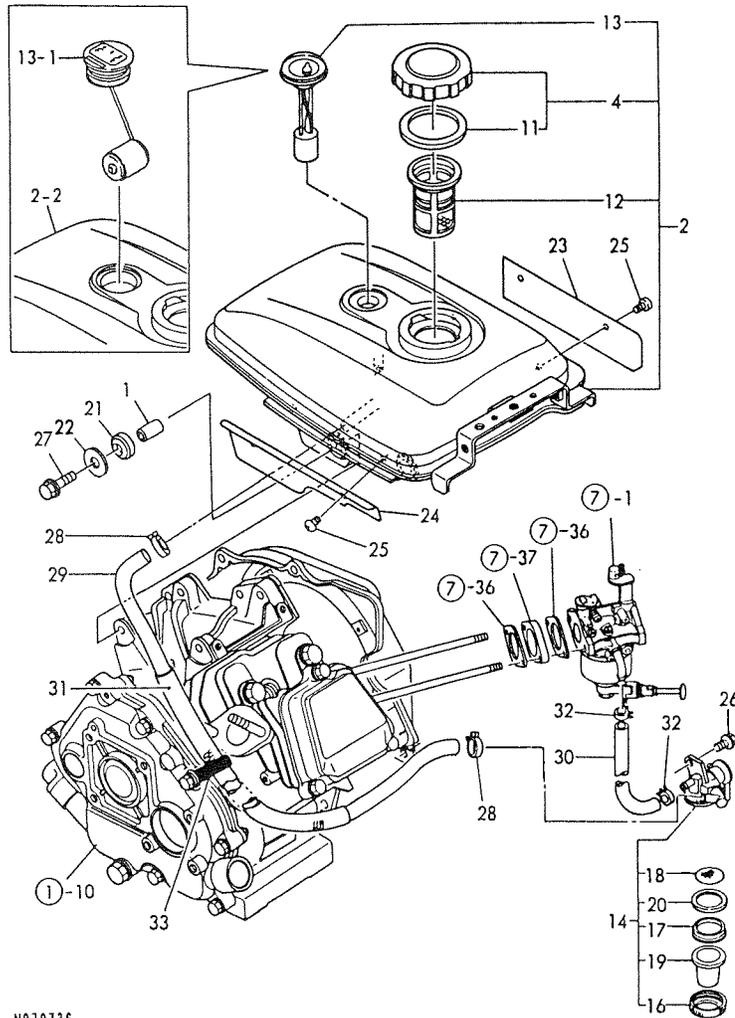

N070736

(1) INTERCHANGEABLE BY SIMULTANEOUS REPEACEMENT WITH NO.13-1.
(REMARKS)"EFFECTIVE MACHINE NO." OF

ENGINE IS INDICATED ON THE ENGINE LABEL WHICH IS SHOWN IN FIG.9.

6. FUEL OIL TANK & FUEL OIL LINE

1808
(1802)
NPC-2437

(A)=GA180E-SKA (D)=
(B)= (E)=
(C)= (F)=

REF. NO.	LEV. O	PART NO.	DESCRIPTION	-----Q'TY-----						I	P/U	A	R
				(A)	(B)	(C)	(D)	(E)	(F)				
1	.	114250-45310	COLLAR	4								1	
2	.	760698-55700	TANK ASSY, FUEL OIL	1								1	
2-1	.	760692-55720	TANK, FUEL (CREAM) (21)	1							S	1	
(A=E04319)													
I 2-2	.	760692-55721	TANK, FUEL (WHITE) (14)	1							F	1	(1
(A=E09563)													
I 2-3	.	760692-55722	TANK, FUEL (WHITE) (14)	1							N	1	
(A=E15106)													
4	..	160710-55061	CAP ASSY, FUEL TANK	1								1	
11	...	160393-55050	GASKET, TANK CAP	1								1	
12	..	160610-55100	STRAINER	1								1	
I 13	..	160792-55150	GAUGE, FUEL	1								1	
I 13-1	..	160792-55160	GAUGE, FUEL	1							S	1	(1
(A=E09563)													
14	.	160692-55300	COCK ASSY, FUEL	1								1	
16	..	160710-55360	RING	1								1	
17	..	160710-55370	GASKET	1								1	
18	..	160710-55381	STRAINER, FUEL	1								1	
I 18-1	..	160710-55382	FILTER	1							N	1	
(A=EXXX)													
19	..	160710-55390	BOWL, STRAINER	1								1	
I 20	..	160692-55421	PLATE	1							Z	1	
(A=EXXX)													
21	.	160690-55460	DAMPER, FUEL TANK	4								1	
22	.	160610-55470	PIECE	4								1	
23	.	160792-55900	GUIDE, F. TANK (RED:50)	1								1	
24	.	160792-55920	COVER, SIDE (RED) (50)	1								1	
25	.	160792-55950	SCREW 5X8, CRPHM.	4								1	
26	.	26106-060082	BOLT M 6X 8 PLATED	1								10	
I 26-1	.	26106-060102	BOLT M 6X 10 PLATED	1							N	10	
(A=EXXXXX)													
27	.	26476-060252	BOLT M 6X 25, TAPPING	4								10	
28	.	106990-44660	BAND, HOSE	2								1	
29	.	160692-59350	PIPE, FUEL OIL	1								1	
30	.	160820-59390	PIPE, FUEL	1								1	
31	.	160690-59400	PROTECTOR, PIPE	1								1	
32	.	124060-77680	CLAMP 10	2								5	
33	.	160710-78710	CLAMP, CORD	1								1	

REMARKS

(1) エタシNO.13-1 ト トウシ"コウカン ニシ コ"カンヒイ (1) INTERCHANGEABLE BY SIMULTANEOUS REPEACEMENT WITH NO.13-1.
アリ。 | (REMARKS)"EFFECTIVE MACHINE NO." OF

*タイメイ"ハシ"ノ コウキチ"ス。

ENGINE IS INDICATED ON THE ENGINE LABEL WHICH IS SHOWN IN FIG.9.

7. CARBURETOR

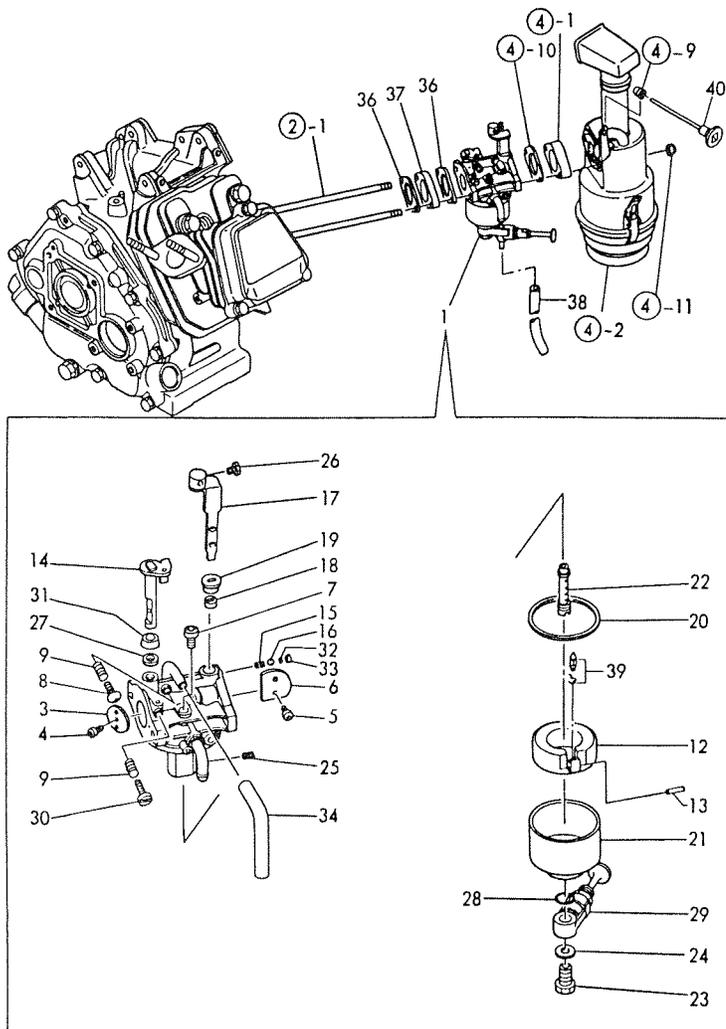

N070737

(1) REPAIR PART.
 (REMARKS)"EFFECTIVE MACHINE NO." OF
 ENGINE IS INDICATED ON THE
 ENGINE LABEL WHICH IS SHOWN
 IN FIG.9.

1B09
 (1B02)
 NPC-2437

7. CARBURETOR

98.03.18

(A)=GA180E-SKA (D)=
 (B)= (E)=
 (C)= (F)=

REF. NO.	LEV. 0	PART NO.	DESCRIPTION	Q'TY						I	P	U	A	R
				(A)	(B)	(C)	(D)	(E)	(F)					
1	.	160698-56020	CARBURETOR	1									1	
3	..	160698-56520	VALVE, THROTTLE	1									1	
I 4	..	160810-56670	SCREW	2									1	
5	..	160903-56670	SCREW	2									1	
6	..	160698-56530	VALVE, THROTTLE	1									1	
7	..	160698-56540	JET, PILOT	1									1	
8	..	160692-56710	SCREW	1									1	
9	..	181230-56380	SPRING	2									1	
12	..	160769-56620	FLOAT ASSY	1									1	
13	..	160610-56630	PIN, FLOAT	1									1	
14	..	160698-56550	SHAFT, THROTTLE	1									1	
15	..	160310-56980	SPRING, CHOKE	1									1	
16	..	160310-56990	BALL, STEEL	1									1	
17	..	160698-56560	LEVER, CHOKE	1									1	
18	..	160810-56580	RING, CHOKE SHAFT	1									1	
19	..	160810-56590	RING, CHOKE LEVER	1									1	
20	..	160610-56610	GASKET	1									1	
21	..	160592-56670	BODY, FLOAT CHAMBER	1									1	
22	..	160698-56570	NOZZLE, MAIN	1									1	
23	..	160692-56730	BOLT	1									1	
24	..	160802-56480	GASKET	1									1	
25	..	160698-56580	JET, MAIN	1									1	
26	..	26117-040088	BOLT M 4X 8 PLATED	1									10	
27	..	160640-56850	SEAL	1									1	
28	..	160692-56620	O-RING	1									1	
29	..	160692-56760	BODY, COCK	1									1	
30	..	160667-56750	SCREW, ADJUSTING	1									1	
31	..	160702-56720	RING	1									1	
32	..	160692-56800	SEAL, RUBBER	1									1	
33	..	160692-56700	SEAL, RUBBER	1									1	
34	..	160692-56770	HOSE	1									1	
36	.	160610-56150	GASKET, CARBURETOR	2									1	
37	.	160690-56160	SPACER	1									1	
38	.	23061-030180	HOSE D5/3	1									1	
39	.	160692-56560	VALVE, NEEDLE (RUBBER)	1									1	(1
40	.	160692-56900	ROD, CHOKE	1									1	

REMARKS
 (1) ホヨクフ^レヒンヂ^ス。(1) REPAIR PART.
 (チク) エンシ^ンフ^レシ^ツコ^ウキ ノ コク^モNO.9 ノ (REMARKS)"EFFECTIVE MACHINE NO." OF

*タイメイ^レハ^ンノ コク^モチ^ス.

ENGINE IS INDICATED ON THE
 ENGINE LABEL WHICH IS SHOWN
 IN FIG.9.

8. GOVERNOR & CONTROL DEVICE

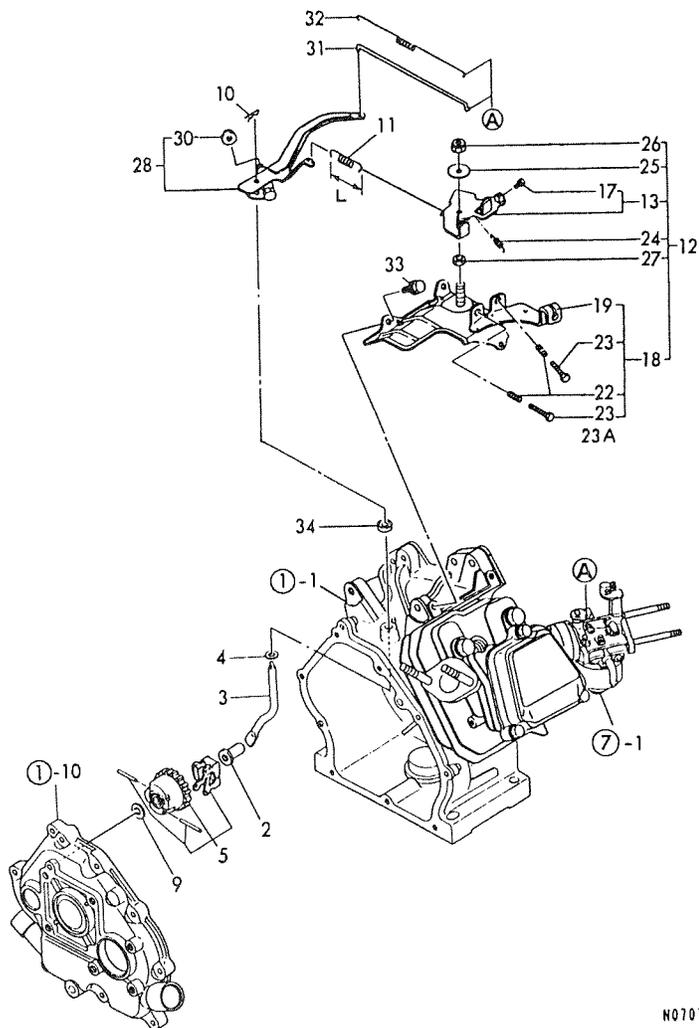

N070738

(1) L= REF.NO.11 46M/M, 11-1 44.5M/M.
(REMARKS)"EFFECTIVE MACHINE NO." OF

ENGINE IS INDICATED ON THE
ENGINE LABEL WHICH IS SHOWN
IN FIG.9.

8. GOVERNOR & CONTROL DEVICE

98.03.18

1810
(1802)
NPC-2437

(A)=GA180E-SKA (D)=
(B)= (E)=
(C)= (F)=

REF. NO.	LEV. O	PART NO.	DESCRIPTION	-----Q'TY-----						I	P/U	A	R
				(A)	(B)	(C)	(D)	(E)	(F)				
2	.	160690-61301	SPINDLE, GOVERNOR	1								1	
2-1	.	160690-61300 (A=E03172)	SPINDLE, GOVERNOR	1							N	1	
3	.	160690-61310	SHAFT, GOV. LEVER	1								1	
4	.	160690-61450	WASHER	1								1	
5	.	160690-61600	GEAR ASSY, GOV.	1								1	
9	.	160120-76940	WASHER	1								1	
10	.	22372-080000	SNAP PIN (JASO 8)	1								10	
11	.	160690-66010	SPRING, GOVERNOR	1								1	
I 11-1	.	160690-66011 (A=E15106)	SPRING, GOVERNOR	1							S	1	(1)
12	.	160692-66101	CONTROL ASSY	1								1	
13	..	160692-66051	LEVER ASSY, CONTROL	1								1	
17	...	26117-040088	BOLT M 4X 8 PLATED	1								10	
18	..	160690-66111	BASE ASSY, CONTROL	1								1	
19	...	160690-66140	BASE ASSY, CONTROL	1								1	
I 19-1	...	160690-66141 (A=E09080)	BASE, CONTROL	1							N	1	
I 19-2	...	160690-66142 (A=E14133)	BASE, CONTROL	1							N	1	
I 19-3	...	160690-66143 (A=E18100)	BASE, CONTROL	1							N	1	
22	...	160520-66291	SPRING	2								1	
23	...	26117-040257	BOLT M 4X 25	2								10	
I 23-1	...	26117-040257 (A=EXXX)	BOLT M 4X 25	1								K	10
I 23A	...	26117-040357 (A=EXXX)	BOLT M 4X 35	1								W	10
24	..	160664-66220	SPRING, RETURN	1								1	
25	..	160670-66350	COLLAR	1								1	
26	..	26347-060002	U-NUT 6	1								10	
27	..	26757-060002	LOCK NUT M 6 PLATED	1								10	
28	.	160690-66180	LEVER ASSY, GOVERNOR	1								1	
30	..	26366-060002	NUT M 6	1								10	
31	.	160690-66200	LINK, THROTTLE	1								1	
32	.	160690-66210	SPRING, TENSION	1								1	
33	.	26476-060142	BOLT M 6X 14, TAPPING	3								10	
I 34	.	114770-61600 (A=E09563)	SEAL, OIL	1							W	1	

REMARKS
(1) L= 329#NO.11 46#リ, 11-1 44.5#リ. (1) L= REF.NO.11 46M/M, 11-1 44.5M/M.
(チボク) エンジンがシマツコトウキ ハ コトクNO.9 / (REMARKS)"EFFECTIVE MACHINE NO." OF

*タイメイハシ / コウキチマシ.

ENGINE IS INDICATED ON THE
ENGINE LABEL WHICH IS SHOWN
IN FIG.9.

N070738

9. FLY.MAGNET & STARTING DEVICE

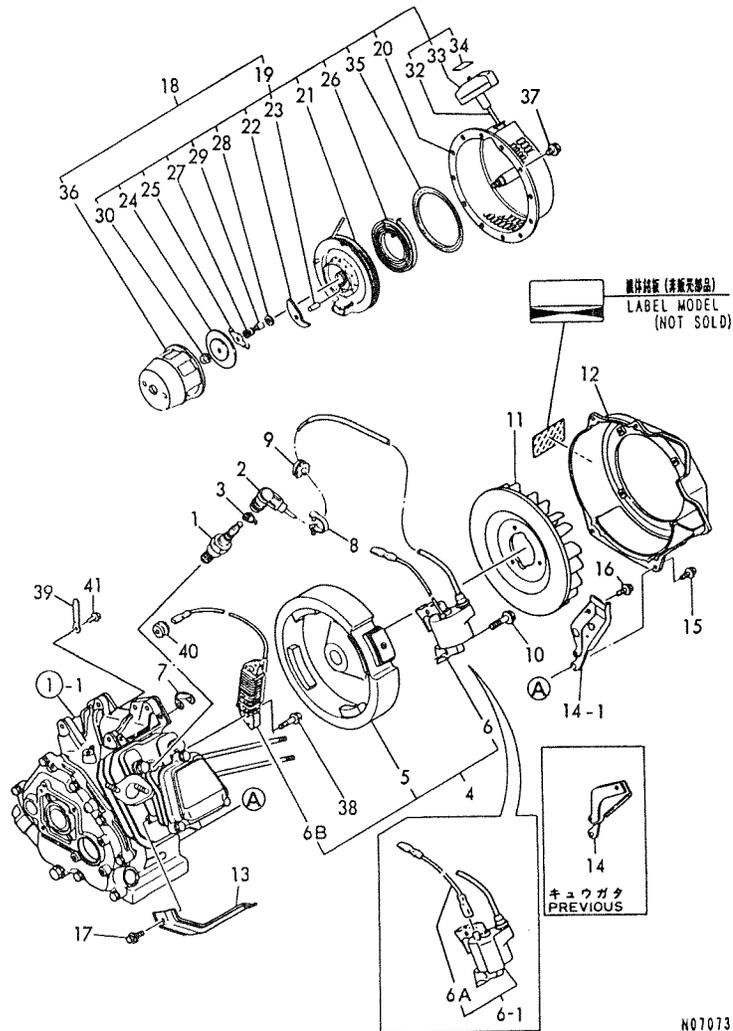

N070739

9. FLY.MAGNET & STARTING DEVICE

98.03.18

+-----+
| 1811 |
| (1802) |
+-----+
NPC-2437

(A)=GA180E-SKA (D)=
(B)= (E)=
(C)= (F)=

REF. NO.	LEV. 0	PART NO.	DESCRIPTION	-----Q'ITY-----						I	P	U	A	R
				(A)	(B)	(C)	(D)	(E)	(F)					
1	.	160690-78010	PLUG, SPARK	1									1	
I 1-1	.	160690-78020 (A=E14133)	PLUG, SPARK	1									N	1
2	.	160700-78040	CAP, PLUG	1										1
3	.	160700-78050	TERMINAL, PLUG	1										1
I 4	.	160693-78071	MAGNET ASSY, FLYWHEEL	1										1
I 5	..	160693-78510	ROTOR	1										1
I 6	..	160690-78531	COIL, IGNITION	1										1
I 6-1	..	160690-78532 (A=E05687)	IGNITER	1									N	1
I 6A	...	160690-78230 (A=EXXXXX)	CORD, STOP	1									W	1
I 6B	..	160693-78620 (A=EXXXXX)	COIL, LAMP	1									W	1
7	.	29610-000650	CLAMP, SPEED 065	1										1
8	.	29610-000950	CLAMP, SPEED 095	1										1
9	.	160700-78720	GROMMET	1										1
10	.	26476-060302	BOLT M 6X 30, TAPPING	2										10
11	.	160690-45011	FAN	1										1
I 11-1	.	160699-45010 (A=E23749)	FAN, COOLING	1									R	1
12	.	160692-45110	CASE, FAN (RED) (50)	1										1
13	.	160690-45200	COVER, CYLINDER	1										1
I 13-1	.	160699-45200	COVER, CYLINDER	1									R	1
14	.	160690-45210	COVER, REAR	1										1
I 14-1	.	160690-45211 (A=E03150)	COVER, REAR	1									S	1
I 14-2	.	160690-45211 (A=E14133)	COVER, REAR	1									Z	1
15	.	26476-060142	BOLT M 6X 14, TAPPING	4										10
I 16	.	26476-060142 (A=E14133)	BOLT M 6X 14, TAPPING	1									Z	10
17	.	26476-060142	BOLT M 6X 14, TAPPING	1										10
18	.	160690-76050	STARTER ASSY, RECOIL	1										1
I 18-1	.	160693-76050	STARTER ASSY, RECOIL	1									N	1
19	..	160690-76250 (A=E03150)	STARTER ASSY, RECOIL	1										1
I 19-1	..	160693-76250	STARTER ASSY, RECOIL	1									N	1
20	...	160690-76510 (A=E03150)	CASE, STARTER	1										1
I 20-1	...	160693-76510	CASE, STARTER	1									N	1
21	...	160690-76520 (A=E03150)	REEL	1										1
22	...	160690-76800	RATCHET	1										1
23	...	160690-76810	PIN, RATCHET	1										1
24	...	160690-76580	PLATE, FRICTION	1										1
25	...	160690-76530	GUIDE, RATCHET	1										1
26	...	160690-76540	SPRING, SPIRAL	1										1
27	...	160690-76560	SPRING, FRICTION	1										1
28	...	160690-76550	WASHER, THRUST	1										1
29	...	160690-76820	SHAFT	1										1
30	...	26367-060002	NUT M 6	1										30
32	...	160690-76630	ROPE, STARTER	1										1

** CONTINUE **

N070739

1. CYLINDER BLOCK

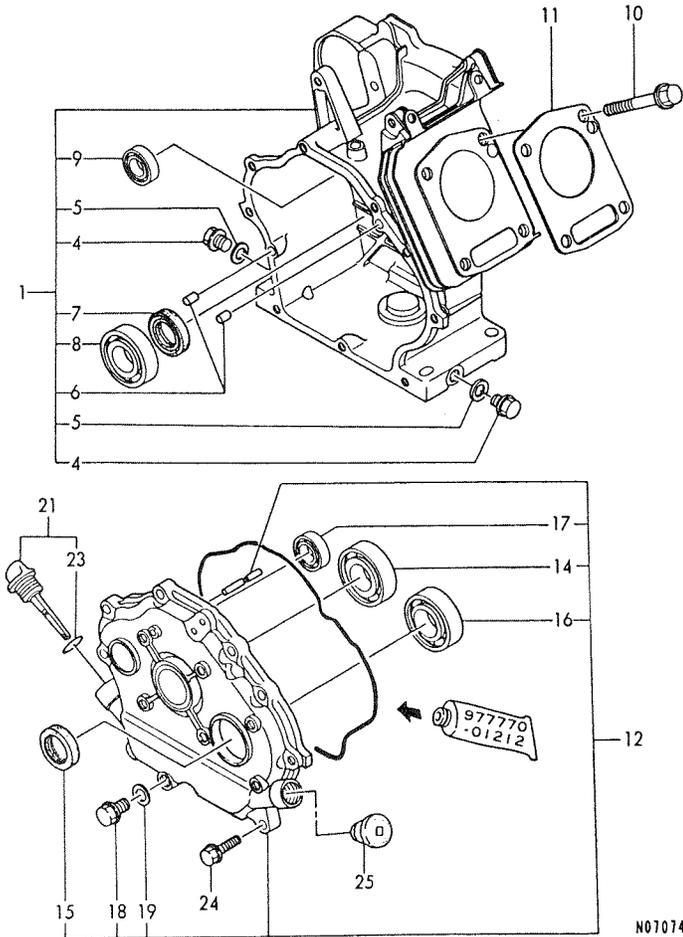

N070740

 (REMARKS) "EFFECTIVE MACHINE NO." OF
 ENGINE IS INDICATED ON THE
 ENGINE LABEL WHICH IS SHOWN
 IN FIG.6.

98.03.18

+-----+
 | 1C03 |
 | (1C02) |
 +-----+
 NPC-2438

1. CYLINDER BLOCK

(A)=GA220E-SKA (D)=
 (B)= (E)=
 (C)= (F)=

REF. NO.	LEV. 0	PART NO.	DESCRIPTION	-----Q'TY-----						I P/U A R
				(A)	(B)	(C)	(D)	(E)	(F)	
1	.	760790-01560	BLOCK ASSY, CYLINDER	1						1
4	..	160610-01690	PLUG, DRAIN	2						1
5	..	104200-59170	GASKET 12	2						5
6	..	22312-080120	PARALLEL PIN 8X12	2						10
I 6-1	..	114270-01600 (A=E36764)	PARALLEL PIN 8X12	2					R	1
7	..	160110-02220	SEAL, OIL	1						1
8	..	24101-062060	BALL BEARING	1						1
9	..	160903-28020	BALL BEARING	1						1
10	.	160890-01210	BOLT 10X 70	4						1
11	.	160790-01330	GASKET, CYL. HEAD	1						1
I 12	.	760792-01501	COVER, CRANKCASE	1						1
14	..	24101-062060	BALL BEARING	1						1
15	..	160110-02220	SEAL, OIL	1						1
16	..	24101-062060	BALL BEARING	1						1
17	..	160903-28020	BALL BEARING	1						1
18	..	160610-01690	PLUG, DRAIN	1						1
19	..	104200-59170	GASKET 12	1						5
21	.	160810-01740	CAP, W/LUB.OIL GAUGE	1						1
23	..	24311-000180	O-RING 1A P-18.0	1						10
24	.	26106-080302	BOLT M 8X 30 PLATED	9						10
25	.	160110-01870	PLUG, RUBBER W/SCREW	1						1

----- REMARKS -----
 (チキ) エンジンラベルにシリアルナンバーが記入されている。 (REMARKS) "EFFECTIVE MACHINE NO." OF

キタイメイハシラシのコンキテス。

ENGINE IS INDICATED ON THE
 ENGINE LABEL WHICH IS SHOWN
 IN FIG.6.

2. CYLINDER HEAD & BONNET

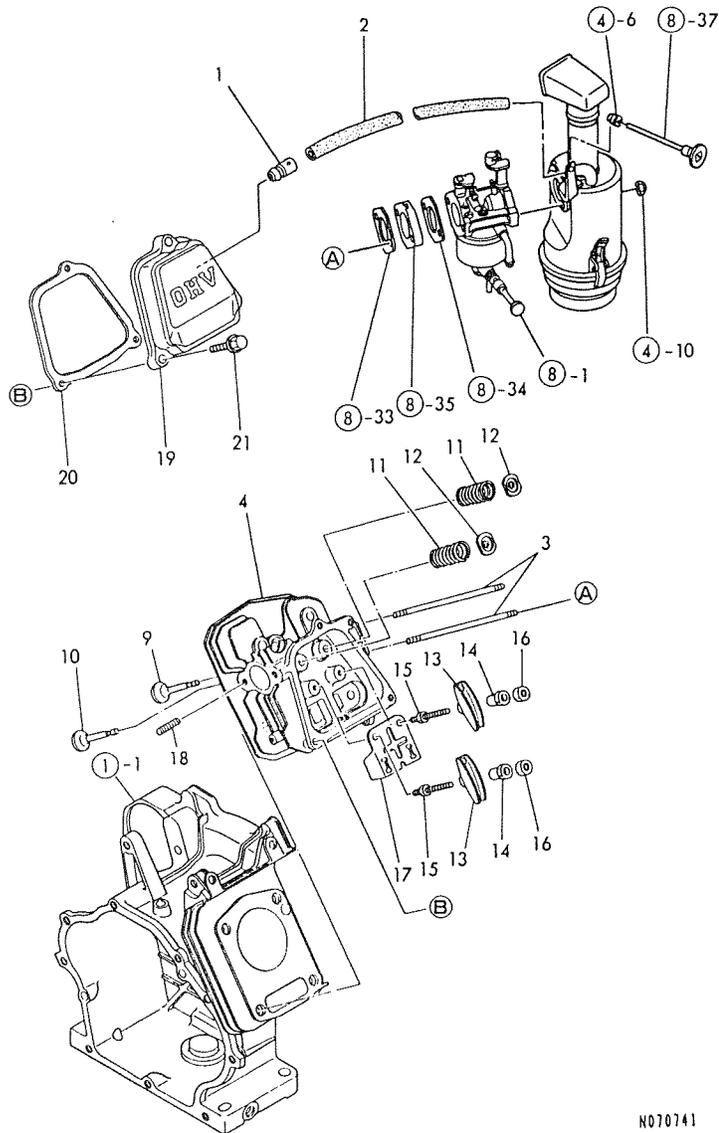

N070741

(1) REF.NO.12-1,13-1,14-1 & 15-2
INTERCHANGEABLE BY SET.
(REMARKS)"EFFECTIVE MACHINE NO." OF

ENGINE IS INDICATED ON THE
ENGINE LABEL WHICH IS SHOWN
IN FIG.6.

98.03.18

2. CYLINDER HEAD & BONNET

-----+
| 1C04 |
| (1C02) |
-----+
NPC-2438

(A)=GA220E-SKA (D)=
(B)= (E)=
(C)= (F)=

REF. NO.	LEV. 0	PART NO.	DESCRIPTION	-----Q'TY-----						I	P	U	A	R
				(A)	(B)	(C)	(D)	(E)	(F)					
1	.	160610-03050	BREATHER ASSY	1										1
2	.	160710-03190	PIPE, BREATHER	1										1
3	.	160792-04310	BOLT M 6X159	2										1
4	.	160790-11010	HEAD ASSY, CYLINDER	1										1
I 4-1	.	160790-11011	HEAD ASSY, CYLINDER	1								Q		1
(A=E44824)														
9	.	160790-11100	VALVE, INTAKE	1										1
10	.	160790-11110	VALVE, EXHAUST	1										1
11	.	160890-11120	SPRING, VALVE	2										1
12	.	160810-11180	RETAINER, SPRING	2										1
I 12-1	.	160890-11180	RETAINER, SPRING	2								F	1	(1
(A=E55017)														
13	.	160890-11200	ARM, ROCKER	2										1
I 13-1	.	160890-11202	ARM, ROCKER	2								F	1	(1
(A=E55017)														
14	.	160690-11220	PIVOT, ROCKER ARM	2										1
I 14-1	.	160690-11221	PIVOT,ROCKER ARM	2								F	1	(1
(A=E55017)														
15	.	160690-11270	BOLT	2										1
I 15-1	.	160690-11271	BOLT	2								N		1
(A=E25174)														
I 15-2	.	160890-11270	BOLT,ROCKER ARM	2								F	1	(1
(A=E55017)														
16	.	160690-11280	NUT M6X 0.5	2										1
17	.	160890-11290	PLATE, GUIDE	1										1
18	.	26216-080182	STUD M 8X 18 PLATED	2										10
19	.	160890-11300	BONNET	1										1
20	.	160890-11310	GASKET, BONNET	1										1
21	.	26106-060352	BOLT M 6X 35 PLATED	3										10

REMARKS

(1) エタシNO.12-1,13-1,14-1,15-2 セツト チ" | (1) REF.NO.12-1,13-1,14-1 & 15-2
コ"カンベイアリ。 | INTERCHANGEABLE BY SET.
(チ"ウ) エンシ"ンフ" シ"ハツシ"ウキ ハ コウモ"NO.6 ノ | (REMARKS)"EFFECTIVE MACHINE NO." OF

キタイメイ"ハ"ン ノ コ"ウキチ"ス。

ENGINE IS INDICATED ON THE
ENGINE LABEL WHICH IS SHOWN
IN FIG.6.

N070741

3. LABEL

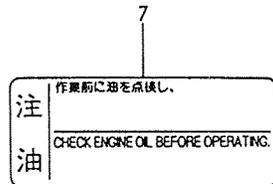
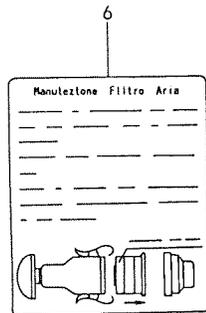
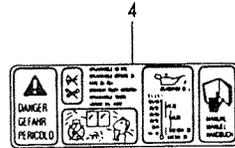

N070742

 (REMARKS) "EFFECTIVE MACHINE NO." OF
 ENGINE IS INDICATED ON THE
 ENGINE LABEL WHICH IS SHOWN
 IN FIG.6.

98.03.18

 1C05
 (1C02)

 NPC-2438

3. LABEL

(A)=GA220E-SKA (D)=
 (B)= (E)=
 (C)= (F)=

REF. NO.	LEV. 0	PART NO.	DESCRIPTION	-----Q'ITY-----						I	P	U	A	R
				(A)	(B)	(C)	(D)	(E)	(F)					
2	.	160798-07100	LABEL, FINGER START	1										1
4	.	160708-07260	MARK, CAUTION	1										1
5	.	160602-07370	LABEL, AIR CLEANER	1										1
6	.	160698-07350	LABEL	1								W		1
		(A=E16278)												
7	.	160692-07370	LABEL, AIR CLEANER	1								W		1
		(A=E16278)												

----- REMARKS -----
 (チリウ) エンジンノ シツゴウキ ノ コウキNO.6 ノ (REMARKS) "EFFECTIVE MACHINE NO." OF
 キタイメイハツ ノ コウキチニス。 ENGINE IS INDICATED ON THE
 ENGINE LABEL WHICH IS SHOWN
 IN FIG.6.

N070742

4. AIR CLEANER & MUFFLER

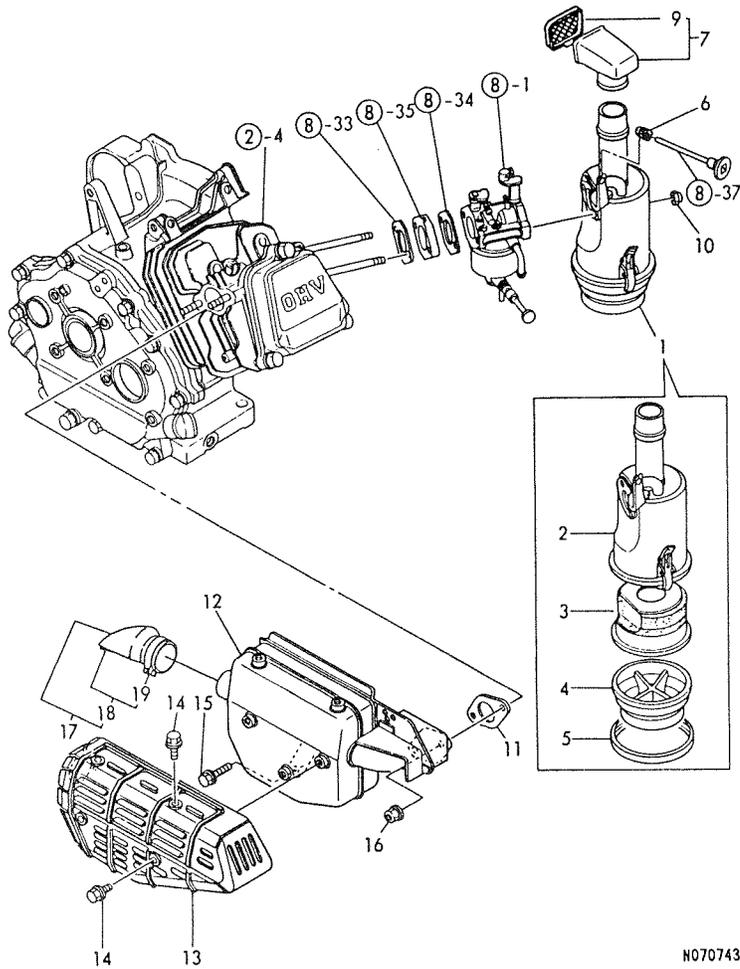

N070743

(REMARKS) "EFFECTIVE MACHINE NO." OF
ENGINE IS INDICATED ON THE
ENGINE LABEL WHICH IS SHOWN
IN FIG.6.

1C06
1C02
NPC-2438

4. AIR CLEANER & MUFFLER

98.03.18

(A)=GA220E-SKA (D)=
(B)= (E)=
(C)= (F)=

REF. NO.	LEV. 0	PART NO.	DESCRIPTION	Q'TY						I	P/U	A	R
				(A)	(B)	(C)	(D)	(E)	(F)				
1	.	160792-12500	CLEANER ASSY, AIR	1								1	
2	..	160792-12510	BODY, AIR CLEANER	1								1	
3	..	160792-12720	ELEMENT	1								1	
4	..	160820-12770	SUMP, OIL	1								1	
5	..	160792-12780	PIPE	1								1	
6	.	160763-12600	GROMMET, AIR CLEANER	1								1	
7	.	160792-12900	CAP, INTAKE	1								1	
9	..	160792-12920	NET	1								1	
10	.	26657-060002	CAP NUT M 6	2								5	
11	.	160890-13210	GASKET, MUFFLER	1								1	
12	.	160792-13500	MUFFLER	1								1	
12- 1	.	160792-13560	MUFFLER	1							S	1	
(A=E16278)													
13	.	160792-13530	COVER, MUFFLER	1								1	
14	.	114252-13950	BOLT M 6X 8 PLATED	5								1	
15	.	26106-080122	BOLT M 8X 12 PLATED	1								10	
16	.	26366-080002	NUT M 8	2								10	
17	.	114252-13800	PIPE ASSY, EXTERNAL	1							W	1	
(A=E16278)													
18	..	114252-13910	CLAMP	1								W	1
(A=E16278)													
19	...	114252-13960	SCREW 6X 25	1								W	1
(A=E16278)													

REMARKS
(チリウ) エンジンラベルに示された有効機番NO.6 / (REMARKS) "EFFECTIVE MACHINE NO." OF
*タイメイパシノ コウキチニス。 | ENGINE IS INDICATED ON THE
ENGINE LABEL WHICH IS SHOWN
IN FIG.6.

N070743

5. CRANKSHAFT, PISTON & CAMSHAFT

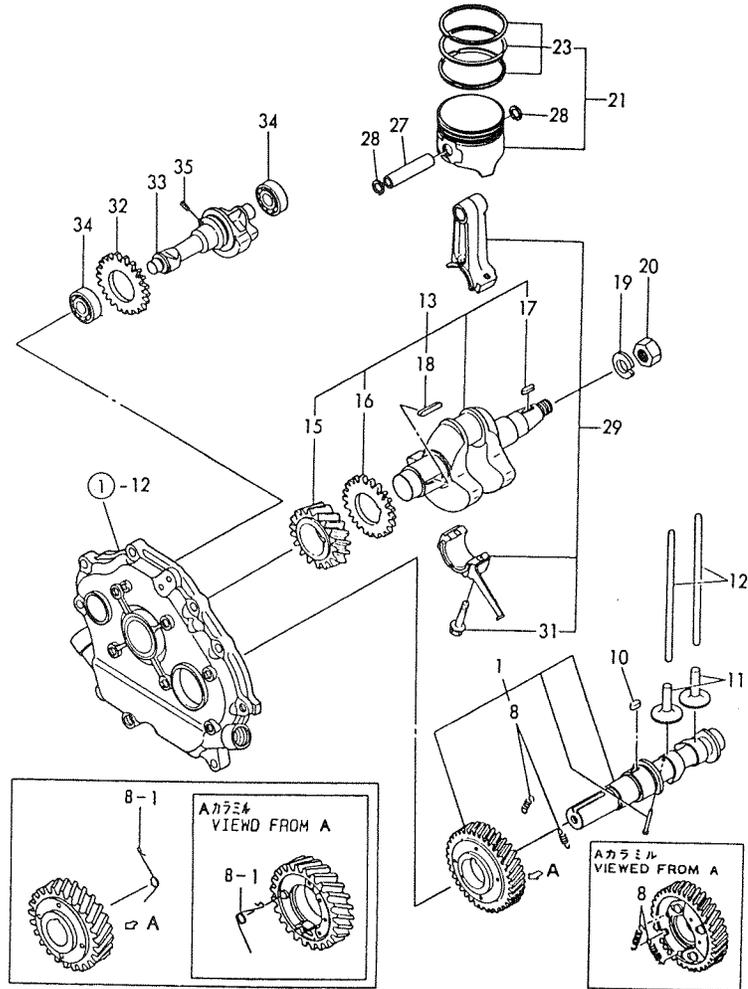

N070744

(REMARKS) "EFFECTIVE MACHINE NO." OF ENGINE IS INDICATED ON THE ENGINE LABEL WHICH IS SHOWN IN FIG.6.

1C07
1C02
NPC-2438

5. CRANKSHAFT, PISTON & CAMSHAFT

98.03.18

(A)=GA220E-SKA (D)=
(B)= (E)=
(C)= (F)=

REF. NO.	LEV. 0	PART NO.	DESCRIPTION	QTY						I	P	U	A	R
				(A)	(B)	(C)	(D)	(E)	(F)					
1	.	160890-14051	CAMSHAFT ASSY	1										1
8	..	160790-14560	SPRING, DECOMP.	2										1
I 8-1	..	160890-14560	SPRING, DECOMP.	1								S		1
(A=E24215)														
I 10	.	22512-050160	KEY 5X16, FEATHER	1										1
11	.	160890-14200	TAPPET	2										1
12	.	114250-14400	ROD, PUSH	2										1
13	.	760790-21700	CRANKSHAFT ASSY	1										1
15	..	160890-21200	GEAR, CRANKSHAFT	1										1
16	..	160890-21220	GEAR, BALANCER	1										1
17	..	22512-040160	KEY 4X 16	1										1
18	..	22512-040300	KEY 4X 30	1										1
19	.	22217-160000	SPRING WASHER 16	1										10
I 19-1	..	22137-160000	WASHER 16, POLISHED	1								N		10
(A=E24215)														
20	.	26737-160002	NUT M16	1										10
21	.	160790-22010	PISTON ASSY	1										1
21-1	.	160790-22011	PISTON W/RINGS	1								N		1
(A=E13422)														
23	..	760790-22500	RING SET, PISTON	1										1
23-1	..	760790-22501	RING SET, PISTON	1								S		1
(A=E13422)														
27	.	160890-22300	PIN, PISTON	1										1
28	..	22252-000190	CIRCLIP 19	2										10
29	.	760790-23700	ROD ASSY, CONNECTING	1										1
31	..	160810-23201	BOLT, ROD	2										2
32	.	160890-21220	GEAR, BALANCER	1										1
33	.	160790-28010	SHAFT, BALANCER	1										1
34	.	160903-28020	BALL BEARING	2										1
35	.	22351-040008	SPRING PIN 4X 8	1										10

REMARKS (非注) エンジンラベルにシリアルナンバーが記載されている。 (REMARKS) "EFFECTIVE MACHINE NO." OF

キタメイハシノコウキチス。

ENGINE IS INDICATED ON THE ENGINE LABEL WHICH IS SHOWN IN FIG.6.

6. FLY.MAGNET & STARTING DEVICE

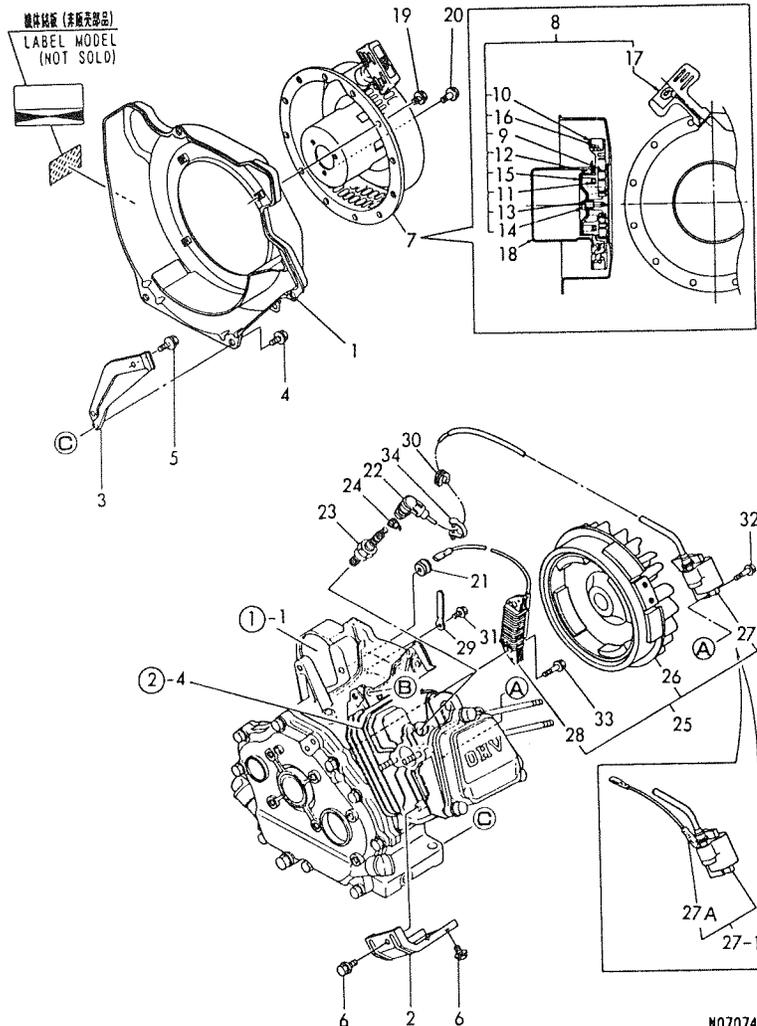

N070745

1C08
(1C02)
NPC-2438

6. FLY.MAGNET & STARTING DEVICE

98.03.18

(A)=GA220E-SKA (D)=
(B)= (E)=
(C)= (F)=

REF. NO.	LEV. 0	PART NO.	DESCRIPTION	Q'TY						I	P	U	A	R
				(A)	(B)	(C)	(D)	(E)	(F)					
1	.	160792-45110	CASE, FAN (RED) (50)	1										1
1-1	.	160790-45110	CASE, FAN (RED) (50)	1									N	1
		(A=E15459)												
2	.	160890-45200	HEAD COVER, SIDE	1										1
I 3	.	160790-45210	COVER, REAR	1									Z	1
		(A=E43701)												
4	.	26476-060142	BOLT M 6X 14, TAPPING	4										10
I 5	.	26476-060142	BOLT M 6X 14, TAPPING	1									Z	10
		(A=E43701)												
6	.	26476-060142	BOLT M 6X 14, TAPPING	2										10
7	.	160790-76050	STARTER ASSY, RECOIL	1										1
8	..	160890-76250	RECOIL ASSY	1										1
9	...	160890-76510	SPRING, SPIRAL	1										1
10	...	160890-76520	REEL	1										1
11	...	160890-76530	SPRING	1										1
12	...	160890-76540	DOG	1										1
13	...	160890-76550	SPRING, BRAKE	1										1
14	...	160641-76570	SCREW, CENTER	1										1
15	...	160890-76570	RETAINER	1										1
16	...	160890-76580	ROPE	1										1
17	...	160260-76620	KNOB, STARTER	1										1
18	..	160790-76590	PULLEY, STARTER	1										1
19	.	26106-060082	BOLT M 6X 8 PLATED	4										10
20	.	26106-060122	BOLT M 6X 12 PLATED	3										10
21	.	160341-01950	PIPE	1										1
21-1	.	160341-01950	PIPE	2									K	1
		(A=EXXXXX)												
22	.	160690-78010	PLUG, SPARK	1										1
I 22-1	.	160690-78020	PLUG, SPARK	1									N	1
		(A=E28250)												
23	.	160700-78040	CAP, PLUG	1										1
24	.	160700-78050	TERMINAL, PLUG	1										1
I 25	.	160792-78061	MAGNET ASSY, FLYWHEEL	1										1
I 26	..	160790-78500	ROTOR	1										1
I 27	..	160790-78511	COIL, IGNITION	1										1
I 27-1	..	160790-78512	IGNITER	1									R	1
		(A=E17795)												
I 27A	...	160690-78230	CORD, STOP	1										W
		(A=EXXXXX)												
I 28	..	160693-78620	COIL, LAMP	1										1
29	.	160710-78710	CLAMP, CORD	1										1
29-1	.	160710-78710	CLAMP, CORD	2									K	1
		(A=EXXXXX)												
30	.	160700-78720	GROMMET	1										1
31	.	26476-060142	BOLT M 6X 14, TAPPING	1										10
31-1	.	26476-060142	BOLT M 6X 14, TAPPING	2									K	10
		(A=EXXXXX)												
32	.	26476-060252	BOLT M 6X 25, TAPPING	2										10
33	.	26476-060252	BOLT M 6X 25, TAPPING	2										10
34	.	29610-000950	CLAMP, SPEED 095	1										1

7. FUEL OIL TANK & FUEL OIL LINE

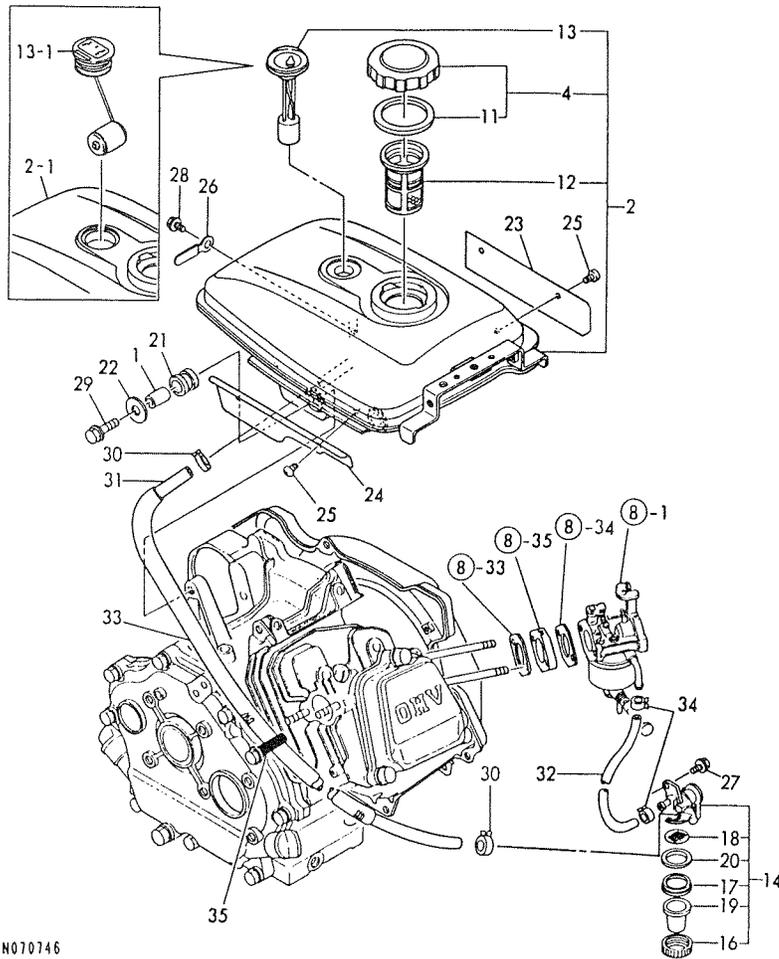

N070746

-----+
 | (1) INTERCHANGEABLE BY SIMULTANEOUS
 | REPEACEMENT WITH NO.13-1.
 | (REMARKS)"EFFECTIVE MACHINE NO." OF
 |
 | ENGINE IS INDICATED ON THE
 | ENGINE LABEL WHICH IS SHOWN
IN FIG.6.

98.03.18

7. FUEL OIL TANK & FUEL OIL LINE

-----+
 | 1C10 |
 | (1C02) |
 |-----+
 NPC-2438

(A)=GA220E-SKA (D)=
 (B)= (E)=
 (C)= (F)=

REF. NO.	LEV. 0	PART NO.	DESCRIPTION	-----Q'TY-----						I	P	U	A	R
				(A)	(B)	(C)	(D)	(E)	(F)					
1	.	114250-45310	COLLAR	4										1
2	.	760792-55720	TANK, FUEL (WHITE:14)	1										1
I 2- 1	.	760792-55701	TANK ASSY, FUEL	1								F	1	(1
		(A=E24734)												
I 2- 2	.	760792-55703	TANK, FUEL (WHITE) (14)	1								N	1	
		(A=E28807)												
4	..	160710-55061	CAP ASSY, FUEL TANK	1										1
11	...	160393-55050	GASKET, TANK CAP	1										1
12	..	160610-55100	STRAINER	1										1
I 13	..	160792-55150	GUAGE, FUEL	1										1
I 13- 1	..	160792-55160	GAUGE, FUEL	1								S	1	(1
		(A=E24734)												
14	.	160692-55300	COCK ASSY, FUEL	1										1
16	..	160710-55360	RING	1										1
17	..	160710-55370	GASKET	1										1
18	..	160710-55381	STRAINER, FUEL	1										1
I 18- 1	..	160710-55382	FILTER	1								N	1	
		(A=EXXX)												
19	..	160710-55390	BOWL, STRAINER	1										1
I 20	..	160692-55421	PLATE	1								Z	1	
		(A=EXXX)												
21	.	160690-55460	DAMPER, FUEL TANK	4										1
I 21- 1	.	160690-55461	DAMPER, FUEL TANK	4								N	1	
		(A=E46021)												
I 22	.	160610-55470	PIECE	4								Z	1	
		(A=E38094)												
23	.	160792-55900	GUIDE, F. TANK (RED:50)	1										1
24	.	160792-55920	COVER, SIDE (RED) (50)	1										1
25	.	160792-55950	SCREW 5X8, CRPHM.	4										1
26	.	160710-78710	CLAMP, CORD	1										1
27	.	26106-060082	BOLT M 6X 8 PLATED	1										10
I 27- 1	.	26106-060102	BOLT M 6X 10 PLATED	1								N	10	
		(A=EXXXXX)												
28	.	26106-060082	BOLT M 6X 8 PLATED	1										10
29	.	26476-060252	BOLT M 6X 25, TAPPING	4										10
I 29- 1	.	114370-45350	BOLT, FAN CASE	4								N	1	
		(A=E38094)												
I 29- 2	.	160690-55140	BOLT, FAN CASE	4								R	1	
		(A=E55017)												
30	.	106990-44660	BAND, HOSE	2										1
31	.	160792-59350	FUEL PIPE (A)	1										1
32	.	160792-59360	PIPE, FUEL	1										1
33	.	160792-59400	PIPE, PROTECTIVE	1										1
34	.	124060-77680	CLAMP 10	2										5
35	.	160820-78710	CLAMP, CORD	1										1

----- REMARKS -----+-----

(1) エタシNO.13-1 ト トウシコウカン ニチ コウカンセイ | (1) INTERCHANGEABLE BY SIMULTANEOUS
 アリ。 | REPEACEMENT WITH NO.13-1.
 (チゴ) エンジンノ シツシコウキ ハ コウモクNO.6 ノ | (REMARKS)"EFFECTIVE MACHINE NO." OF

キタイメイハシノ コウキチニス。

ENGINE IS INDICATED ON THE
 ENGINE LABEL WHICH IS SHOWN
 IN FIG.6.

8. CARBURETOR

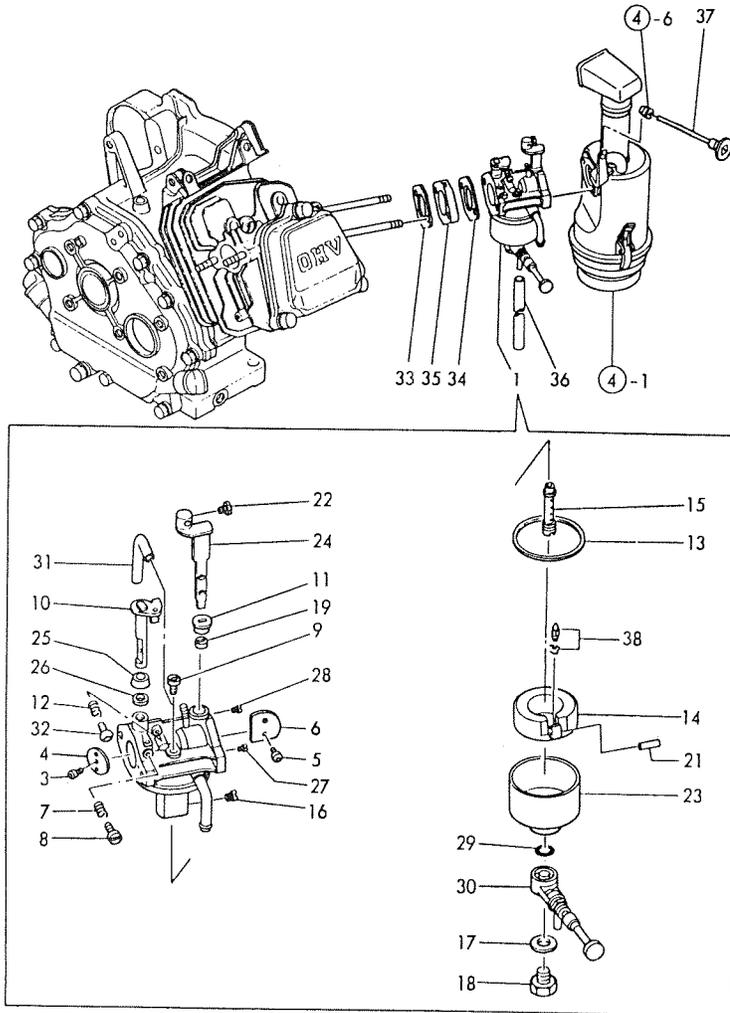

N070747

(1) REPAIR PART.
 (REMARKS) "EFFECTIVE MACHINE NO." OF
 ENGINE IS INDICATED ON THE
 ENGINE LABEL WHICH IS SHOWN
 IN FIG.6.

-----+
 | 1C11 |
 | (1C02) |
 +-----+
 NPC-2438

8. CARBURETOR

98.03.18
 (A)=GAZZOE-SKA (D)=
 (B)= (E)=
 (C)= (F)=

REF. NO.	LEV. 0	PART NO.	DESCRIPTION	-----Q'TY-----						I P/U A R
				(A)	(B)	(C)	(D)	(E)	(F)	
1	.	160792-56010	CARBURETOR ASSY	1						1
3	..	160120-56670	SCREW	2						1
4	..	160880-56761	VALVE, THROTTLE	1						1
5	..	160903-56670	SCREW	2						1
6	..	160792-56520	VALVE, CHOKE	1						1
7	..	181230-56380	SPRING	1						1
8	..	160667-56750	SCREW, ADJUSTING	1						1
9	..	160460-56940	JET, PILOT	1						1
10	..	160792-56530	SHAFT, THROTTLE	1						1
11	..	160792-56540	RING	1						1
12	..	160792-56550	SPRING	1						1
13	..	160210-56610	WASHER	1						1
14	..	160810-56620	FLOAT ASSY	1						1
15	..	160792-56560	NOZZLE, MAIN	1						1
16	..	160792-56570	JET, ENRICHMENT	1						1
17	..	160792-56580	GASKET	1						1
18	..	160792-56590	BOLT	1						1
19	..	160810-56580	RING, CHOKE SHAFT	1						1
21	..	160610-56630	PIN, FLOAT	1						1
22	..	26117-040088	BOLT M 4X 8 PLATED	1						10
23	..	160792-56430	BODY, FLOAT	1						1
24	..	160792-56600	GASKET	1						1
25	..	160702-56720	RING	1						1
26	..	160640-56850	SEAL	1						1
27	..	160792-56610	BOLT	1						1
28	..	160792-56620	JET, MAIN AIR	1						1
29	..	160692-56620	O-RING	1						1
30	..	160792-56630	BODY, CHAMBER	1						1
31	..	160692-56770	HOSE	1						1
32	..	160792-56640	SCREW	1						1
33	.	160790-56150	GASKET, CARBURETOR	1						1
34	.	160810-56150	GASKET, CARBURETOR	1						1
35	.	160790-56160	INSULATOR, CARBURETOR	1						1
36	.	160730-56880	HOSE D5/3	1						1
37	.	160692-56900	ROD, CHOKE	1						1
38	.	160792-56670	VALVE, NEEDLE (RUBBER)	1						1 (1

REMARKS
 (1) ホヨウフゝヒンヂゝス。
 (チユウ) エンジンラフゝ シゝツシコゝウキ ハ コゝモクNO.6 ノ
 *タイメイハゝンノ コゝウキヂゝス。
 (1) REPAIR PART.
 (REMARKS) "EFFECTIVE MACHINE NO." OF
 ENGINE IS INDICATED ON THE
 ENGINE LABEL WHICH IS SHOWN
 IN FIG.6.

9. GOVERNOR & CONTROL DEVICE

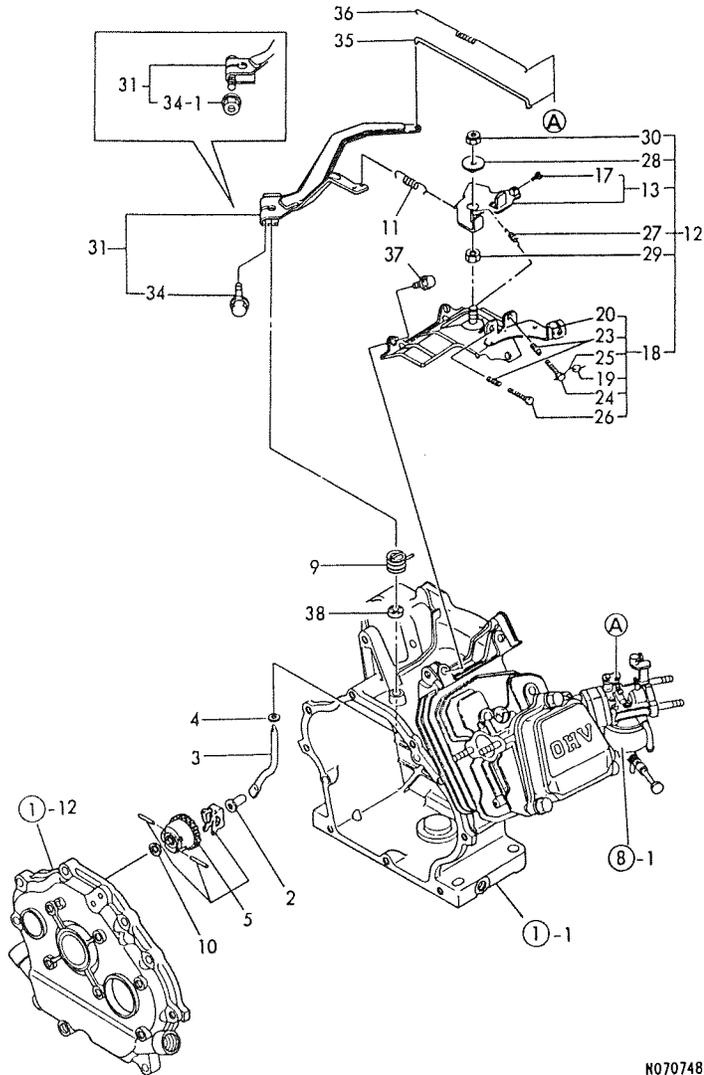

N070748

(REMARKS) "EFFECTIVE MACHINE NO." OF

ENGINE IS INDICATED ON THE ENGINE LABEL WHICH IS SHOWN IN FIG.6.

9. GOVERNOR & CONTROL DEVICE

98.03.18

1C12
(1C02)
NPC-2438

(A)=GA220E-SKA (D)=
(B)= (E)=
(C)= (F)=

REF. NO.	LEV. 0	PART NO.	DESCRIPTION	QTY						I	P/U	A	R
				(A)	(B)	(C)	(D)	(E)	(F)				
2	.	160690-61301	SPINDLE, GOVERNOR	1								1	
2-1	.	160690-61300 (A=E13422)	SPINDLE, GOVERNOR	1								N	1
I 2-2	.	160690-61301 (A=E43701)	SPINDLE, GOVERNOR	1								R	
3	.	160690-61310	SHAFT, GOV. LEVER	1									1
I 3-1	.	160690-61311 (A=E47056)	SHAFT, GOV. LEVER	1								R	1
4	.	160690-61450	WASHER	1									1
5	.	160690-61600	GEAR ASSY, GOV.	1									1
9	.	160890-66050	SPRING, RETURN	1									1
10	.	160120-76940	WASHER	1									1
11	.	160790-66010	SPRING, GOVERNOR	1									1
12	.	160792-66110	CONTROL ASSY	1									1
13	..	160692-66051	LEVER ASSY, CONTROL	1									1
17	...	26117-040088	BOLT M 4X 8 PLATED	1									10
18	..	160792-66120	BASE ASSY, CONTROL	1									1
19	...	135210-61090	LEAD	1									5
20	...	160890-66140	BASE, CONTROL	1									1
20-1	...	160890-66141 (A=E24215)	BASE, CONTROL	1								N	1
I 20-2	...	160890-66142 (A=E34063)	BASE, CONTROL	1								N	1
23	...	160520-66291	SPRING	2									1
24	...	160910-66440	BOLT	1									1
25	...	22451-060000	WIRE 0.6	1									10
26	...	26117-040257	BOLT M 4X 25	1									10
27	..	160664-66220	SPRING, RETURN	1									1
28	..	160670-66350	COLLAR	1									1
29	..	26347-060002	U-NUT 6	1									10
30	..	26757-060002	LOCK NUT M 6 PLATED	1									10
31	.	160890-66190	LEVER ASSY, GOVERNOR	1									1
34	..	26106-060252	BOLT M 6X 25 PLATED	1									10
I 34-1	..	26367-060002 (A=E39064)	NUT M 6	1								S	
I 34-2	..	26366-060002 (A=E43701)	NUT M 6	1								R	10
35	.	160690-66200	LINK, THROTTLE	1									1
36	.	160690-66210	SPRING, TENSION	1									1
37	.	26476-060142	BOLT M 6X 14, TAPPING	3									10
I 38	.	114770-61600 (A=E24734)	SEAL, OIL	1								W	1

REMARKS
(チリク) エンジンノ シヤツシヨクキ ノ コウキクNO.6 ノ (REMARKS) "EFFECTIVE MACHINE NO." OF

*タイメイハシノ コウキキチス。

ENGINE IS INDICATED ON THE ENGINE LABEL WHICH IS SHOWN IN FIG.6.

1. ENGINE MOUNTING & PULLEY

1003
1002
NPC-2436

1. ENGINE MOUNTING & PULLEY

98.03.18

(A)=YK682 (D)=
(B)=YK882 (E)=
(C)= (F)=

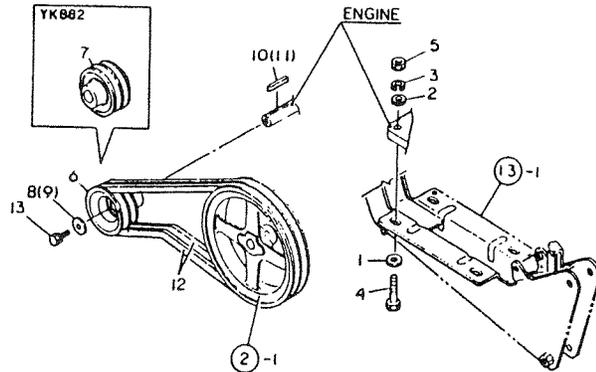

NO70439

REF. NO.	LEV. 0	PART NO.	DESCRIPTION	Q'ITY						I	P	U	A	R
				(A)	(B)	(C)	(D)	(E)	(F)					
1	.	1E4150-16060	WASHER	4	4									1
I 1-	1	1E6050-63110 (B=F030463)	COLLAR 10.5X28X3.2		4							N		2
2	.	22137-080000	WASHER 8, POLISHED	4	4									10
I 2-	1	22137-100000 (B=F030463)	WASHER 10, POLISHED		4							N		10
3	.	22217-080000	SPRING WASHER 8	4	4									10
I 3-	1	22217-100000 (B=F030463)	SPRING WASHER 10		4							N		10
4	.	26116-080402	BOLT M 8X 40 PLATED	4	4									10
I 4-	1	26206-100452 (B=F030463)	BOLT M10X45		4							N		10
5	.	26717-080002	NUT M 8	4	4									10
I 5-	1	26717-100002 (B=F030463)	NUT M10		4							N		10
6	.	1A2030-12000	PULLEY 75,ENGINE	1										1
7	.	1A2040-12000	PULLEY 75 2,ENGINE		1									1
8	.	1E6310-36190	WASHER 8.5X35X4.5		1									1
9	.	1A1040-43900	SPRING WASHER, ROD	1										1
I 9-	1	1E6020-25340 (A=F010208)	SPACER 9X28X4.5		1							R		1
10	.	22512-050300	KEY 5X 30	1										1
11	.	22512-070380	KEY 7X 38		1									1
12	.	25122-004201	V-BELT SP.A-42H	2	2									1
I 12-	1	1A2041-12010 (A=F010208) (B=F030336)	V BELT SA42	2	2							N		1
13	.	26013-080202	BOLT W/WASHER MBX20	1	1									10

2. MAIN PULLEY & TENSION

-----+
 1004
 (1002)
 -----+
 NPC-2436

2. MAIN PULLEY & TENSION

98.03.18

(A)=YK682 (D)=
 (B)=YK882 (E)=
 (C)= (F)=

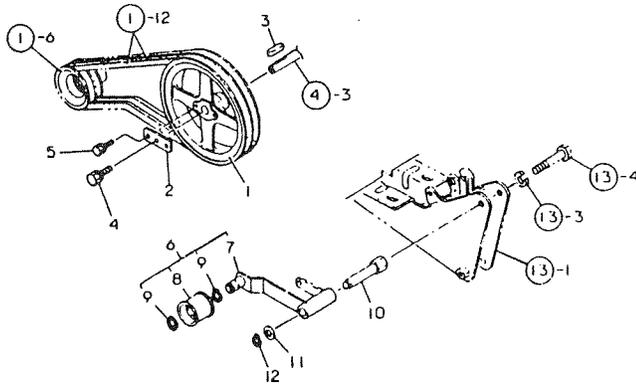

N070440

REF. NO.	LEV. 0	PART NO.	DESCRIPTION	-----Q'ITY-----						I	P/U	A	R
				(A)	(B)	(C)	(D)	(E)	(F)				
1	.	1A1510-10000	PULLEY 185, MN. SHAFT	1	1							1	
2	.	1A1470-10040	CLAMP SEAT, PULLEY	1	1							1	
3	.	1E4070-79020	KEY 5X5X30	1	1							2	
I 3-	1	22512-050300 (B=F030588)	KEY 5X 30			1					N	1	
4	.	26013-080202	BOLT W/WASHER M8X20	1	1							10	
5	.	26016-060124	BOLT 6X12 W/L.W.	2	2							30	
6	.	1A2040-13000	TENSION COMPL.	1	1							1	
7	..	1A2040-13010	ARM COMP., TENSION	1	1							1	
8	..	1A1220-64200	ROLLER, TENSION	1	1							1	
9	..	22242-000150	CIRCLIP 15	2	2							10	
10	.	1A2040-13100	NUT, TENSION	1	1							1	
11	.	22117-120000	WASHER 12	1	1							10	
12	.	22242-000120	CIRCLIP 12	1	1							10	

3. TRANSMISSION CASE

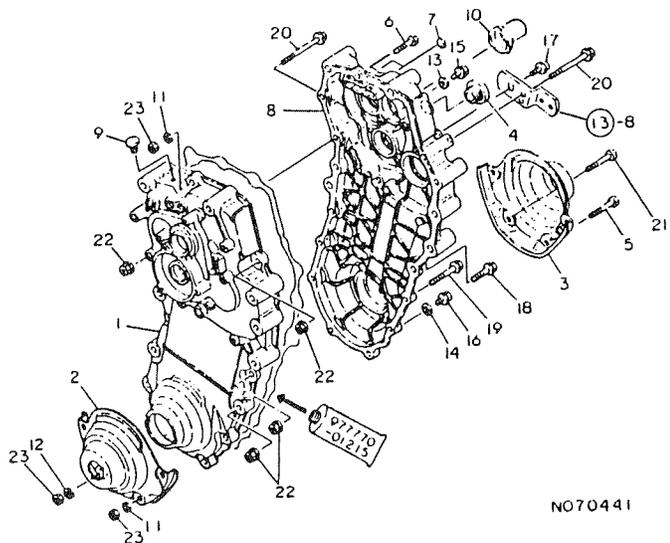

↑*P/# 7A2049-21000, TRANSMISSION ASSY.

-----+
 | 1006 |
 | (1D05) |
 +-----+
 NPC-2436

3. TRANSMISSION CASE

(A)=YK682 (D)=
 (B)=YK882 (E)=
 (C)= (F)=

98.03.18

REF. NO.	LEV. 0	PART NO.	DESCRIPTION	-----Q'TY-----						I	P/U	A	R
				(A)	(B)	(C)	(D)	(E)	(F)				
1	.	1A1560-20001	CASE L, TRANSMISSION	1	1							1	
I 1-	1	1A1560-20002	CASE L, TRANSMISSION	1	1						N	1	
		(A=F010306) (B=F030413)											
2	.	1A1490-20050	COVER L, PROTECTIVE	1	1							1	
3	.	1A1490-20070	COVER R, PROTECTIVE	1	1							1	
4	.	1A1470-20090	CAP 35, OIL FILLER	1	1							1	
5	.	1A1490-20610	REAMER BOLT 8X45	1	1							1	
6	.	1A1470-20620	REAMER BOLT 8X35	1	1							1	
7	.	1A1470-20940	CAP 16	2	2							1	
8	.	1A1560-20011	CASE R, TRANSMISSION	1	1							1	
I 8-	1	1A1560-20012	CASE R, TRANSMISSION	1	1						N	1	
		(A=F010306) (B=F030413)											
9	.	1A1070-28160	BREATHER 10	1	1							1	
10	.	1A1220-28290	CAP, P.T.O.	1	1							1	
11	.	22217-080000	SPRING WASHER 8	2	2							10	
12	.	22217-080000	SPRING WASHER 8	3	3							10	
13	.	23414-060000	GASKET 6, ROUND	1	1							10	
14	.	23414-080000	GASKET 8, ROUND	1	1							10	
15	.	26107-060122	BOLT M 6X 12 PLATED	1	1							30	
16	.	26107-080122	BOLT M 8X 12 PLATED	1	1							5	
17	.	26107-080162	BOLT M 8X 16 PLATED	1	1							5	
18	.	26107-080302	BOLT M 8X 30 PLATED	2	2							5	
19	.	26107-080502	BOLT M 8X 50 PLATED	1	1							10	
20	.	26107-080802	BOLT M 8X 80 PLATED	2	2							2	
21	.	26116-080452	BOLT M 8X 45 PLATED	3	3							10	
22	.	26367-080002	U-NUT M 8	5	5							10	
23	.	26717-080002	NUT M 8	5	5							10	

----- REMARKS -----
 * 7A2049-21000 ミツシヨン(シ) ↑*P/# 7A2049-21000, TRANSMISSION ASSY.

4. MAIN & COUNTER SHAFTS

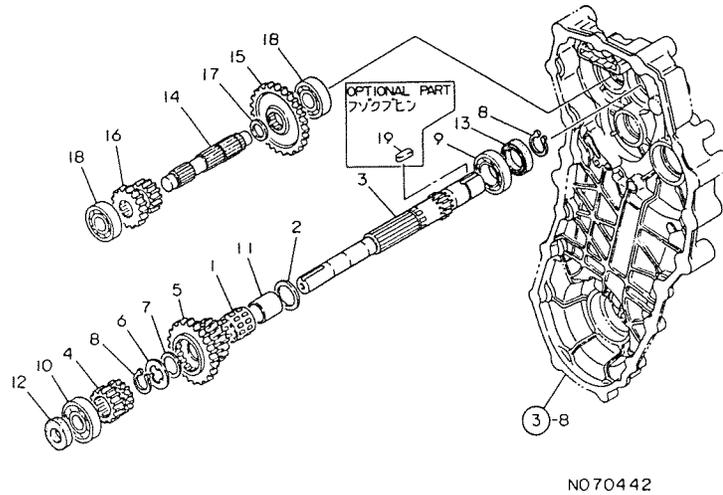

(1) IT IS AN ATTACHED PART.

+-----+
| 1007 |
| (1005) |
+-----+
NPC-2436

4. MAIN & COUNTER SHAFTS

98.03.18

(A)=YK682 (D)=
(B)=YK882 (E)=
(C)= (F)=

REF. NO.	LEV. 0	PART NO.	DESCRIPTION	-----Q'TY-----						I	P/U	A	R
				(A)	(B)	(C)	(D)	(E)	(F)				
1	.	1A1490-20180	NEEDLE K253026	1	1							1	
2	.	1A1490-20191	WASHER 20X36X1.6	1	1							1	
3	.	1A1499-23000	SHAFT,MAIN	1	1							1	
I 4	- 1 .	1A2040-23010 1A2040-23011 (B=F030588)	GEAR 13 GEAR 13	1	1							1 N 0	
5	.	1A2040-23030	GEAR 24X31	1	1							1	
6	.	1A2040-23050	WASHER 27.5,TARUST	1	1							1	
7	.	1A2040-23060	LINER 20X27.5X1	1	1							1	
8	.	22242-000200	CIRCLIP 20	2	2							10	
9	.	24101-062044	BALL BEARING	1	1							1	
10	.	24101-063034	BALL BEARING	1	1							1	
11	.	24163-205265	COLLAR 20X25X26.5	1	1							1	
12	.	24421-173208	SEAL TC17.32 08, OIL	1	1							1	
13	.	24421-203508	SEAL TC20 35 08, OIL	1	1							1	
14	.	1A1490-20201	SHAFT,COUNTER	1	1							1	
15	.	1A1490-20210	GEAR 36	1	1							1	
16	.	1A1510-20221	GEAR 19X15	1	1							1	
I 16	- 1 .	1A1510-20222 (B=F030588)	GEAR 19X15			1						N 0	
17	.	1A1120-43600	LINER 20X25X1	1	1							1	
18	.	24101-062034	BALL BEARING	2	2							1	
19	.	22550-050201 (A=F010036) (B=F010058)	KEY 5X20	1	1							W 1 (1	

REMARKS (1)フソクフヒン (1) IT IS AN ATTACHED PART.

5. BRAKE SHAFT & REDUCTION SHAFT

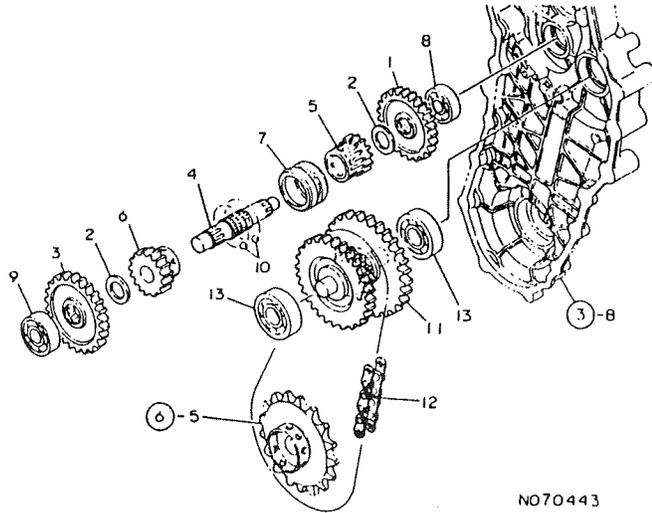

1008
(1005)
NPC-2436

5. BRAKE SHAFT & REDUCTION SHAFT

98.03.18

(A)=YK682 (D)=
(B)=YK882 (E)=
(C)= (F)=

REF. NO.	LEV. 0	PART NO.	DESCRIPTION	-----Q'ITY-----						I	P/U	A	R
				(A)	(B)	(C)	(D)	(E)	(F)				
1	.	1A1490-20310	GEAR 33	1	1							1	
2	.	1A1105-23200	LINER 30X20.2X1	2	2							1	
3	.	1A2040-23210	GEAR 44	1	1							1	
4	.	1A1811-23600	SHAFT, INTERMEDIATE	1	1							1	
5	.	1A1811-23620	GEAR 13, BALL CLUTCH	1	1							1	
6	.	1A1811-23630	GEAR 18	1	1							1	
7	.	1A1811-23640	DOG 18X13	1	1							1	
I 7- 1	.	1A1811-23641 (B=F030588)	DOG 18X13		1							N	0
I 7- 2	.	1A1811-23642 (B=F030613)	DOG 18X13		1							N	0
8	.	24101-063024	BALL BEARING	1	1							1	
9	.	24101-063034	BALL BEARING	1	1							1	
10	.	24190-070001	BALL 7/32	12	12							5	
11	.	1A2049-20400	SHAFT COMPL, FINAL	1	1							1	
12	.	1A1560-24200	CHAIN 3/4X46	1	1							1	
13	.	24101-063044	BALL BEARING	2	2							1	

6. AXLE

+-----+
 | 1D09 |
 | (1D05) |
 +-----+
 NPC-2436

6. AXLE

98.03.18

(A)=YK682 (D)=
 (B)=YK882 (E)=
 (C)= (F)=

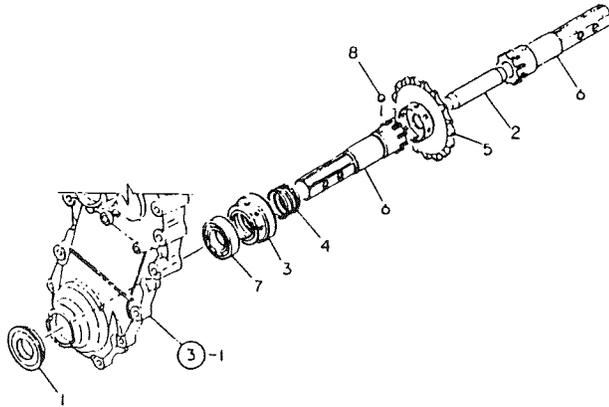

N070444

REF. NO.	LEV. 0	PART NO.	DESCRIPTION	-----Q'TY-----						I	P/U	A	R
				(A)	(B)	(C)	(D)	(E)	(F)				
1	.	1A1470-20530	OIL SEAL 305212	2	2							1	
2	.	1A1470-20560	CORE, AXLE	1	1							1	
3	.	1A1470-20570	SHIFTER	2	2							1	
4	.	1A1470-20580	SPRING 41.2X26	2	2							1	
5	.	1A1490-20590	SPROCKET 17, AXLE	1	1							1	
6	.	1A2049-24000	AXLE	2	2							1	
7	.	24101-062064	BALL BEARING	2	2							1	
8	.	24190-100001	BALL 5/16, STEEL	18	18							1	

7. MAIN & SUB- CHANGES

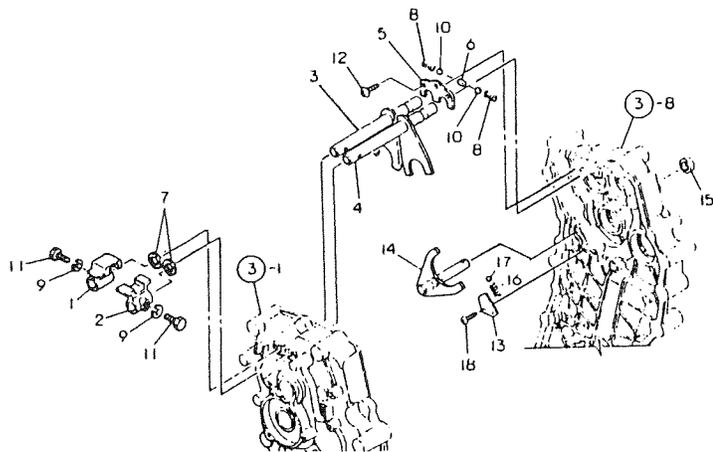

N070445

+-----+
 | 1D10 |
 | (1D05) |
 +-----+
 NPC-2436

7. MAIN & SUB- CHANGES

(A)=YK682 (D)=
 (B)=YK882 (E)=
 (C)= (F)=

98.03.18

REF. NO.	LEV. 0	PART NO.	DESCRIPTION	-----Q'TY-----						I	P/U	A	R
				(A)	(B)	(C)	(D)	(E)	(F)				
1	.	1A1470-20832	BRACKET A,CHG.LEVER	1	1							1	
2	.	1A1470-20842	BRACKET	1	1							1	
3	.	1A1490-20853	SHAFT A COMPL.,FORK	1	1							1	
4	.	1A1490-20883	SHAFT B COMPL.,FORK	1	1							1	
5	.	1A1490-20950	RETNR.PLATE A,BALL	1	1							1	
6	.	1A1105-27050	PIN,CHG.FORK SHAFT	1	1							2	
7	.	1A1104-28230	OIL SEAL 12184	2	2							2	
8	.	1E6150-56040	SPRING	2	2							1	
9	.	22217-060000	SPRING WASHER 6	2	2							10	
10	.	24190-100001	BALL 5/16, STEEL	2	2							1	
11	.	26117-060142	BOLT M 6X 14 PLATED	2	2							10	
12	.	26476-060142	BOLT M 6X 14,TAPPING	3	3							10	
13	.	1A1490-20960	RETNR.PLATE B,BALL	1	1							1	
14	.	1A2049-27100	SHAFT C COMP.,FORK	1	1							1	
I 14-	1	1A2049-27101	SHAFT C COMP.,FORK			1					N	0	
		(B=F030613)											
15	.	1A1104-28230	OIL SEAL 12184	1	1							2	
16	.	1E6150-56040	SPRING	1	1							1	
17	.	24190-100001	BALL 5/16, STEEL	1	1							1	
18	.	26476-060142	BOLT M 6X 14,TAPPING	2	2							10	

8. SIDE CLUTCH

+-----+
| 1011 |
| (1005) |
+-----+
NPC-2436

8. SIDE CLUTCH

98.03.18

(A)=YK682 (D)=
(B)=YK882 (E)=
(C)= (F)=

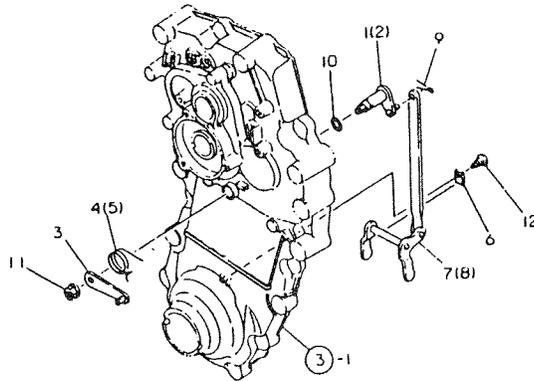

N070446

REF. NO.	LEV. 0	PART NO.	DESCRIPTION	-----Q'ITY-----						I	P/U	A	R
				(A)	(B)	(C)	(D)	(E)	(F)				
1	.	1A1490-20751	SHAFT L CMP,SD.CLTCH	1	1							1	
2	.	1A1490-20761	SHAFT R CMP,SD.CLTCH	1	1							1	
3	.	1A1105-24490	PLATE,CLTCH.OUTR.ARM	2	2							2	
I 3-	1	1A2050-24500 (B=F030588)	ARM, CLUTCH		2						N	0	
4	.	1A1580-26030	SPRING 20.5 L,TORQUE	1	1							1	
5	.	1A1580-26040	SPRING 20.5 R,TORQUE	1	1							1	
6	.	1E4440-26200	RETAINER,SIDE CLUTCH	2	2							1	
7	.	1A1811-27250	FORK L CMP.,SD.CLTCH	1	1							1	
8	.	1A1811-27300	FORK R CMP.,SD.CLTCH	1	1							1	
9	.	22417-200120	COTTER PIN 2.0X12	2	2							10	
10	.	24311-000100	O-RING 1A P-10.0	2	2							10	
11	.	26367-080002	U-NUT M 8	2	2							10	
12	.	26476-060142	BOLT M 6X 14,TAPPING	2	2							10	

9. FENDER

+-----+
 | 1013 |
 | (1012) |
 +-----+
 NPC-2436

9. FENDER

98.03.18

(A)=YK682 (D)=
 (B)=YK882 (E)=
 (C)= (F)=

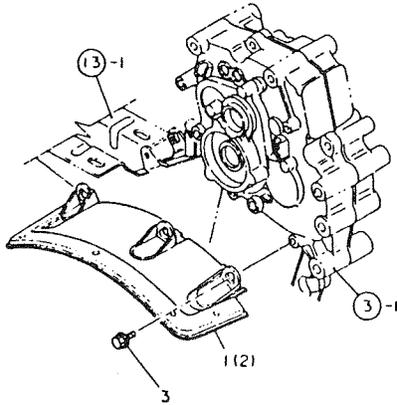

N070447

REF. NO.	LEV. 0	PART NO.	DESCRIPTION	-----Q'TY-----						I	P/U	A	R
				(A)	(B)	(C)	(D)	(E)	(F)				
1	.	1A2040-32100-1	FENDER L COMPL.	1	1							0	
I 2	.	7A2049-32110	FENDER R PLAS.	1	1							0	
3	.	26107-080122	BOLT M 8X 12 PLATED	6	6							5	

20. TIRE(ADDITIONAL ITEM)

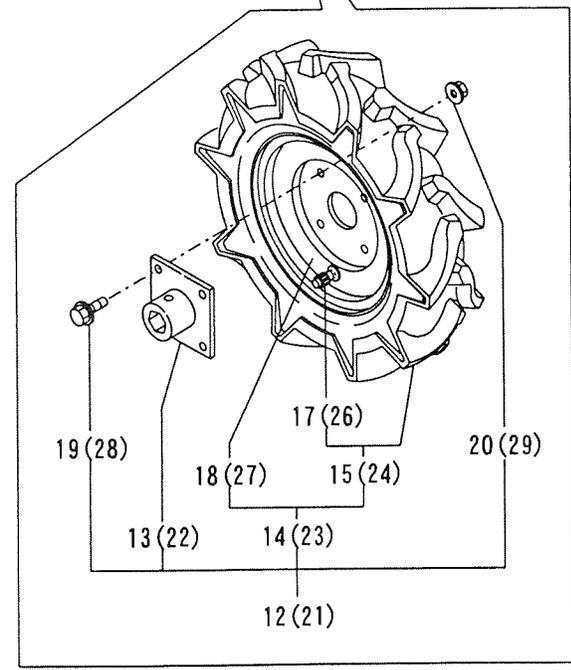
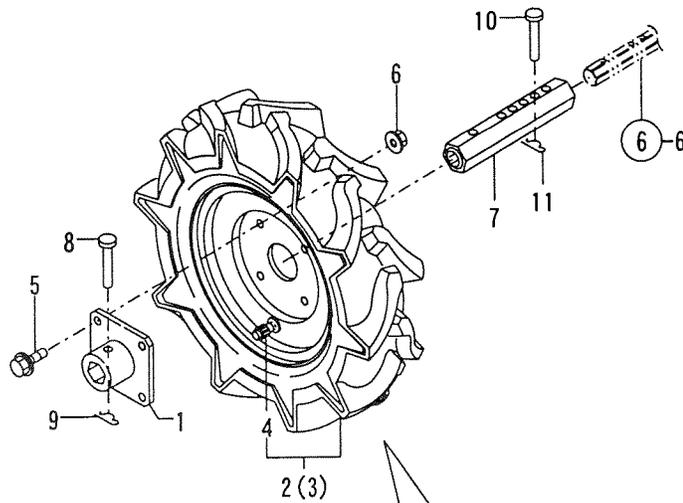

N077430

(1) IT IS AN EXCLUSIVE PART FOR THE YK882G.

98.03.18

1014
(1012)
NPC-2436

20. TIRE(ADDITIONAL ITEM)

(A)=YK682 (D)=
(B)=YK882 (E)=
(C)= (F)=

REF. NO.	LEV. 0	PART NO.	DESCRIPTION	Q'TY						I	P/U	A	R
				(A)	(B)	(C)	(D)	(E)	(F)				
1	.	1A2049-30140	FLANGE COMP.,WHEEL	1							1	(1	
I 1-	1	1A2049-30141	FLANGE COMP.,WHEEL	1							R	0	
		(B=F030613)											
2	.	1A2040-31310	TIRE L W/WHEEL	1							1	(1	
3	.	1A2040-31360	TIRE W/WHEEL R	1							1	(1	
4	..	1A2040-31090	VALVE TR412	2							1	(1	
5	.	26107-080182	BOLT M 8X 18 PLATED	8							5	(1	
6	.	26367-080002	U-NUT M 8	8							10	(1	
7	.	1A1590-34350	PIPE,AXLE	2							1	(1	
8	.	1E4030-35031	PIN 10X65,AXLE	2							1	(1	
9	.	1A1290-36010	SNAP PIN 10	2							5	(1	
10	.	1A1400-36050	PIN 8X55,AXLE	2							1	(1	
11	.	22360-080000	SNAP PIN 8	2							10	(1	
I 12	.	1A2049-31300	TIRE L(FRANGE	1							0	(1	
I 13	..	1A2049-30141	FLANGE COMP.,WHEEL	1							0	(1	
I 14	..	1A2040-31310	TIRE L W/WHEEL	1							1	(1	
I 15	...	1A2040-31050	TIRE 4.00-8 W/O WHL.	1							1	(1	
I 17	1A2040-31090	VALVE TR412	1							1	(1	
I 18	...	1A2040-31100	WHEEL 4.00-8	1							1	(1	
I 19	...	26107-080182	BOLT M8X18 PLATED	4							0	(1	
I 20	..	26367-080002	U-NUT M8	4							1	(1	
I 21	.	1A2049-31350	TIRE R(FRANGE	1							0	(1	
I 22	..	1A2049-30141	FLANGE COMP.,WHEEL	1							0	(1	
I 23	..	1A2040-31360	TIRE W/WHEEL R	1							1	(1	
I 24	...	1A2040-31050	TIRE 4.00-8 W/O WHL.	1							1	(1	
I 26	1A2040-31090	VALVE TR412	1							1	(1	
I 27	...	1A2040-31100	WHEEL 4.00-8	1							1	(1	
I 28	..	26107-080182	BOLT M8X18 PLATED	4							0	(1	
I 29	..	26367-080002	U-NUT M8	4							1	(1	

REMARKS (1)YK882G (1)IT IS AN EXCLUSIVE PART FOR THE YK882G.

N077430

10. HANDLE COLUMN(MOVE-ROUND)

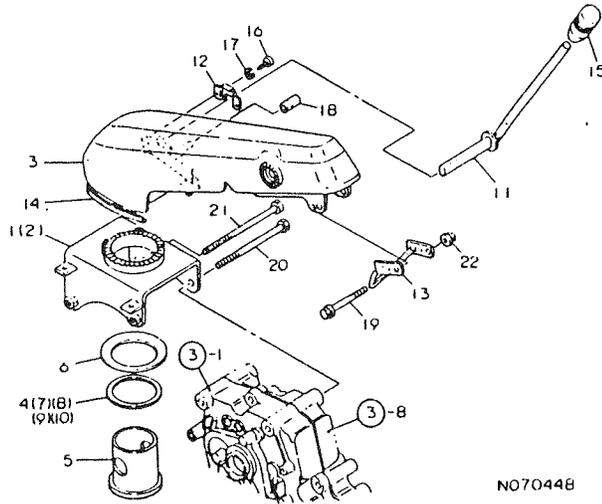

N070448

-----+
 | 1016 |
 | (1015) |
 -----+
 NPC-2436

10. HANDLE COLUMN(MOVE-ROUND)

98.03.18

(A)=YK682 (D)=
 (B)=YK882 (E)=
 (C)= (F)=

REF. NO.	LEV. D	PART NO.	DESCRIPTION	-----Q'ITY-----						I P/U A R
				(A)	(B)	(C)	(D)	(E)	(F)	
I 1	.	7A2039-51000	BRACKET PLAS.	1						0
I 2	.	7A2049-51000	BRACKET PLAS.		1					0
I 3	.	7A2049-51100	HNDL.FRAME PLAS.	1	1					0
4	.	1A2040-51190	SHIM 66X82X1	1	1					1
5	.	1A2040-51250	METAL,MOVE-RD.CORE	1	1					1
6	.	1A2040-51280	SPRING 94,BELLEVILLE	1	1					1
7	.	1A2040-51310	SHIM 66X82X0.9	1	1					1
8	.	1A2040-51320	SHIM 66X82X0.8	1	1					1
9	.	1A2040-51330	SHIM 66X82X0.7	1	1					1
10	.	1A2040-51340	SHIM 66X82X0.2	1	1					1
11	.	1A2040-51350	LEVER COMP.,MOVE-RD.	1	1					1
12	.	1A2000-51450	PLATE,MV-RD.LVR.CHK.	1	1					1
13	.	1A2040-51800	GUARD COMP.,WIRE	1	1					1
14	.	1A2040-51900	MOLDINGS,HNDL.FRAME	1	1					1
15	.	1E6570-65751	GRIP,CONTROL LEVER	1	1					1
16	.	1A1750-90050	SCREW 5X10,TAPPING	2	2					10
17	.	1A1750-90110	WASHER 5,SPRING	2	2					1
18	.	23061-070015	PIPE 7X 15	1	1					10
19	.	26107-080702	BOLT M 8X 70 PLATED	1	1					1
20	.	26116-101302	BOLT M10X130 PLATED	1	2					10
21	.	26116-101502	BOLT M10X150 PLATED	1						5
22	.	26367-080002	U-NUT M 8	1	1					10

11. HANDLE

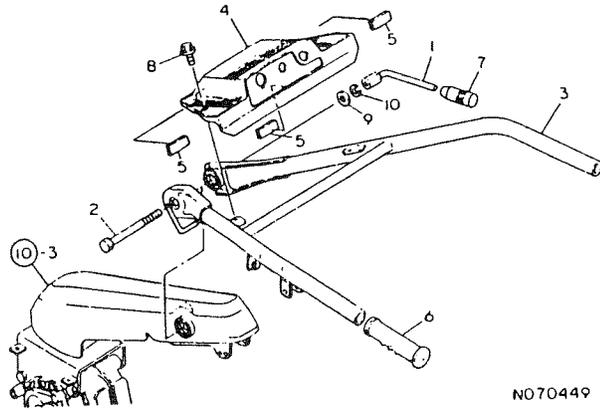

N070449

+-----+
| 1E01 |
| (1015) |
+-----+
NPC-2436

11. HANDLE

98.03.18

(A)=YK682 (D)=
(B)=YK882 (E)=
(C)= (F)=

REF. NO.	LEV. 0	PART NO.	DESCRIPTION	-----Q'TY-----						I P/U A R
				(A)	(B)	(C)	(D)	(E)	(F)	
1	.	1A2000-51400	LEVER CMP.,HANDLE LC	1	1					1
2	.	1A2000-51430	BOLT 12X125	1	1					1
3	.	1A2049-51500	HANDLE ASSY	1	1					1
4	.	1A1822-51850	COVER HANDLE	1	1					1
5	.	1A2040-51870	MOLDINGS,SOFT	3	3					1
6	.	192040-56220	GRIP,HANDLE	2	2					1
7	.	1E6570-65751	GRIP,CONTROL LEVER	1	1					1
8	.	1A2040-90100	BOLT 6X12 W/PL.WSHR.	2	2					5
9	.	22137-120000	WASHER 12,POLISHED	1	1					10
10	.	22217-120000	SPRING WASHER	1	1					10

12. TRAVELING CONTROL LEVER

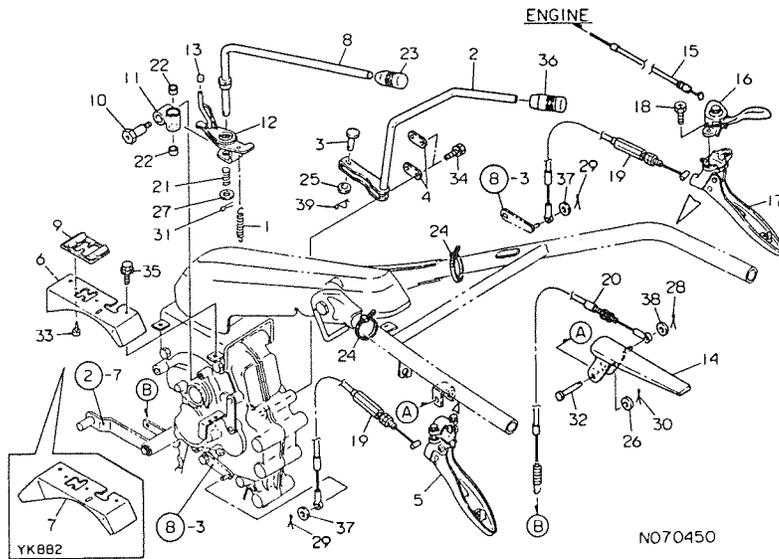

1E02
(1015)
NPC-2436

12. TRAVELING CONTROL LEVER

(A)=YK682 (D)=
(B)=YK882 (E)=
(C)= (F)=

98.03.18

REF. NO.	LEV. 0	PART NO.	DESCRIPTION	-----QTY-----						I	P/U	A	R
				(A)	(B)	(C)	(D)	(E)	(F)				
1	.	1A1470-50200	SPRING 10X76	1	1							1	
2	.	1A2049-55250	LEVER Cmpl., SUB-CHG.	1	1							1	
3	.	1A1490-50310	PIN 6X26	1	1							1	
4	.	1A1490-50340	SPRING, CHANGE LEVER	2	2							1	
5	.	7C6220-52840	SD. CLUTCH LEVER L AS	1	1							1	
6	.	1A2030-55050	COVER COMP., CHANGE	1	1							1	
6-	1	1A2031-55050 (A=F010066)	COVER COMP., CHANGE	1							R	1	
7	.	1A2040-55050	COVER COMP., CHANGE		1							1	
7-	1	1A2050-55050 (B=F030098)	COVER COMP., BELT		1						R	1	
8	.	1A2040-55101	LEVER COMP., CHANGE	1	1							1	
9	.	1A2040-55120	BASE COMP., CHG. LABEL	1	1							1	
I 9-	1	1A2040-55121 (A=F010143) (B=F030204)	BASE COMP., CHG. LABEL	1	1						R	1	
10	.	1A2040-55150	PIN, CHG. LVR. FULCRUM	1	1							1	
11	.	1A2000-55160	FULCRUM CMP. CHG. LVR.	1	1							1	
12	.	1A2040-55200	PLATE COMP., CHANGE	1	1							1	
12-	1	1A2040-55201 (A=F010066) (B=F030098)	PLATE Cmpl., CHANGE	1	1						N	1	
13	.	1A2040-55350	CAP, CHANGE SHAFT	1	1							1	
14	.	1A2009-55400	LEVER COMP., DEADMAN	1	1							1	
15	.	1A2040-54251	WIRE, ACCELERATOR	1	1							1	
16	.	1A1479-55790	ACCELERAT. LEVER	1	1							1	
17	.	7C6220-52910	SD. CLUTCH LEVER R AS	1	1							1	
18	.	1A2049-57430	BOLT M 6X 25	2	2							1	
19	.	1A1811-55700	WIRE, SIDE CLUTCH	2	2							1	
20	.	1A2049-55700	WIRE COMP., MN. CLUTCH	1	1							1	
20-	1	1A2049-55701 (A=F010036) (B=F010058)	WIRE COMP., MN. CLUTCH	1	1						N	1	
21	.	1A1104-56030	SPRING, CHANGE LEVER	1	1							2	
22	.	1A1105-57151	METAL, CHANGE LEVER	2	2							1	
23	.	1E6570-65751	GRIP, CONTROL LEVER	1	1							1	
24	.	1E6102-84970	BAND 140, WIRE LOCK	2	2							1	
25	.	22137-060000	WASHER 6, POLISHED	1	1							10	
26	.	22137-080000	WASHER 8, POLISHED	1	1							10	
27	.	22137-120000	WASHER 12, POLISHED	1	1							10	
28	.	22417-160100	COTTER PIN 1.6X10	1	1							1	
29	.	22417-200120	COTTER PIN 2.0X12	2	2							10	
30	.	22417-200150	COTTER PIN 2.0X15	1	1							10	
31	.	22417-200180	COTTER PIN 2.0X18	1	1							10	
32	.	22487-080400	PIN 8X 40	1	1							1	
33	.	22857-400080	SCREW 4X8	2	2							10	
34	.	26016-060122	BOLT M 6X 12	4	4							10	
35	.	26107-080122	BOLT M 8X 12 PLATED	2	2							5	
36	.	1E6570-65761	GRIP, CONT. LEVER RED	1	1							1	
37	.	22137-060000	WASHER 6, POLISHED	2	2							10	
38	.	22137-060000	WASHER 6, POLISHED	1	1							10	
39	.	22360-060000	SNAP PIN 6	1	1							10	

13. ENGINE FRAME & HITCH

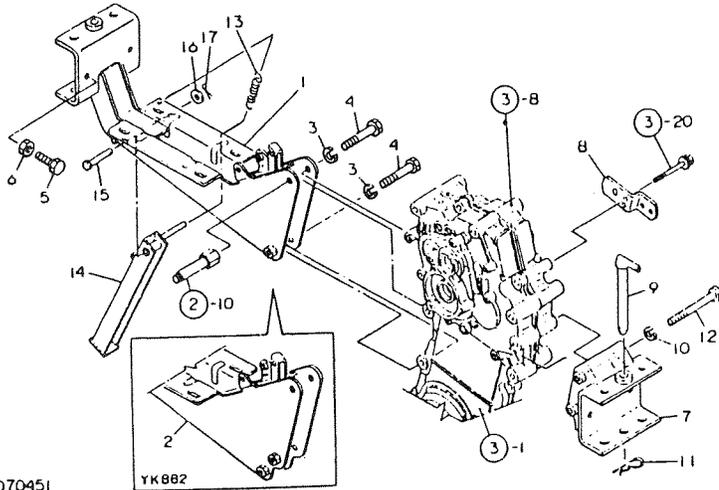

N070451

(1) REF. NOS. 7-1 & 9-1 ARE EXCLUSIVE PARTS FOR THE YK882G(GREECE).

1E04
1E03
NPC-2436

13. ENGINE FRAME & HITCH

(A)=YK682 (D)=
(B)=YK882 (E)=
(C)= (F)=

98.03.18

REF. NO.	LEV. 0	PART NO.	DESCRIPTION	Q'TY						I	P/U	A	R
				(A)	(B)	(C)	(D)	(E)	(F)				
1	.	1A2030-61000	FRAME COMP.,ENGINE	1								1	
2	.	1A2040-61000	FRAME COMP.,ENGINE		1							1	
3	.	22217-120000	SPRING WASHER	2	2							10	
4	.	26116-120602	BOLT M12X 60 PLATED	2	2							10	
5	.	26117-120252	BOLT M12X 25 PLATED	2	2							10	
6	.	26757-120002	LOCK NUT M12 PLATED	2	2							10	
I 7	.	1A2040-61401-1	HITCH COMPL.	1	1							1	
I 7-1	.	1A2049-61400 (B=F030413)	HITCH		1						N	1	(1
8	.	1A2040-61450	MOUNT COMP.,CHG.CASE	1	1							1	
9	.	1A1040-81100	PIN, HITCH	1	1							1	
I 9-1	.	1A2049-61700 (B=F030413)	PIN, HITCH		1						N	1	(1
10	.	22217-120000	SPRING WASHER	2	2							10	
11	.	22360-160000	SNAP PIN 16	1	1							10	
12	.	26116-121002	BOLT M12X100 PLATED	2	2							10	
13	.	1A1105-16001	SPRING,MN.CLTCH LVR.	1	1							1	
14	.	1A2060-61501	STAND COMPL.	1	1							1	
15	.	1A1120-62060	PIN,STAND FULCRUM	1	1							1	
16	.	22137-080000	WASHER 8, POLISHED	1	1							10	
17	.	22417-200180	COTTER PIN 2.0X18	1	1							10	

REMARKS
(1) 3つのNO. 7-1 と 9-1 は YK882G(ギリシャ) 用部品です。 (1) REF. NOS. 7-1 & 9-1 ARE EXCLUSIVE PARTS FOR THE YK882G(GREECE).

14. BELT COVER

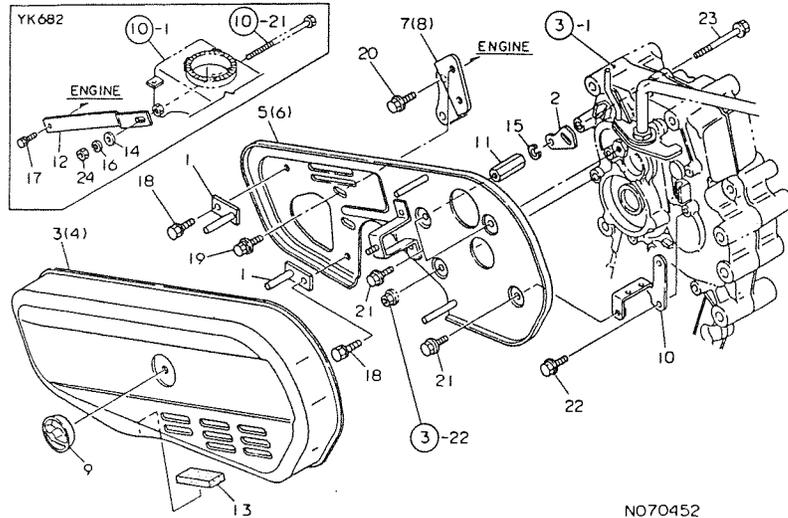

-----+
 | 1E05 |
 | (1E03) |
 +-----+
 NPC-2436

14. BELT COVER

98.03.18

(A)=YK682 (D)=
 (B)=YK882 (E)=
 (C)= (F)=

REF. NO.	LEV. 0	PART NO.	DESCRIPTION	Q'TY						I	P/U	A	R
				(A)	(B)	(C)	(D)	(E)	(F)				
1	.	1A1810-10401	RETAINER COMP.,BELT	2	2							1	
2	.	1A2040-13250	RETAINER,CLUTCH WIRE	1	1							1	
3	.	1A2030-62000	COVER,BELT	1								1	
I 3-	1	7A2039-62000 (A=F010336)	COVER,BELT PLAS.	1							N	0	
4	.	1A2040-62000	COVER,BELT		1							1	
5	.	1A2030-62101	COVER COMP.,BACK	1								1	
6	.	1A2040-62101	COVER COMP.,BACK		1							1	
7	.	1A2030-62150	STAY COMP.,ENGINE	1								1	
8	.	1A2040-62150	STAY COMP.,ENGINE		1							1	
9	.	1A2000-62300	KNOB,BELT COVER	1	1							1	
10	.	1A2040-62300	STAY,MOUNTING	1	1							1	
11	.	1A2040-62400	NUT 8X45	1	1							1	
12	.	1A2030-62500	STIFFENER	1									1
12-	1	1A2030-62501	STIFFENER	1							N	1	
		(A=F010036)											
13	.	1A2020-83330	SEAT 15X5X50	1	1							1	
14	.	22137-100000	WASHER 10,POLISHED	1	1							10	
15	.	22217-080000	SPRING WASHER 8	1	1							10	
16	.	22217-100000	SPRING WASHER 10	1								10	
17	.	26013-080164	BOLT M 8X 16	1								20	
18	.	26016-080124	BOLT M 8X 12	2	2							30	
19	.	26018-080164	BOLT M 8X 16	2	2							20	
20	.	26107-080162	BOLT M 8X 16 PLATED	2	2							5	
21	.	26107-080162	BOLT M 8X 16 PLATED	3	3							5	
22	.	26107-080162	BOLT M 8X 16 PLATED	2	2							5	
23	.	26107-080852	BOLT 8X85,COLLAR HD.	1	1							10	
24	.	26717-100002	NUT M10	1								10	

15. BONNET

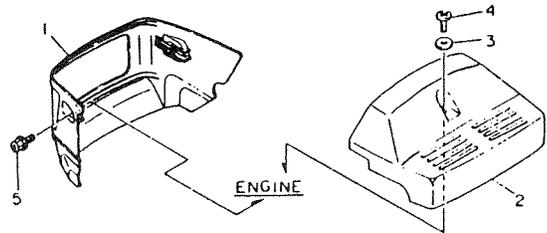

N070453

-----+
 | 1E06 |
 | (1E03) |
 +-----+
 NPC-2436

15. BONNET

98.03.18

(A)=YK682 (D)=
 (B)=YK882 (E)=
 (C)= (F)=

REF. NO.	LEV. 0	PART NO.	DESCRIPTION	-----Q'TY-----						I P/U A R
				(A)	(B)	(C)	(D)	(E)	(F)	
1	.	1A2040-64100	MASK, FRONT	1	1					1
2	.	1A2049-64200	COVER, REAR	1	1					1
3	.	1A2000-64210	WASHER 6X19X1.0	1	1					10
4	.	1A2000-64220	SCREW 6X16	1	1					1
5	.	1E4320-99120	BOLT 6X16,CRHM.	2	2					5

17. LABELS

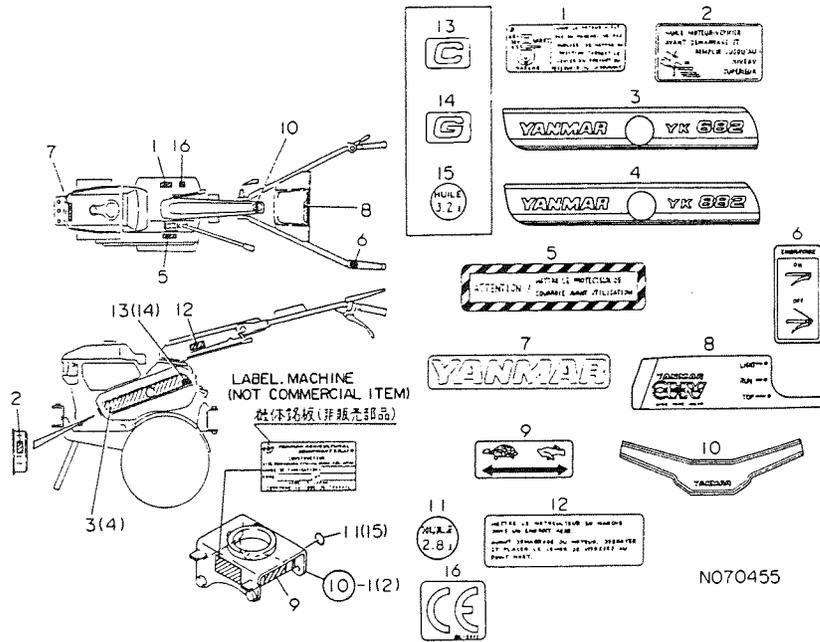

- (1) IT IS AN EXCLUSIVE PART FOR THE YK882C.
- (2) IT IS AN EXCLUSIVE PART FOR THE YK882G.
- (3) IT IS AN EXCLUSIVE PART FOR THE YK882C/YK882G.
- (4) IT IS NOT APPLICABLE TO THE YK882C/YK882G.

1E09
(1E07)
NPC-2436

17. LABELS

98.03.18

(A)=YK682
(B)=YK882
(C)=
(D)=
(E)=
(F)=

REF. NO.	LEV. 0	PART NO.	DESCRIPTION	Q'TY						I	P/U	A	R
				(A)	(B)	(C)	(D)	(E)	(F)				
1	-	160602-07800	LABEL,FUEL COCK	1	1							1	
1-1	-	1A2099-86360	LABEL,FUEL COCK	1	1							N	1
		(A=F010036) (B=F010058)											
2	-	1A1750-83350	LABEL,ENGINE OIL	1	1							1	
2-1	-	1A2099-86820	LABEL,ENG.OIL,ITA	1	1							N	1
		(A=F010036) (B=F010058)											
3	-	1A2039-86111	MARK,BELT COVER	1									1
4	-	1A2049-86111	MARK,BELT COVER		1								1
5	-	1A2099-86200	LABEL,BELT CVR.SAFTY	1	1								1
5-1	-	1A2099-86300	LABEL,CVR.SAFTY	1	1							N	1
		(A=F010036) (B=F010058)											
I 5-2	-	1A2199-86840	MARK,BELT CVR.CAUT'N	1	1								N 1
		(A=F010336) (B=F030518)											
6	-	1A2009-86210	LABEL,MAIN CLUTCH	1	1								
6-1	-	1A2009-86340	LABEL,MAIN CLUTCH	1	1								N 1
		(A=F010036) (B=F010058)											
7	-	1A2130-86320	LABEL,FUEL TANK	1	1								1
8	-	1A2049-86351	LABEL,HANDLE COVER	1	1								1
9	-	1A2049-86360	MARK,SUB-CHANGE	1	1								1
9-1	-	1A2049-86361	MARK,SUB-CHANGE	1	1								N 1
		(A=F010036) (B=F010058)											
10	-	1A2040-86470	LABEL,HANDLE	1	1								1
11	-	1A2049-86700	LABEL "1.0",OIL	1	1								1 (4)
12	-	1A1107-88130	LABEL	1	1								1
12-1	-	1A2099-86320	LABEL,CAUTION	1	1								N 1
		(A=F010036) (B=F010058)											
13	-	1A2019-86150	MARK "C"		1								1 (1)
14	-	1A2019-86170	MARK 'G'		1								1 (2)
15	-	1A2049-86710	LABEL,OIL 3.2L		1								1 (3)
I 16	-	1A6150-92250			1								W
		(B=F030423)											
I 16-1	-	1E1061-86610	MARK "CE"		1								N 1
		(B=F030463)											

REMARKS	
(1) YK882C	(1) IT IS AN EXCLUSIVE PART FOR THE YK882C.
(2) YK882G	(2) IT IS AN EXCLUSIVE PART FOR THE YK882G.
(3) YK882C,G	(3) IT IS AN EXCLUSIVE PART FOR THE YK882C/YK882G.
(4) YK882C,G	(4) IT IS NOT APPLICABLE TO THE YK882C/YK882G.

18. TOOLS

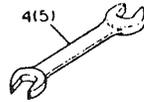
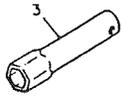
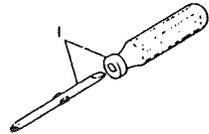
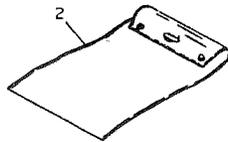

N070456

-----+
 | 1E10 |
 | (1E07) |
 +-----+
 NPC-2436

18. TOOLS

98.03.18

(A)=YK682 (D)=
 (B)=YK882 (E)=
 (C)= (F)=

REF. NO.	LEV. 0	PART NO.	DESCRIPTION	-----Q'TY-----						I P/U A R
				(A)	(B)	(C)	(D)	(E)	(F)	
1	.	1A1290-82050	SCREWDRIVER, COMBINAT	1	1					1
2	.	1A1180-83000	BAG, TOOL	1	1					1
3	.	160110-92700	BOX, SPANNER	1	1					1
4	.	28110-100120	WRENCH 10X12	1	1					1
5	.	28110-140170	WRENCH 14X17	1	1					1

19. ACCESSORIES (ADDITIONAL ITEM)

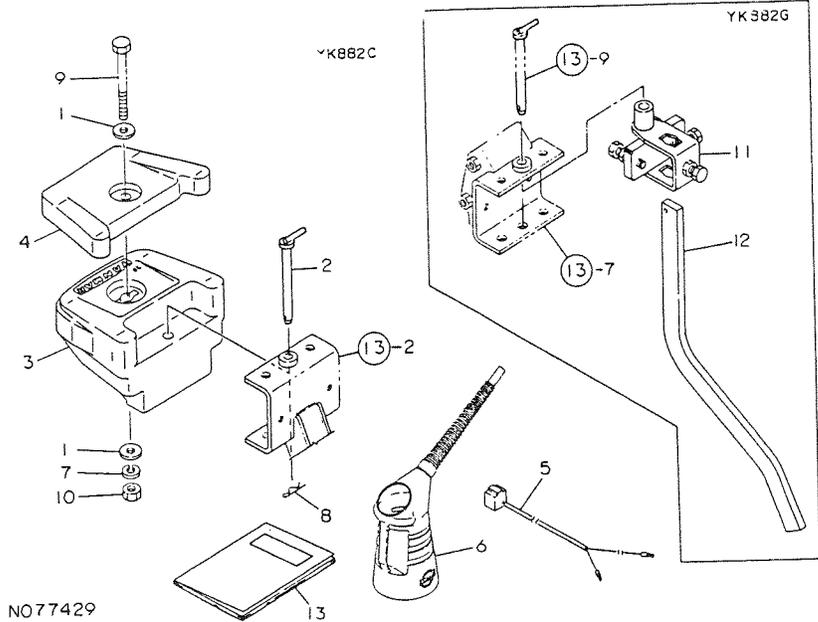

NO77429

-----+
| 1E11 |
| (1E07) |
+-----+
NPC-2436

19. ACCESSORIES (ADDITIONAL ITEM)

(A)=YK682 (D)=
(B)=YK882 (E)=
(C)= (F)=

98.03.18

REF. NO.	LEV. 0	PART NO.	DESCRIPTION	-----Q'ITY-----						I	P/U	A	R
				(A)	(B)	(C)	(D)	(E)	(F)				
I 1	.	1E6150-73410 (B=F030005)	WASHER 12X33X4.5	2						Z	1		
I 2	.	1A1040-81100 (B=F030005)	PIN, HITCH	1						Z	1		
I 3	.	1A2100-81200 (B=F030005)	WEIGHT 20, FRONT	1						Z	1		
I 4	.	1A1120-81250 (B=F030005)	WEIGHT 5, FRONT	1						Z	1		
I 5	.	1A1811-88100 (B=F030005)	HARNESS, CHARGE	1						Z	1		
I 6	.	7E4133-99290 (B=F030005)	JUG ASSY, OIL	1						Z	1		
I 7	.	22217-120000 (B=F030005)	SPRING WASHER	1						Z	10		
I 8	.	22360-160000 (B=F030005)	SNAP PIN 16	1						Z	10		
I 9	.	26117-121302 (B=F030005)	BOLT M12X130 PLATED	1						Z	10		
I 10	.	26717-120002 (B=F030005)	NUT M12	1						Z	10		
11	.	7S0070-15000	UNIVIR SAL HITCH	1							1		
12	.	1S0090-60000	BAR, RESISTANCE	1							1		
I 13	.	1A2049-88901 (B=F030523)		1						W	1		

21. LABEL (SAFETY (ADDNL.ITEM))

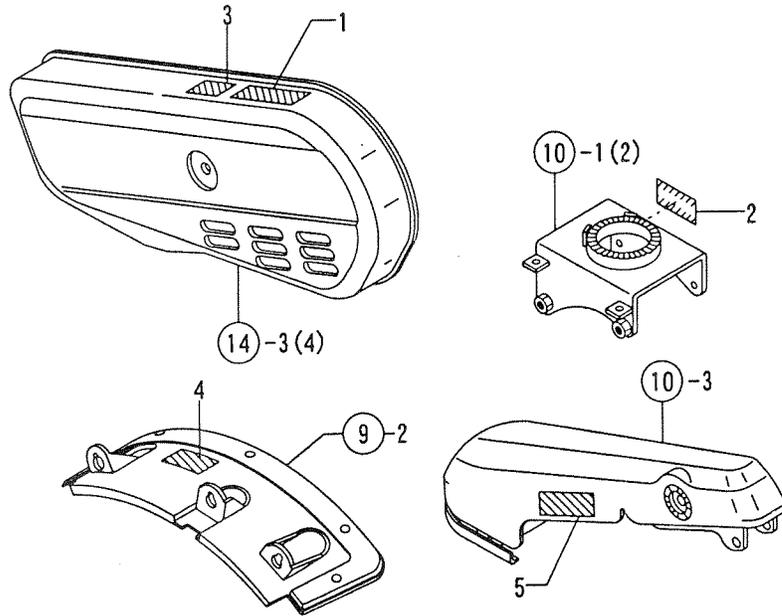
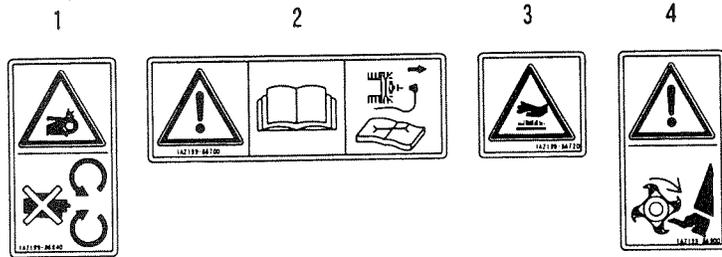

N129086

98.03.18

-----+
| 1E12 |
| (1E07) |
+-----+
NPC-2436

21. LABEL (SAFETY (ADDNL.ITEM))

(A)=YK682 (D)=
(B)=YK882 (E)=
(C)= (F)=

REF. NO.	LEV. 0	PART NO.	DESCRIPTION	-----Q'TY-----						I P/U A R
				(A)	(B)	(C)	(D)	(E)	(F)	
I 1	.	1A2199-86840	MARK,BELT CVR.CAUTION	1	1					1
I 2	.	1A2199-86700	MARK,HANDLING CAUTION	1	1					1
I 3	.	1A2199-86720	MARK,HI-TEMP.CAUTION	1	1					1
I 4	.	1A2199-86900	MARK,ROTARY CAUTION	1	1					1
I 5	.	1A2099-86320	LABEL,CAUTION	1	1					1

PART NO.	DESCRIPTION	CATALOG NO.	GRP. NO.	REF. NO.	LOC. NO.	PART NO.	DESCRIPTION	CATALOG NO.	GRP. NO.	REF. NO.	LOC. NO.
1A1040-43900	SPRING WASHER, ROD	NPC-2436	1	9	1D03	1A1510-20222	GEAR 19X15	NPC-2436	4	16-	1 1D07
1A1040-81100	PIN, HITCH	NPC-2436	13	9	1E04	1A1560-20001	CASE L,TRANSMISSION	NPC-2436	3	1	1D06
			19	2	1E11	1A1560-20002	CASE L,TRANSMISSION	NPC-2436	3	1-	1 1D06
1A1070-28160	BREATHER 10	NPC-2436	3	9	1D06	1A1560-20011	CASE R,TRANSMISSION	NPC-2436	3	8	1D06
1A1104-28230	OIL SEAL 12184	NPC-2436	7	7	1D10	1A1560-20012	CASE R,TRANSMISSION	NPC-2436	3	8-	1 1D06
				15	1D10	1A1560-24200	CHAIN 3/4X46	NPC-2436	5	12	1D08
1A1104-56030	SPRING,CHANGE LEVER	NPC-2436	12	21	1E02	1A1580-26030	SPRING 20.5 L,TORQUE	NPC-2436	8	4	1D11
1A1105-16001	SPRING,MN.CLTCH LVR.	NPC-2436	13	13	1E04	1A1580-26040	SPRING 20.5 R,TORQUE	NPC-2436	8	5	1D11
1A1105-23200	LINER 30X20.2X1	NPC-2436	5	2	1D08	1A1590-34350	PIPE,AXLE	NPC-2436	20	7	1D14
1A1105-24490	PLATE,CLTCH.OUTR.ARM	NPC-2436	8	3	1D11	1A1750-83350	LABEL,ENGINE OIL	NPC-2436	17	2	1E09
1A1105-27050	PIN,CHG.FORK SHAFT	NPC-2436	7	6	1D10	1A1750-90050	SCREW 5X10,TAPPING	NPC-2436	10	16	1D16
1A1105-57151	METAL,CHANGE LEVER	NPC-2436	12	22	1E02	1A1750-90110	WASHER 5,SPRING	NPC-2436	10	17	1D16
1A1107-88130	LABEL	NPC-2436	17	12	1E09	1A1810-10401	RETAINER COMP.,BELT	NPC-2436	14	1	1E05
1A1120-43600	LINER 20X25X1	NPC-2436	4	17	1D07	1A1811-23600	SHAFT,INTERMEDIATE	NPC-2436	5	4	1D08
1A1120-62060	PIN,STAND FULCRUM	NPC-2436	13	15	1E04	1A1811-23620	GEAR 13,BALL CLUTCH	NPC-2436	5	5	1D08
1A1120-81250	WEIGHT 5, FRONT	NPC-2436	19	4	1E11	1A1811-23630	GEAR 18	NPC-2436	5	6	1D08
1A1180-83000	BAG, TOOL	NPC-2436	18	2	1E10	1A1811-23640	DOG 18X13	NPC-2436	5	7	1D08
1A1220-28290	CAP,P.T.O.	NPC-2436	3	10	1D06	1A1811-23641	DOG 18X13	NPC-2436	5	7-	1 1D08
1A1220-64200	ROLLER, TENSION	NPC-2436	2	8	1D04	1A1811-23642	DOG 18X13	NPC-2436	5	7-	2 1D08
1A1290-36010	SNAP PIN 10	NPC-2436	20	9	1D14	1A1811-27250	FORK L CMP.,SD.CLTCH	NPC-2436	8	7	1D11
1A1290-82050	SCREWDRIVER,COMBINAT	NPC-2436	18	1	1E10	1A1811-27300	FORK R CMP.,SD.CLTCH	NPC-2436	8	8	1D11
1A1400-36050	PIN 8X55,AXLE	NPC-2436	20	10	1D14	1A1811-55700	WIRE,SIDE CLUTCH	NPC-2436	12	19	1E02
1A1470-10040	CLAMP SEAT,PULLEY	NPC-2436	2	2	1D04	1A1811-88100	HARNASS,CHARGE	NPC-2436	19	5	1E11
1A1470-20090	CAP 35,OIL FILLER	NPC-2436	3	4	1D06	1A1822-51850	COVER HANDLE	NPC-2436	11	4	1E01
1A1470-20530	OIL SEAL 305212	NPC-2436	6	1	1D09	1A2000-51400	LEVER CMP.,HANDLE LC	NPC-2436	11	1	1E01
1A1470-20560	CORE,AXLE	NPC-2436	6	2	1D09	1A2000-51430	BOLT 12X125	NPC-2436	11	2	1E01
1A1470-20570	SHIFTER	NPC-2436	6	3	1D09	1A2000-51450	PLATE,MV-RD.LVR.CHK.	NPC-2436	10	12	1D16
1A1470-20580	SPRING 41.2X26	NPC-2436	6	4	1D09	1A2000-55160	FULCRUM CMP,CHG.LVR.	NPC-2436	12	11	1E02
1A1470-20620	REAMER BOLT 8X35	NPC-2436	3	6	1D06	1A2000-62300	KNOB,BELT COVER	NPC-2436	14	9	1E05
1A1470-20832	BRACKET A,CHG.LEVER	NPC-2436	7	1	1D10	1A2000-64210	WASHER 6X19X1.0	NPC-2436	15	3	1E06
1A1470-20842	BRACKET	NPC-2436	7	2	1D10	1A2000-64220	SCREW 6X16	NPC-2436	15	4	1E06
1A1470-20940	CAP 16	NPC-2436	3	7	1D06	1A2009-55400	LEVER COMP.,DEADMAN	NPC-2436	12	14	1E02
1A1470-50200	SPRING 10X76	NPC-2436	12	1	1E02	1A2009-86210	LABEL,MAIN CLUTCH	NPC-2436	17	6	1E09
1A1479-55790	ACCELERAT.LEVER	NPC-2436	12	16	1E02	1A2009-86340	LABEL,MAIN CLUTCH	NPC-2436	17	6-	1 1E09
1A1490-20050	COVER L,PROTECTIVE	NPC-2436	3	2	1D06	1A2019-86150	MARK "C"	NPC-2436	17	13	1E09
1A1490-20070	COVER R,PROTECTIVE	NPC-2436	3	3	1D06	1A2019-86170	MARK 'G'	NPC-2436	17	14	1E09
1A1490-20180	NEEDLE K253026	NPC-2436	4	1	1D07	1A2020-83330	SEAT 15X5X50	NPC-2436	14	13	1E05
1A1490-20191	WASHER 20X36X1.6	NPC-2436	4	2	1D07	1A2030-12000	PULLEY 75,ENGINE	NPC-2436	1	6	1D03
1A1490-20201	SHAFT,COUNTER	NPC-2436	4	14	1D07	1A2030-55050	COVER COMP.,CHANGE	NPC-2436	12	6	1E02
1A1490-20210	GEAR 36	NPC-2436	4	15	1D07	1A2030-61000	FRAME COMP.,ENGINE	NPC-2436	13	1	1E04
1A1490-20310	GEAR 33	NPC-2436	5	1	1D08	1A2030-62000	COVER,BELT	NPC-2436	14	3	1E05
1A1490-20590	SPROCKET 17,AXLE	NPC-2436	6	5	1D09	1A2030-62101	COVER COMP.,BACK	NPC-2436	14	5	1E05
1A1490-20610	REAMER BOLT 8X45	NPC-2436	3	5	1D06	1A2030-62150	STAY COMP.,ENGINE	NPC-2436	14	7	1E05
1A1490-20751	SHAFT L CMP,SD.CLTCH	NPC-2436	8	1	1D11	1A2030-62500	STIFFENER	NPC-2436	14	12	1E05
1A1490-20761	SHAFT R CMP,SD.CLTCH	NPC-2436	8	2	1D11	1A2030-62501	STIFFENER	NPC-2436	14	12-	1 1E05
1A1490-20853	SHAFT A COMPL.,FORK	NPC-2436	7	3	1D10	1A2031-55050	COVER COMP.,CHANGE	NPC-2436	12	6-	1 1E02
1A1490-20883	SHAFT B COMPL.,FORK	NPC-2436	7	4	1D10	1A2039-86111	MARK,BELT COVER	NPC-2436	17	3	1E09
1A1490-20950	RETNR.PLATE A,BALL	NPC-2436	7	5	1D10	1A2040-12000	PULLEY 75 2,ENGINE	NPC-2436	1	7	1D03
1A1490-20960	RETNR.PLATE B,BALL	NPC-2436	7	13	1D10	1A2040-13000	TENSION COMPL.	NPC-2436	2	6	1D04
1A1490-50310	PIN 6X26	NPC-2436	12	3	1E02	1A2040-13010	ARM COMP.,TENSION	NPC-2436	2	7	1D04
1A1490-50340	SPRING,CHANGE LEVER	NPC-2436	12	4	1E02	1A2040-13100	NUT,TENSION	NPC-2436	2	10	1D04
1A1499-23000	SHAFT,MAIN	NPC-2436	4	3	1D07	1A2040-13250	RETAINER,CLUTCH WIRE	NPC-2436	14	2	1E05
1A1510-10000	PULLEY 185,MN.SHAFT	NPC-2436	2	1	1D04	1A2040-23010	GEAR 13	NPC-2436	4	4	1D07
1A1510-20221	GEAR 19X15	NPC-2436	4	16	1D07	1A2040-23011	GEAR 13	NPC-2436	4	4-	1 1D07

PART NO.	DESCRIPTION	CATALOG NO.	GRP. NO.	REF. NO.	LOC. NO.	PART NO.	DESCRIPTION	CATALOG NO.	GRP. NO.	REF. NO.	LOC. NO.
1A2040-23030	GEAR 24X31	NPC-2436	4	5	1D07	1A2049-27101	SHAFT C COMP.,FORK	NPC-2436	7	14-	1 1D10
1A2040-23050	WASHER 27.5,TARUST	NPC-2436	4	6	1D07	1A2049-30140	FLANGE COMP.,WHEEL	NPC-2436	20	1	1D14
1A2040-23060	LINER 20X27.5X1	NPC-2436	4	7	1D07	1A2049-30141	FLANGE COMP.,WHEEL	NPC-2436	20	1-	1 1D14
1A2040-23210	GEAR 44	NPC-2436	5	3	1D08					13	1D14
1A2040-31050	TIRE 4.00-8 W/O WHL.	NPC-2436	20	15	1D14					22	1D14
				24	1D14	1A2049-31300	TIRE L(CFRANGE	NPC-2436	20	12	1D14
1A2040-31090	VALVE TR412	NPC-2436	20	4	1D14	1A2049-31350	TIRE R(CFRANGE	NPC-2436	20	21	1D14
				17	1D14	1A2049-51500	HANDLE ASSY	NPC-2436	11	3	1E01
				26	1D14	1A2049-55250	LEVER CMPL.,SUB-CHG.	NPC-2436	12	2	1E02
1A2040-31100	WHEEL 4.00-8	NPC-2436	20	18	1D14	1A2049-55700	WIRE COMP.,MN.CLUTCH	NPC-2436	12	20	1E02
				27	1D14	1A2049-55701	WIRE COMP.,MN.CLUTCH	NPC-2436	12	20-	1 1E02
1A2040-31310	TIRE L W/WHEEL	NPC-2436	20	2	1D14	1A2049-57430	BOLT M 6X 25	NPC-2436	12	18	1E02
				14	1D14	1A2049-61400	HITCH	NPC-2436	13	7-	1 1E04
1A2040-31360	TIRE W/WHEEL R	NPC-2436	20	3	1D14	1A2049-61700	PIN, HITCH	NPC-2436	13	9-	1 1E04
				23	1D14	1A2049-64200	COVER, REAR	NPC-2436	15	2	1E06
1A2040-32100-1	FENDER L COMPL.	NPC-2436	9	1	1D13	1A2049-86111	MARK,BELT COVER	NPC-2436	17	4	1E09
1A2040-51190	SHIM 66X82X1	NPC-2436	10	4	1D16	1A2049-86351	LABEL,HANDLE COVER	NPC-2436	17	8	1E09
1A2040-51250	METAL,MOVE-RD.CORE	NPC-2436	10	5	1D16	1A2049-86360	MARK,SUB-CHANGE	NPC-2436	17	9	1E09
1A2040-51280	SPRING 94,BELLEVILLE	NPC-2436	10	6	1D16	1A2049-86361	MARK,SUB-CHANGE	NPC-2436	17	9-	1 1E09
1A2040-51310	SHIM 66X82X0.9	NPC-2436	10	7	1D16	1A2049-86700	LABEL "1.0",OIL	NPC-2436	17	11	1E09
1A2040-51320	SHIM 66X82X0.8	NPC-2436	10	8	1D16	1A2049-86710	LABEL,OIL 3.2L	NPC-2436	17	15	1E09
1A2040-51330	SHIM 66X82X0.7	NPC-2436	10	9	1D16	1A2049-88901		NPC-2436	19	13	1E11
1A2040-51340	SHIM 66X82X0.2	NPC-2436	10	10	1D16	1A2050-24500	ARM, CLUTCH	NPC-2436	8	3-	1 1D11
1A2040-51350	LEVER COMP.,MOVE-RD.	NPC-2436	10	11	1D16	1A2050-55050	COVER COMP.,BELT	NPC-2436	12	7-	1 1E02
1A2040-51800	GUARD COMP.,WIRE	NPC-2436	10	13	1D16	1A2060-61501	STAND COMPL.	NPC-2436	13	14	1E04
1A2040-51870	MOLDINGS,SOFT	NPC-2436	11	5	1E01	1A2099-86200	LABEL,BELT CVR.SAFTY	NPC-2436	17	5	1E09
1A2040-51900	MOLDINGS,HNDL.FRAME	NPC-2436	10	14	1D16	1A2099-86300	LABEL,CVR.SAFTY	NPC-2436	17	5-	1 1E09
1A2040-54251	WIRE,ACCELERATOR	NPC-2436	12	15	1E02	1A2099-86320	LABEL,CAUTION	NPC-2436	17	12-	1 1E09
1A2040-55050	COVER COMP.,CHANGE	NPC-2436	12	7	1E02				21	5	1E12
1A2040-55101	LEVER COMP.,CHANGE	NPC-2436	12	8	1E02	1A2099-86360	LABEL,FUEL COCK	NPC-2436	17	1-	1 1E09
1A2040-55120	BASE COMP.,CHG.LABEL	NPC-2436	12	9	1E02	1A2099-86820	LABEL,ENG.OIL,ITA	NPC-2436	17	2-	1 1E09
1A2040-55121	BASE COMP.,CHG.LABEL	NPC-2436	12	9-	1 1E02	1A2100-81200	WEIGHT 20,FRONT	NPC-2436	19	3	1E11
1A2040-55150	PIN,CHG.LVR.FULCRUM	NPC-2436	12	10	1E02	1A2100-83180	BULB 6V-15W/15W	NPC-2436	16	2	1E08
1A2040-55200	PLATE COMP.,CHANGE	NPC-2436	12	12	1E02	1A2130-86320	LABEL,FUEL TANK	NPC-2436	17	7	1E09
1A2040-55201	PLATE COMPL.,CHANGE	NPC-2436	12	12-	1 1E02	1A2199-86700	MARK,HANDLING CAUT'N	NPC-2436	21	2	1E12
1A2040-55350	CAP,CHANGE SHAFT	NPC-2436	12	13	1E02	1A2199-86720	MARK,HI-TEMP.CAUTION	NPC-2436	21	3	1E12
1A2040-61000	FRAME COMP.,ENGINE	NPC-2436	13	2	1E04	1A2199-86840	MARK,BELT CVR.CAUT'N	NPC-2436	17	5-	2 1E09
1A2040-61401-1	HITCH COMPL.	NPC-2436	13	7	1E04				21	1	1E12
1A2040-61450	MOUNT COMP.,CHG.CASE	NPC-2436	13	8	1E04	1A2199-86900	MARK,ROTARY CAUTION	NPC-2436	21	4	1E12
1A2040-62000	COVER,BELT	NPC-2436	14	4	1E05	1A6150-92250		NPC-2436	17	16	1E09
1A2040-62101	COVER COMP.,BACK	NPC-2436	14	6	1E05	1E1061-86610	MARK "CE"	NPC-2436	17	16-	1 1E09
1A2040-62150	STAY COMP.,ENGINE	NPC-2436	14	8	1E05	1E4030-35031	PIN 10X65,AXLE	NPC-2436	20	8	1D14
1A2040-62300	STAY,MOUNTING	NPC-2436	14	10	1E05	1E4070-79020	KEY 5X5X30	NPC-2436	2	3	1D04
1A2040-62400	NUT 8X45	NPC-2436	14	11	1E05	1E4150-16060	WASHER	NPC-2436	1	1	1D03
1A2040-64100	MASK, FRONT	NPC-2436	15	1	1E06	1E4320-99120	BOLT 6X16,CRHM.	NPC-2436	15	5	1E06
1A2040-83100	LIGHT COMPL.	NPC-2436	16	1	1E08	1E4440-26200	RETAINER,SIDE CLUTCH	NPC-2436	8	6	1D11
1A2040-83201	CORD,SWITCH	NPC-2436	16	3	1E08	1E6020-25340	SPACER 9X28X4.5	NPC-2436	1	9-	1 1D03
1A2040-83300	SWITCH,ENGINE	NPC-2436	16	4	1E08	1E6020-83890	CLIP	NPC-2436	16	5	1E08
1A2040-86470	LABEL,HANDLE	NPC-2436	17	10	1E09	1E6050-63110	COLLAR 10.5X28X3.2	NPC-2436	1	1-	1 1D03
1A2040-90100	BOLT 6X12 W/PL.WSHR.	NPC-2436	11	8	1E01	1E6102-84970	BAND 140,WIRE LOCK	NPC-2436	12	24	1E02
1A2041-12010	V BELT SA42	NPC-2436	1	12-	1 1D03	1E6150-56040	SPRING	NPC-2436	7	8	1D10
1A2049-20400	SHAFT COMPL,FINAL	NPC-2436	5	11	1D08					16	1D10
1A2049-24000	AXLE	NPC-2436	6	6	1D09	1E6150-73410	WASHER 12X33X4.5	NPC-2436	19	1	1E11
1A2049-27100	SHAFT C COMP.,FORK	NPC-2436	7	14	1D10	1E6310-36190	WASHER 8.5X35X4.5	NPC-2436	1	8	1D03

PART NO.	DESCRIPTION	CATALOG NO.	GRP. NO.	REF. NO.	LOC. NO.	PART NO.	DESCRIPTION	CATALOG NO.	GRP. NO.	REF. NO.	LOC. NO.
1E6570-65751	GRIP, CONTROL LEVER	NPC-2436	10	15	1D16	160610-01690	PLUG, DRAIN	NPC-2437	1	7	1B03
			11	7	1E01					12	1B03
			12	23	1E02			NPC-2438	1	4	1C03
1E6570-65761	GRIP, CONT. LEVER RED	NPC-2436	12	36	1E02					18	1C03
1S0090-60000	BAR, RESISTANCE	NPC-2436	19	12	1E11	160610-03050	BREATHER ASSY	NPC-2438	2	1	1C04
104200-59170	GASKET 12	NPC-2437	1	8	1B03	160610-04201	BOLT M 8X 53	NPC-2437	1	21	1B03
		NPC-2438		13	1B03	160610-04910	NUT M14	NPC-2437	5	13	1B07
			1	5	1C03	160610-55100	STRAINER	NPC-2437	6	12	1B08
				19	1C03			NPC-2438	7	12	1C10
106990-44660	BAND, HOSE	NPC-2437	6	28	1B08	160610-55470	PIECE	NPC-2437	6	22	1B08
		NPC-2438	7	30	1C10			NPC-2438	7	22	1C10
114250-14400	ROD, PUSH	NPC-2437	5	12	1B07	160610-56150	GASKET, CARBURETOR	NPC-2437	4	10	1B06
		NPC-2438	5	12	1C07				7	36	1B09
114250-45310	COLLAR	NPC-2437	6	1	1B08	160610-56610	GASKET	NPC-2437	7	20	1B09
		NPC-2438	7	1	1C10	160610-56630	PIN, FLOAT	NPC-2437	7	13	1B09
114252-13800	PIPE ASSY, EXTERNAL	NPC-2438	4	17	1C06			NPC-2438	8	21	1C11
114252-13910	CLAMP	NPC-2438	4	18	1C06	160640-56850	SEAL	NPC-2437	7	27	1B09
114252-13950	BOLT M 6X 8 PLATED	NPC-2437	4	13C	1B06			NPC-2438	8	26	1C11
		NPC-2438		19	1B06	160641-76570	SCREW, CENTER	NPC-2438	6	14	1C08
		NPC-2438	4	14	1C06	160664-66220	SPRING, RETURN	NPC-2437	8	24	1B10
114252-13960	SCREW 6X 25	NPC-2438	4	19	1C06			NPC-2438	9	27	1C12
114270-01600	PARALLEL PIN 8X12	NPC-2438	1	6-1	1C03	160667-56750	SCREW, ADJUSTING	NPC-2437	7	30	1B09
114370-45350	BOLT, FAN CASE	NPC-2438	7	29-1	1C10			NPC-2438	8	8	1C11
114770-61600	SEAL, OIL	NPC-2437	8	34	1B10	160670-66350	COLLAR	NPC-2437	8	25	1B10
		NPC-2438	9	38	1C12			NPC-2438	9	28	1C12
124060-77680	CLAMP 10	NPC-2437	6	32	1B08	160690-02220	OIL SEAL TC25416	NPC-2437	1	5	1B03
		NPC-2438	7	34	1C10					15	1B03
135210-61090	LEAD	NPC-2438	9	19	1C12	160690-03050	BREATHER	NPC-2437	2	20	1B04
160110-01870	PLUG, RUBBER W/SCREW	NPC-2437	1	23	1B03	160690-11010	HEAD ASSY, CYLINDER	NPC-2437	2	2	1B04
		NPC-2438	1	25	1C03	160690-11100	VALVE, INTAKE	NPC-2437	2	6	1B04
160110-02220	SEAL, OIL	NPC-2438	1	7	1C03	160690-11110	VALVE, EXHAUST	NPC-2437	2	7	1B04
				15	1C03	160690-11120	SPRING, VALVE	NPC-2437	2	8	1B04
160110-92700	BOX, SPANNER	NPC-2436	18	3	1E10	160690-11180	RETAINER, SPRING	NPC-2437	2	9	1B04
160120-56670	SCREW	NPC-2438	8	3	1C11	160690-11200	ARM, ROCKER	NPC-2437	2	10	1B04
160120-76940	WASHER	NPC-2437	8	9	1B10	160690-11220	PIVOT, ROCKER ARM	NPC-2437	2	11	1B04
		NPC-2438	9	10	1C12			NPC-2438	2	14	1C04
160210-56610	WASHER	NPC-2438	8	13	1C11	160690-11221	PIVOT, ROCKER ARM	NPC-2438	2	14-1	1C04
160260-76620	KNOB, STARTER	NPC-2438	6	17	1C08	160690-11270	BOLT	NPC-2437	2	12	1B04
160310-56980	SPRING, CHOKE	NPC-2437	7	15	1B09			NPC-2438	2	15	1C04
160310-56990	BALL, STEEL	NPC-2437	7	16	1B09	160690-11271	BOLT	NPC-2437	2	12-1	1B04
160341-01950	PIPE	NPC-2437	9	40	1B12			NPC-2438	2	15-1	1C04
		NPC-2438	6	21	1C08	160690-11280	NUT M6X 0.5	NPC-2437	2	13	1B04
				21-1	1C08			NPC-2438	2	16	1C04
160393-55050	GASKET, TANK CAP	NPC-2437	6	11	1B08	160690-11290	PLATE, GUIDE	NPC-2437	2	14	1B04
		NPC-2438	7	11	1C10	160690-11300	BONNET	NPC-2437	2	16	1B04
160460-56940	JET, PILOT	NPC-2438	8	9	1C11	160690-11310	GASKET, BONNET	NPC-2437	2	17	1B04
160490-14200	TAPPET	NPC-2437	5	11	1B07	160690-12261	SPACER, AIR CLEANER	NPC-2437	4	1	1B06
160520-66291	SPRING	NPC-2437	8	22	1B10	160690-13200	GASKET, MUFFLER	NPC-2437	4	12	1B06
		NPC-2438	9	23	1C12	160690-14560	SPRING, DECOMP.	NPC-2437	5	8	1B07
160590-21210	GEAR, IDLE	NPC-2437	5	17	1B07	160690-14570	SPRING, DECOMP.	NPC-2437	5	8-1	1B07
160592-56670	BODY, FLOAT CHAMBER	NPC-2437	7	21	1B09	160690-21201	GEAR, CRANKSHAFT	NPC-2437	5	16	1B07
160602-07370	LABEL, AIR CLEANER	NPC-2437	3	5	1B05	160690-22300	PIN, PISTON	NPC-2437	5	26	1B07
		NPC-2438	3	5	1C05	160690-45011	FAN	NPC-2437	9	11	1B11
160602-07800	LABEL, FUEL COCK	NPC-2436	17	1	1E09	160690-45200	COVER, CYLINDER	NPC-2437	9	13	1B11

PART NO.	DESCRIPTION	CATALOG NO.	GRP. NO.	REF. NO.	LOC. NO.	PART NO.	DESCRIPTION	CATALOG NO.	GRP. NO.	REF. NO.	LOC. NO.
160690-45210	COVER, REAR	NPC-2437	9	14	1B11	160690-78230	CORD, STOP	NPC-2437	9	6A	1B11
160690-45211	COVER, REAR	NPC-2437	9	14- 1	1B11			NPC-2438	6	27A	1C08
				14- 2	1B11	160690-78531	COIL, IGNITION	NPC-2437	9	6	1B11
160690-55140	BOLT, FAN CASE	NPC-2438	7	29- 2	1C10	160690-78532	IGNITER	NPC-2437	9	6- 1	1B11
160690-55460	DAMPER, FUEL TANK	NPC-2437	6	21	1B08	160692-04310	BOLT M6X143	NPC-2437	2	1	1B04
		NPC-2438	7	21	1C10	160692-07370	LABEL, AIR CLEANER	NPC-2437	3	6	1B05
160690-55461	DAMPER, FUEL TANK	NPC-2438	7	21- 1	1C10			NPC-2438	3	7	1C05
160690-56160	SPACER	NPC-2437	7	37	1B09	160692-12500	CLEANER ASSY, AIR	NPC-2437	4	2	1B06
160690-59400	PROTECTOR, PIPE	NPC-2437	6	31	1B08	160692-12510	BODY ASSY	NPC-2437	4	3	1B06
160690-61300	SPINDLE, GOVERNOR	NPC-2437	8	2- 1	1B10	160692-12520	ELEMENT ASSY, AIR CL.	NPC-2437	4	4	1B06
		NPC-2438	9	2- 1	1C12	160692-12530	SUMP, OIL	NPC-2437	4	5	1B06
160690-61301	SPINDLE, GOVERNOR	NPC-2437	8	2	1B10	160692-12540	RING	NPC-2437	4	6	1B06
		NPC-2438	9	2	1C12	160692-12920	NET	NPC-2437	4	8	1B06
				2- 2	1C12	160692-13511	MUFFLER	NPC-2437	4	13A	1B06
160690-61310	SHAFT, GOV. LEVER	NPC-2437	8	3	1B10	160692-13520	MUFFLER ASSY	NPC-2437	4	13	1B06
		NPC-2438	9	3	1C12	160692-13530	COVER, MUFFLER	NPC-2437	4	14	1B06
160690-61311	SHAFT, GOV. LEVER	NPC-2438	9	3- 1	1C12	160692-13600	COVER, ELBOW	NPC-2437	4	13B	1B06
160690-61450	WASHER	NPC-2437	8	4	1B10	160692-13750	DUCT, EXHAUST	NPC-2437	4	15	1B06
		NPC-2438	9	4	1C12	160692-13820	GASKET, TAIL PIPE	NPC-2437	4	17	1B06
160690-61600	GEAR ASSY, GOV.	NPC-2437	8	5	1B10	160692-13850	SCREW M 5X 8	NPC-2437	4	18	1B06
		NPC-2438	9	5	1C12	160692-14051	CAMSHAFT ASSY	NPC-2437	5	1	1B07
160690-66010	SPRING, GOVERNOR	NPC-2437	8	11	1B10	160692-45110	CASE, FAN (RED)(50)	NPC-2437	9	12	1B11
160690-66011	SPRING, GOVERNOR	NPC-2437	8	11- 1	1B10	160692-55300	COCK ASSY, FUEL	NPC-2437	6	14	1B08
160690-66111	BASE ASSY, CONTROL	NPC-2437	8	18	1B10			NPC-2438	7	14	1C10
160690-66140	BASE ASSY, CONTROL	NPC-2437	8	19	1B10	160692-55421	PLATE	NPC-2437	6	20	1B08
160690-66141	BASE, CONTROL	NPC-2437	8	19- 1	1B10			NPC-2438	7	20	1C10
160690-66142	BASE, CONTROL	NPC-2437	8	19- 2	1B10	160692-56560	VALVE, NEEDLE(RUBBER	NPC-2437	7	39	1B09
160690-66143	BASE, CONTROL	NPC-2437	8	19- 3	1B10	160692-56620	O-RING	NPC-2437	7	28	1B09
160690-66180	LEVER ASSY, GOVERNOR	NPC-2437	8	28	1B10			NPC-2438	8	29	1C11
160690-66200	LINK, THROTTLE	NPC-2437	8	31	1B10	160692-56700	SEAL, RUBBER	NPC-2437	7	33	1B09
		NPC-2438	9	35	1C12	160692-56710	SCREW	NPC-2437	7	8	1B09
160690-66210	SPRING, TENSION	NPC-2437	8	32	1B10	160692-56730	BOLT	NPC-2437	7	23	1B09
		NPC-2438	9	36	1C12	160692-56760	BODY, COCK	NPC-2437	7	29	1B09
160690-76050	STARTER ASSY, RECOIL	NPC-2437	9	18	1B11	160692-56770	HOSE	NPC-2437	7	34	1B09
160690-76250	STARTER ASSY, RECOIL	NPC-2437	9	19	1B11			NPC-2438	8	31	1C11
160690-76510	CASE, STARTER	NPC-2437	9	20	1B11	160692-56800	SEAL, RUBBER	NPC-2437	7	32	1B09
160690-76520	REEL	NPC-2437	9	21	1B11	160692-56900	ROD, CHOKE	NPC-2437	7	40	1B09
160690-76530	GUIDE, RATCHET	NPC-2437	9	25	1B11			NPC-2438	8	37	1C11
160690-76540	SPRING, SPIRAL	NPC-2437	9	26	1B11	160692-59350	PIPE, FUEL OIL	NPC-2437	6	29	1B08
160690-76550	WASHER, THRUST	NPC-2437	9	28	1B11	160692-66051	LEVER ASSY, CONTROL	NPC-2437	8	13	1B10
160690-76560	SPRING, FRICTION	NPC-2437	9	27	1B11			NPC-2438	9	13	1C12
160690-76580	PLATE, FRICTION	NPC-2437	9	24	1B11	160692-66101	CONTROL ASSY	NPC-2437	8	12	1B10
160690-76590	PULLEY, STARTER	NPC-2437	9	36	1B12	160693-76050	STARTER ASSY, RECOIL	NPC-2437	9	18- 1	1B11
160690-76620	KNOB, STARTER	NPC-2437	9	33	1B12	160693-76250	STARTER ASSY, RECOIL	NPC-2437	9	19- 1	1B11
160690-76630	ROPE, STARTER	NPC-2437	9	32	1B11	160693-76510	CASE, STARTER	NPC-2437	9	20- 1	1B11
160690-76800	RATCHET	NPC-2437	9	22	1B11	160693-78071	MAGNET ASSY, FLYWHEEL	NPC-2437	9	4	1B11
160690-76810	PIN, RATCHET	NPC-2437	9	23	1B11	160693-78510	ROTOR	NPC-2437	9	5	1B11
160690-76820	SHAFT	NPC-2437	9	29	1B11	160693-78620	COIL, LAMP	NPC-2437	9	6B	1B11
160690-76830	CAP, KNOB	NPC-2437	9	34	1B12			NPC-2438	6	28	1C08
160690-76840	PLATE, SLIDE	NPC-2437	9	35	1B12	160698-01330	GASKET, CYL. HEAD	NPC-2437	1	9	1B03
160690-78010	PLUG, SPARK	NPC-2437	9	1	1B11	160698-07350	LABEL	NPC-2437	3	7	1B05
		NPC-2438	6	22	1C08			NPC-2438	3	6	1C05
160690-78020	PLUG, SPARK	NPC-2437	9	1- 1	1B11	160698-22010	PISTON W/RINGS	NPC-2437	5	20	1B07
		NPC-2438	6	22- 1	1C08	160698-56020	CARBURETOR	NPC-2437	7	1	1B09

PART NO.	DESCRIPTION	CATALOG NO.	GRP. NO.	REF. NO.	LOC. NO.	PART NO.	DESCRIPTION	CATALOG NO.	GRP. NO.	REF. NO.	LOC. NO.
160698-56520	VALVE, THROTTLE	NPC-2437	7	3	1B09	160790-45210	COVER, REAR	NPC-2438	6	3	1C08
160698-56530	VALVE, THROTTLE	NPC-2437	7	6	1B09	160790-56150	GASKET, CARBURETOR	NPC-2438	8	33	1C11
160698-56540	JET, PILOT	NPC-2437	7	7	1B09	160790-56160	INSULATOR, CARBURETOR	NPC-2438	8	35	1C11
160698-56550	SHAFT, THROTTLE	NPC-2437	7	14	1B09	160790-66010	SPRING, GOVERNOR	NPC-2438	9	11	1C12
160698-56560	LEVER, CHOKE	NPC-2437	7	17	1B09	160790-76050	STARTER ASSY, RECOIL	NPC-2438	6	7	1C08
160698-56570	NOZZLE, MAIN	NPC-2437	7	22	1B09	160790-76590	PULLEY, STARTER	NPC-2438	6	18	1C08
160698-56580	JET, MAIN	NPC-2437	7	25	1B09	160790-78500	ROTOR	NPC-2438	6	26	1C08
160699-45010	FAN, COOLING	NPC-2437	9	11- 1	1B11	160790-78511	COIL, IGNITION	NPC-2438	6	27	1C08
160699-45200	COVER, CYLINDER	NPC-2437	9	13- 1	1B11	160790-78512	IGNITER	NPC-2438	6	27- 1	1C08
160700-78040	CAP, PLUG	NPC-2437	9	2	1B11	160792-04310	BOLT M 6X159	NPC-2438	2	3	1C04
		NPC-2438	6	23	1C08	160792-12500	CLEANER ASSY, AIR	NPC-2438	4	1	1C06
160700-78050	TERMINAL, PLUG	NPC-2437	9	3	1B11	160792-12510	BODY, AIR CLEANER	NPC-2438	4	2	1C06
		NPC-2438	6	24	1C08	160792-12720	ELEMENT	NPC-2438	4	3	1C06
160700-78720	GROMMET	NPC-2437	9	9	1B11	160792-12780	PIPE	NPC-2438	4	5	1C06
		NPC-2438	6	30	1C08	160792-12900	CAP, INTAKE	NPC-2438	4	7	1C06
160702-56720	RING	NPC-2437	7	31	1B09	160792-12920	NET	NPC-2438	4	9	1C06
		NPC-2438	8	25	1C11	160792-13500	MUFFLER	NPC-2438	4	12	1C06
160708-07260	MARK, CAUTION	NPC-2437	3	4	1B05	160792-13530	COVER, MUFFLER	NPC-2438	4	13	1C06
		NPC-2438	3	4	1C05	160792-13560	MUFFLER	NPC-2438	4	12- 1	1C06
160710-01760	CAP, W/LUB.OIL GAUGE	NPC-2437	1	18	1B03	160792-45110	CASE, FAN (RED) (50)	NPC-2438	6	1	1C08
160710-03190	PIPE, BREATHER	NPC-2438	2	2	1C04	160792-55150	GUAGE, FUEL	NPC-2437	6	13	1B08
160710-23201	BOLT, ROD	NPC-2437	5	30	1B07			NPC-2438	7	13	1C10
160710-55061	CAP ASSY, FUEL TANK	NPC-2437	6	4	1B08	160792-55160	GAUGE, FUEL	NPC-2437	6	13- 1	1B08
		NPC-2438	7	4	1C10			NPC-2438	7	13- 1	1C10
160710-55360	RING	NPC-2437	6	16	1B08	160792-55900	GUIDE, F.TANK (RED:50)	NPC-2437	6	23	1B08
		NPC-2438	7	16	1C10			NPC-2438	7	23	1C10
160710-55370	GASKET	NPC-2437	6	17	1B08	160792-55920	COVER, SIDE (RED)(50)	NPC-2437	6	24	1B08
		NPC-2438	7	17	1C10			NPC-2438	7	24	1C10
160710-55381	STRAINER, FUEL	NPC-2437	6	18	1B08	160792-55950	SCREW 5X8, CRPHM.	NPC-2437	6	25	1B08
		NPC-2438	7	18	1C10			NPC-2438	7	25	1C10
160710-55382	FILTER	NPC-2437	6	18- 1	1B08	160792-56010	CARBURETOR ASSY	NPC-2438	8	1	1C11
		NPC-2438	7	18- 1	1C10	160792-56430	BODY, FLOAT	NPC-2438	8	23	1C11
160710-55390	BOWL, STRAINER	NPC-2437	6	19	1B08	160792-56520	VALVE, CHOKE	NPC-2438	8	6	1C11
		NPC-2438	7	19	1C10	160792-56530	SHAFT, THROTTLE	NPC-2438	8	10	1C11
160710-78710	CLAMP, CORD	NPC-2437	6	33	1B08	160792-56540	RING	NPC-2438	8	11	1C11
			9	39	1B12	160792-56550	SPRING	NPC-2438	8	12	1C11
		NPC-2438	6	29	1C08	160792-56560	NOZZLE, MAIN	NPC-2438	8	15	1C11
				29- 1	1C08	160792-56570	JET, ENRICHMENT	NPC-2438	8	16	1C11
			7	26	1C10	160792-56580	GASKET	NPC-2438	8	17	1C11
160730-56880	HOSE D5/3	NPC-2438	8	36	1C11	160792-56590	BOLT	NPC-2438	8	18	1C11
160762-12870	CAP, INTAKE	NPC-2437	4	7	1B06	160792-56600	GASKET	NPC-2438	8	24	1C11
160763-12600	GROMMET, AIR CLEANER	NPC-2437	4	9	1B06	160792-56610	BOLT	NPC-2438	8	27	1C11
		NPC-2438	4	6	1C06	160792-56620	JET, MAIN AIR	NPC-2438	8	28	1C11
160769-56620	FLOAT ASSY	NPC-2437	7	12	1B09	160792-56630	BODY, CHAMBER	NPC-2438	8	30	1C11
160790-01330	GASKET, CYL. HEAD	NPC-2438	1	11	1C03	160792-56640	SCREW	NPC-2438	8	32	1C11
160790-11010	HEAD ASSY, CYLINDER	NPC-2438	2	4	1C04	160792-56670	VALVE, NEEDLE (RUBBER)	NPC-2438	8	38	1C11
160790-11011	HEAD ASSY, CYLINDER	NPC-2438	2	4- 1	1C04	160792-59350	FUEL PIPE (A)	NPC-2438	7	31	1C10
160790-11100	VALVE, INTAKE	NPC-2438	2	9	1C04	160792-59360	PIPE, FUEL	NPC-2438	7	32	1C10
160790-11110	VALVE, EXHAUST	NPC-2438	2	10	1C04	160792-59400	PIPE, PROTECTIVE	NPC-2438	7	33	1C10
160790-14560	SPRING, DECOMP.	NPC-2438	5	8	1C07	160792-66110	CONTROL ASSY	NPC-2438	9	12	1C12
160790-22010	PISTON ASSY	NPC-2438	5	21	1C07	160792-66120	BASE ASSY, CONTROL	NPC-2438	9	18	1C12
160790-22011	PISTON W/RINGS	NPC-2438	5	21- 1	1C07	160792-78061	MAGNET ASSY, FLYWHEEL	NPC-2438	6	25	1C08
160790-28010	SHAFT, BALANCER	NPC-2438	5	33	1C07	160798-07100	LABEL, FINGER START	NPC-2437	3	2	1B05
160790-45110	CASE, FAN (RED) (50)	NPC-2438	6	1- 1	1C08			NPC-2438	3	2	1C05

PART NO.	DESCRIPTION	CATALOG NO.	GRP. NO.	REF. NO.	LOC. NO.	PART NO.	DESCRIPTION	CATALOG NO.	GRP. NO.	REF. NO.	LOC. NO.	
160802-56480	GASKET	NPC-2437	7	24	1B09	192040-56220	GRIP, HANDLE	NPC-2436	11	6	1E01	
160810-01740	CAP, W/LUB.OIL GAUGE	NPC-2438	1	21	1C03	22117-120000	WASHER 12	NPC-2436	2	11	1D04	
160810-11180	RETAINER, SPRING	NPC-2438	2	12	1C04	22137-060000	WASHER 6, POLISHED	NPC-2436	12	25	1E02	
160810-23201	BOLT, ROD	NPC-2438	5	31	1C07					37	1E02	
160810-56150	GASKET, CARBURETOR	NPC-2438	8	34	1C11					38	1E02	
160810-56580	RING, CHOKE SHAFT	NPC-2437	7	18	1B09	22137-080000	WASHER 8, POLISHED	NPC-2436	1	2	1D03	
		NPC-2438	8	19	1C11					12	26	1E02
160810-56590	RING, CHOKE LEVER	NPC-2437	7	19	1B09					13	16	1E04
160810-56620	FLOAT ASSY	NPC-2438	8	14	1C11	22137-100000	WASHER 10, POLISHED	NPC-2436	1	2-	1D03	
160810-56670	SCREW	NPC-2437	7	4	1B09					14	14	1E05
160820-03180	PIPE, BREATHER	NPC-2437	2	21	1B04	22137-120000	WASHER 12, POLISHED	NPC-2436	11	9	1E01	
160820-12770	SUMP, OIL	NPC-2438	4	4	1C06					12	27	1E02
160820-59390	PIPE, FUEL	NPC-2437	6	30	1B08	22137-160000	WASHER 16, POLISHED	NPC-2438	5	19-	1C07	
160820-78710	CLAMP, CORD	NPC-2438	7	35	1C10	22217-060000	SPRING WASHER 6	NPC-2436	7	9	1D10	
160880-56761	VALVE, THROTTLE	NPC-2438	8	4	1C11	22217-080000	SPRING WASHER 8	NPC-2436	1	3	1D03	
160890-01210	BOLT 10X 70	NPC-2438	1	10	1C03					3	11	1D06
160890-11120	SPRING, VALVE	NPC-2438	2	11	1C04						12	1D06
160890-11180	RETAINER, SPRING	NPC-2438	2	12-	1C04					14	15	1E05
160890-11200	ARM, ROCKER	NPC-2438	2	13	1C04	22217-100000	SPRING WASHER 10	NPC-2436	1	3-	1D03	
160890-11202	ARM, ROCKER	NPC-2438	2	13-	1C04					14	16	1E05
160890-11270	BOLT, ROCKER ARM	NPC-2438	2	15-	2C04	22217-120000	SPRING WASHER	NPC-2436	11	10	1E01	
160890-11290	PLATE, GUIDE	NPC-2438	2	17	1C04					13	3	1E04
160890-11300	BONNET	NPC-2438	2	19	1C04						10	1E04
160890-11310	GASKET, BONNET	NPC-2438	2	20	1C04					19	7	1E11
160890-13210	GASKET, MUFFLER	NPC-2438	4	11	1C06	22217-160000	SPRING WASHER 16	NPC-2438	5	19	1C07	
160890-14051	CAMSHAFT ASSY	NPC-2438	5	1	1C07	22242-000120	CIRCLIP 12	NPC-2436	2	12	1D04	
160890-14200	TAPPET	NPC-2438	5	11	1C07	22242-000150	CIRCLIP 15	NPC-2436	2	9	1D04	
160890-14560	SPRING, DECOMP.	NPC-2438	5	8-	1C07	22242-000200	CIRCLIP 20	NPC-2436	4	8	1D07	
160890-21200	GEAR, CRANKSHAFT	NPC-2438	5	15	1C07	22252-000160	CIRCLIP 16	NPC-2437	5	27	1B07	
160890-21220	GEAR, BALANCER	NPC-2438	5	16	1C07	22252-000190	CIRCLIP 19	NPC-2438	5	28	1C07	
				32	1C07	22312-080120	PARALLEL PIN 8X12	NPC-2437	1	4	1B03	
160890-22300	PIN, PISTON	NPC-2438	5	27	1C07					1	6	1C03
160890-45200	HEAD COVER, SIDE	NPC-2438	6	2	1C08	22351-040008	SPRING PIN 4X 8	NPC-2438	5	35	1C07	
160890-66050	SPRING, RETURN	NPC-2438	9	9	1C12	22360-060000	SNAP PIN 6	NPC-2436	12	39	1E02	
160890-66140	BASE, CONTROL	NPC-2438	9	20	1C12	22360-080000	SNAP PIN 8	NPC-2436	20	11	1D14	
160890-66141	BASE, CONTROL	NPC-2438	9	20-	1C12	22360-160000	SNAP PIN 16	NPC-2436	13	11	1E04	
160890-66142	BASE, CONTROL	NPC-2438	9	20-	2C12					19	8	1E11
160890-66190	LEVER ASSY, GOVERNOR	NPC-2438	9	31	1C12	22372-080000	SNAP PIN (JASO 8)	NPC-2437	8	10	1B10	
160890-76250	RECOIL ASSY	NPC-2438	6	8	1C08	22417-160100	COTTER PIN 1.6X10	NPC-2436	12	28	1E02	
160890-76510	SPRING, SPIRAL	NPC-2438	6	9	1C08	22417-200120	COTTER PIN 2.0X12	NPC-2436	8	9	1D11	
160890-76520	REEL	NPC-2438	6	10	1C08					12	29	1E02
160890-76530	SPRING	NPC-2438	6	11	1C08	22417-200150	COTTER PIN 2.0X15	NPC-2436	12	30	1E02	
160890-76540	DOG	NPC-2438	6	12	1C08	22417-200180	COTTER PIN 2.0X18	NPC-2436	12	31	1E02	
160890-76550	SPRING, BRAKE	NPC-2438	6	13	1C08					13	17	1E04
160890-76570	RETAINER	NPC-2438	6	15	1C08	22451-060000	WIRE 0.6	NPC-2438	9	25	1C12	
160890-76580	ROPE	NPC-2438	6	16	1C08	22487-080400	PIN 8X 40	NPC-2436	12	32	1E02	
160903-28020	BALL BEARING	NPC-2438	1	9	1C03	22512-040120	KEY 4X 12	NPC-2437	5	10	1B07	
				17	1C03						18	1B07
			5	34	1C07	22512-040160	KEY 4X 16	NPC-2437	5	19	1B07	
160903-56670	SCREW	NPC-2437	7	5	1B09					5	17	1C07
		NPC-2438	8	5	1C11	22512-040300	KEY 4X 30	NPC-2438	5	18	1C07	
160910-66440	BOLT	NPC-2438	9	24	1C12	22512-050160	KEY 5X16, FEATHER	NPC-2438	5	10	1C07	
181230-56380	SPRING	NPC-2437	7	9	1B09	22512-050300	KEY 5X 30	NPC-2436	1	10	1D03	
		NPC-2438	8	7	1C11					2	3-	1D04

PART NO.	DESCRIPTION	CATALOG NO.	GRP. NO.	REF. NO.	LOC. NO.	PART NO.	DESCRIPTION	CATALOG NO.	GRP. NO.	REF. NO.	LOC. NO.
22512-070380	KEY 7X 38	NPC-2436	1	11	1D03	26107-060122	BOLT M 6X 12 PLATED	NPC-2436	16	6	1E08
22550-050201	KEY 5X20	NPC-2436	4	19	1D07	26107-080122	BOLT M 8X 12 PLATED	NPC-2436	3	16	1D06
22857-400080	SCREW 4X8	NPC-2436	12	33	1E02				9	3	1D13
23061-030180	HOSE D5/3	NPC-2437	7	38	1B09				12	35	1E02
23061-070015	PIPE 7X 15	NPC-2436	10	18	1D16				16	7	1E08
23414-060000	GASKET 6, ROUND	NPC-2436	3	13	1D06	26107-080162	BOLT M 8X 16 PLATED	NPC-2436	3	17	1D06
23414-080000	GASKET 8, ROUND	NPC-2436	3	14	1D06				14	20	1E05
24101-062034	BALL BEARING	NPC-2436	4	18	1D07					21	1E05
24101-062044	BALL BEARING	NPC-2436	4	9	1D07					22	1E05
24101-062050	BALL BEARING	NPC-2437	1	6	1B03	26107-080182	BOLT M 8X 18 PLATED	NPC-2436	20	5	1D14
				14	1B03					19	1D14
				16	1B03					28	1D14
24101-062060	BALL BEARING	NPC-2438	1	8	1C03	26107-080302	BOLT M 8X 30 PLATED	NPC-2436	3	18	1D06
				14	1C03	26107-080502	BOLT M 8X 50 PLATED	NPC-2436	3	19	1D06
				16	1C03	26107-080702	BOLT M 8X 70 PLATED	NPC-2436	10	19	1D16
24101-062064	BALL BEARING	NPC-2436	6	7	1D09	26107-080802	BOLT M 8X 80 PLATED	NPC-2436	3	20	1D06
24101-063024	BALL BEARING	NPC-2436	5	8	1D08	26107-080852	BOLT 8X85, COLLAR HD.	NPC-2436	14	23	1E05
24101-063034	BALL BEARING	NPC-2436	4	10	1D07	26116-080402	BOLT M 8X 40 PLATED	NPC-2436	1	4	1D03
				5	9	26116-080452	BOLT M 8X 45 PLATED	NPC-2436	3	21	1D06
24101-063044	BALL BEARING	NPC-2436	5	13	1D08	26116-101302	BOLT M10X130 PLATED	NPC-2436	10	20	1D16
24163-205265	COLLAR 20X25X26.5	NPC-2436	4	11	1D07	26116-101502	BOLT M10X150 PLATED	NPC-2436	10	21	1D16
24190-070001	BALL 7/32	NPC-2436	5	10	1D08	26116-120602	BOLT M12X 60 PLATED	NPC-2436	13	4	1E04
24190-100001	BALL 5/16, STEEL	NPC-2436	6	8	1D09	26116-121002	BOLT M12X100 PLATED	NPC-2436	13	12	1E04
				7	10	26117-040088	BOLT M 4X 8 PLATED	NPC-2437	7	26	1B09
				17	1D10				8	17	1B10
24311-000100	O-RING 1A P-10.0	NPC-2436	8	10	1D11			NPC-2438	8	22	1C11
24311-000180	O-RING 1A P-18.0	NPC-2437	1	20	1B03				9	17	1C12
		NPC-2438	1	23	1C03	26117-040257	BOLT M 4X 25	NPC-2437	8	23	1B10
24421-173208	SEAL TC17.32 08, OIL	NPC-2436	4	12	1D07					23-	1 1B10
24421-203508	SEAL TC20 35 08, OIL	NPC-2436	4	13	1D07			NPC-2438	9	26	1C12
25122-004201	V-BELT SP.A-42H	NPC-2436	1	12	1D03	26117-040357	BOLT M 4X 35	NPC-2437	8	23A	1B10
26013-080164	BOLT M 8X 16	NPC-2436	14	17	1E05	26117-060142	BOLT M 6X 14 PLATED	NPC-2436	7	11	1D10
26013-080202	BOLT W/WASHER M8X20	NPC-2436	1	13	1D03	26117-120252	BOLT M12X 25 PLATED	NPC-2436	13	5	1E04
				2	4	26117-121302	BOLT M12X130 PLATED	NPC-2436	19	9	1E11
26016-060122	BOLT M 6X 12	NPC-2436	12	34	1E02	26206-100452	BOLT M10X45	NPC-2436	1	4-	1 1D03
26016-060124	BOLT 6X12 W/L.W.	NPC-2436	2	5	1D04	26216-080182	STUD M 8X 18 PLATED	NPC-2437	2	15	1B04
26016-080124	BOLT M 8X 12	NPC-2436	14	18	1E05			NPC-2438	2	18	1C04
26018-080164	BOLT M 8X 16	NPC-2436	14	19	1E05	26347-060002	U-NUT 6	NPC-2437	8	26	1B10
26106-060082	BOLT M 6X 8 PLATED	NPC-2437	6	26	1B08			NPC-2438	9	29	1C12
				9	37	26366-060002	NUT M 6	NPC-2437	8	30	1B10
		NPC-2438	6	19	1C08			NPC-2438	9	34-	2 1C12
				7	27	26366-080002	NUT M 8	NPC-2437	4	21	1B06
				28	1C10			NPC-2438	4	16	1C06
26106-060102	BOLT M 6X 10 PLATED	NPC-2437	6	26-	1 1B08	26367-060002	NUT M 6	NPC-2437	9	30	1B11
		NPC-2438	7	27-	1 1C10			NPC-2438	9	34-	1 1C12
26106-060122	BOLT M 6X 12 PLATED	NPC-2438	6	20	1C08	26367-080002	U-NUT M 8	NPC-2436	3	22	1D06
26106-060202	BOLT M 6X 20 PLATED	NPC-2437	2	18	1B04				8	11	1D11
26106-060252	BOLT M 6X 25 PLATED	NPC-2438	9	34	1C12				10	22	1D16
26106-060352	BOLT M 6X 35 PLATED	NPC-2437	2	19	1B04				20	6	1D14
		NPC-2438	2	21	1C04					20	1D14
26106-080122	BOLT M 8X 12 PLATED	NPC-2437	4	20	1B06					29	1D14
		NPC-2438	4	15	1C06	26476-060142	BOLT M 6X 14, TAPPING	NPC-2436	7	12	1D10
26106-080302	BOLT M 8X 30 PLATED	NPC-2438	1	24	1C03					18	1D10
26107-060122	BOLT M 6X 12 PLATED	NPC-2436	3	15	1D06				8	12	1D11

PART NO.	DESCRIPTION	CATALOG NO.	GRP. NO.	REF. NO.	LOC. NO.	PART NO.	DESCRIPTION	CATALOG NO.	GRP. NO.	REF. NO.	LOC. NO.
26476-060142	BOLT M 6X 14,TAPPING	NPC-2437	8	33	1B10	760790-21700	CRANKSHAFT ASSY	NPC-2438	5	13	1C07
			9	15	1B11	760790-22500	RING SET, PISTON	NPC-2438	5	23	1C07
				16	1B11	760790-22501	RING SET, PISTON	NPC-2438	5	23- 1	1C07
				17	1B11	760790-23700	ROD ASSY, CONNECTING	NPC-2438	5	29	1C07
				41	1B12	760792-01501	COVER, CRANKCASE	NPC-2438	1	12	1C03
		NPC-2438	6	4	1C08	760792-55701	TANK ASSY, FUEL	NPC-2438	7	2- 1	1C10
				5	1C08	760792-55703	TANK,FUEL(WHITE)(14)	NPC-2438	7	2- 2	1C10
				6	1C08	760792-55720	TANK,FUEL(WHITE:14)	NPC-2438	7	2	1C10
				31	1C08						
				31-	1 1C08						
26476-060252	BOLT M 6X 25,TAPPING	NPC-2437	9	37	1C12						
			1	22	1B03						
			6	27	1B08						
			9	38	1B12						
		NPC-2438	6	32	1C08						
				33	1C08						
			7	29	1C10						
26476-060302	BOLT M 6X 30,TAPPING	NPC-2437	9	10	1B11						
26657-060002	CAP NUT M 6	NPC-2437	4	11	1B06						
		NPC-2438	4	10	1C06						
26717-080002	NUT M 8	NPC-2436	1	5	1D03						
			3	23	1D06						
26717-100002	NUT M10	NPC-2436	1	5-	1 1D03						
			14	24	1E05						
26717-120002	NUT M12	NPC-2436	19	10	1E11						
26737-160002	NUT M16	NPC-2438	5	20	1C07						
26757-060002	LOCK NUT M 6 PLATED	NPC-2437	8	27	1B10						
		NPC-2438	9	30	1C12						
26757-120002	LOCK NUT M12 PLATED	NPC-2436	13	6	1E04						
28110-100120	WRENCH 10X12	NPC-2436	18	4	1E10						
28110-140170	WRENCH 14X17	NPC-2436	18	5	1E10						
29610-000650	CLAMP, SPEED 065	NPC-2437	9	7	1B11						
29610-000950	CLAMP, SPEED 095	NPC-2437	9	8	1B11						
		NPC-2438	6	34	1C08						
7A2039-51000	BRACKET PLAS.	NPC-2436	10	1	1D16						
7A2039-62000	COVER,BELT PLAS.	NPC-2436	14	3-	1 1E05						
7A2049-32110	FENDER R PLAS.	NPC-2436	9	2	1D13						
7A2049-51000	BRACKET PLAS.	NPC-2436	10	2	1D16						
7A2049-51100	HNDL.FRAME PLAS.	NPC-2436	10	3	1D16						
7C6220-52840	SD.CLUTCH LEVER L AS	NPC-2436	12	5	1E02						
7C6220-52910	SD.CLUTCH LEVER R AS	NPC-2436	12	17	1E02						
7E4133-99290	JUG ASSY, OIL	NPC-2436	19	6	1E11						
7S0070-15000	UNIVIR SAL HITCH	NPC-2436	19	11	1E11						
760690-01500	COVER ASSY, SIDE	NPC-2437	1	10	1B03						
760690-21702	CRANKSHAFT COMP	NPC-2437	5	14	1B07						
760690-23700	ROD ASSY, CONNECTING	NPC-2437	5	28	1B07						
760692-55720	TANK,FUEL(CREAM)(21)	NPC-2437	6	2-	1 1B08						
760692-55721	TANK,FUEL(WHITE)(14)	NPC-2437	6	2-	2 1B08						
760692-55722	TANK,FUEL(WHITE)(14)	NPC-2437	6	2-	3 1B08						
760698-01560	BLOCK ASSY, CYLINDER	NPC-2437	1	1	1B03						
760698-22500	RING SET, PISTON	NPC-2437	5	22	1B07						
760698-22501	RING SET	NPC-2437	5	22-	1 1B07						
760698-55700	TANK ASSY, FUEL OIL	NPC-2437	6	2	1B08						
760790-01560	BLOCK ASSY, CYLINDER	NPC-2438	1	1	1C03						

TOTAL (ITEM= 636) (REF.= 818)

- 8 FEB. 2000

Tel: 06-6376-6348

1-32, Chayamachi, Kita-ku, OSAKA 530-8321, JAPAN

YANMAR AGRICULTURAL EQUIPMENT CO., LTD.



WWW.PlanDeGraissage.ORG